



Chipsmall Limited consists of a professional team with an average of over 10 year of expertise in the distribution of electronic components. Based in Hongkong, we have already established firm and mutual-benefit business relationships with customers from,Europe,America and south Asia,supplying obsolete and hard-to-find components to meet their specific needs.

With the principle of “Quality Parts,Customers Priority,Honest Operation,and Considerate Service”,our business mainly focus on the distribution of electronic components. Line cards we deal with include Microchip,ALPS,ROHM,Xilinx,Pulse,ON,Everlight and Freescale. Main products comprise IC,Modules,Potentiometer,IC Socket,Relay,Connector.Our parts cover such applications as commercial,industrial, and automotives areas.

We are looking forward to setting up business relationship with you and hope to provide you with the best service and solution. Let us make a better world for our industry!



## Contact us

Tel: +86-755-8981 8866 Fax: +86-755-8427 6832

Email & Skype: info@chipsmall.com Web: www.chipsmall.com

Address: A1208, Overseas Decoration Building, #122 Zhenhua RD., Futian, Shenzhen, China



Structure	Silicon Monolithic Integrated Circuit
Product series	PWM Driver for combi drive
Type	<b>BD7790KVT</b>
Function	<ul style="list-style-type: none"> <li>• 3-phase-sensor-less system, therefore don't need three hall sensors for spindle motor driver.</li> <li>• Stability high-speed start from the state of the stop for spindle motor driver.</li> </ul>

○Absolute maximum ratings

Parameter	Symbol	Limits	Unit
Power MOS supply voltage	PVcc	6	V
Control circuit power supply voltage	Vcc	6	V
Maximum driver output current	IoMAX	3 #1	A
Power dissipation	Pd	1.37 #2	W
Operating temperature range	Topr	-30~85	°C
Storage temperature range	Tstg	-55~150	°C
Joint part temperature	Tjmax	150	°C

#1 The current is guaranteed 3.0A in case of the current is turned on/off in a duty-ratio of less than 1/10 with a maximum on-time of 5ms and when short brake.

#2 PCB (70mm × 70mm × 1.6mm, occupied copper foil is less than 3%, glass epoxy standard board) mounting. Reduce power by 11.0mW for each degree above 25°C.

○Recommended operating conditions(Ta=-30~+85°C)

[Set the power supply voltage taking allowable dissipation into considering]

Parameter	Symbol	MIN	TYP	MAX	Unit
Power MOS supply voltage	PVcc	4.0	5.0	5.5	V
Control circuit power supply voltage	Vcc	4.0	5.0	5.5	V

This product isn't designed for protection against radioactive rays.

○ Electrical characteristics

(Unless otherwise noted Ta=25°C, Vcc=PVcc=5V, Vref=1.25V, RL(CT,STP,LOAD)=8Ω+47μH, RL(SP)=2Ω+47μH, RNF=0.2Ω, CTL1,2=3.3V, GVSW=0V, VIN1,2,3,4,5,6=OPEN, VCOM=OPEN, VCCOM=OPEN, VCOUT=OPEN)

Parameter		Symbol	MIN.	TYP.	MAX.	Unit	Condition
Circuit current	Quiescent current	ICC	—	8	20	mA	CTL1,2=H
	Current in standby mode	IST	—	—	0.2	mA	CTL1,2=L
Actuator driver block	Input dead zone (one side)	VDZACT1,2,3	—	—	3	mV	
	Output offset voltage	VOO1,2,3	-50	—	50	mV	
	Voltage gain (CH1,2,3)	GVC1,2,3	15.5	17.5	19.5	dB	External input resistor 10kΩ
	Output On resistor (top and bottom)	RON1,2,3	—	1.2	1.8	Ω	Io=500mA
	PWM frequency	f1,2,3CH	215	310	405	kHz	
Stepping driver block	Input dead zone (one side)	VDZ4,5	10	30	50	mV	
	Output offset voltage	VOO4,5	-50	—	50	mV	
	Voltage gain	GVC4,5	15.5	17.5	19.5	dB	
	Output On resistor (top and bottom)	RON4,5	—	1.6	2.4	Ω	Io=500mA
	PWM frequency	f4,5CH	215	310	405	kHz	
Loading driver block	Input dead zone (one side)	VDZ6	20	60	100	mV	CTL1=H, CTL2=L
	Output offset voltage	VOO6	-50	—	50	mV	CTL1=H, CTL2=L
	Voltage gain	GVC6	15.5	17.5	19.5	dB	CTL1=H, CTL2=L
	Output On resistor (top and bottom)	RON6	—	1.8	2.7	Ω	Io=500mA, CTL1=H, CTL2=L
	PWM frequency	f6CH	215	310	405	kHz	CTL1=H, CTL2=L
Spindle driver block	Input dead zone of gm1 (one side)	VDZSP1	2	30	100	mV	
	Input dead zone of gm2 (one side)	VDZSP2	6	90	300	mV	GVSW=M
	Input dead zone of gm3 (one side)	VDZSP3	10	150	500	mV	GVSW=H
	Input output gain 1	gm1	0.88	1.1	1.32	A/V	
	Input output gain 2	gm2	0.28	0.36	0.44	A/V	GVSW=M
	Input output gain 3	gm3	0.17	0.22	0.27	A/V	GVSW=H
	Output On resistor (top and bottom)	RONSP	—	0.6	1.4	Ω	Io=500mA
	Output limit voltage	VLIMSP	0.18	0.22	0.26	V	
Others	PWM frequency	fSP	—	167	—	kHz	
	Vref drop mute ON threshold voltage	VMVref	—	0.7	1.0	V	
	Vcc drop mute ON threshold voltage	VMVccD	3.2	3.6	4.0	V	
	CTL1 L voltage	VCTL1L	0	—	1.0	V	
	CTL1 H voltage	VCTL1H	2.0	—	3.3	V	
	CTL2, GVSW L voltage	VCTL2L, VGVL	0	—	1.0	V	
	CTL2, GVSW M(Hi-z) voltage	VCTL2M, VGVM	1.6	—	2.0	V	OPEN (Hi-z) is also available.
CTL2, GVSW H voltage	VCTL2H, VG VH	2.6	—	3.3	V		

GVSW	L	M (Hi-z)	H
Gain mode	gm1	gm2	gm3

CTL1	CTL2	Brake mode	SPINDLE Output	CH1,2,3 Output	CH4,5 Output	CH6 Output
L	L	—	Hi-Z	Hi-Z	Hi-Z	Hi-Z
	M	Short brake	ACTIVE	Hi-Z	Hi-Z	Hi-Z
	H		ACTIVE	ACTIVE	ACTIVE	ACTIVE
H	L	Reverse brake	Hi-Z	Hi-Z	ACTIVE	ACTIVE
	M (Hi-z)		ACTIVE	Hi-Z	Hi-Z	Hi-Z
	H		ACTIVE	ACTIVE	ACTIVE	Hi-Z

Please supply the middle level voltage for CTL2 when using it in the mode of CTL1=L and CTL2=M.

○ Package outlines

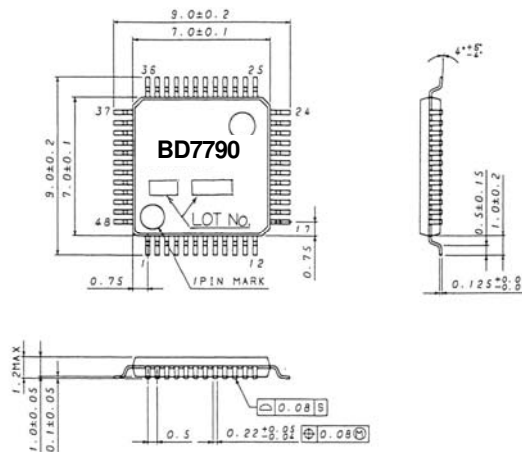

(UNIT : mm)

OBLOCK diagram / Application circuit

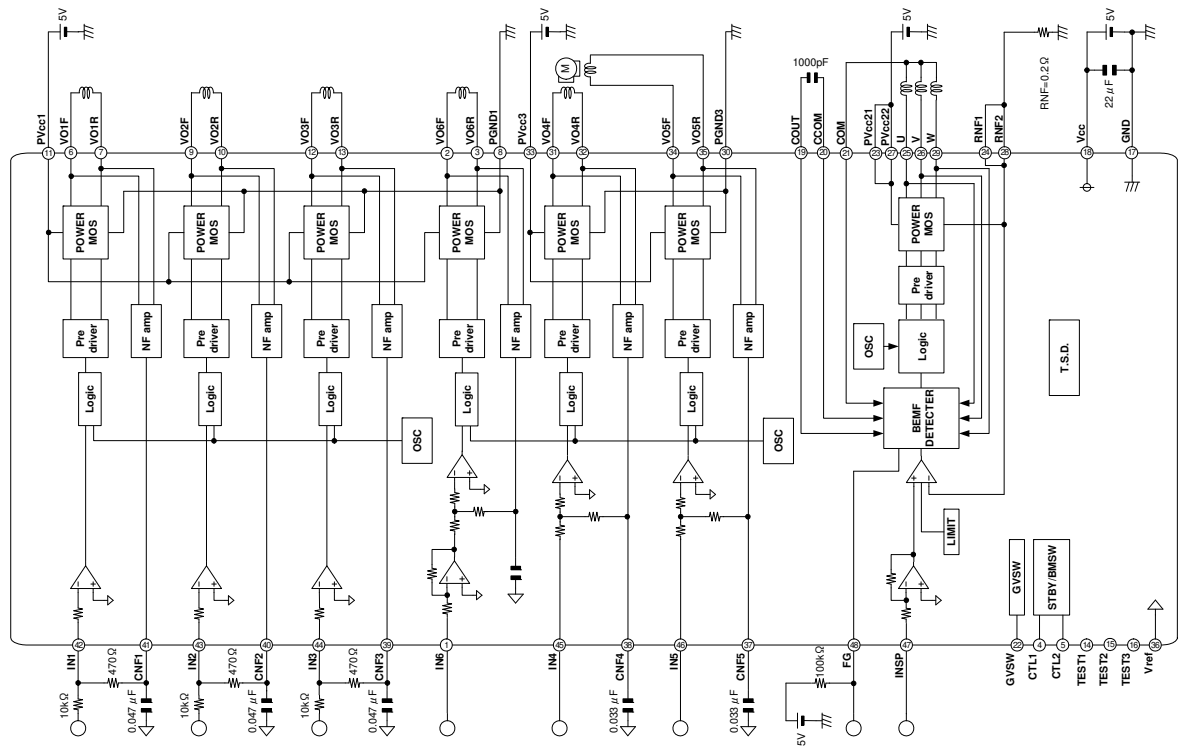

◎ PIN DESCRIPTION

Pin No.	Symbol	Description	Pin No.	Symbol	Description
1	IN6	PWM Driver (CH6) input	25	U	Spindle driver output U
2	VO6F	PWM Driver(CH6) positive output	26	V	Spindle driver output V
3	VO6R	PWM Driver(CH6) negative output	27	PVcc22	Spindle driver power supply22
4	CTL1	Driver logic control input1	28	RNF2	Spindle driver current sense output2
5	CTL2	Driver logic control input2	29	W	Spindle driver output W
6	VO1F	PWM Driver(CH1) positive output	30	PGND3	PWM driver power ground3
7	VO1R	PWM Driver(CH1) negative output	31	VO4F	PWM Driver(CH4) positive output
8	PGND1	PWM driver power ground1	32	VO4R	PWM Driver(CH4) negative output
9	VO2F	PWM Driver(CH2) positive output	33	PVcc3	PWM driver power supply3
10	VO2R	PWM Driver(CH2) negative output	34	VO5F	PWM Driver(CH5) positive output
11	PVcc1	PWM driver power supply1	35	VO5R	PWM Driver(CH5) negative output
12	VO3F	PWM Driver(CH3) positive output	36	Vref	Reference voltage input
13	VO3R	PWM Driver(CH3) negative output	37	CNF5	PWM driver (CH5) feedback filter
14	TEST1	Test terminal1	38	CNF4	PWM driver (CH4) feedback filter
15	TEST2	Test terminal2	39	CNF3	PWM driver (CH3) feedback filter
16	TEST3	Test terminal3	40	CNF2	PWM driver (CH2) feedback filter
17	GND	Pre unit ground	41	CNF1	PWM driver (CH1) feedback filter
18	Vcc	Pre unit power supply	42	IN1	PWM driver (CH1) input
19	COUT	Smoothing capacitor connection terminal(Output side)	43	IN2	PWM driver (CH2) input
20	CCOM	Smoothing capacitor connection terminal(COM side)	44	IN3	PWM driver (CH3) input
21	COM	Motor coil center point input terminal	45	IN4	PWM driver (CH4) input
22	GVSU	Control for gain of spindle	46	IN5	PWM driver (CH5) input
23	PVcc21	Spindle driver power supply21	47	INSP	Spindle driver input
24	RNF1	Spindle driver current sense output1	48	FG	Frequency generator output

Positive/Negative of the output terminals are determined in reference to those of the input terminals.

## ●Cautions on use

1. Absolute maximum ratings  
This IC might be destroyed when the absolute maximum ratings, such as impressed voltage (PVcc, Vcc) or the operating temperature range (Topr), is exceeded, and whether the destruction is short circuit mode or open circuit mode cannot be specified. Please take into consideration the physical countermeasures for safety, such as fusing, if a particular mode that exceeds the absolute maximum rating is assumed.
2. Reverse polarity connection  
Connecting the power line to the IC in reverse polarity (from that recommended) will damage the part. Please utilize the direction protection device as a diode in the supply line.
3. GND line  
The ground line is where the lowest potential and transient voltages are connected to the IC.
4. Thermal design  
Do not exceed the power dissipation (Pd) of the package specification rating under actual operation, and please design enough temperature margins.
5. Short circuit mode between terminals and wrong mounting  
Do not mount the IC in the wrong direction and be careful about the reverse-connection of the power connector. Moreover, this IC might be destroyed when the dust short the terminals between them or GND.
6. Radiation  
Strong electromagnetic radiation can cause operation failures.
7. ASO (Area of Safety Operation)  
When using the IC, set the output transistor so that it does not exceed absolute maximum ratings or ASO.
8. TSD (Thermal Shut-Down)  
The TSD is activated when the junction temperature (Tj) reaches 175°C (with +/-25°C hysteresis), and the output terminal is switched to Hi-z. The TSD circuit designed to shut the IC off to prevent runaway thermal operation. It is not designed to protect or guarantee its operation. Do not continue to use the IC after operating this circuit.
9. Vcc, GND and RNF wiring layout  
Vcc, GND and RNF layout should be as wide as possible and at minimum distance. Wire to ground to prevent Vcc-PVcc and GND-PGND-GND side of RNF resistor from having common impedance. Connect a capacitor between Vcc and GND to stabilize.
10. Regarding input pin of the IC  
This monolithic IC contains P+ isolation and P substrate layers between adjacent elements to keep them isolated. PN junctions are formed at the intersection of these P layers with the N layers of other elements, creating a parasitic diode or transistor. For example, the relation between each potential is as follows:

When GND > Pin A and GND > Pin B, the PN junction operates as a parasitic diode.

When Pin B > GND > Pin A, the PN junction operates as a parasitic transistor.

Parasitic diodes can occur inevitably in the structure of the IC. The operation of parasitic diodes can result in mutual interference among circuits, operational faults, or physical damage. Accordingly, methods by which parasitic diodes operate, such as applying a voltage that is lower than the GND (P substrate) voltage to an input pin, should not be used.

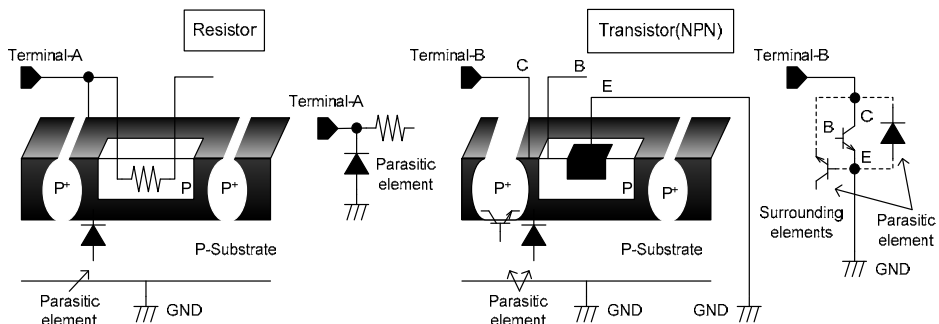

Simplified structure of IC

11. Capacitor between Vcc and GND  
This IC has steep change of the voltage and current because of PWM driver. Therefore, the capacitor controls Vcc voltage by attaching a capacitor between Vcc and GND. Wiring impedance decreases the capacitors capabilities if the capacitor is far from the IC. Therefore, a capacitor should be placed between Vcc and GND, close to the IC.
12. Supply fault, ground fault and short-circuit between output terminals  
Do not short-circuit between any output terminal and supply terminal (supply fault) or ground (ground fault), or between any output terminals (load short-circuit). When mounting the IC on the circuit board, be extremely cautious about the orientation of the IC. If the orientation is mistaken, the IC may break down and produce smoke in some cases.
13. Inspection by the set circuit board  
When testing the IC on an application board, connecting a capacitor to a pin with low impedance subjects the IC to stress. Always discharge capacitors after each process or step. Always turn the IC's power supply off before connecting it to, or removing it from a jig or fixture, during the inspection process. Ground the IC during assembly steps as an antistatic measure. Use similar precaution when transporting and storing the IC.
14. Reverse-rotation braking  
High-speed rotation may cause reverse-rotation braking. Monitor the voltage applied to the output terminal and consider the revolutions applied to the reversed-rotation brake.
15. Application circuit  
It is one sample that explains standard operation and usage of this IC about the described example of the application circuit and information on the constant etc. Therefore, please be sure to consult with our sales representative in advance before mass production design, when a circuit different from application circuit is composed of external.

## Notes

No copying or reproduction of this document, in part or in whole, is permitted without the consent of ROHM Co.,Ltd.

The content specified herein is subject to change for improvement without notice.

The content specified herein is for the purpose of introducing ROHM's products (hereinafter "Products"). If you wish to use any such Product, please be sure to refer to the specifications, which can be obtained from ROHM upon request.

Examples of application circuits, circuit constants and any other information contained herein illustrate the standard usage and operations of the Products. The peripheral conditions must be taken into account when designing circuits for mass production.

Great care was taken in ensuring the accuracy of the information specified in this document. However, should you incur any damage arising from any inaccuracy or misprint of such information, ROHM shall bear no responsibility for such damage.

The technical information specified herein is intended only to show the typical functions of and examples of application circuits for the Products. ROHM does not grant you, explicitly or implicitly, any license to use or exercise intellectual property or other rights held by ROHM and other parties. ROHM shall bear no responsibility whatsoever for any dispute arising from the use of such technical information.

The Products specified in this document are intended to be used with general-use electronic equipment or devices (such as audio visual equipment, office-automation equipment, communication devices, electronic appliances and amusement devices).

The Products specified in this document are not designed to be radiation tolerant.

While ROHM always makes efforts to enhance the quality and reliability of its Products, a Product may fail or malfunction for a variety of reasons.

Please be sure to implement in your equipment using the Products safety measures to guard against the possibility of physical injury, fire or any other damage caused in the event of the failure of any Product, such as derating, redundancy, fire control and fail-safe designs. ROHM shall bear no responsibility whatsoever for your use of any Product outside of the prescribed scope or not in accordance with the instruction manual.

The Products are not designed or manufactured to be used with any equipment, device or system which requires an extremely high level of reliability the failure or malfunction of which may result in a direct threat to human life or create a risk of human injury (such as a medical instrument, transportation equipment, aerospace machinery, nuclear-reactor controller, fuel-controller or other safety device). ROHM shall bear no responsibility in any way for use of any of the Products for the above special purposes. If a Product is intended to be used for any such special purpose, please contact a ROHM sales representative before purchasing.

If you intend to export or ship overseas any Product or technology specified herein that may be controlled under the Foreign Exchange and the Foreign Trade Law, you will be required to obtain a license or permit under the Law.



Thank you for your accessing to ROHM product informations.  
More detail product informations and catalogs are available, please contact us.

### ROHM Customer Support System

<http://www.rohm.com/contact/>