



Chipsmall Limited consists of a professional team with an average of over 10 year of expertise in the distribution of electronic components. Based in Hongkong, we have already established firm and mutual-benefit business relationships with customers from,Europe,America and south Asia,supplying obsolete and hard-to-find components to meet their specific needs.

With the principle of "Quality Parts,Customers Priority,Honest Operation,and Considerate Service",our business mainly focus on the distribution of electronic components. Line cards we deal with include Microchip,ALPS,ROHM,Xilinx,Pulse,ON,Everlight and Freescale. Main products comprise IC,Modules,Potentiometer,IC Socket,Relay,Connector.Our parts cover such applications as commercial,industrial, and automotives areas.

We are looking forward to setting up business relationship with you and hope to provide you with the best service and solution. Let us make a better world for our industry!



Contact us

Tel: +86-755-8981 8866 Fax: +86-755-8427 6832

Email & Skype: info@chipsmall.com Web: www.chipsmall.com

Address: A1208, Overseas Decoration Building, #122 Zhenhua RD., Futian, Shenzhen, China



COMPLEMENTARY SILICON POWER TRANSISTORS

- STMicroelectronics PREFERRED SALESTYPES

DESCRIPTION

The BD909 and BD911 are silicon Epitaxial-Base NPN power transistors mounted in Jedec TO-220 plastic package. They are intended for use in power linear and switching applications.

The complementary PNP types are BD910 and BD912 respectively.

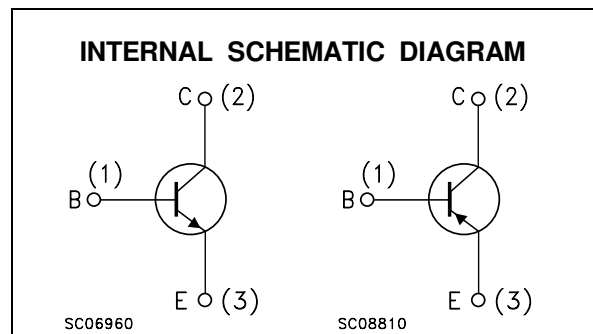
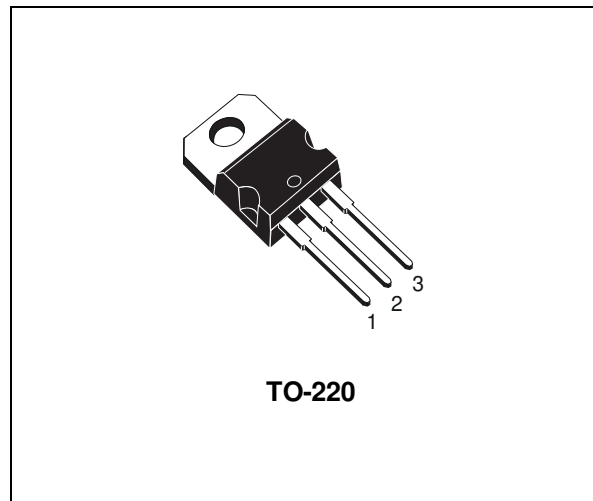

ABSOLUTE MAXIMUM RATINGS

| Symbol | Parameter | Value | | Unit | |
|------------|--|-------|------------|------|------------------|
| | | NPN | BD909 | | BD911 |
| | | PNP | BD910 | | BD912 |
| V_{CBO} | Collector-Base Voltage ($I_E = 0$) | | 80 | 100 | V |
| V_{CEO} | Collector-Emitter Voltage ($I_B = 0$) | | 80 | 100 | V |
| V_{EBO} | Emitter-Base Voltage ($I_C = 0$) | | 5 | | V |
| I_E, I_C | Collector Current | | 15 | | A |
| I_B | Base Current | | 5 | | A |
| P_{tot} | Total Dissipation at $T_c \leq 25^\circ\text{C}$ | | 90 | | W |
| T_{stg} | Storage Temperature | | -65 to 150 | | $^\circ\text{C}$ |
| T_j | Max. Operating Junction Temperature | | 150 | | $^\circ\text{C}$ |

For PNP types voltage and current values are negative.

BD909 / BD910 / BD911 / BD912

THERMAL DATA

| | | | | |
|-----------------------|----------------------------------|-----|-----|------|
| R _{thj-case} | Thermal Resistance Junction-case | Max | 1.4 | °C/W |
|-----------------------|----------------------------------|-----|-----|------|

ELECTRICAL CHARACTERISTICS (T_{case} = 25 °C unless otherwise specified)

| Symbol | Parameter | Test Conditions | Min. | Typ. | Max. | Unit |
|------------------------|---|--|---------------|------|----------------------|----------------------|
| I _{CBO} | Collector Cut-off Current (I _E = 0) | for BD909/910 V _{CB} = 80 V for BD911/912 V _{CB} = 100 V T _{case} = 150 °C for BD909/910 V _{CB} = 80 V for BD911/912 V _{CB} = 100 V | | | 500 500 5 5 | μA μA mA mA |
| I _{CEO} | Collector Cut-off Current (I _B = 0) | for BD909/910 V _{CE} = 40 V for BD911/912 V _{CE} = 50 V | | | 1 1 | mA mA |
| I _{EBO} | Emitter Cut-off Current (I _C = 0) | V _{EB} = 5 V | | | 1 | mA |
| V _{CEO(sus)*} | Collector-Emitter Sustaining Voltage (I _B = 0) | I _C = 100 mA for BD909/910 for BD911/912 | 80 100 | | | V V |
| V _{CE(sat)*} | Collector-Emitter Saturation Voltage | I _C = 5 A I _B = 0.5 A I _C = 10 A I _B = 2.5 A | | | 1 3 | V V |
| V _{BE(sat)*} | Base-Emitter Saturation Voltage | I _C = 10 A I _B = 2.5 A | | | 2.5 | V |
| V _{BE*} | Base-Emitter Voltage | I _C = 5 A V _{CE} = 4 V | | | 1.5 | V |
| h _{FE*} | DC Current Gain | I _C = 0.5 A V _{CE} = 4 V I _C = 5 A V _{CE} = 4 V I _C = 10 A V _{CE} = 4 V | 40 15 5 | | 250 150 | |
| f _T | Transition frequency | I _C = 0.5 A V _{CE} = 4 V | 3 | | | MHz |

* Pulsed: Pulse duration = 300 μs, duty cycle 1.5 %
For PNP types voltage and current values are negative.

Safe Operating Area

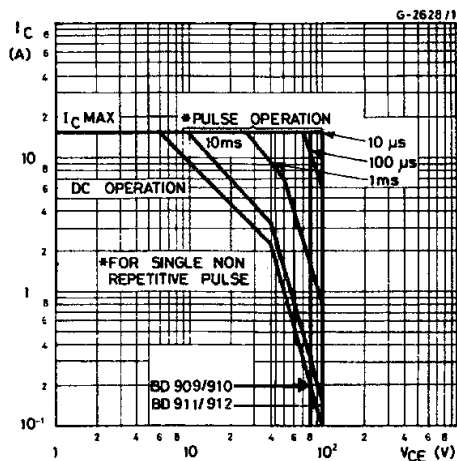

Derating Curves

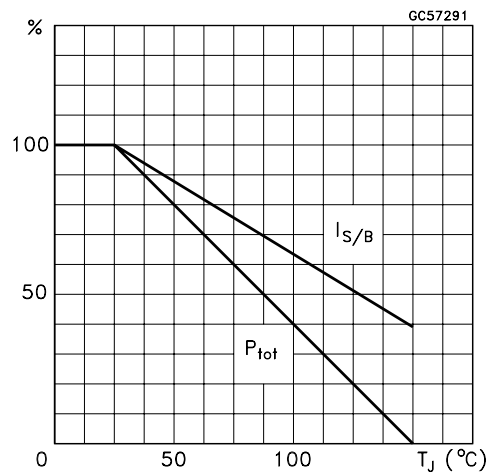

DC Current Gain (NPN type)

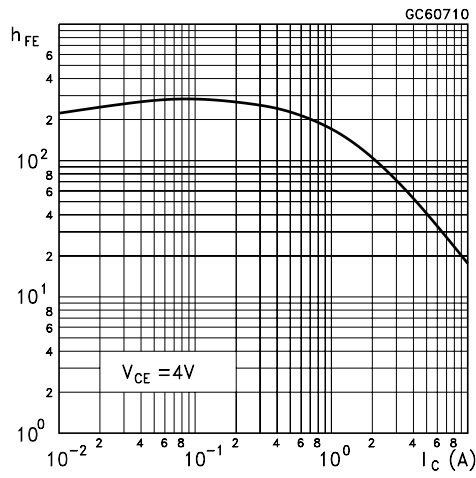

DC Current Gain (PNP type)

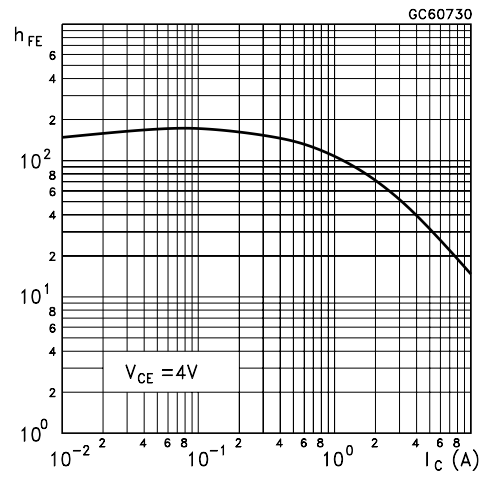

DC Transconductance (NPN type)

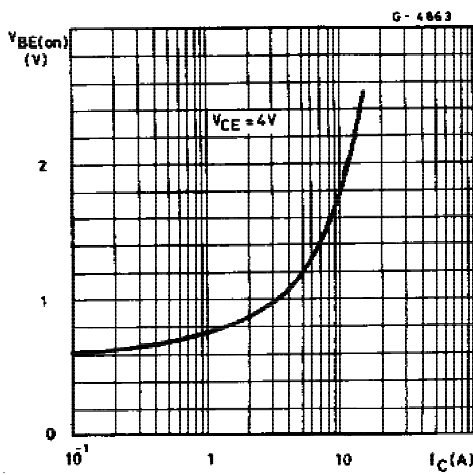

DC Transconductance (PNP type)

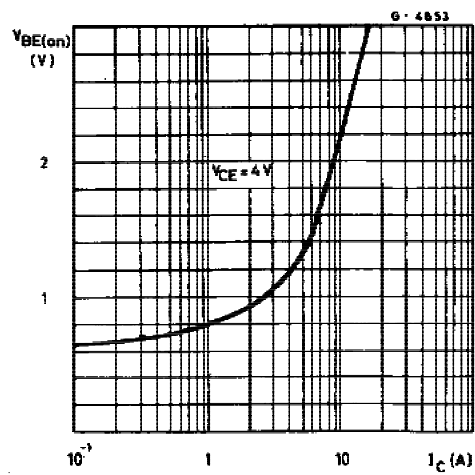

Collector-Emitter Saturation Voltage (NPN type)

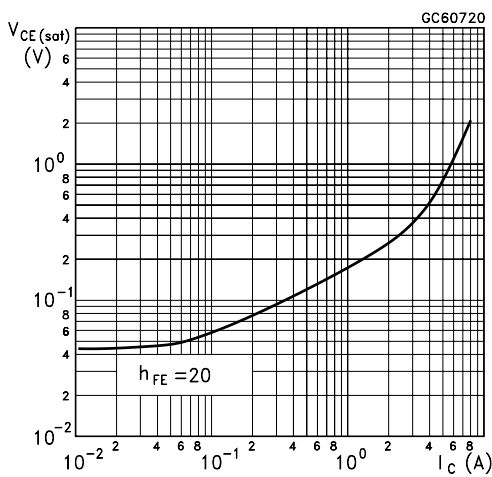

Collector-Emitter Saturation Voltage (PNP type)

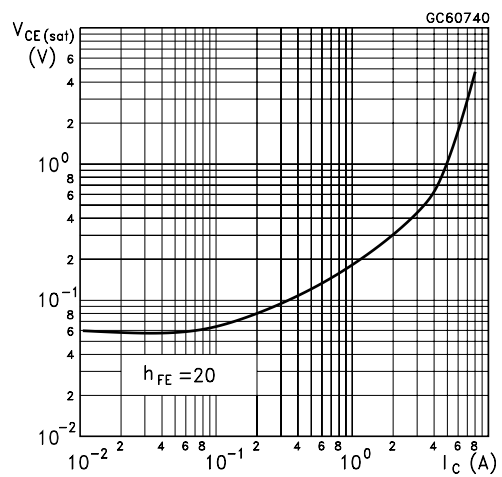

Base-Emitter Saturation Voltage (NPN type)

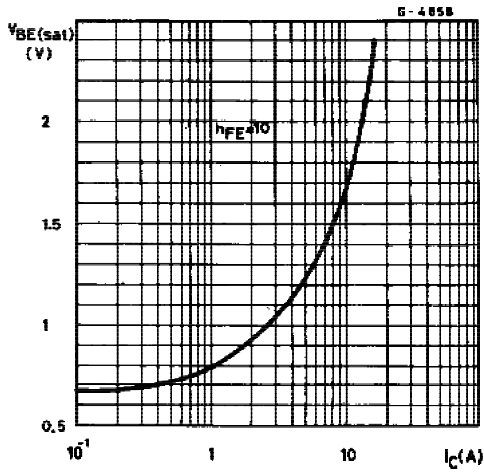

Base-Emitter Saturation Voltage (PNP type)

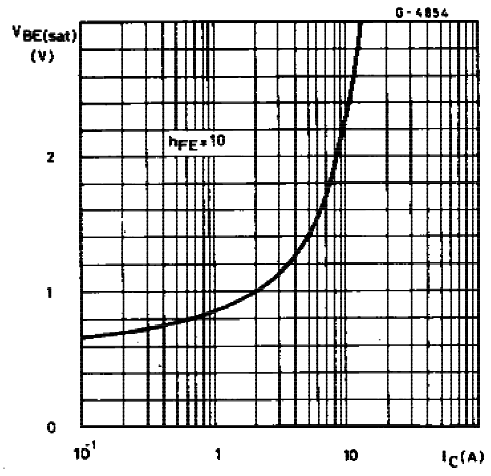

Transition Frequency (NPN type)

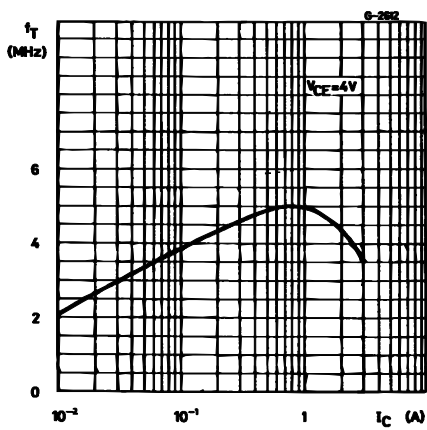

Transition Frequency (PNP type)

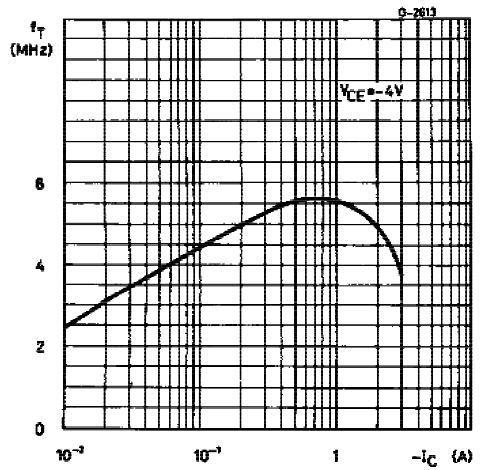

TO-220 MECHANICAL DATA

| DIM. | mm | | | inch | | |
|------|-------|------|-------|-------|-------|-------|
| | MIN. | TYP. | MAX. | MIN. | TYP. | MAX. |
| A | 4.40 | | 4.60 | 0.173 | | 0.181 |
| C | 1.23 | | 1.32 | 0.048 | | 0.051 |
| D | 2.40 | | 2.72 | 0.094 | | 0.107 |
| D1 | | 1.27 | | | 0.050 | |
| E | 0.49 | | 0.70 | 0.019 | | 0.027 |
| F | 0.61 | | 0.88 | 0.024 | | 0.034 |
| F1 | 1.14 | | 1.70 | 0.044 | | 0.067 |
| F2 | 1.14 | | 1.70 | 0.044 | | 0.067 |
| G | 4.95 | | 5.15 | 0.194 | | 0.203 |
| G1 | 2.4 | | 2.7 | 0.094 | | 0.106 |
| H2 | 10.0 | | 10.40 | 0.393 | | 0.409 |
| L2 | | 16.4 | | | 0.645 | |
| L4 | 13.0 | | 14.0 | 0.511 | | 0.551 |
| L5 | 2.65 | | 2.95 | 0.104 | | 0.116 |
| L6 | 15.25 | | 15.75 | 0.600 | | 0.620 |
| L7 | 6.2 | | 6.6 | 0.244 | | 0.260 |
| L9 | 3.5 | | 3.93 | 0.137 | | 0.154 |
| DIA. | 3.75 | | 3.85 | 0.147 | | 0.151 |

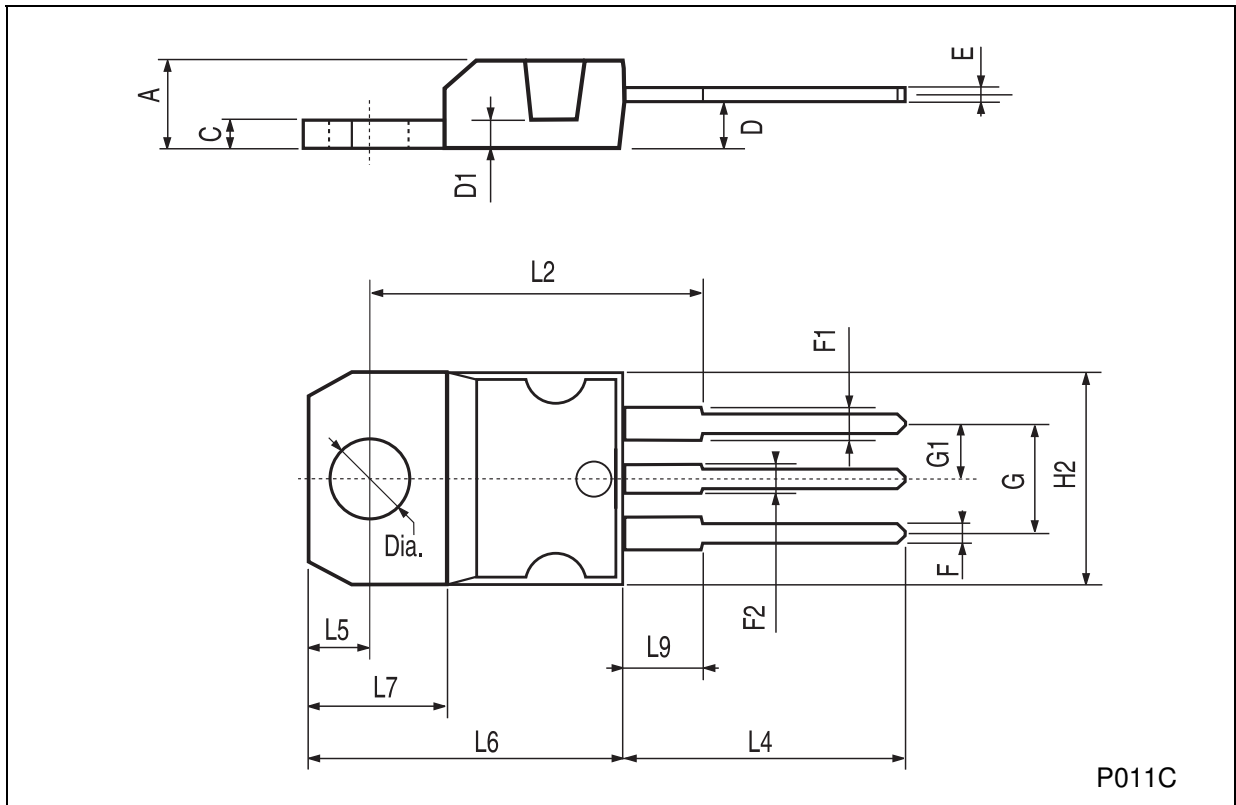

Information furnished is believed to be accurate and reliable. However, STMicroelectronics assumes no responsibility for the consequences of use of such information nor for any infringement of patents or other rights of third parties which may result from its use. No license is granted by implication or otherwise under any patent or patent rights of STMicroelectronics. Specification mentioned in this publication are subject to change without notice. This publication supersedes and replaces all information previously supplied. STMicroelectronics products are not authorized for use as critical components in life support devices or systems without express written approval of STMicroelectronics.

The ST logo is a trademark of STMicroelectronics

© 1999 STMicroelectronics – Printed in Italy – All Rights Reserved

STMicroelectronics GROUP OF COMPANIES

Australia - Brazil - China - Finland - France - Germany - Hong Kong - India - Italy - Japan - Malaysia - Malta - Morocco -
Singapore - Spain - Sweden - Switzerland - United Kingdom - U.S.A.

<http://www.st.com>