



Chipsmall Limited consists of a professional team with an average of over 10 year of expertise in the distribution of electronic components. Based in Hongkong, we have already established firm and mutual-benefit business relationships with customers from,Europe,America and south Asia,supplying obsolete and hard-to-find components to meet their specific needs.

With the principle of “Quality Parts,Customers Priority,Honest Operation,and Considerate Service”,our business mainly focus on the distribution of electronic components. Line cards we deal with include Microchip,ALPS,ROHM,Xilinx,Pulse,ON,Everlight and Freescale. Main products comprise IC,Modules,Potentiometer,IC Socket,Relay,Connector.Our parts cover such applications as commercial,industrial, and automotives areas.

We are looking forward to setting up business relationship with you and hope to provide you with the best service and solution. Let us make a better world for our industry!



Contact us

Tel: +86-755-8981 8866 Fax: +86-755-8427 6832

Email & Skype: info@chipsmall.com Web: www.chipsmall.com

Address: A1208, Overseas Decoration Building, #122 Zhenhua RD., Futian, Shenzhen, China



Single-chip Type with Built-in FET Switching Regulators

Simple Step-down Switching Regulators with Built-in Power MOSFET



BD9325FJ, BD9326EFJ, BD9327EFJ

No.10027ECT06

●Description

The BD9325FJ, BD9326EFJ and BD9327EFJ are step-down regulators that integrate a low resistance high side N-channel MOSFET. It achieves 2A / 3A / 4A continuous output current over a wide input supply range. Current mode operation provides fast transient response and easy phase compensation.

●Features

- 1) Wide operating INPUT Range 4.75V~18.0V
- 2) Selectable 2A / 3A / 4A Output Current
- 3) Selectable 0.16Ω / 0.12Ω / 0.11Ω Internal MOSFET Switch
- 4) Low ESR Output Ceramic Capacitors are Available
- 5) Low Standby Current during Shutdown Mode
- 6) 380kHz Operating Frequency
- 7) Feedback voltage 0.9V ±1.5% Accuracy at room temp. (±3.0% for -40°C to 85°C temperature range)
- 8) Protection circuit: UnderVoltage lockout protection circuit
Thermal shutdown circuit
OverCurrent protection circuit
- 9) SOP-J8 Package for 2A model, HTSOP-J8 Package for 3A, 4A models (with Exposed thermal PAD)

●Applications

Distributed Power System
Pre-Regulator for Linear Regulator

●Line up matrix

LINE-UP	BD9325FJ	BD9326EFJ	BD9327EFJ
FET ON-RESISTANCE	0.16 Ω	0.12 Ω	0.11 Ω
OUTPUT CURRENT	2.0 A	3.0A	4.0 A
Package	SOP-J8	HTSOP-J8	HTSOP-J8

● **Absolute maximum ratings** (Ta = 25°C)

Parameter	Symbol	Ratings	Unit
Supply Voltage	VIN	20	V
Switch Voltage	Vsw	20	V
Power Dissipation for HTSOP-J8	Pd1	3760 ^{*1}	mW
Power Dissipation for SOP-J8	Pd2	675 ^{*2}	mW
Operating Temperature Range	Topr	-40~+85	°C
Storage Temperature Range	Tstg	-55~+150	°C
Junction Temperature	Tjmax	150	°C
BST Voltage	VBST	Vsw+7	V
EN Voltage	VEN	20	V
All other pins	VOTH	7	V

*1 Derating is done 30.08 mW/°C for operating above Ta ≥ 25°C (Mount on 4-layer 70.0mm × 70.0mm × 1.6mm board)

*2 Derating is done 5.4 mW/°C for operating above Ta ≥ 25°C (Mount on 1-layer 70.0mm × 70.0mm × 1.6mm board)

● **Operation Range** (Ta = -40~85°C)

Parameter	Symbol	Ratings			Unit
		Min	Typ	Max	
Supply Voltage	VIN	4.75	12	18	V
SW Voltage	Vsw	-0.5	-	18	V
Output current for BD9325FJ	ISW2	-	-	2**	A
Output current for BD9326EFJ	ISW3	-	-	3**	A
Output current for BD9327EFJ	ISW4	-	-	4**	A

** Pd, ASO should not be exceeded

● **Electrical characteristics** (Unless otherwise specified VIN=12V Ta=25°C)

Parameter	Symbol	Limits			Unit	Conditions
		Min	Typ	Max		
Error amplifier block						
FB input bias current	IFB	-	0.1	2	μA	
Feedback voltage1	VFB1	0.886	0.900	0.914	V	Voltage follower
Feedback voltage2	VFB2	0.873	0.900	0.927	V	Ta=-40°C~85°C
SW block – SW						
Hi-side FET On-resistance for BD9325FJ	RON2	-	0.16	-	Ω	ISW = -0.8A ***
Hi-side FET On-resistance for BD9326EFJ	RON3	-	0.12	-	Ω	ISW = -0.8A ***
Hi-side FET On-resistance for BD9327EFJ	RON4	-	0.11	-	Ω	ISW = -0.8A ***
Lo-side FET On-resistance	RONL	-	10	-	Ω	ISW = 0.1A
Leak current N-channel	ILEAKN	-	0	10	μA	VIN = 18V, Vsw = 0V
Switch Current Limit for BD9325FJ	ILIMIT2	2.5	-	-	A	***
Switch Current Limit for BD9326EFJ	ILIMIT3	3.5	-	-	A	***
Switch Current Limit for BD9327EFJ	ILIMIT4	4.5	-	-	A	***
Maximum duty cycle	MDUTY	-	90	-	%	VFB = 0V
General						
Enable Sink current	IEN	86	181	275	μA	VEN = 12V
Enable Threshold voltage	VEN	1.1	1.18	1.4	V	
Under Voltage Lockout threshold	VUVLO	4.05	4.40	4.75	V	VIN rising
Under Voltage Lockout Hysteresis	VHYS	-	0.1	-	V	
Soft Start Current	ISS	23	41	62	μA	Vss = 0 V
Soft Start Time	TSS	-	1.6	-	ms	CSS = 0.1 μF
Operating Frequency	FOSC	300	380	460	kHz	
Circuit Current	ICC	-	2.1	4.3	mA	VFB = 1.5V, VEN = 12V
Quiescent Current	IQUI	-	80	170	μA	VEN = 0V

*** See the series line-up table below.

●Block diagram

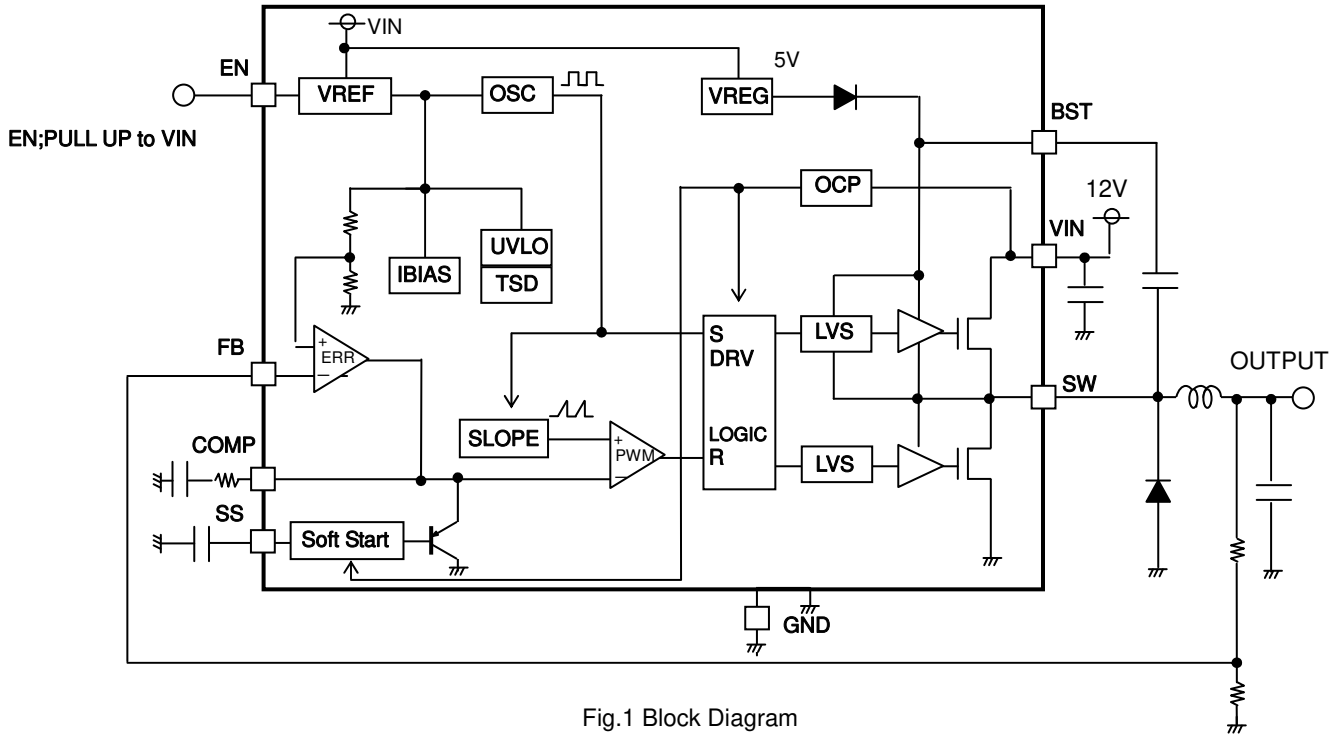

Fig.1 Block Diagram

●Typical application circuit

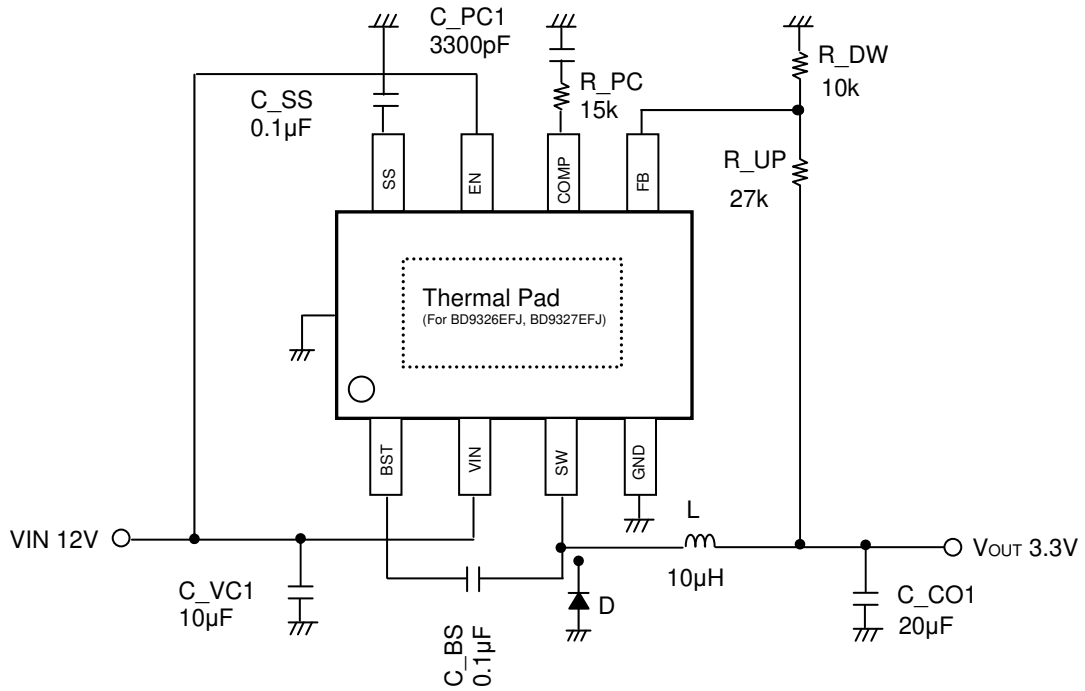

Fig.2 Application Circuit

●Block operation

- VREG
A block to generate constant-voltage for DC/DC boosting.
- VREF
A block that generates internal reference voltage of 2.9 V (Typ.).
- TSD/UVLO
TSD (Thermal shutdown)/UVLO (Under Voltage Lockout) protection block. The TSD circuit shuts down IC at 175°C (Typ.)
The UVLO circuit shuts down the IC when the VCC is Low Voltage.
- Error amp block (ERR)
This is the circuit to compare the reference voltage and the feedback voltage of output voltage. The COMP pin voltage resulting from this comparison determines the switching duty. At the time of startup, since the soft start is operated by the SS pin voltage, the COMP pin voltage is limited to the SS pin voltage.
- Oscillator block (OSC)
This block generates the oscillating frequency.
- SLOPE block
This block generates the triangular waveform from the clock created by OSC. Generated triangular waveform is sent to the PWM comparator.
- PWM block
The COMP pin voltage output by the error amp is compared to the SLOPE block's triangular waveform to determine the switching duty. Since the switching duty is limited by the maximum duty ratio which is determined internally, it does not become 100%.
- DRV block
A DC/DC driver block. A signal from the PWM is input to drive the power FETs.
- Soft start circuit
Since the output voltage rises gradually while restricting the current at the time of startup, it is possible to prevent the output voltage overshoot or the rush current.

●Pin assignment and pin function

Pin No.	Pin name	Function
1	BST	High-Side Gate Drive Boost Input
2	VIN	Power Input
3	SW	Power Switching Output
4	GND	Ground
5	FB	Feed Back Input
6	COMP	Compensation Node
7	EN	Enable Input
8	SS	Soft Start Control Input

● Typical performance characteristics (Unless otherwise specified, $V_{IN}=12V$ $T_a = 25^\circ C$)

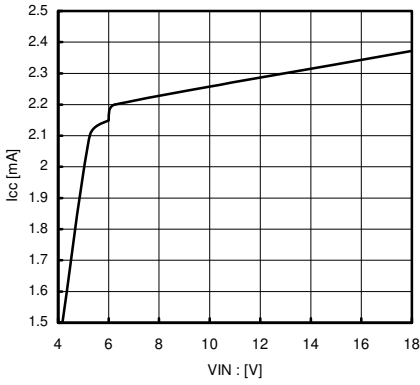

Fig.3 Circuit Current (No switching)

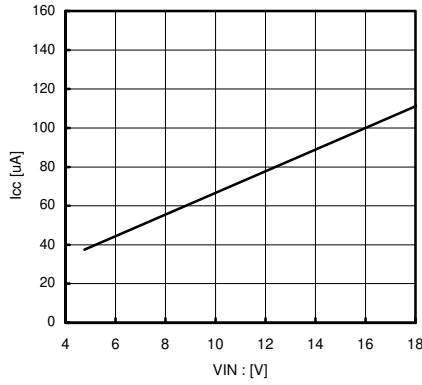

Fig.4 Quiescent Current (IC not active)

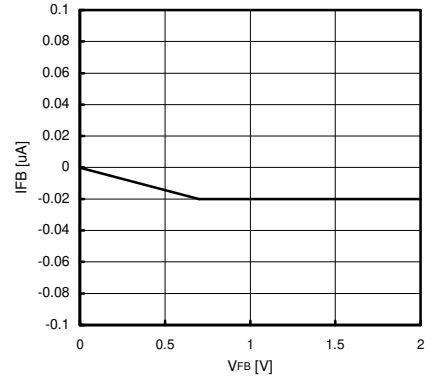

Fig.5 Input Bias Current

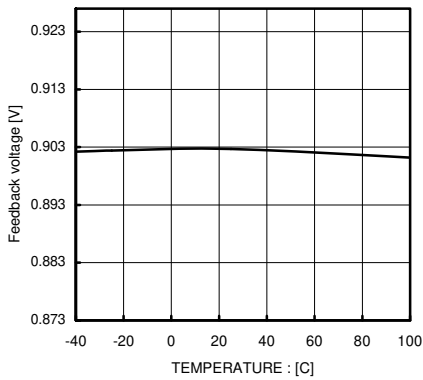

Fig.6 Feedback voltage

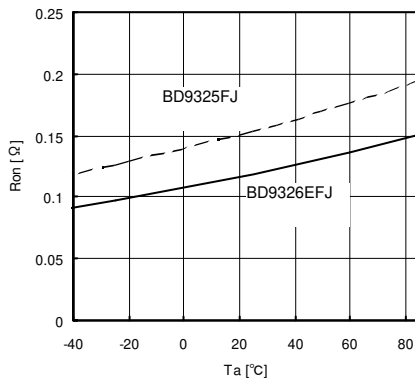

Fig.7 Hi-Side On-resistance

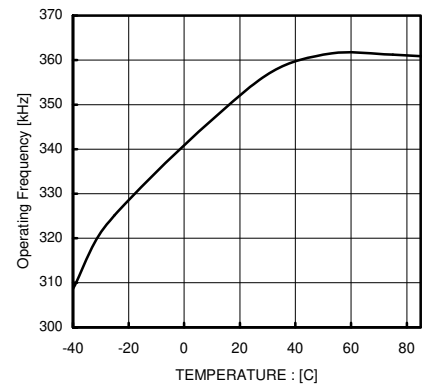

Fig.8 Operating Frequency

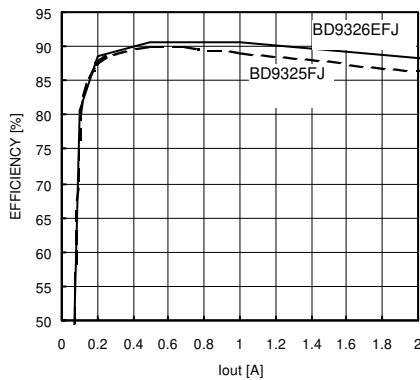

Fig.9 STEP Down Efficiency ($V_{IN}=12V$ $V_{OUT}=3.3V$ $L=10\mu H$)

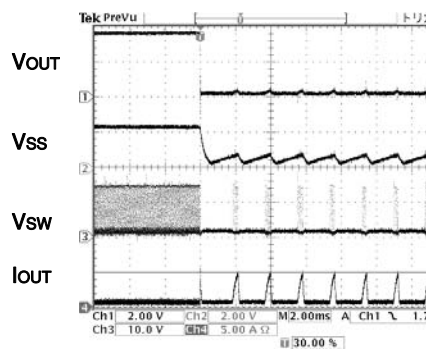

Fig.10 OverCurrent Protection (V_{OUT} is shorted to GND)

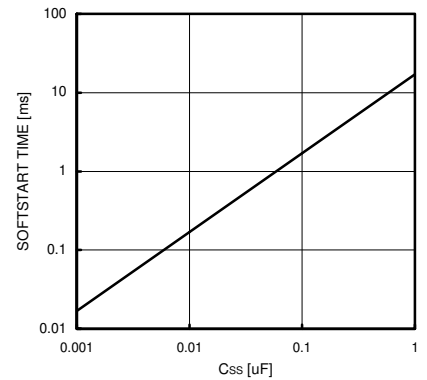

Fig.11 Soft Start Time

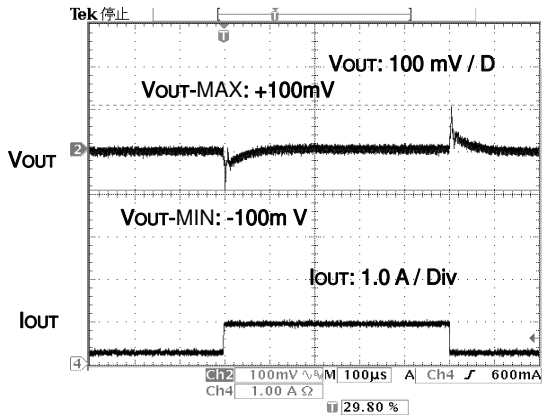

Fig.12 Transient Response
(VIN= 12V VOUT= 3.3V L= 10µH Cout =22µF Iout= 0.2-1.0A)

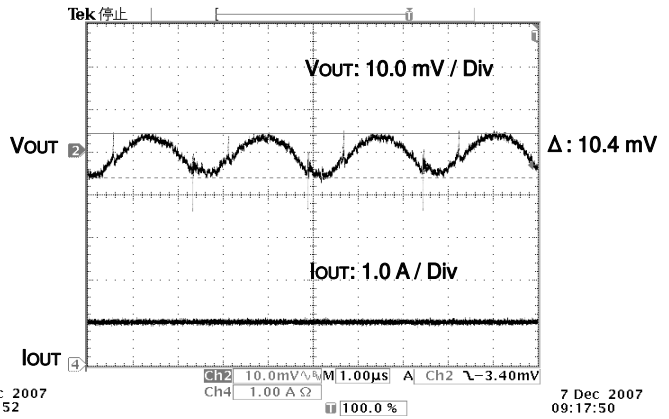

Fig.13 Output Ripple Voltage
(VIN= 12V VOUT= 3.3V L= 10µH Cout =22µF Iout= 1.0A)

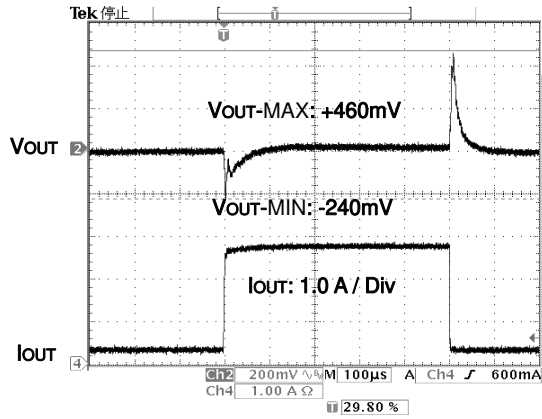

Fig.14 Transient Response
(VIN= 12V V_{out}= 3.3V L= 10µH Cout =22µF Iout= 0.2-3.0A)

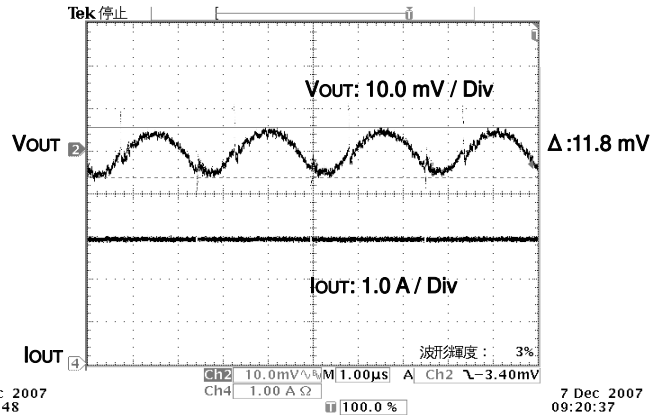

Fig.15 Output Ripple Voltage
(VIN= 12V VOUT= 3.3V L= 10µH Cout =22µF Iout= 3.0A)

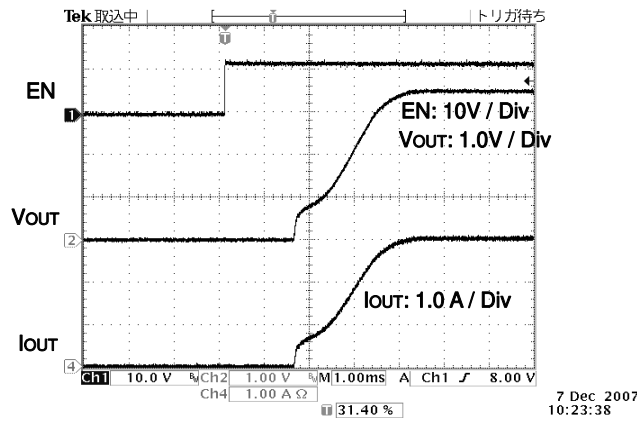

Fig.16 Start Up waveform
(VIN= 12V VOUT= 3.3V L= 22µH CSS= 0.1µF Iout= 0A)

●Selecting application components

(1) Output LC constant (Buck Converter)

The inductance L to use for output is decided by the rated current ILR and input current maximum value IOMAX of the inductance.

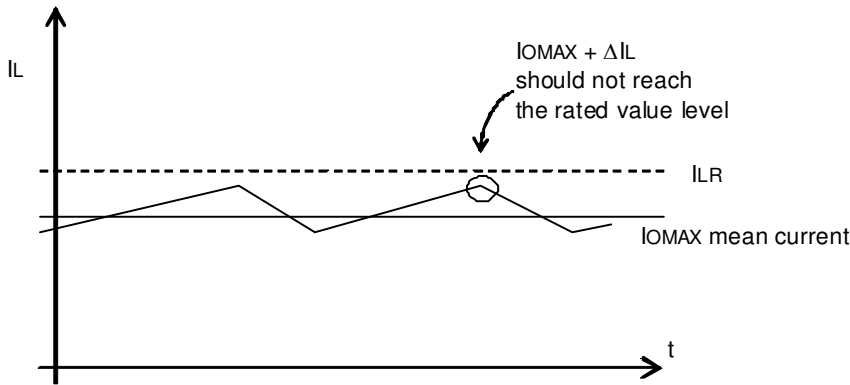

Fig.17

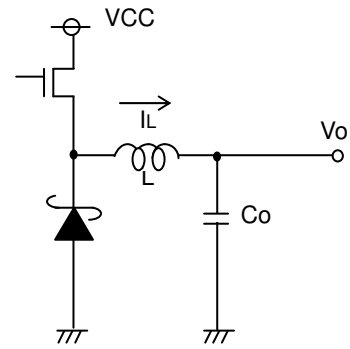

Fig.18

Adjust so that IOMAX + ΔIL does not reach the rated current value ILR. At this time, ΔIL can be obtained by the following equation.

$$\Delta IL = \frac{1}{L} \times (V_{CC} - V_o) \times \frac{V_o}{V_{CC}} \times \frac{1}{f} \text{ [A]}$$

Set with sufficient margin because the inductance L value may have the dispersion of ± 30%.

For the capacitor C to use for the output, select the capacitor which has the larger value in the ripple voltage VPP permissible value and the drop voltage permissible value at the time of sudden load change.

Output ripple voltage is decided by the following equation.

$$\Delta V_{PP} = \Delta IL \times R_{ESR} + \frac{\Delta IL}{2C_o} \times \frac{V_o}{V_{CC}} \times \frac{1}{f} \text{ [V]}$$

Perform setting so that the voltage is within the permissible ripple voltage range.

For the drop voltage VDR during sudden load change, please perform the rough calculation by the following equation.

$$V_{DR} = \frac{\Delta IL}{C_o} \times 10 \mu s \text{ [V]}$$

However, 10μs is the rough calculation value of the DC/DC response speed. Make Co settings so that these two values will be within the limit values.

(2) Loop Compensation

Choosing compensation capacitor C1 and resistor R3

The example of DC/DC converter application bode plot is shown below. The compensation resistor R3 will set the cross over frequency Fc that decides the stability and response speed of DC/DC converter. So compensation resistor R3 has to be adjusted to adequate value for good stability and response speed.

The cross over frequency Fc can be adjusted by changing the compensation resistor R3 connected to COMP terminal. The higher cross over frequency achieves good response speed, but less stability. And the lower cross over frequency shows good stability, but worse response speed.

Usually, the 1/10 of DC/DC converter operating frequency is used for cross over frequency Fc. So please decide the compensation resistor and capacitor using the following formula on setting Fc to 1/10 of operating frequency at first. After that, please measure and adjust the cross over frequency on your set (on the actual application) to meet the enough response speed and phase-margin.

(i) Choosing phase compensation resistor R3

Please decide the compensation resistor R3 on following formula.

$$\text{Compensation Resistor } R3 = 5800 \times C_{OUT} \times F_c \times V_{OUT} \quad [\Omega]$$

Where

C_{OUT} : Output capacitor connected to DC/DC output

V_{OUT} : Output voltage

F_c : Desired cross over frequency (38kHz)

(ii) Choosing phase compensation capacitor C1

The stability of DC/DC converter needs to cancel the phase delay that is from output LC filter by inserting the phase advance.

The phase advance can be added by the zero on compensation resistor and capacitor.

The LC resonant frequency FLC and the zero on compensation resistor and capacitor are expressed below.

$$\text{LC resonant frequency } F_{LC} = \frac{1}{2\pi\sqrt{LC_{OUT}}} \quad [\text{Hz}]$$

$$\text{Zero by C1 and R3 } F_Z = \frac{1}{2\pi C_1 R_3} \quad [\text{Hz}]$$

Please choose C1 to make FZ to 1 / 3 of FLC .

$$\text{Compensation Capacitor } C_1 = \frac{3}{2\pi F_{LC} R_3} \quad [\text{F}]$$

(iii) The condition of the loop compensation stability

The stability of DC/DC converter is important. To secure the operating stability, please check the loop compensation has the enough phase-margin. For the condition of loop compensation stability, the phase-delay must be less than 150 degree where Gain is 0 dB. Namely over 30 degree phase-margin is needed.

Lastly after the calculation above, please measure and adjust the phase-margin to secure over 30 degree.

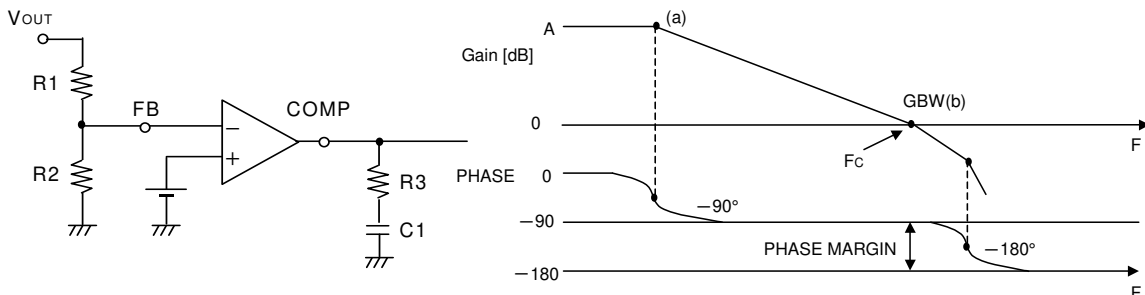

(3) Design of Feedback Resistance constant

Set the feedback resistance as shown below.

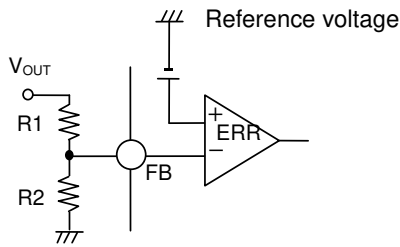

$$V_{OUT} = \frac{R1 + R2}{R2} \times \text{Reference Voltage} \quad [V]$$

● Soft Start Function

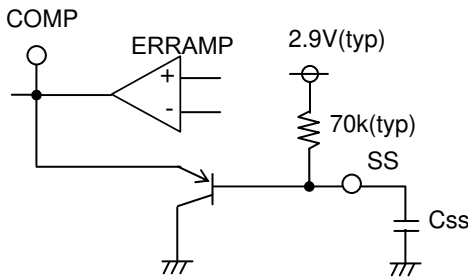

The buck converter has an adjustable Soft Start function to prevent high inrush current during start up. The soft-start time is set by the external capacitor connected to SS pin. The soft start time is given by;

$$T_{ss} [ms] = 16.2 \cdot C [\mu F]$$

Please confirm the overshoot of the output voltage and inrush current when deciding the SS capacitor value.

● EN Function

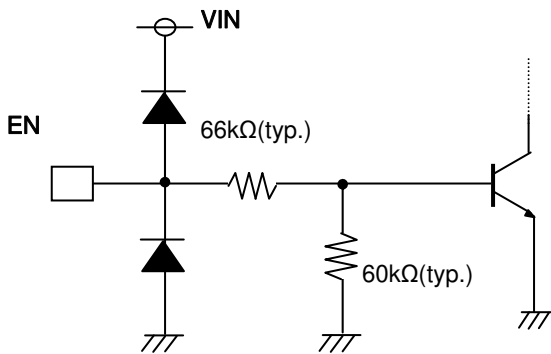

Fig.19 The equivalent internal circuit.

The EN terminal controls IC's shut down. Leaving EN terminal open makes IC shutdown. To start the IC, EN terminal should be connected to VIN or the other power source output. When the EN voltage exceed 1.2V (typ.), the IC start operating.

●Layout Pattern Consideration

Two high pulsing current flowing loops exist in the buck regulator system.

The first loop, when FET is ON, starts from the input capacitors, to the VIN terminal, to the SW terminal, to the inductor, to the output capacitors, and then returns to the input capacitor through GND.

The second loop, when FET is OFF, starts from the shotkey diode, to the inductor, to the output capacitor, and then returns to the shotkey diode through GND.

To reduce the noise and improve the efficiency, please minimize these two loop area.

Especially input capacitor, output capacitor and shotkey diode should be connected to GND plain.

PCB Layout may affect the thermal performance, noise and efficiency greatly. So please take extra care when designing PCB Layout patterns.

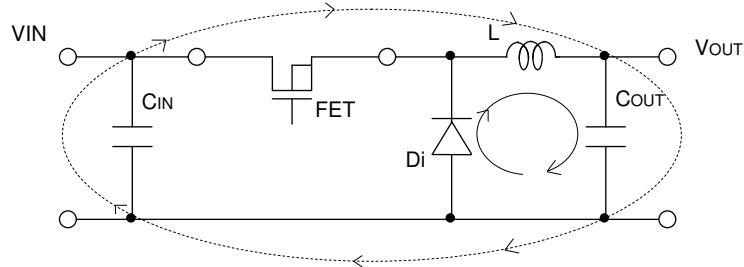

Fig.20 Current loop in Buck regulator system

- The thermal Pad on the back side of IC has the great thermal conduction to the chip. So using the GND plain as broad and wide as possible can help thermal dissipation. And a lot of thermal via for helping the spread of heat to the different layer is also effective.
- The input capacitors should be connected as close as possible to the VIN terminal.
- Keep sensitive signal traces such as trace connected FB and COMP away from SW pin.
- The inductor, the shot key diode and the output capacitors should be placed close to SW pin as much as possible.

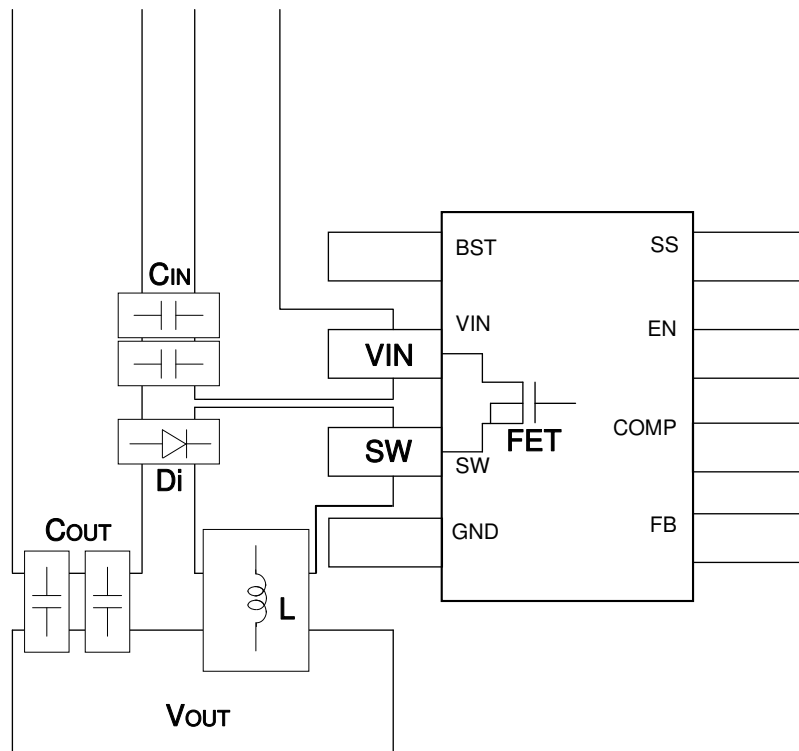

Fig.21 The example of PCB layout pattern

●Operation Notes

- 1) Absolute maximum ratings
Use of the IC in excess of absolute maximum ratings such as the applied voltage or operating temperature range may result in IC damage. Assumptions should not be made regarding the state of the IC (short mode or open mode) when such damage is suffered. A physical safety measure such as a fuse should be implemented when use of the IC in a special mode where the absolute maximum ratings may be exceeded is anticipated.
- 2) GND potential
Ensure a minimum GND pin potential in all operating conditions.
- 3) Setting of heat
Use a thermal design that allows for a sufficient margin in light of the power dissipation (Pd) in actual operating conditions.
- 4) Pin short and mistake fitting
Use caution when orienting and positioning the IC for mounting on printed circuit boards. Improper mounting may result in damage to the IC. Shorts between output pins or between output pins and the power supply and GND pins caused by the presence of a foreign object may result in damage to the IC.
- 5) Actions in strong magnetic field
Use caution when using the IC in the presence of a strong magnetic field as doing so may cause the IC to malfunction.
- 6) Testing on application boards
When testing the IC on an application board, connecting a capacitor to a pin with low impedance subjects the IC to stress. Always discharge capacitors after each process or step. Ground the IC during assembly steps as an antistatic measure, and use similar caution when transporting or storing the IC. Always turn the IC's power supply off before connecting it to or removing it from a jig or fixture during the inspection process.
- 7) Ground wiring patterns
When using both small signal and large current GND patterns, it is recommended to isolate the two ground patterns, placing a single ground point at the application's reference point so that the pattern wiring resistance and voltage variations caused by large currents do not cause variations in the small signal ground voltage. Be careful not to change the GND wiring patterns of any external components.
- 8) Regarding input pin of the IC
This monolithic IC contains P+ isolation and P substrate layers between adjacent elements in order to keep them isolated. P/N junctions are formed at the intersection of these P layers with the N layers of other elements to create a variety of parasitic elements.
For example, when the resistors and transistors are connected to the pins as shown in Fig.22, a parasitic diode or a transistor operates by inverting the pin voltage and GND voltage.
The formation of parasitic elements as a result of the relationships of the potentials of different pins is an inevitable result of the IC's architecture. The operation of parasitic elements can cause interference with circuit operation as well as IC malfunction and damage. For these reasons, it is necessary to use caution so that the IC is not used in a way that will trigger the operation of parasitic elements such as by the application of voltages lower than the GND (P substrate) voltage to input and output pins.

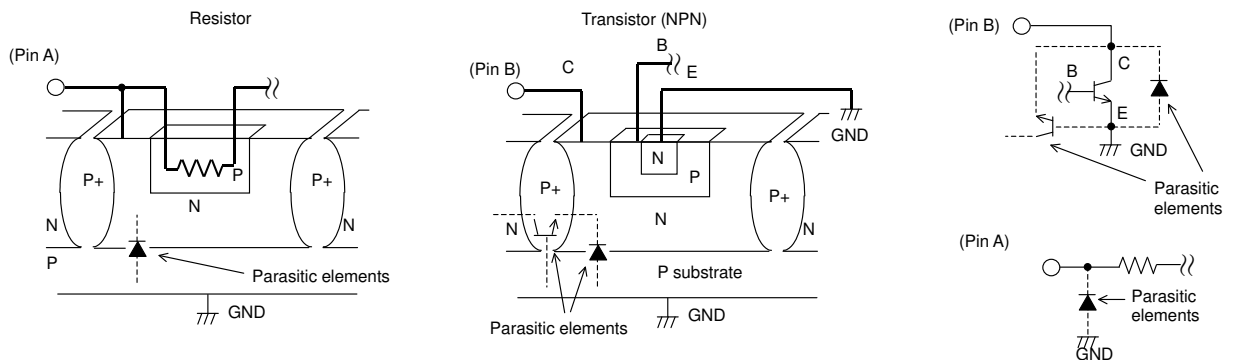

Fig.22 Example of a Simple Monolithic IC Architecture

- 9) Overcurrent protection circuits
An overcurrent protection circuit designed according to the output current is incorporated for the prevention of IC damage that may result in the event of load shorting. This protection circuit is effective in preventing damage due to sudden and unexpected accidents. However, the IC should not be used in applications characterized by the continuous operation or transitioning of the protection circuits. At the time of thermal designing, keep in mind that the current capacity has negative characteristics to temperatures.

10) Thermal shutdown circuit (TSD)

This IC incorporates a built-in TSD circuit for the protection from thermal destruction. The IC should be used within the specified power dissipation range. However, in the event that the IC continues to be operated in excess of its power dissipation limits, the attendant rise in the chip's junction temperature T_j will trigger the TSD circuit to turn off all output power elements. Operation of the TSD circuit presumes that the IC's absolute maximum ratings have been exceeded. Application designs should never make use of the TSD circuit.

11) Testing on application boards

At the time of inspection of the installation boards, when the capacitor is connected to the pin with low impedance, be sure to discharge electricity per process because it may load stresses to the IC. Always turn the IC's power supply off before connecting it to or removing it from a jig or fixture during the inspection process. Ground the IC during assembly steps as an antistatic measure, and use similar caution when transporting or storing the IC.

● I/O Equivalent Circuit Diagram

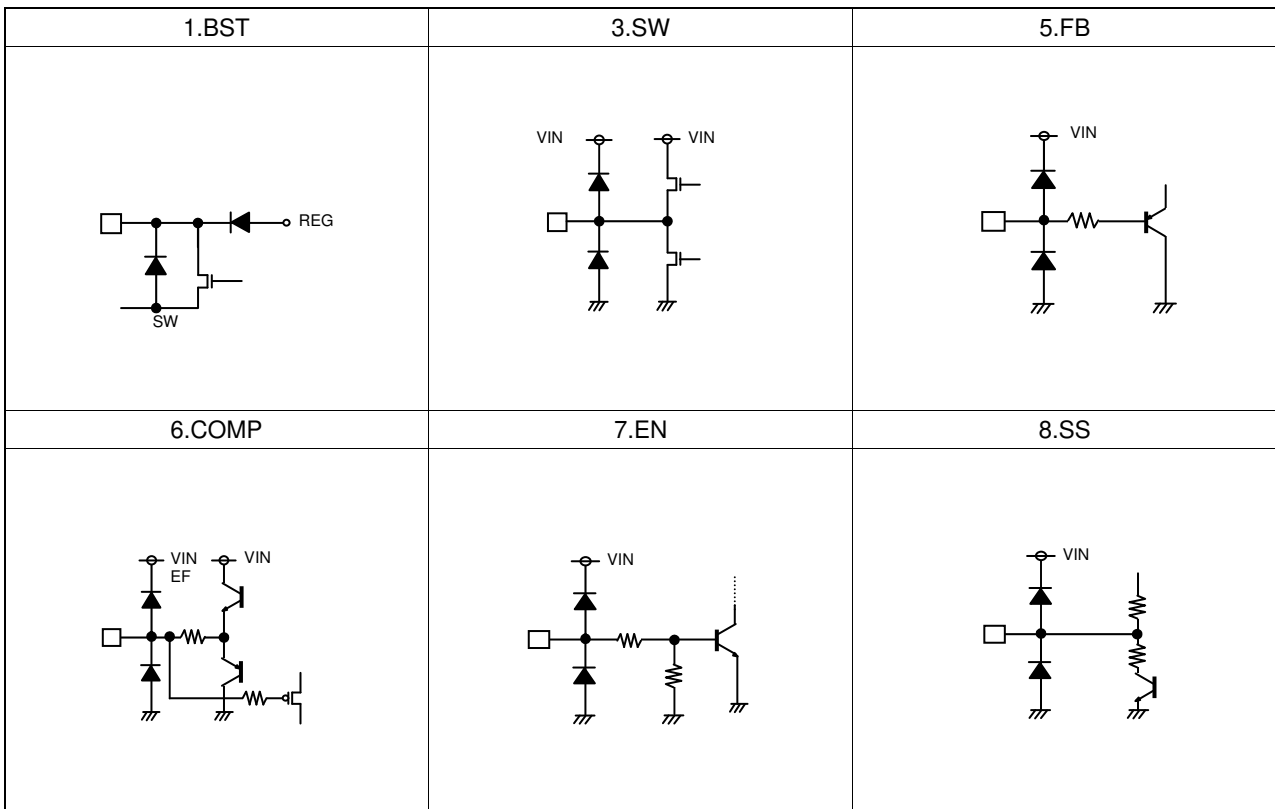

● Power Dissipation

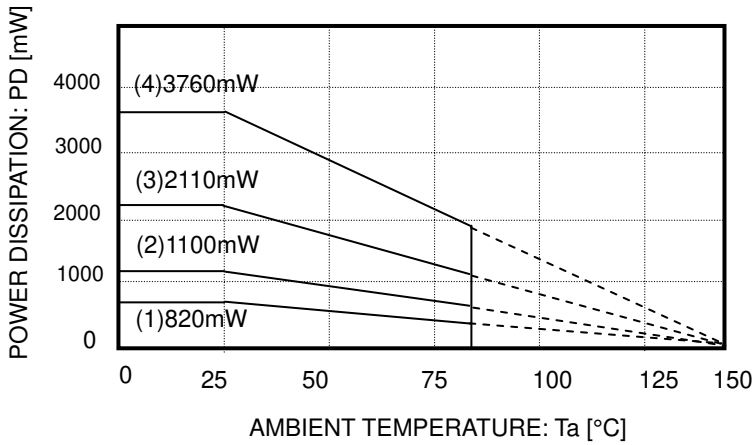

HTSOP-J8 Package

On 70 × 70 × 1.6 mm glass epoxy PCB

- (1) 1-layer board (Backside copper foil area 0 mm × 0 mm)
- (2) 2-layer board (Backside copper foil area 15 mm × 15 mm)
- (3) 2-layer board (Backside copper foil area 70 mm × 70 mm)
- (4) 4-layer board (Backside copper foil area 70 mm × 70 mm)

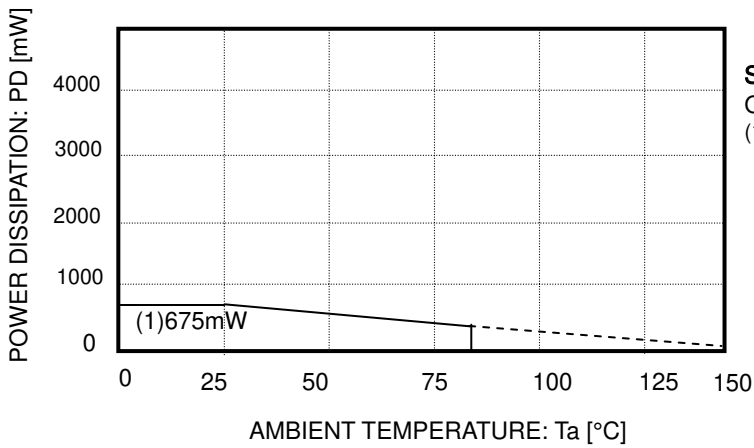

SOP-J8 Package

On 70 × 70 × 1.6 mm glass epoxy PCB

- (1) 1-layer board (Backside copper foil area 0 mm × 0 mm)

●Ordering part number

B	D
---	---

Part No.

9	3	2	5
---	---	---	---

Part No.

9325
9326
9327

F	J
---	---

Package

FJ : SOP-J8
EFJ : HTSOP-J8

E	2
---	---

Packaging and forming specification
E2: Embossed tape and reel

SOP-J8

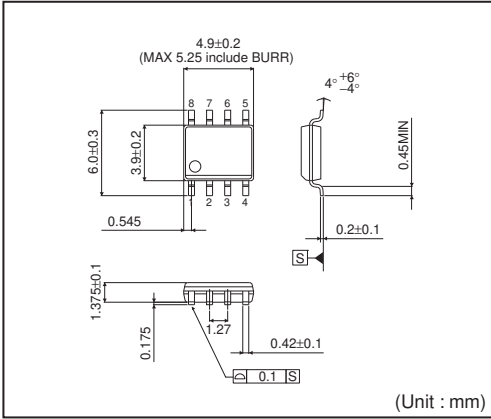

<Tape and Reel information>

Tape	Embossed carrier tape
Quantity	2500pcs
Direction of feed	E2 (The direction is the 1 pin of product is at the upper left when you hold reel on the left hand and you pull out the tape on the right hand)

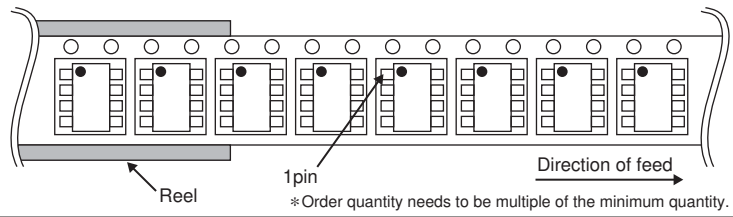

HTSOP-J8

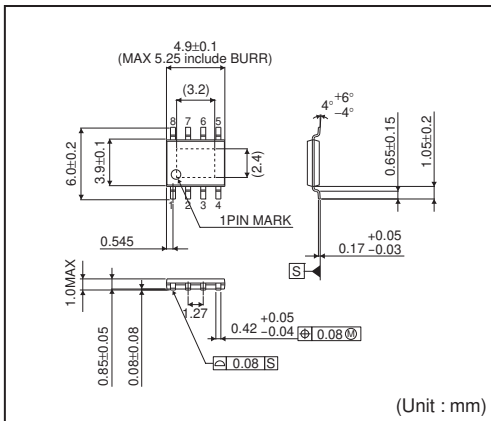

<Tape and Reel information>

Tape	Embossed carrier tape
Quantity	2500pcs
Direction of feed	E2 (The direction is the 1 pin of product is at the upper left when you hold reel on the left hand and you pull out the tape on the right hand)

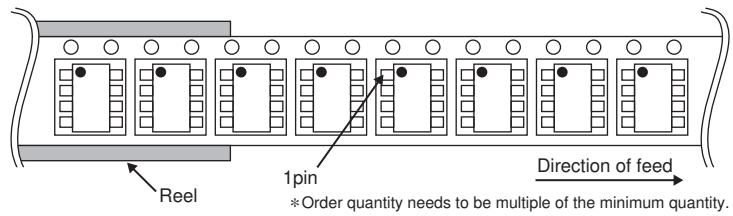

Notes

No copying or reproduction of this document, in part or in whole, is permitted without the consent of ROHM Co.,Ltd.

The content specified herein is subject to change for improvement without notice.

The content specified herein is for the purpose of introducing ROHM's products (hereinafter "Products"). If you wish to use any such Product, please be sure to refer to the specifications, which can be obtained from ROHM upon request.

Examples of application circuits, circuit constants and any other information contained herein illustrate the standard usage and operations of the Products. The peripheral conditions must be taken into account when designing circuits for mass production.

Great care was taken in ensuring the accuracy of the information specified in this document. However, should you incur any damage arising from any inaccuracy or misprint of such information, ROHM shall bear no responsibility for such damage.

The technical information specified herein is intended only to show the typical functions of and examples of application circuits for the Products. ROHM does not grant you, explicitly or implicitly, any license to use or exercise intellectual property or other rights held by ROHM and other parties. ROHM shall bear no responsibility whatsoever for any dispute arising from the use of such technical information.

The Products specified in this document are intended to be used with general-use electronic equipment or devices (such as audio visual equipment, office-automation equipment, communication devices, electronic appliances and amusement devices).

The Products specified in this document are not designed to be radiation tolerant.

While ROHM always makes efforts to enhance the quality and reliability of its Products, a Product may fail or malfunction for a variety of reasons.

Please be sure to implement in your equipment using the Products safety measures to guard against the possibility of physical injury, fire or any other damage caused in the event of the failure of any Product, such as derating, redundancy, fire control and fail-safe designs. ROHM shall bear no responsibility whatsoever for your use of any Product outside of the prescribed scope or not in accordance with the instruction manual.

The Products are not designed or manufactured to be used with any equipment, device or system which requires an extremely high level of reliability the failure or malfunction of which may result in a direct threat to human life or create a risk of human injury (such as a medical instrument, transportation equipment, aerospace machinery, nuclear-reactor controller, fuel-controller or other safety device). ROHM shall bear no responsibility in any way for use of any of the Products for the above special purposes. If a Product is intended to be used for any such special purpose, please contact a ROHM sales representative before purchasing.

If you intend to export or ship overseas any Product or technology specified herein that may be controlled under the Foreign Exchange and the Foreign Trade Law, you will be required to obtain a license or permit under the Law.



Thank you for your accessing to ROHM product informations.
More detail product informations and catalogs are available, please contact us.

ROHM Customer Support System

<http://www.rohm.com/contact/>