



Chipsmall Limited consists of a professional team with an average of over 10 year of expertise in the distribution of electronic components. Based in Hongkong, we have already established firm and mutual-benefit business relationships with customers from,Europe,America and south Asia,supplying obsolete and hard-to-find components to meet their specific needs.

With the principle of “Quality Parts,Customers Priority,Honest Operation,and Considerate Service”,our business mainly focus on the distribution of electronic components. Line cards we deal with include Microchip,ALPS,ROHM,Xilinx,Pulse,ON,Everlight and Freescale. Main products comprise IC,Modules,Potentiometer,IC Socket,Relay,Connector.Our parts cover such applications as commercial,industrial, and automotives areas.

We are looking forward to setting up business relationship with you and hope to provide you with the best service and solution. Let us make a better world for our industry!



Contact us

Tel: +86-755-8981 8866 Fax: +86-755-8427 6832

Email & Skype: info@chipsmall.com Web: www.chipsmall.com

Address: A1208, Overseas Decoration Building, #122 Zhenhua RD., Futian, Shenzhen, China



ROHM Switching Regulator Solutions Evaluation Board: Step-down Switching Regulator With Built-in Power MOSFET



BD9328EFJ / BD9329AEFJ (12V | 2A / 3A Output)

No.000000014

●Introduction

This application note will provide the steps necessary to operate and evaluate ROHM's step-down switching regulator using the BD9328EFJ/BD9329AEFJ evaluation boards. Component selection, board layout recommendations, operation procedures and application data is provided.

●Description

This evaluation board has been developed for ROHM's step-down switching regulator customers evaluating BD9328EFJ and/or BD9329AEFJ. While accepting a wide power supply of 4.2-18V, a step down output of 3.3V or any external resistor defined voltage can be produced. The ICs have two integrated low resistance N-channel MOSFETs and a fixed synchronization frequency of 380 kHz. A Soft Start circuit prevents in-rush current during startup along with UVLO (low voltage error prevention circuit) and TSD (thermal shutdown detection) protection circuits. An EN pin allows for simple ON/OFF control of the IC to reduce standby current consumption.

●Applications

Distributed Power Systems
Pre-regulator for linear regulators

●Evaluation Board Operating Limits and Absolute Maximum Ratings

Parameter	Symbol	Limit			Unit	Conditions
		MIN	TYP	MAX		
Supply Voltage						
	BD9328EFJ	VCC	4.2	12	18	V
	BD9329AEFJ	VCC	4.2	12	18	V
Output Voltage / Current						
	BD9328EFJ	VOUT	-	3.3V	-	V
	BD9329AEFJ	VOUT	-	3.3V	-	V
	BD9328EFJ	IOUT	-	-	2	A
	BD9329AEFJ	IOUT	-	-	3	A

●Evaluation Board

Below is the evaluation board with the BD9328EFJ. BD9329AEFJ eval board uses the same components and board layout

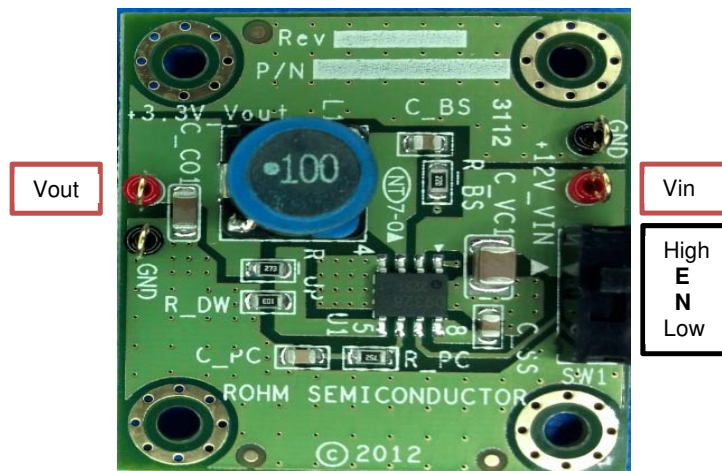

●Reference Graphs Application Data for BD9328EFJ

Below graphs shows load characteristics, transient responses and efficiency of the BD9328/9 eval board.

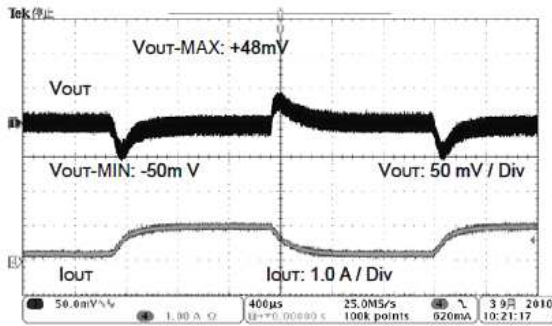

Transient Response
(VIN= 12V Vout= 3.3V L= 10µH Cout =20µF Iout= 0.2-1.0A)

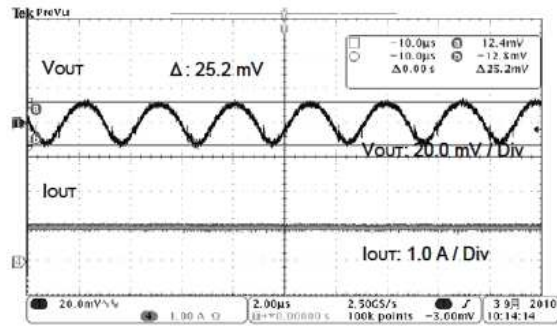

Output Ripple Voltage
(VIN= 12V Vout= 3.3V L= 10µH Cout =20µF Iout= 1.0A)

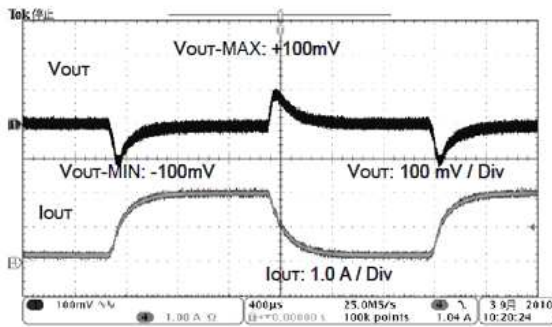

Transient Response
(VIN= 12V Vout= 3.3V L= 10µH Cout =20µF Iout= 0.2-2.0A)

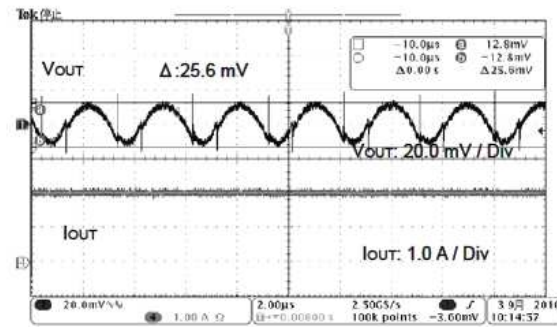

Output Ripple Voltage
(VIN= 12V Vout= 3.3V L= 10µH Cout =20µF Iout= 2.0A)

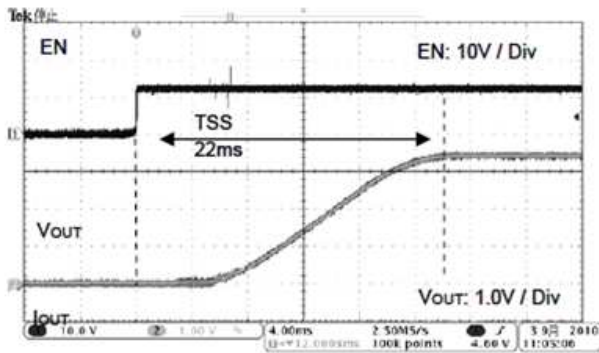

Start Up waveform
(VIN= 12V Vout= 3.3V L= 10µH Ccs= 0.1µF)

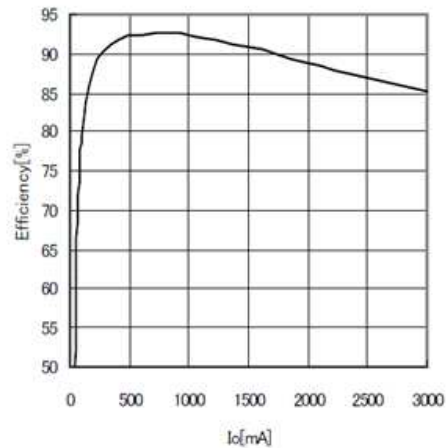

STEP Down Efficiency
(VIN= 12V Vout= 3.3V L=10µH)

●Reference Graphs Application Data for BD9329AEFJ

Below graphs shows the load characteristics, transient responses and efficiency of the BD9329AEFJ eval board.

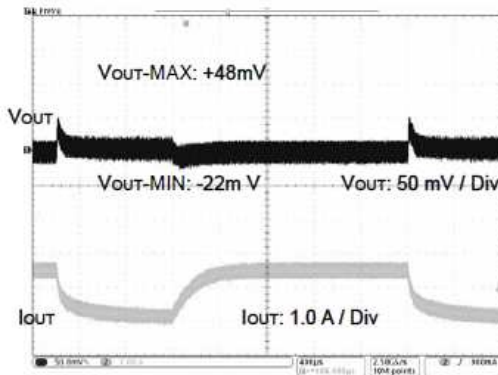

Transient Response
(VIN= 12V Vout= 3.3V L= 10μH Cout =22μF Iout= 0.2-1.0A)

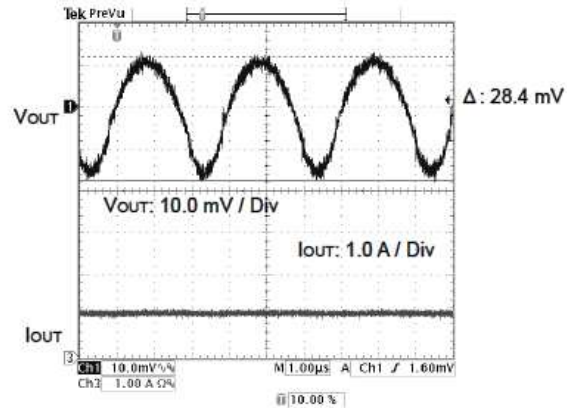

Output Ripple Voltage
(VIN= 12V Vout= 3.3V L= 10μH Cout =22μF Iout= 1.0A)

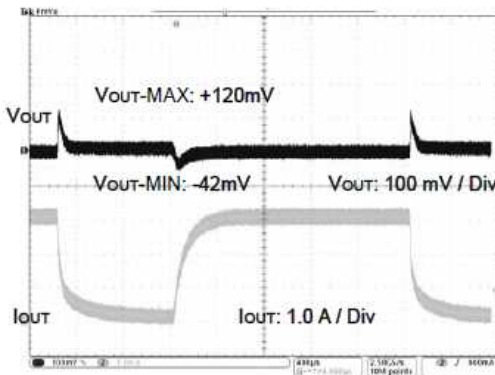

Transient Response
(VIN= 12V Vout= 3.3V L= 10μH Cout =22μF Iout= 0.2-3.0A)

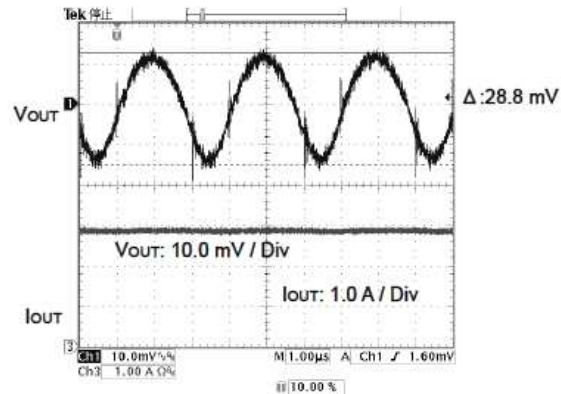

Output Ripple Voltage
(VIN= 12V Vout= 3.3V L= 10μH Cout =22μF Iout= 3.0A)

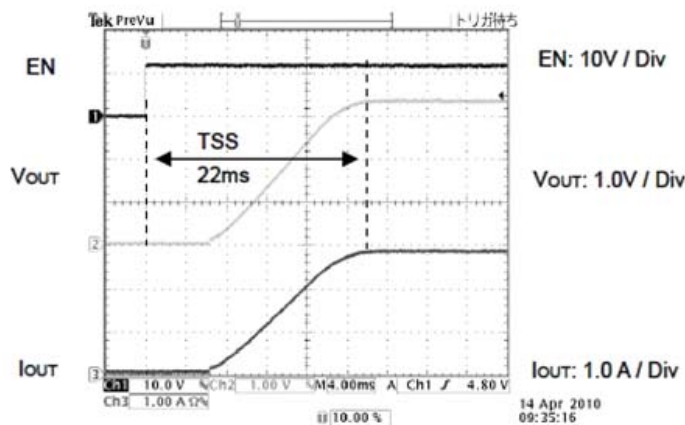

Start Up waveform
(VIN= 12V Vout= 3.3V L= 10μH C_{ss}= 0.1μF)

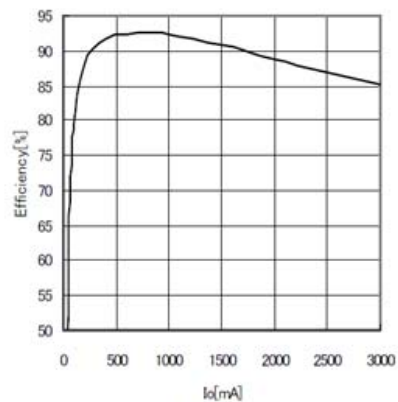

STEP Down Efficiency
(VIN= 12V Vout= 3.3V L=10μH)

●Evaluation Board Layout Guidelines

Below are the guidelines that have been followed and recommended for BD9328EFJ and BD9329AEFJ designs

Two high pulsing current flowing loops exist in the buck regulator system. The first loop, when FET is ON, starts from the input capacitors, to the VIN terminal, to the SW terminal, to the inductor, to the output capacitors, and then returns to the input capacitors through GND. The second loop, when FET is OFF, starts from the low FET, to the inductor, to the output capacitor, and then returns to the low FET through GND. To reduce the noise and improve the efficiency, please minimize these two loop area. Especially input capacitor, output capacitor and low FET should be connected to GND plain. PCB Layout may affect the thermal performance, noise and efficiency greatly. So please take extra care when designing PCB Layout patterns.

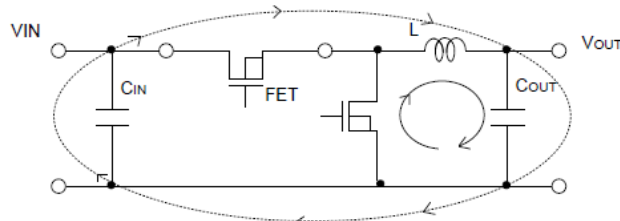

Fig.25 Current loop in Buck regulator system

- The thermal Pad on the back side of IC has the great thermal conduction to the chip. So using the GND plain as broad and wide as possible can help thermal dissipation. And a lot of thermal via for helping the spread of heat to the different layer is also effective.
- The input capacitors should be connected as close as possible to the VIN terminal.
- Keep sensitive signal traces such as trace connected FB and COMP away from SW pin.
- The inductor and the output capacitors should be placed close to SW pin as much as possible.

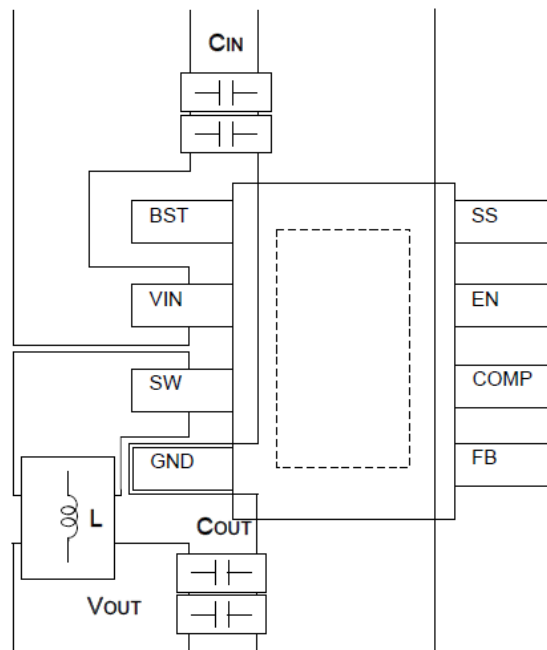

Fig.26 The example of PCB layout pattern

Note:

For applications operating at or near maximum voltage conditions (20V max.), additional precautions regarding heat dissipation need to be considered during board layout. The provided evaluation board is a 2-layer board meant for evaluation purposes only. At maximum conditions, the IC's internal thermal shutdown detection circuit will be potentially initiated and the output disabled until the junction temperature falls. For final designs operating near these conditions, we recommend using one of the below PCB options for better heat dissipation of the IC.

- 1) Use of a 4-layer PCB with internal GND planes connected to the IC GND pins
- 2) Use of a 2-layer PCB with a heat sink attached to the IC package
- 3) Use of a 2-layer PCB with a copper plane (>1oz) attached to the IC

● Selecting Application Components

(1) Output LC filter constant selection (Buck Converter)

The Output LC filter is required to supply constant current to the output load. A larger value inductance at this filter results in less inductor ripple current(ΔI_L) and less output ripple voltage. However, the larger value inductors tend to have less fast load transient-response, a larger physical size, a lower saturation current and higher series resistance. A smaller value inductance has almost opposite characteristics above. So Choosing the Inductor ripple current(ΔI_L) between 20 to 40% of the averaged inductor current (equivalent to the output load current) is a good compromise.

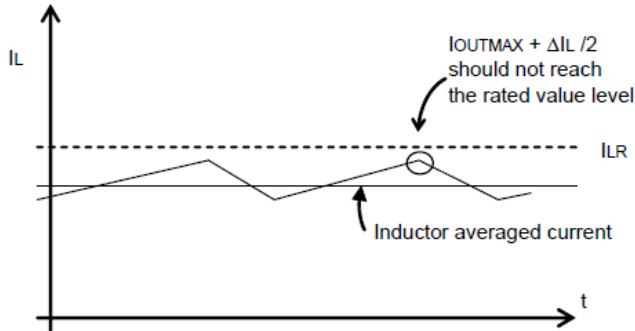

Fig.18

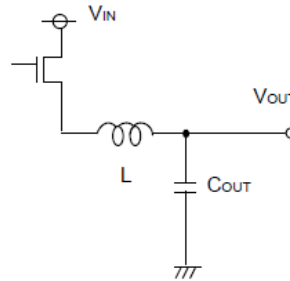

Fig.19

Setting $\Delta I_L = 30\% \times$ Averaged Inductor current (2A) = 0.6 [A]

$$L = \frac{V_{OUT} \times (V_{IN} - V_{OUT}) \times 1}{V_{IN} \times F_{OSC} \times \Delta I_L} = 10\mu [H]$$

Where $V_{IN}= 12V$, $V_{OUT}= 3.3V$, $F_{OSC}= 380$ kHz,
; F_{OSC} is a switching frequency

Also the inductor should have the higher saturation current than $I_{OUTMAX} + \Delta I_L / 2$.

The output capacitor C_{OUT} affects the output ripple-voltage. Choose the large capacitor to achieve the small ripple-voltage enough to meet the application requirement.

Output ripple voltage ΔV_{RPL} is calculated by the following equation.

$$\Delta V_{RPL} = \Delta I_L \times (R_{ESR} + \frac{1}{8 \times C_{OUT} \times F_{OSC}}) [V]$$

Where R_{ESR} is a parasitic series resistance in output capacitor.

Setting $C_{OUT} = 20\mu F$, $R_{ESR} = 10m\Omega$

$$\Delta V_{RPL} = 0.6 \times (10m + 1 / (8 \times 20\mu \times 380k)) = 15.8mV$$

(2) Loop Compensation

Choosing compensation capacitor C_{CMP} and resistor R_{CMP}

The current-mode buck converter has 2-poles and 1-zero system. Choosing the compensation resistor and capacitor is important for a good load-transient response and good stability. The example of DC/DC converter application bode plot is shown below.

The compensation resistor R_{CMP} will decide the cross over frequency F_{CRS} (the frequency that the total DC-DC loop-gain falls to 0dB).

Setting the higher cross over frequency achieves good response speed, however less stability. While setting the lower cross over frequency shows good stability but worse response speed.

The 1/10 of switching frequency for the cross over frequency shows a good performance at most applications.

(i) Choosing phase compensation resistor R_{CMP}

The compensation resistor R_{CMP} can be on following formula.

$$R_{CMP} = \frac{2\pi \times V_{OUT} \times F_{CRS} \times C_{OUT}}{V_{FB} \times G_{MP} \times G_{MA}} \quad [\Omega]$$

Where

V_{OUT} ; Output voltage, F_{CRS} ; Cross over frequency, C_{OUT} ; Output Capacitor,
 V_{FB} ; internal feedback voltage (0.9V(TYP)), G_{MP} ; Current Sense Gain (7.8A/V(TYP)),
 G_{MA} ; Error Amplifier Trans-conductance (300μA/V(TYP))

Setting $V_{OUT}= 3.3V$, $F_{CRS}= 38kHz$, $C_{OUT}= 20\mu F$;

$$R_{CMP} = \frac{2\pi \times 3.3 \times 38k \times 20u}{0.9 \times 7.8 \times 300u} = 7.48k \approx 7.5k \quad [\Omega]$$

(ii) Choosing phase compensation capacitor C_{CMP}

For the stability of DC/DC converter, canceling the phase delay that derives from output capacitor C_{OUT} and resistive load R_{OUT} by inserting the phase advance.

The phase advance can be added by the zero on compensation resistor R_{CMP} and capacitor C_{CMP} .

Making $F_z = F_{CRS} / 6$ gives a first-order estimate of C_{CMP} .

$$\text{Compensation Capacitor} \quad C_{CMP} = \frac{1}{2\pi \times R_{CMP} \times F_z} \quad [F]$$

Setting $F_z = F_{CRS}/6 = 6.3kHz$;

$$\text{Compensation Capacitor} \quad C_{CMP} = \frac{1}{2\pi \times 7.5k \times 6.3k} = 3.54n \approx 3.3n \quad [F]$$

(iii) The condition of the loop compensation stability

The stability of DC/DC converter is important. To secure the operating stability, please check the loop compensation has the enough phase-margin. For the condition of loop compensation stability, the phase-delay must be less than 150 degree where Gain is 0 dB.

Feed forward capacitor C_{RUP} boosts phase margin over a limited frequency range and is sometimes used to improve loop response. C_{RUP} will be more effective if $R_{UP} \gg R_{UP} || R_{DW}$

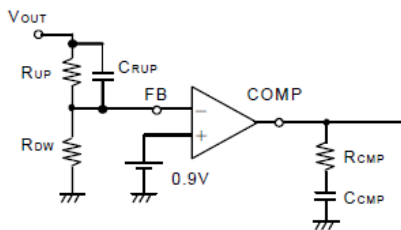

Fig.20

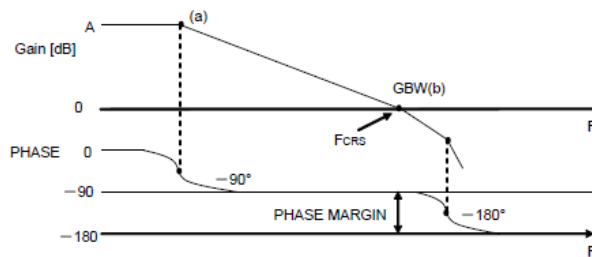
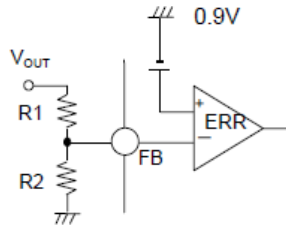

Fig.21

- (3) Design of Feedback Resistance constant
Set the feedback resistance as shown below.



$$V_{OUT} = \frac{R1 + R2}{R2} \times 0.9 \quad [V]$$

Fig.22

●Evaluation Board BOM

Below is a table with the build of materials. Part numbers and supplier references are provided.

Item	Qty	Ref	Description	Manufacturer	Part Number	Digikey P/N
1	1	C_CO1	CAP CER 22UF 16V 20% 1206	TDK Corporation	C3216X6S1C226M	445-8044-6-ND
2	1	C_PC	CAP CER 3300PF 100V 10% X7R 0805	TDK Corporation	C2012X7R2A332K	445-4431-2-ND
3	1	C_VC1	CAP CER 10UF 25V 10% 1210	TDK Corporation	C3225JB1E106K	445-3946-6-ND
4	1	L1	INDUCTOR SHIELD PWR 10UH SMD	TDK Corporation	C3225Y5V1H106Z	445-6478-6-ND
5	2	C _{SS} , C _{bs}	CAP CER 0.1UF 25V 10% X7R 0805	TDK Corporation	C2012X7R1E104K/1.25	445-1351-2-ND
6	1	RBS	RES 22 OHM 1/8W 5% 0805 SMD	ROHM Semiconductor	MCR10EZJ220	RHM22ATR-ND
7	1	RDW	RES 10K OHM 1/8W 5% 0805 SMD	ROHM Semiconductor	MCR10ERTJ103	RHM10KCLTR-ND
8	1	RPC	RES 7.5K OHM 1/8W 5% 0805 SMD	ROHM Semiconductor	MCR10EZPJ752	RHM7.5KARTR-ND
9	1	RUP	RES 27K OHM 1/8W 5% 0805 SMD	ROHM Semiconductor	MCR10EZJ273	RHM27KATR-ND
10	1	U1	IC REG BUCK SYNC ADJ 2A 8HTSOP	ROHM Semiconductor	BD9328EFJ-E2	BD9328EFJ-E2TR-ND
11	1	U1	IC REG BUCK SYNC ADJ 3A 8HTSOP	ROHM Semiconductor	BD9329AEFJ-E2	BD9329AEFJ-E2TR-ND



Note: In this example, the nominal resistance values of R1 and R2 were selected to set a 3.3 V output.

Notes

No copying or reproduction of this document, in part or in whole, is permitted without the consent of ROHM Co.,Ltd.

The content specified herein is subject to change for improvement without notice.

The content specified herein is for the purpose of introducing ROHM's products (hereinafter "Products"). If you wish to use any such Product, please be sure to refer to the specifications, which can be obtained from ROHM upon request.

Examples of application circuits, circuit constants and any other information contained herein illustrate the standard usage and operations of the Products. The peripheral conditions must be taken into account when designing circuits for mass production.

Great care was taken in ensuring the accuracy of the information specified in this document. However, should you incur any damage arising from any inaccuracy or misprint of such information, ROHM shall bear no responsibility for such damage.

The technical information specified herein is intended only to show the typical functions of and examples of application circuits for the Products. ROHM does not grant you, explicitly or implicitly, any license to use or exercise intellectual property or other rights held by ROHM and other parties. ROHM shall bear no responsibility whatsoever for any dispute arising from the use of such technical information.

The Products specified in this document are intended to be used with general-use electronic equipment or devices (such as audio visual equipment, office-automation equipment, communication devices, electronic appliances and amusement devices).

The Products specified in this document are not designed to be radiation tolerant.

While ROHM always makes efforts to enhance the quality and reliability of its Products, a Product may fail or malfunction for a variety of reasons.

Please be sure to implement in your equipment using the Products safety measures to guard against the possibility of physical injury, fire or any other damage caused in the event of the failure of any Product, such as derating, redundancy, fire control and fail-safe designs. ROHM shall bear no responsibility whatsoever for your use of any Product outside of the prescribed scope or not in accordance with the instruction manual.

The Products are not designed or manufactured to be used with any equipment, device or system which requires an extremely high level of reliability the failure or malfunction of which may result in a direct threat to human life or create a risk of human injury (such as a medical instrument, transportation equipment, aerospace machinery, nuclear-reactor controller, fuel-controller or other safety device). ROHM shall bear no responsibility in any way for use of any of the Products for the above special purposes. If a Product is intended to be used for any such special purpose, please contact a ROHM sales representative before purchasing.

If you intend to export or ship overseas any Product or technology specified herein that may be controlled under the Foreign Exchange and the Foreign Trade Law, you will be required to obtain a license or permit under the Law.



Thank you for your accessing to ROHM product informations.
More detail product informations and catalogs are available, please contact us.

ROHM Customer Support System

<http://www.rohm.com/contact/>