



Chipsmall Limited consists of a professional team with an average of over 10 year of expertise in the distribution of electronic components. Based in Hongkong, we have already established firm and mutual-benefit business relationships with customers from,Europe,America and south Asia,supplying obsolete and hard-to-find components to meet their specific needs.

With the principle of “Quality Parts,Customers Priority,Honest Operation,and Considerate Service”,our business mainly focus on the distribution of electronic components. Line cards we deal with include Microchip,ALPS,ROHM,Xilinx,Pulse,ON,Everlight and Freescale. Main products comprise IC,Modules,Potentiometer,IC Socket,Relay,Connector.Our parts cover such applications as commercial,industrial, and automotives areas.

We are looking forward to setting up business relationship with you and hope to provide you with the best service and solution. Let us make a better world for our industry!



## Contact us

Tel: +86-755-8981 8866 Fax: +86-755-8427 6832

Email & Skype: info@chipsmall.com Web: www.chipsmall.com

Address: A1208, Overseas Decoration Building, #122 Zhenhua RD., Futian, Shenzhen, China



LED Drivers for LCD Backlights

# White LED Driver for large LCD Panels (DCDC Converter type)

**BD93941EFV BD93941FP**

**General Description**

BD93941EFV and BD93941FP is a high efficiency driver for white LEDs and designed for large LCDs. These ICs are built-in a boost DCDC converters that employ an array of LEDs as the light source. BD93941EFV and BD93941FP have some protect function against fault conditions, such as the over-voltage protection (OVP), the over current limit protection of DCDC (OCP), the short circuit protection (SCP), the open detection of LED string. Therefore BD93941EFV and BD93941FP are available for the fail-safe design over a wide range output voltage.

**Key Specification**

- Operating power supply voltage range: 9.0V to 35.0V
- LED minimum current 30mA
- LED maximum current: 200mA
- Oscillator frequency: 150kHz (RT=100kΩ)
- Operating Current: 4.5mA (Typ.)
- Operating temperature range: -40°C to +85°C

**Features**

- 4ch LED constant current driver and DC/DC converter
- Maximum LED Current: 200mA
- LED Feedback Voltage: 0.37V (@ADIM=2.5V) so lower heat. Adjustable Feed Back Voltage by following LED Current setting.
- ±2% LED current accuracy (ADIM=2.5V, when each LED is set to 100mA)
- Analog current (Linear) dimming at ADIM pin
- LED pin rating 60V
- Individual detection and individual LED OFF for both open and short circuits
- Built-in ISET pin short-circuit protection circuit
- Set Soft-Start time by external capacitor.
- FET's Gate (N pin) is driven by 5.8V swing
- Built-in Vout discharge circuit for shutdown
- Built-in Vout overvoltage protection (OVP) / reduced voltage protection (SCP) circuit
- HTSSOP-B20 and HSOP20 package with high heat radiation efficiency

**Applications**

TV, Computer Display, Notebook, LCD Backlighting

**Package**

HTSSOP-B20  
HSOP20

W(Typ.) x D(Typ.) x H(Max.)  
6.50mm x 6.40mm x 1.00mm  
14.90mm x 7.80mm x 2.10mm



Figure 1(a). HTSSOP-B20 (BD93941EFV)



Figure 1(b). HSOP20 (BD93941FP)

**Typical Application Circuit**

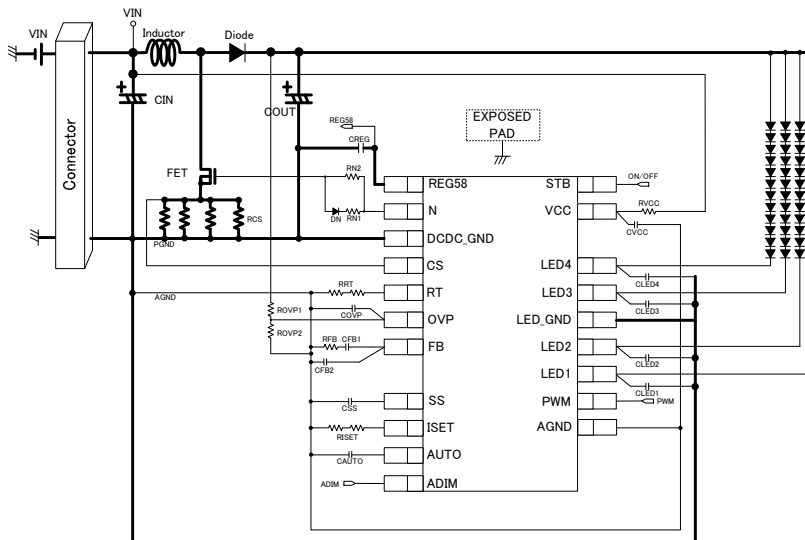

Figure 2. Typical Application Circuit

○Product structure : Silicon monolithic integrated circuit ○This product has not designed protection against radioactive rays

**Absolute maximum ratings (Ta=25°C)**

Parameter	Symbol	Ratings	Unit
Power supply voltage	VCC	36	V
STB, ADIM, OVP, PWM terminal voltage	STB, ADIM, OVP, PWM	36	V
LED1 to 4 terminal voltage	LED1 to 4	60	V
AUTO, REG58, CS, N, ISET, SS, FB, RT terminal voltage	AUTO, REG58, CS, N, ISET, SS, FB, RT	7	V
Power dissipation (HTSSOP-B20) (HSOP20)	Pd1 Pd2	3.20 *1 2.18 *2	W
Operating temperature range	Topr	-40 to +85	°C
Storage temperature range	Tstg	-55 to +150	°C
Junction temperature	Tjmax	150	°C

\*1 Ta = 25°C or more, diminished at -25.6mW/°C in the case of HTSSOP-B20 (when 4-layer / 70.0 mm x 70.0 mm x 1.6 mm board is mounted)

\*2 Ta = 25°C or more, diminished at -17.4mW/°C in the case of HSOP20 (when 4-layer / 70.0 mm x 70.0 mm x 1.6 mm board is mounted)

**Operating Ratings**

Parameter	Symbol	Limits	Unit
VCC supply voltage	VCC	9.0 to 35.0	V
Min. output current of LED1 to 4	ILED_MIN	30	mA *1
Max. output current of LED1 to 4	ILED_MAX	200	mA *1,2
ADIM input voltage1 (use ADIM function)	VADIM1	0.2 to 2.7 (normal op.) 1.0 to 2.7 (start up)	V *3
ADIM input voltage1 (don't use ADIM function)	VADIM2	REG58 to 35.0	V
DC/DC oscillation frequency	Fsw	100 to 800	kHz
Min. on-duty time for PWM light modulation	PWM_MIN	30	µs

\*1 The amount of current per channel.

\*2 If LED makes significant variations in its reference voltage, the driver will increase power dissipation, resulting in a rise in package temperature.

To avoid this problem, design the board with thorough consideration given to heat radiation measures.

\*3 To avoid unused LED pin's misdetection, set ADIM within 1.0V to 2.7V at start up stage. After unused LED pin's detection, set ADIM within 0.2V to 2.7V in normal operation.

**Pin Configuration**

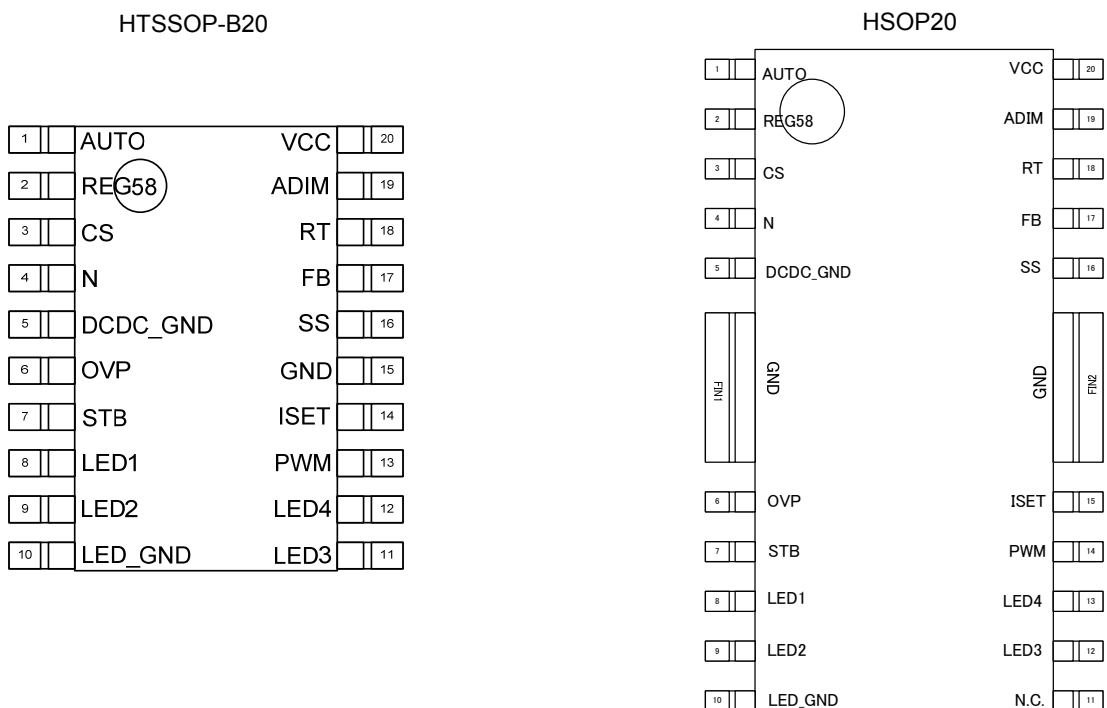

Figure 3. Pin Configuration



Marking diagram and physical dimension

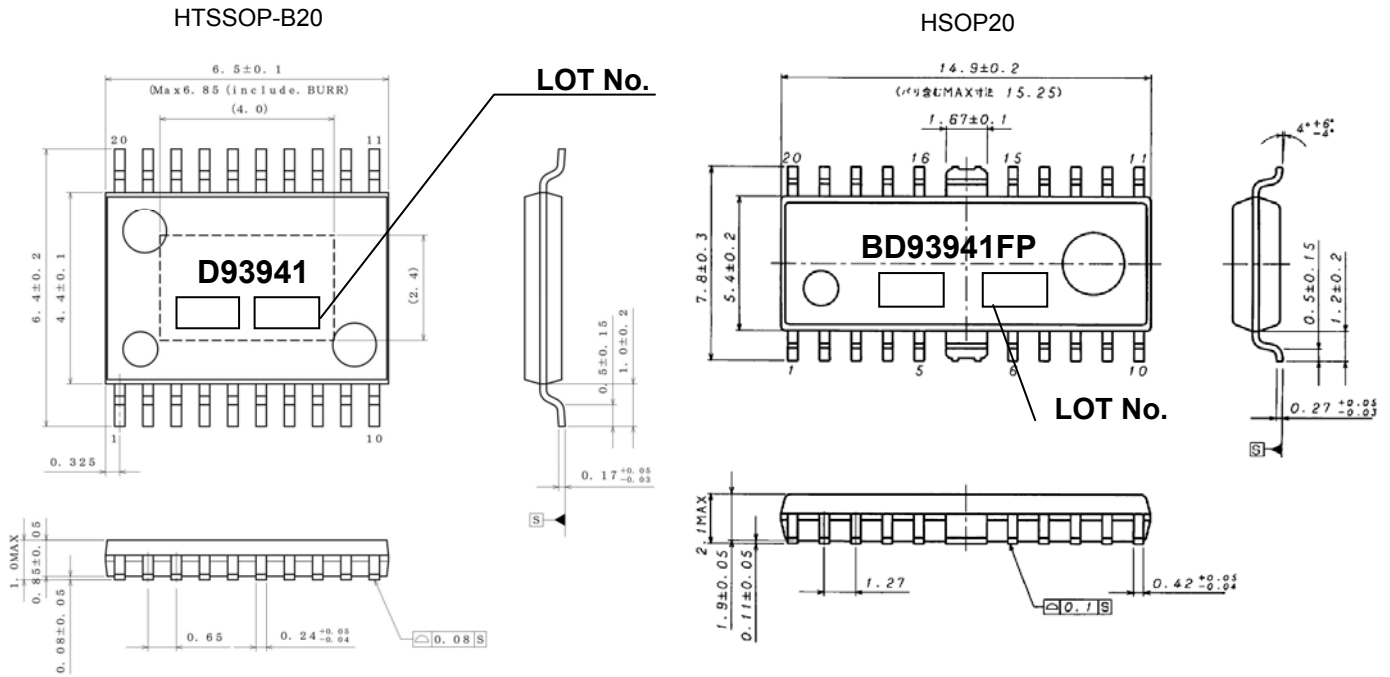

Figure 4. Physical Dimension

Electrical Characteristics (Unless otherwise noted, Ta = 25°C, VCC=24V)

Parameter	Symbol	Limit			Unit	Condition
		Min.	Typ.	Max.		
<b>[Whole Device]</b>						
Circuit current while in operation	ICC	-	4.5	9	mA	STB=3V,PWM=3V, RT=100kΩ
Circuit current while in standby	ISTB	-	40	80	μA	STB=0V
<b>[REG58 Block]</b>						
REG58 Output Voltage	REG58	5.742	5.8	5.858	V	IO=0mA
REG58 available current	I <sub>REG58</sub>	15	-	-	mA	
<b>[UVLO Block]</b>						
UVLO release voltage	V <sub>UVLO_VCC</sub>	6.5	7.5	8.5	V	VCC=SWEEP UP
UVLO hysteresis voltage	V <sub>UHYS_VCC</sub>	150	300	600	mV	VCC=SWEEP DOWN
<b>[DC/DC Block]</b>						
Error amp. Reference voltage	VLED	0.35	0.37	0.39	V	ISET=75kΩ, ADIM=2.5V
Oscillation frequency	fsw	142.5	150.0	157.5	kHz	RT=100kΩ
Max. duty cycle per output of N pin	D <sub>MAX</sub>	83	90	97	%	RT=100kΩ
On resistance on N pin source side	R <sub>ONH</sub>	-	4	8	Ω	I <sub>ON</sub> =-10mA
On resistance on N pin sink side	R <sub>ONL</sub>	-	3	6	Ω	I <sub>ON</sub> =10mA
SS pin source current	I <sub>SSSO</sub>	-4	-2	-1	uA	SS=2V
Soft start completion voltage	V <sub>SS_END</sub>	3.3	3.7	4.1	V	SS=SWEEP UP
FB sink current	I <sub>FBSINK</sub>	50	100	150	μA	LED=2.0V, FB=1.0V
FB source current	I <sub>FBSOURCE</sub>	-150	-100	-50	μA	LED=0V, FB=1.0V
Over current detection voltage	VCS	0.40	0.45	0.50	V	CS=SWEEP UP

## Electrical Characteristics (Unless otherwise noted, Ta = 25°C, VCC=24V)

Parameter	Symbol	Limit			Unit	Condition
		Min.	Typ.	Max.		
<b>[DC/DC Protection Block]</b>						
Overvoltage protection detection voltage	VOVP	2.7	3.00	3.3	V	OVP=SWEEP UP
Overvoltage protection detection hysteresis voltage	VOVP_HYS	50	100	200	mV	OVP=SWEEP DOWN
Short circuit protection detection voltage	VSCP	0.04	0.10	0.25	V	OVP=SWEEP DOWN
<b>[LED Driver Block]</b>						
LED pin current accuracy 1	dILED1	-2	-	2	%	ILED=100mA, (ADIM=2.5V,ISET=75kΩ)
LED pin current accuracy 2	dILED2	-3.2	-	3.2	%	ILED=70mA, (ADIM=1.75V,ISET=75kΩ)
LED pin current accuracy 3	dILED3	-4.6	-	4.6	%	ILED=50mA, (ADIM=1.25V,ISET=75kΩ)
LED pin current accuracy 4	dILED4	-8	-	8	%	ILED=30mA, (ADIM=0.75V,ISET=75kΩ)
LED pin current accuracy 5	dILED5	-3	-	3	%	ILED=100mA, (ADIM=7V,ISET=75kΩ)
LED pin Leakage Current	ILLED	-2.5	-	2.5	μA	LED=60V
LED open detection voltage	VOPEN	0.05	0.2	0.285	V	LED=SWEEP DOWN
LED short detection voltage	VSHORT	4	5	6	V	LED=SWEEP UP
ADIM pin Input Current	ILADIM	-2.5	-	2.5	μA	ADIM=3V
<b>[STB Block]</b>						
STB pin high-level voltage	STBH	2	-	35	V	STB=SWEEP UP
STB pin low-level voltage	STBL	-0.3	-	0.8	V	STB=SWEEP DOWN
STB pin pull-down resistance	RSTB	500	1000	1500	kΩ	STB=3.0V
<b>[PWM Block]</b>						
PWM pin high-level voltage	PWMH	2	-	35	V	PWM=SWEEP UP
PWM pin low-level voltage	PWML	-0.3	-	0.8	V	PWM= SWEEP DOWN
PWM pin pull-down resistance	RPWM	180	300	420	kΩ	PWM=3.0V
<b>[Failure Indication Block (Open Drain)]</b>						
AUTO pin source current	IAUTO	-2	-1	-0.5	μA	AUTO=2V
AUTO pin Detection Voltage	VAUTO	3.6	4.0	4.4	V	AUTO=SWEEP UP
Abnormal Detection Timer	tCP		20		ms	RT=75kΩ

## Pin Descriptions (BD93941EFV)

Pin No	Pin Name	In/Out	Function	Rating [V]
1	AUTO	Out	Auto-restart time setting pin	-0.3 to 7
2	REG58	Out	Power supply for N pin	-0.3 to 7
3	CS	In	DC/DC output current detection and OCP detection pin	-0.3 to 7
4	N	Out	DC/DC switching output pin	-0.3 to 7
5	DCDC_GND	-	Power GND pin	-
6	OVP	In	Overvoltage protection detection pin	-0.3 to 36
7	STB	In	Enable pin	-0.3 to 36
8	LED1	Out	Output pin 1 for LED	-0.3 to 60
9	LED2	Out	Output pin 2 for LED	-0.3 to 60
10	LED_GND	-	Ground pin for LED	-
11	LED3	Out	Output pin 3 for LED	-0.3 to 60
12	LED4	Out	Output pin 4 for LED	-0.3 to 60
13	PWM	In	External PWM light modulation signal input pin for LED1-4	-0.3 to 36
14	ISET	Out	LED current setting resistor connection pin	-0.3 to 7
15	GND	-	Analog GND pin	-
16	SS	Out	Soft start pin / LED protection masking time setting pin.	-0.3 to 7
17	FB	In/Out	Error amp output pin	-0.3 to 7
18	RT	Out	DC/DC drive frequency setting resistor connection pin.	-0.3 to 7
19	ADIM	In	Analog dimming DC voltage input pin	-0.3 to 36
20	VCC	In	Power supply pin	-0.3 to 36

## Pin Descriptions (BD93941FP)

Pin No	Pin Name	In/Out	Function	Rating [V]
1	AUTO	Out	Auto-restart time setting pin	-0.3 ~ 7
2	REG58	Out	Power supply for N pin	-0.3 ~ 7
3	CS	In	DC/DC output current detection and OCP detection pin	-0.3 ~ 7
4	N	In	DC/DC switching output pin	-0.3 ~ 7
5	DCDC_GND	-	Power GND pin	-
FIN1	GND	-		-
6	OVP	In	Overvoltage protection detection pin	-0.3 ~ 36
7	STB	In	Enable pin	-0.3 ~ 36
8	LED1	Out	Output pin 1 for LED	-0.3 ~ 60
9	LED2	Out	Output pin 2 for LED	-0.3 ~ 60
10	LED_GND	-	Ground pin for LED	-
11	N.C.	-	Non connection pin	-
12	LED3	Out	Output pin 3 for LED	-0.3 ~ 60
13	LED4	Out	Output pin 4 for LED	-0.3 ~ 60
14	PWM	In	External PWM light modulation signal input pin for LED1-4	-0.3 ~ 36
15	ISET	Out	LED current setting resistor connection pin	-0.3 ~ 7
FIN2	GND	-	Analog GND pin	-
16	SS	Out	Soft start pin / LED protection masking time setting pin.	-0.3 ~ 7
17	FB	In/Out	Error amp output pin	-0.3 ~ 7
18	RT	Out	DC/DC drive frequency setting resistor connection pin.	-0.3 ~ 7
19	ADIM	In	Analog dimming DC voltage input pin	-0.3 ~ 36
20	VCC	In	Power supply pin	-0.3 ~ 36

Pin ESD Type

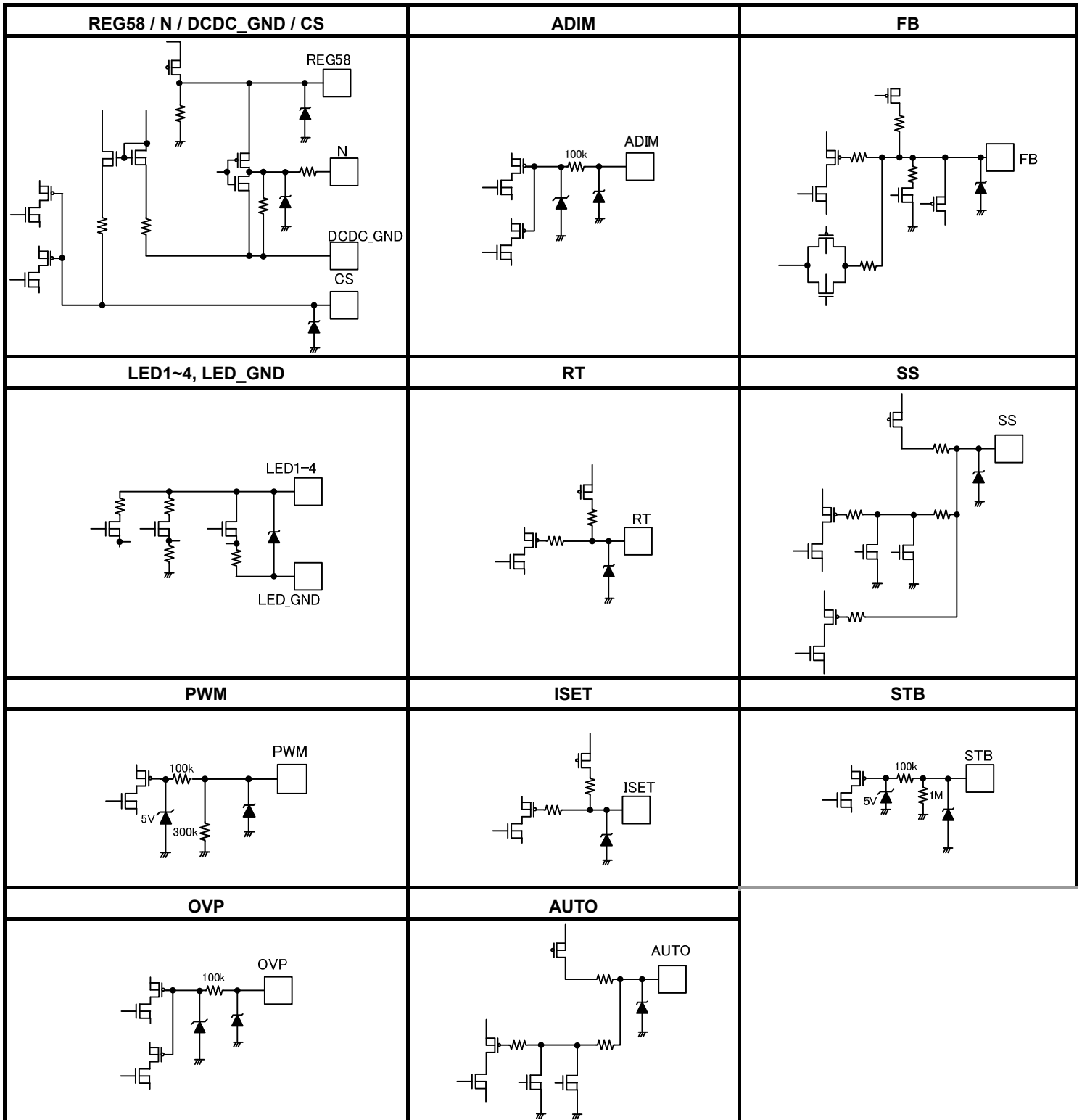

Figure 5. Pin ESD Type

Block Diagram

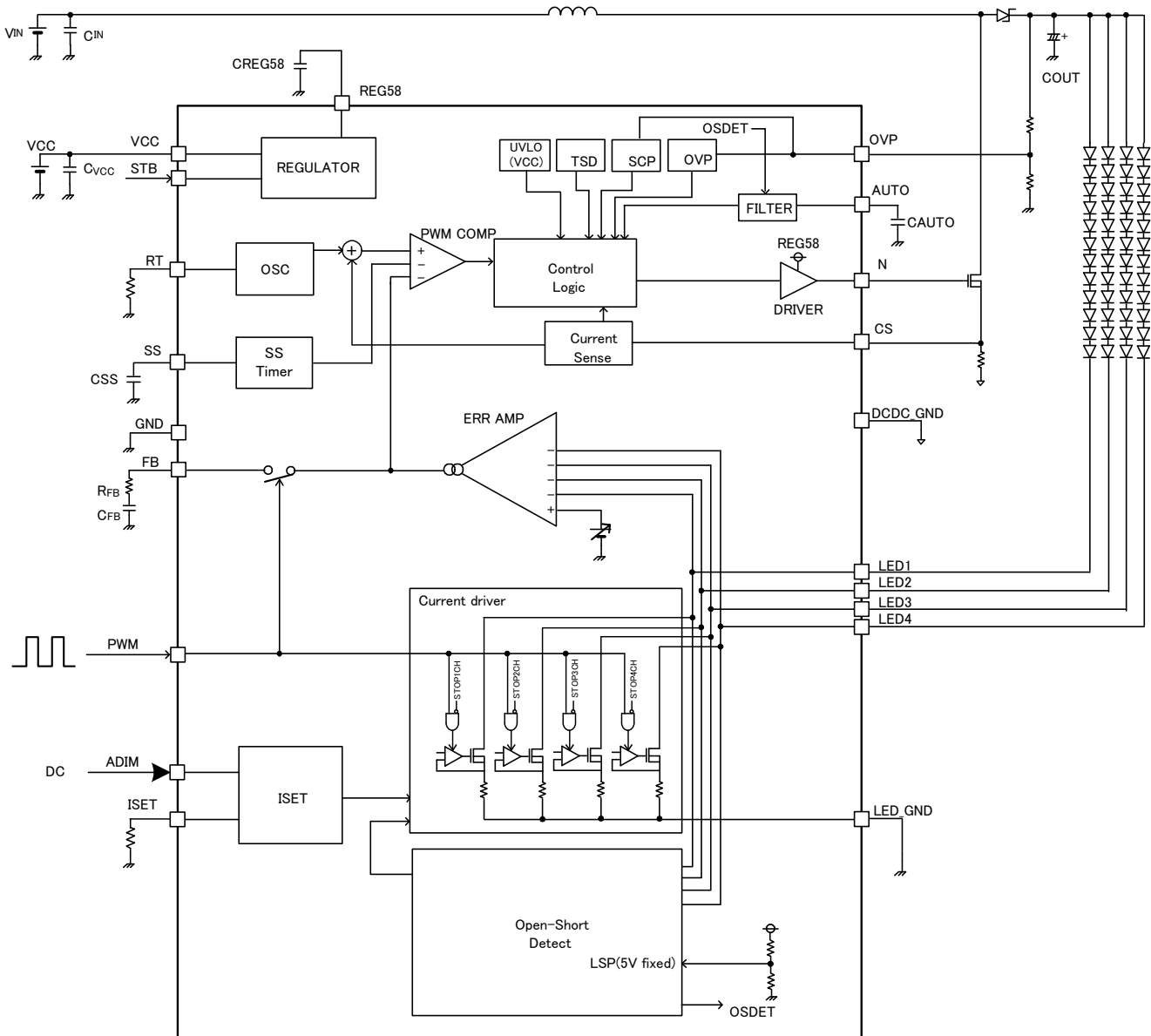

Figure 6. Block Diagram



Typical Performance Curve

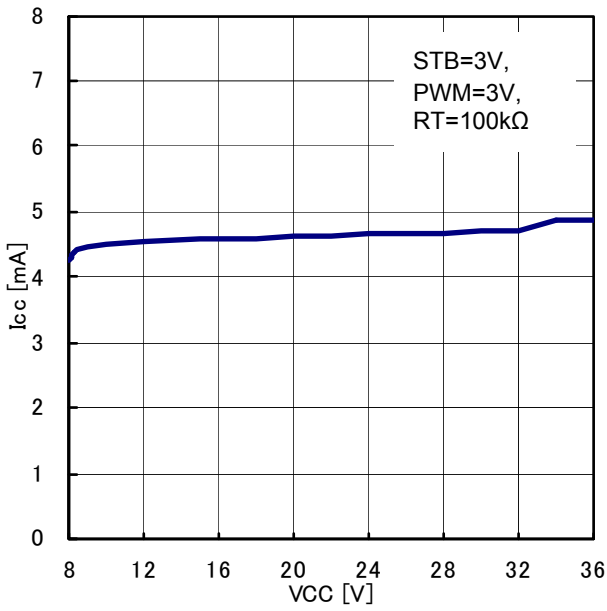

Figure 7. Operating Current (ICC) [mA] vs. VCC[V]

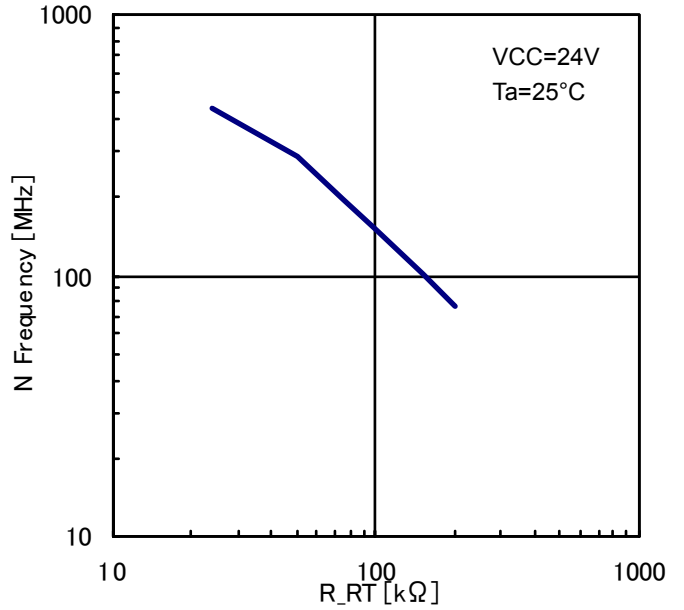

Figure 8. N Frequency [MHz] vs. R\_RT [kΩ]

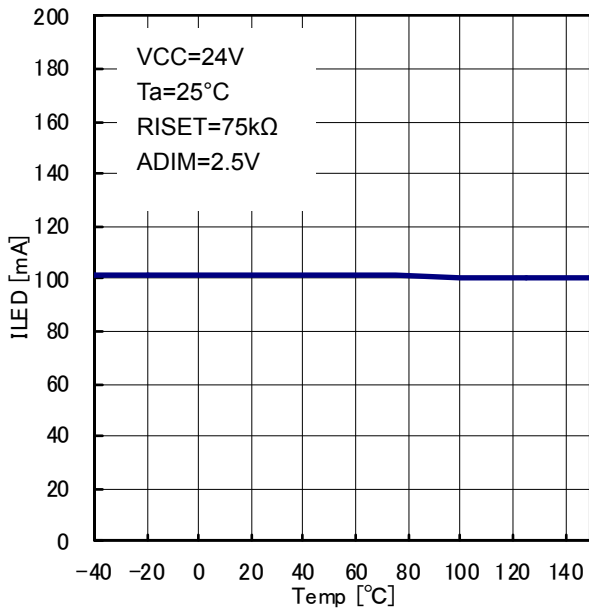

Figure 9. LED Current (ILED) [mA] vs. Temp [°C]

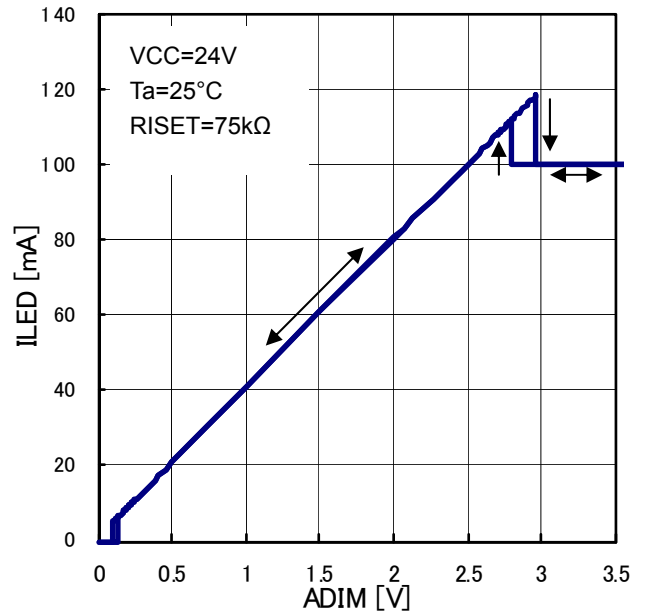

Figure 10. LED Current (ILED) [mA] vs. ADIM[V],

**Pin Function**○ **AUTO (1pin)**

This sets up time till auto-restart time from the point of abnormal detection. Having 1μA constant current charge at external capacitor connected to AUTO pin, it will start again when it becomes over 4.0V (The auto pin is shorted to GND, this IC's protection function operates latched off mode).

○ **Auto-restart period vs. AUTO capacitance (Ideal)**

$$T_{AUTO} = \frac{4.0[V] \times C_{AUTO}}{1.0 \times 10^{-6}[A]} = 4.0 \times 10^6 \times C_{AUTO} [\text{sec}]$$

○ **REG58 (2pin)**

The REG58 pin is used in the DC/DC converter driver block to output 5.8V power. The maximum operating current is 15mA. Using the REG58 pin at a current higher than 15mA can affect the N pin output pulse, causing the IC to malfunction and leading to heat generation of the IC itself. To avoid this problem, it is recommended to make load setting to the minimum level.

Please place the ceramic capacitor connected to REG58 pin (2.2μF~10μF) closest to REG58-GND pin.

○ **CS (3pin)**

The CS pin has the following two functions:

1. DC/DC current mode current feedback function

Current flowing through the inductor is converted into voltage by the current sensing resistor RCS connected to the CS pin and this voltage is compared with voltage set with the error amplifier to control the DC/DC output voltage.

2. Inductor current limit function

The CS pin also incorporates the over current protection (OCP) function. If the CS pin voltage reaches 0.45V (Typ.) or more, switching operation will be forcedly stopped.

○ **N (4pin)**

The N pin is used to output power to the external NMOS gate driver for the DC/DC converter in the amplitude range of approx. 0 to REG58. ON resistances is 4.0Ω(typ.) in source (H side), 3.0Ω(typ.) in sink (L side).

Frequency setting can be made with a resistor connected to the RT pin. For details of frequency setting, refer to the description of the RT pin.

○ **DCDC\_GND (5pin)**

The PGND pin is a power ground pin for the driver block of the output pin N.

○ **OVP (6pin)**

The OVP pin is an input pin for over-voltage protection and short circuit protection of DC/DC output voltage. If over-voltage is detected, the OVP pin will stop the DC/DC converter conducting step-up operation. When the short circuit protection (SCP) function is activated, the DC/DC converter will stop operation, and then the timer will start counting. When the timer completes counting the preset period of time, the LED drivers are stopped.

The OVP pin is of the high impedance type and involves no pull-down resistor, resulting in unstable potential in the open-circuited state. To avoid this problem, be sure to make input voltage setting with the use of a resistive divider or otherwise.

○ **STB (7pin)**

The STB pin is used to make setting of turning ON and OFF the IC and allowed for use to reset the IC from shutdown.

Note: The IC state is switched (i.e., the IC is switched between ON and OFF state) according to voltages input in the STB pin. Avoid using the STB pin between two states (0.8 to 2.0V).

○ **LED1 – LED4 (8,9,11,12pin)**

The LED1 to 4 pins are used to output constant current to LED drivers. Current value setting can be made by connecting a resistor to the ISET pin. For the current value setting procedure, refer to the description of "ISET pin".

If any of the LED pins is put in an erroneous state (e.g. short circuit mode, open circuit mode, or ground short circuit mode), the relevant protection function will be activated.

○ **LED\_GND (10pin)**

The LED\_GND pin is a power ground pin used for the LED driver block.

○ **PWM (13pin)**

The PWM pin is used to turn ON and OFF LED drivers. Light can be modulated by changing the duty cycle through the direct input of a PWM light modulation signal. The high and low voltage levels of PWM pin is as listed in the table below:

State	PWM Voltage
LED ON state	PWM= 2.0V to 35V
LED OFF state	PWM= -0.3V to 0.8V

○ **ISET (14pin)**

The ISET pin is an output current setting resistor. Output current ILED varies in inverse proportion to resistance. The relation between output current ILED and the resistance of ISET pin connection resistor RISET is given by the following equation:

$$I_{LED} [mA] = \frac{3000}{R_{ISET} [k\Omega]} \times V_{ADIM} [V] \quad (\text{ADIM}=0.2V \text{ to } 2.7V)$$

$$I_{LED} [mA] = \frac{7500}{R_{ISET} [k\Omega]} \quad (\text{ADIM}>4V \text{ to } 35V)$$

Output current setting should be made in the range of 30 to 200mA.

It prepares automatically to suitable LED feedback voltage that can output LED current set by ISET pin. In short LED feedback voltage is dropped when the LED current is small and the IC heating is held automatically. In case of a large current is needed, raise the LED pin feedback voltage. And it adjusts automatically to LED pin voltage that can be flow large LED current. The calculation is as below.

$$V_{LED} = 3.7 \times I_{LED} [A] [V]$$

The LED feedback voltage (VLED) is clamped to 0.3V (typ.) when the LED current (ILED) is less than 81.1mA.

ADIM input range is from 0V to 35V. And the range which the LED currents change with linearity is from 0.2V to 2.7V. When it reaches under VISET×0.90V(typ.), the LED current is off to prevent from passing a large current to the LED pin when the RISET is shorted and the ISET pin is shorted to the GND. And as the ISET pin returns to a normal state, the LED current returns.

○ **GND (15pin)**

The GND pin is an internal analog circuit ground of the IC.

○ **SS (16pin)**

The SS pin is used to make setting of soft start time and duty for soft start. It performs constant current charge of 2.0 uA to the external capacitor connected with SS terminal, which enables soft-start of DC/DC converter. Since the LED protection function (OPEN/SHORT detection) works when the SS terminal voltage reaches 3.7 V (typ.) or higher, it must be set to bring stability to conditions such as DC/DC output voltage and LED constant current drive operation, etc. before the voltage of 3.7 V is detected.

○ **FB (17pin)**

The FB pin is an output pin used for DC/DC current mode control error amplifier. In other words, the FB pin detects the voltages of LED pins (1 to 4) and controls inductor current so that the pin voltage of the LED located in the row with the highest Vf will come to 0.37V (ADIM=2.5V, ILED=100mA). As a result, the pin voltages of other LEDs become higher by Vf variation. After completion of soft start, the FB pin is put into the high-impedance state with the PWM signal being in the low state, thus maintaining the FB voltage.

○ **RT (18pin)**

The RT pin is used to connect a DC/DC frequency setting resistor. DC/DC drive frequency is determined by connecting the RT resistor.

**ODrive frequency vs. RT resistance (Ideal)**

$$R_{RT} = \frac{15000}{f_{SW} [kHz]} [k\Omega]$$

When RT is 100kΩ, Fsw is 150kHz(typ.). However, drive frequency setting should be made in the range of 100 kHz to 800 kHz.

○ **ADIM (19pin)**

ADIM pin is for analog dimming. Output current is proportionality with input voltage. Basically, ADIM pin assumes the voltage inputted externally using high accuracy of resistive divider and etc., IC internally is in OPEN (High impedance) condition. Cannot use in an OPEN condition. If you don't use analog dimming, please connect pull-up resistor to over 5V (for example REG58).

○ **VCC (20pin)**

The VCC pin is used to supply power for the IC in the range of 9 to 35V. If the VCC pin voltage reaches 7.5V (Typ.) or more, the IC will initiate operation. If it reaches 7.2V (Typ.) or less, the IC will be shut down.

**Startup operation and soft start (SS) capacitance setting**

The following section describes the sequence for the startup of this IC.

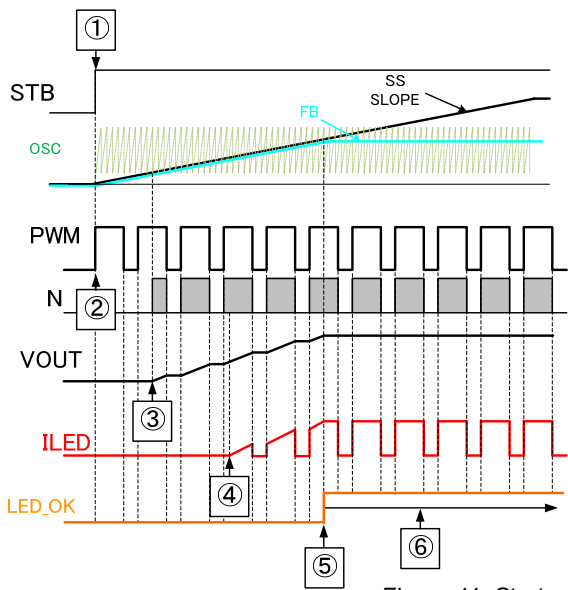

Figure 11. Startup waveform

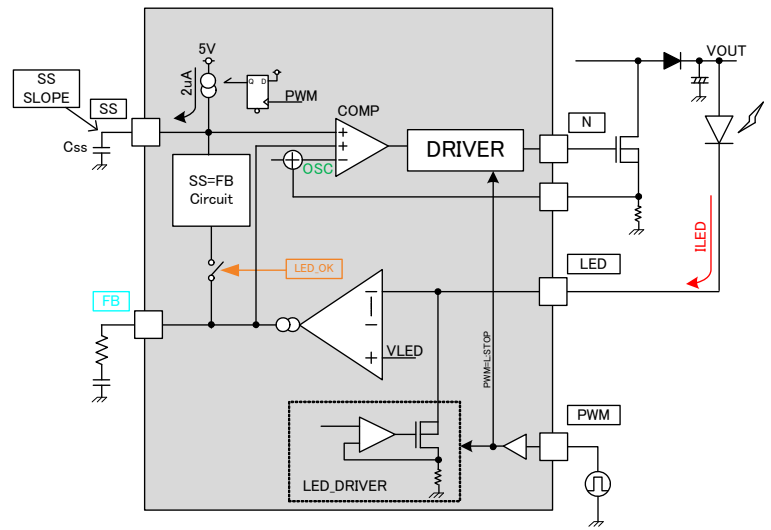

Figure 12. Circuit behavior at startup

**Description of startup sequence**

- (1) Set the STB and PWM pin to "ON".
- (2) Set all systems to "ON", SS charge will be initiated.  
At this time, a circuit in which SS pin voltage for soft start becomes equal to FB pin voltage operates to equalize the FB pin and SS pin voltages regardless of whether the PWM pin is set to Low or High level.
- (3) Since the FB pin and SS pin reach the lower limit of the internal sawtooth wave of the IC, the DC/DC converter operates to start VOUT voltage rising.
- (4) The Vout voltage continues rising to reach a voltage at which LED current starts flowing.
- (5) When the LED current reaches the set amount of current, isolate the FB circuit from the SS circuit. With this, the startup operation is completed.
- (6) After that, conduct normal operation following the feedback operation sequence with the LED pins.  
If the SS pin voltage reaches 3.7V or more, the LED protection function will be activated to forcedly end the SS and FB equalizing circuit.

**OSS capacitance setting procedure**

As aforementioned, this IC stops DC/DC converter when the PWM pin is set to Low level and conducts step-up operation only in the section in which the PWM pin is maintained at High level. Consequently, setting the PWM duty cycle to the minimum will extend the startup time. The startup time also varies with application settings of output capacitance, LED current, output voltage, and others.

Startup time at minimum duty cycle can be approximated according to the following method:

Make measurement of VOUT startup time with a 100% duty cycle, first. Take this value as "Trise100".

The startup time "Trise\_min" for the relevant application with the minimum duty cycle is given by the following equation.

$$T_{rise\_min} = \frac{T_{rise\_100}[Sec]}{Min\_Duty[ratio]} [Sec]$$

However, since this calculation method is just for approximation, use it only as a guide.

Make setting of time during which the SS pin voltage reaches the FB pin voltage longer than this startup time.

Assuming that the FB pin voltage is VFB, the time is given by the following equation:

$$T_{ss} = \frac{C_{ss}[F] \times V_{FB}[V]}{2[\mu A]} [Sec]$$

As a result, it is recommended to make SS capacitance setting so that "Tss" will be greater than "Trise\_min"

**○ About unused LED terminal automatic detecting function**

This IC is detected automatically that it is an unused channel by assuming the LED terminal to be OPEN at starting. It explains the sequence.

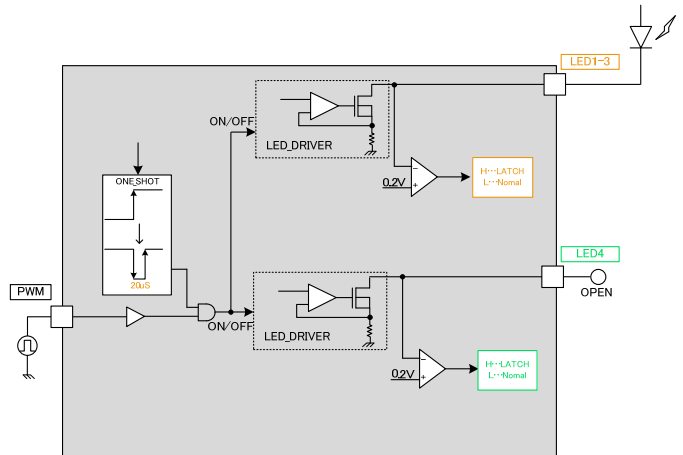
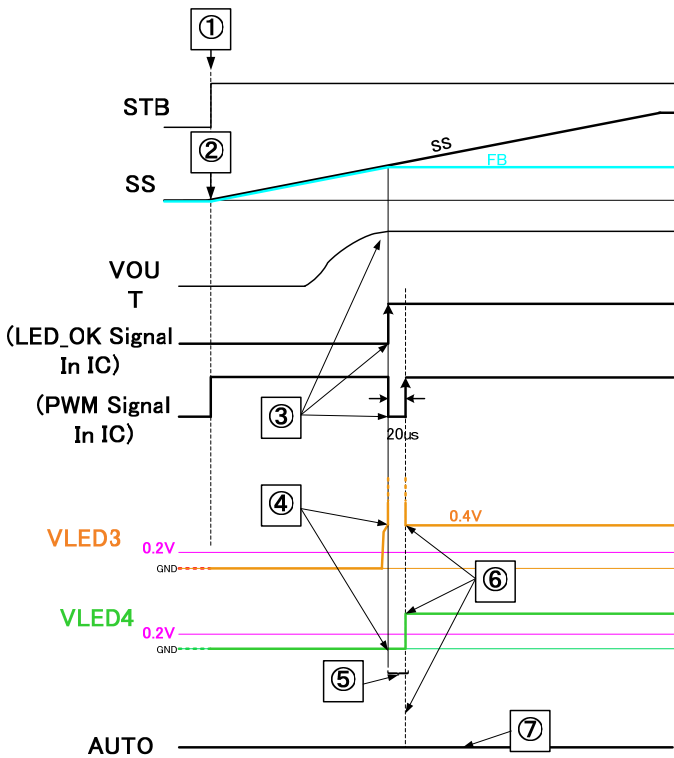

Figure 14. Block diagram

**Sequence;**

- ① STB=ON
- ② All systems are ON at initial timing of PWM=H. SS starts charging.
- ③ When the output voltage is boosted enough, and enough current flows through the LED, LED\_OK signal is switched in the IC. PWM=L from the Rise timing of this signal for about 20us
- ④ During this PWM=L period, LED pins with LED connections' output voltage becomes 0.2V and above, where as unused LED pins are below 0.2V.
- ⑤ During this time, determination on whether the LED pins are 0.2V above/below is done.
- ⑥ After the determination, unused LED pins are pulled up to 5V.
- ⑦ The AUTO signal remains "L" level.

In addition, automatic determination of the OPEN decision will only be in SS range, therefore, please set the application so that the step-up/boost be completed before SS > 3.7V.



**LED current setting**

Setting of LED output current "ILED" can be made by connecting a resistor R<sub>ISET</sub> to the ISET pin.

**ORISET vs. ILED current relation equation**

$$R_{ISET} = \frac{7500}{I_{LED} [mA]} \quad [k\Omega] \quad (\text{ADIM}=2.5V)$$

However, LED current setting should be made in the range of 30mA to 200mA.

**[Setting example]**

To set ILED current to 100mA, R<sub>ISET</sub> resistance is given by the following equation:

$$R_{ISET} = \frac{7500}{I_{LED} [mA]} = \frac{7500}{100 [mA]} = 75 \quad [k\Omega]$$

**DC/DC converter drive frequency setting**

DC/DC converter drive frequency is determined by making RT resistance setting.

**ODrive frequency vs. RT resistance (ideal) relation equation**

$$R_{RT} = \frac{15000}{f_{sw} [kHz]} \quad [k\Omega]$$

where fsw = DC/DC converter oscillation frequency [kHz]

This equation has become an ideal equation without any correction item included.

For accurate frequency settings, thorough verification should be performed on practical sets.

**[Setting example]**

To set DC/DC drive frequency "fsw" to 200 kHz, RRT is given by the following equation:

$$R_{RT} = \frac{15000}{f_{sw} [kHz]} = \frac{15000}{200 [kHz]} = 75 \quad [k\Omega]$$

**OVP/SCP Settings**

OVP pin is DC/DC output voltage's over voltage protection and short circuit protection input pin.  
 OVP pin is a high impedance pin with no pull down resistor. Thus, at OPEN state please set the voltage input settings using voltage dividing resistor and such.  
 Respective OVP pin protection conditions are as below

Protection Name	Detection Pin	Detection Condition	Cancellation Condition	Timer Operations	Protection Type
OVP	OVP	OVP>3.0V	OVP<2.9V	No	DCDC stops during detection
SCP	OVP	OVP<0.1V	OVP>0.1V	Yes	All latch

○**OVP Detection Setting**

VO<sub>UT</sub> abnormally increase, voltage detected by OVP, VO<sub>V<sub>DET</sub></sub>, R1,R2 settings are as follows

$$R1 = R2[k\Omega] \times \frac{(VOVP_{DET}[V] - 3.0[V])}{3.0[V]} \quad [k\Omega]$$

○**OVP Cancellation Setting**

R1,R2 set from above equation, OVP cancellation voltage VO<sub>V<sub>CAN</sub></sub> equals to

$$VOVP_{CAN} = 2.9V \times \frac{(R1[k\Omega] + R2[k\Omega])}{R2[k\Omega]} \quad [V]$$

○**SCP Detection Setting**

When R1,R2 are set using values obtained above, SCP voltage setting is V<sub>SCP<sub>DET</sub></sub> is as follows

$$VSCP_{DET} = 0.1V \times \frac{(R1[k\Omega] + R2[k\Omega])}{R2[k\Omega]} \quad [V]$$

**[Setting Example]**

VO<sub>UT</sub> at normal operation 56V, OVP detection voltage VO<sub>V<sub>DET</sub></sub>=68V, R2=10k, R1 is as follows

$$R1 = R2[k\Omega] \times \frac{(VOVP_{DET}[V] - 3.0[V])}{3.0[V]} = 10[k\Omega] \times \frac{(68[V] - 3[V])}{3[V]} = 216.7 \quad [k\Omega]$$

When R1, R2 are set at these values, OVP cancellation voltage, VO<sub>V<sub>CAN</sub></sub>

$$VOVP_{CAN} = 2.9[V] \times \frac{(R1[k\Omega] + R2[k\Omega])}{R2[k\Omega]} = 2.9[V] \times \frac{10[k\Omega] + 216.7[k\Omega]}{10[k\Omega]} [V] = 65.7 \quad [V]$$

In addition, at this R1, R2, SCP detection voltage

$$VSCP_{DET} = 0.1[V] \times \frac{(R1[k\Omega] + R2[k\Omega])}{R2[k\Omega]} = 0.1[V] \times \frac{10[k\Omega] + 216.7[k\Omega]}{10[k\Omega]} [V] = 2.27 \quad [V]$$

**To select DC/DC components, give consideration to IC variations as well as individual component variations, and then conduct thorough verification on practical systems.**

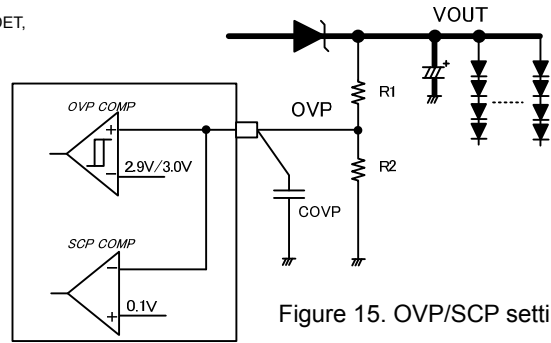

Figure 15. OVP/SCP setting example

**Timer Latch Time Setting**

This IC has a built-in timer latch counter. Timer latch time is set by counting the clock frequency which is set at the RT pin. After

**Timer Latch Time**

When various abnormal conditions happen, counting starts from the timing, latch occurs after below time has passed. Furthermore, even if PWM=L, if abnormal condition continues, timer count will not reset.

$$LATCH_{TIME} = 2^{12} \times \frac{R_{RT}}{1.5 \times 10^{10}} = 4096 \times \frac{R_{RT} [k\Omega]}{1.5 \times 10^7} [s]$$

Here,  $LATCH_{TIME}$  = time until latch condition occurs  
 $R_{RT}$  = Resistor value connected to RT pin

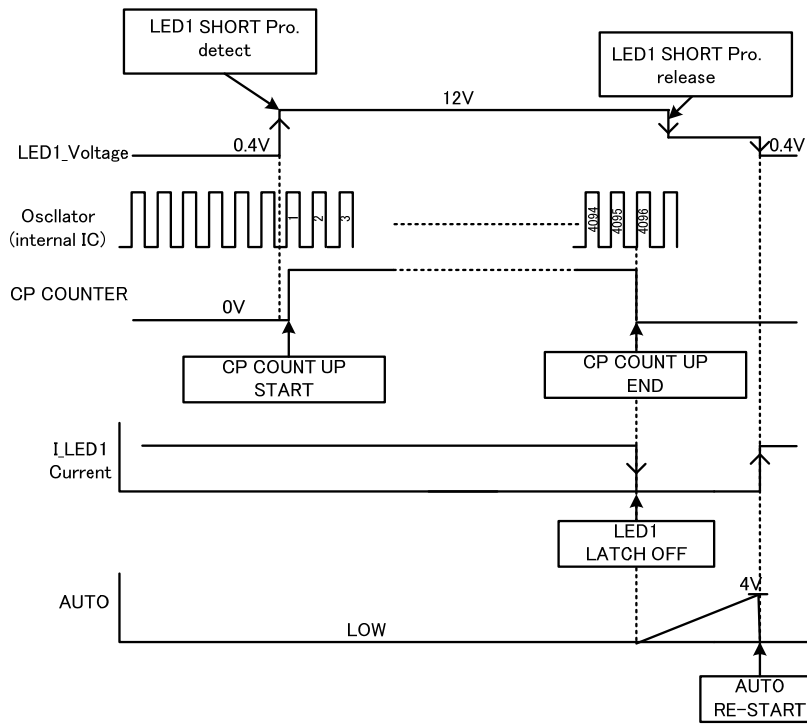

Figure 16. Example of LED Short protection timing chart

**【Setting Example】**

Timer latch time when  $R_T=75k\Omega$

$$LATCH_{TIME} = 4096 \times \frac{R_{RT} [k\Omega]}{1.5 \times 10^7} = 4096 \times \frac{75 [k\Omega]}{1.5 \times 10^7} = 0.02 [s]$$

**OCP Settings/DCDC Components' Current Capacity Selection Method**

One of the function of CS pin - when its pin voltage>0.45 it stops the DCDC. Thus, RCS resistor value need to be checked after the peak current flow through the inductor is calculated. Furthermore, DCDC external components' current capacity needs to be greater than peak current flowing through this inductor.

**(Inductor peak current Ipeak calculation method)**

Firstly, ripple voltage which occurs at the CS pin is decided depending on the DCDC application conditions.

The conditions when made as below;

Output voltage=VOUT[V]

LED total current=IOUT[A]

DCDC input voltage=VIN[V]

DCDC efficiency =η[%]

Total required average input current IIN:

$$I_{IN} = \frac{V_{OUT}[V] \times I_{OUT}[A]}{V_{IN}[V] \times \eta[\%]} \quad [A]$$

Inductor ripple current IL[A] which occurs at inductor L[H] during DCDC drive operation with switching frequency=fsw[Hz] is as follows

$$\Delta IL = \frac{(V_{OUT}[V] - V_{IN}[V]) \times V_{IN}[V]}{L[H] \times V_{OUT}[V] \times f_{sw}[Hz]} \quad [A]$$

Therefore, IL's peak current Ipeak can be calculated using below equation

$$I_{peak} = I_{IN}[A] + \frac{\Delta IL[A]}{2} \quad [A] \dots (1)$$

**(Resistor RCS connected to CS pin selection method)**

This Ipeak flows in RCS and generates voltage. (refer to time chart diagram on the right). This voltage value, VCSpeak can be calculated as below

$$VCS_{peak} = Rcs \times I_{peak} \quad [V]$$

This VCSpeak when reach 0.45V, will stop the DCDC output. Thus when selecting RCS value, below condition needs to be met.

$$Rcs[\Omega] \times I_{peak}[A] < 0.45[V]$$

**(DCDC Components' Current Capacity Selection Method)**

When OCP reach detection voltage CS=0.45V, Iocp current

$$I_{OCP} = \frac{0.45[V]}{Rcs[\Omega]} \quad [A] \dots (2)$$

Ipeak current (1), IOCP current (2), and components' MAX current capacity needs to satisfy the following

$$I_{peak} < I_{OCP} < \text{Rated current of components}$$

Above condition needs to be satisfied when selecting DCDC application parts eg. FET, inductor, diode etc. Furthermore, continuous mode is recommended for normal DCDC applications. Inductor's ripple current MIN limit value, Imin becoming

$$I_{min} = I_{IN}[A] - \frac{\Delta IL[A]}{2} [A] > 0$$

Is a condition to be met. If this is not met, it is called discontinuous mode.

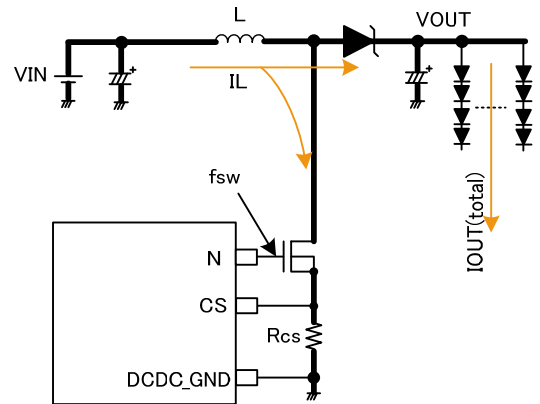

Figure 17. DC/DC converter application circuit

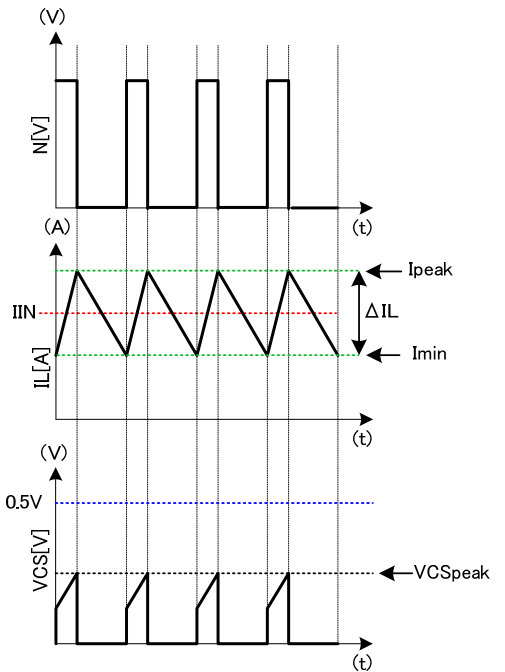

Figure 18. Inductor current waveform

**【Setting Example】**

Output voltage=V<sub>OUT</sub>[V]=56V  
 LED total current=I<sub>OUT</sub>[A]=100mA×4ch=0.40A  
 DCDC input voltage=V<sub>IN</sub>[V]=14V  
 DCDC efficiency=η[%]=90%  
 Total required average input current I<sub>IN</sub>:

$$I_{IN}[A] = \frac{V_{OUT}[V] \times I_{OUT}[A]}{V_{IN}[V] \times \eta[\%]} = \frac{56[V] \times 0.40[A]}{14[V] \times 90[\%]} = 1.78 [A]$$

When, DCDC switching frequency =f<sub>sw</sub>[Hz]=200kHz  
 Inductor L[H]=33uH,  
 Inductor ripple current ΔIL[A]:

$$\Delta IL = \frac{(V_{OUT}[V] - V_{IN}[V]) \times V_{IN}[V]}{L[H] \times V_{OUT}[V] \times f_{sw}[Hz]} = \frac{(56[V] - 14[V]) \times 14[V]}{33 \times 10^{-6}[H] \times 56[V] \times 200 \times 10^3[Hz]} = 1.59 [A]$$

Thus, IL peak current I<sub>peak</sub> becomes

$$I_{peak} = I_{IN}[A] + \frac{\Delta IL[A]}{2} [A] = 1.78[A] + \frac{1.59[A]}{2} = 2.58 [A] \quad \dots\text{Peak current calculation result}$$

RCS resistor value when set at 0.1ohm

$$VCS_{peak} = Rcs \times I_{peak} = 0.10[\Omega] \times 2.58[A] = 0.258 [V] < 0.45V \quad \dots\text{RCS resistor consideration}$$

and satisfy the condition.

In addition, OCP detection current I<sub>OCP</sub> at this time is

$$I_{OCP} = \frac{0.45[V]}{0.1[\Omega]} = 4.5 [A]$$

If parts used (FET,INDUCTOR, DIODE etc)'s current capacity<5A,

$$I_{peak} < I_{OCP} < \text{Rated current of components} = 2.58[A] < 4.5[A] < 5[A]$$

...DCDC current capacity consideration

Thus, there is no problem of parts selection as the above condition is satisfied.

In addition, IL ripple current minimum limit I<sub>min</sub> is

$$I_{min} = I_{IN}[A] - \frac{\Delta IL[A]}{2} [A] = 1.78[A] - 0.795[A] = 0.985[A] > 0$$

Thus, will not become discontinuous mode.

**To select DC/DC components, give consideration to IC variations as well as individual component variations, and then conduct thorough verification on practical systems.**



**Selection of inductor L**

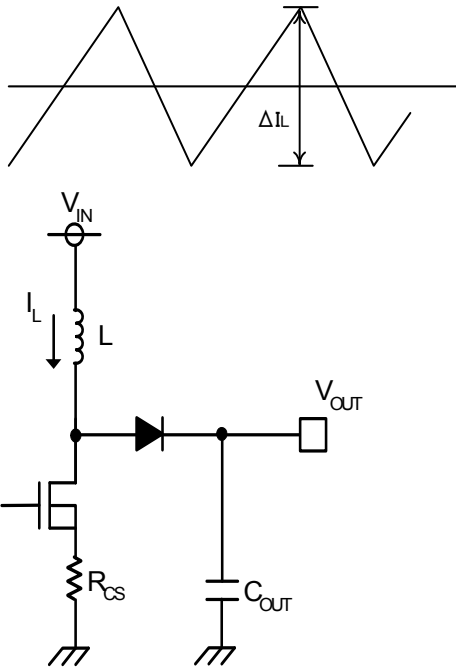

The value of inductor has significant influence on the input ripple current. As shown by Equation (1), the larger the inductor and the higher the switching frequency, the inductor ripple current  $\Delta IL$  becomes increasingly lower.

$$\Delta IL = \frac{(V_{OUT} - V_{IN}) \times V_{IN}}{L \times V_{OUT} \times f_{SW}} [A] \quad \dots \dots (1)$$

Expressing efficiency as shown by Equation (2), peak input current is given as Equation (3).

$$\eta = \frac{V_{OUT} \times I_{OUT}}{V_{IN} \times I_{IN}} \quad \dots \dots (2)$$

$$I_{LMAX} = I_{IN} + \frac{\Delta IL}{2} = \frac{V_{OUT} \times I_{OUT}}{V_{IN} \times \eta} + \frac{\Delta IL}{2} \quad \dots \dots (3)$$

where, L: Reactance value [H],  
 $V_{OUT}$ : DC/DC output voltage [V],  
 $V_{IN}$ : Input voltage [V],  
 $I_{OUT}$ : Output load current (total output current) [A],  
 $I_{IN}$ : Input current [A], and  
 $f_{SW}$ : Oscillation frequency [Hz]

Figure 19. Inductor current waveform and diagram

Note: If a current in excess of the rated current of the inductor applies to the coil, the inductor will cause magnetic saturation, resulting in efficiency degradation.

Select an inductor with an adequate margin so that peak current will not exceed the rated current of the inductor.

Note: To reduce power dissipation from and increase efficiency of inductor, select an inductor with low resistance component (DCR or ACR).

**Selection of output capacitor COUT**

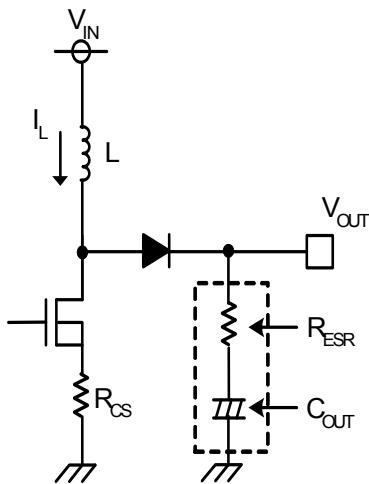

Select a capacitor on the output side taking into account the stability region of output voltage and equivalent series resistance necessary to smooth ripple voltage. Note that higher output ripple voltage may result in a drop in LED pin voltage, making it impossible to supply set LED current.

The output ripple voltage  $\Delta V_{OUT}$  is given by Equation (4).

$$\Delta V_{OUT} = I_{LMAX} \times R_{ESR} + \frac{1}{C_{OUT}} \times \frac{I_{OUT}}{\eta} \times \frac{1}{f_{SW}} [V] \quad \dots \dots (4)$$

where  $R_{ESR}$  = Equivalent series resistance of  $C_{OUT}$ .

Note: Select capacitor ratings with an adequate margin for output voltage.

Note: To use an electrolytic capacitor, an adequate margin should be provided for permissible current. Particularly to apply PWM light modulation to LED, note that a current higher than the set LED current transiently flows.

Figure 20. Output capacitor diagram,

**Selection of switching MOSFET transistors**

There will be no problem for switching MOSFET transistors having absolute maximum rating higher than rated current of the inductor L and VF higher than “ $C_{OUT}$  breakdown voltage + Rectifier diode”. However, to achieve high-speed switching, select transistors with small gate capacity (injected charge amount).

Note: Rated current larger than over current protection setting current is recommended.

Note: Selecting transistors with low on resistance can obtain high efficiency.

**Selection of rectifier diodes**

Select Schottky barrier diodes having current capability higher than the rated current of the inductor L and inverse breakdown voltage higher than  $C_{OUT}$  breakdown voltage, particularly having low forward voltage VF.

### Phase Compensation Setting Procedure

DC/DC converter application for current mode control includes one each of pole  $f_p$  (phase delay) by CR filter consisting of output capacitor and output resistor (i.e., LED current) and zero (phase lead)  $f_z$  by the output capacitor and capacitor ESR. Furthermore, the step-up DC/DC converter includes RHP zero " $f_{ZRHP}$ " as the second zero. Since the RHP zero has phase delay ( $-90^\circ$ ) characteristics like the pole, the crossover frequency  $f_c$  should be set to not more than RHP zero

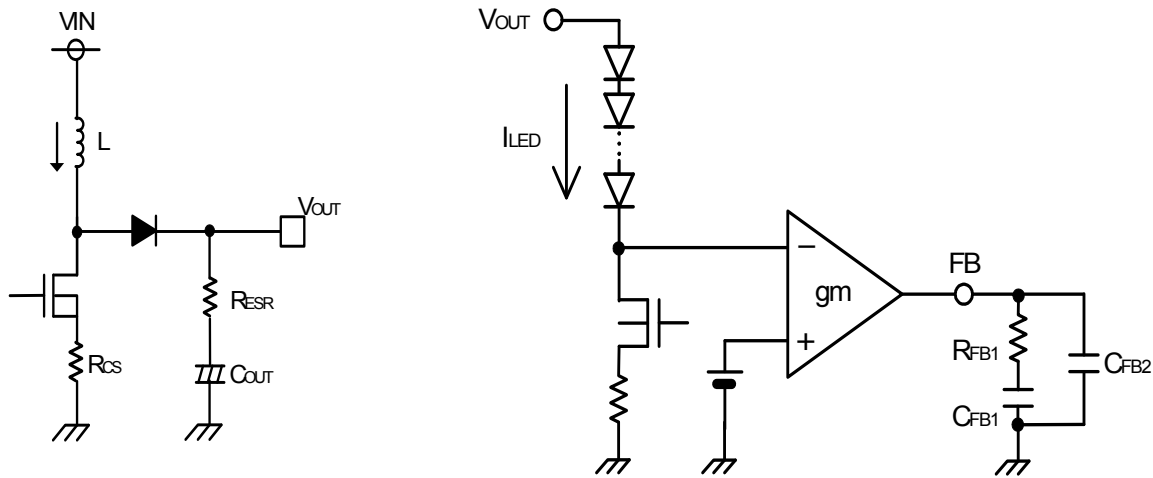

Figure 21. Output stage and error amplifier diagram

- i. Find pole  $f_p$  and RHP zero  $f_{ZRHP}$  of DC/DC converter.

$$f_p = \frac{I_{LED}}{2\pi \times V_{OUT} \times C_{OUT}} [Hz] \quad f_{ZRHP} = \frac{V_{OUT} \times (1-D)^2}{2\pi \times L \times I_{LED}} [Hz]$$

Where  $I_{LED}$  = Total LED current [A],  $D = \frac{V_{OUT} - V_{IN}}{V_{OUT}}$

- ii. Find phase compensation to be inserted in the error amplifier. (Set  $f_c$  to 1/5 of  $f_{ZRHP}$ .)

$$R_{FB1} = \frac{f_{RHZP} \times R_{CS} \times I_{LED}}{5 \times f_p \times gm \times V_{OUT} \times (1-D)} [\Omega]$$

$$C_{FB1} = \frac{1}{2\pi \times R_{FB1} \times f_c} = \frac{5}{2\pi \times R_{FB1} \times f_{ZRHP}} [F]$$

where  $gm = 4.0 \times 10^{-4} [S]$

- iii. Find zero used to compensate ESR ( $R_{ESR}$ ) of  $C_{OUT}$  (electrolytic capacitor).

$$C_{FB2} = \frac{R_{ESR} \times C_{OUT}}{R_{FB1}} [F]$$

Note: Even if a ceramic capacitor ( $R_{ESR}$  of the order of milliohms) for  $C_{OUT}$ , it is recommended to insert  $C_{FB2}$  for stable operation.

To improve transient response, it is necessary to increase  $R_{FB1}$  and reduce  $C_{FB1}$ . However, this improvement reduces a phase margin. To avoid this problem, conduct thorough verification, including variations in external components, on practical systems.

Timing Chart

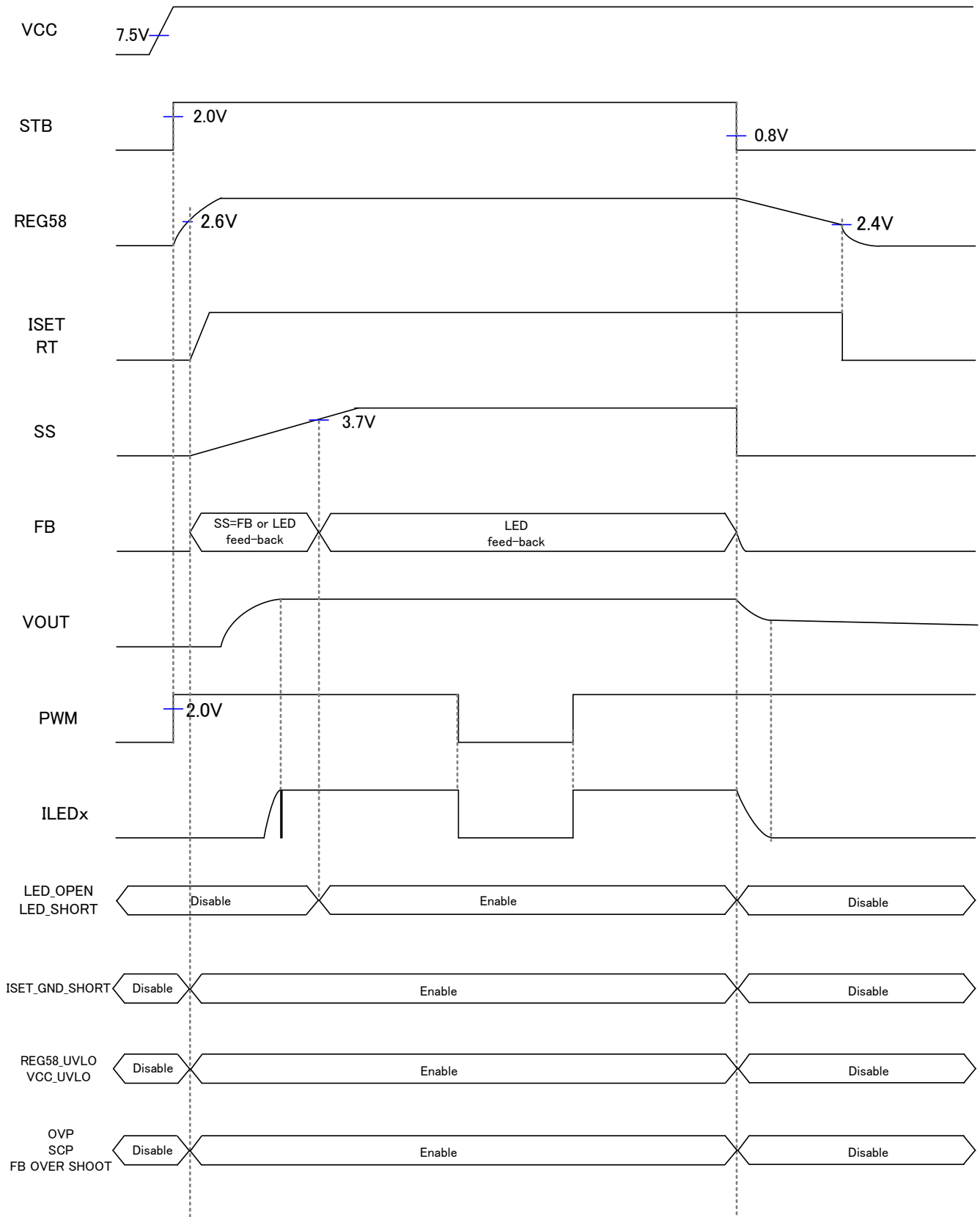

Figure 22. Timing chart

## List of Protect Function (typ condition)

Protection Name	Detection Pin	Detection Conditions			Cancellation Conditions	Protection Type
		Detection pin	PWM	SS		
LED OPEN	LEDx	LEDx < 0.2V	H	SS>3.7V	LEDx > 0.2V	Immediately Auto-Restart after detection (Judge periodically whether normal or not)
LEDSHORT	LEDx	LEDx > 5V	H	SS>3.7V	LEDx < 5V	Immediately Auto-Restart after detection (Judge periodically whether normal or not)
ISET GND SHORT	ISET	Under ISET×90%	-	-	Above ISET×90%	Auto-Restart
REG58 UVLO	REG58	REG58<2.4V	-	-	REG58>2.6V	Auto-Restart
VCC UVLO	VCC	VCC<7.3V	-	-	VCC>7.5V	Auto-Restart
OVP	OVP	OVP>3.0V	-	-	OVP<2.9V	Auto-Restart
SCP	OVP	OVP<0.1V	-	-	OVP>0.1V	Immediately Auto-Restart after detection (Judge periodically whether normal or not)
FB OVER SHOOT	FB	FB>4V	-	-	FB<3.6V	Immediately Auto-Restart after detection (Judge periodically whether normal or not)
OCP	CS	OCP>0.45V	-	-	-	Pulse-by-Pulse

To clear the latch type, STB should be set to "L" once, and then to "H".

Protection Function	Operation after the protection function detected		
	DC/DC	LED Driver	Soft-start
LED OPEN	Continue to operate	Only detects LED, stops after CP1 count	Continue to operate
LEDSHORT	Continue to operate	Only detects LED, stops after CP1 count	Continue to operate
ISET GND SHORT	Stop immediately	Stop immediately	Continue to operate
STB	Stop immediately	Stop (and when REG58<2.4V)	Discharge immediately
REG58 UVLO	Stop immediately	Stop immediately	Discharge immediately
VCC UVLO	Stop immediately	Stop immediately	Discharge immediately
OVP	Stop immediately (N pin only)	Continue to operate	Continue to operate
SCP	Stop immediately (N pin only)	Stop after CP1 count	Discharge after CP1 count
FB OVER SHOOT	Stop after CP2 count	Stop after CP2 count	Continue to operate
OCP	N pin limits DUTY	Continue to operate	Continue to operate

\* CP1 = 20ms (RT=75KΩ) , CP2=1.31s (RT=75KΩ)

## Operational Notes

### 1. Reverse Connection of Power Supply

Connecting the power supply in reverse polarity can damage the IC. Take precautions against reverse polarity when connecting the power supply, such as mounting an external diode between the power supply and the IC's power supply terminals.

### 2. Power Supply Lines

Design the PCB layout pattern to provide low impedance supply lines. Separate the ground and supply lines of the digital and analog blocks to prevent noise in the ground and supply lines of the digital block from affecting the analog block. Furthermore, connect a capacitor to ground at all power supply pins. Consider the effect of temperature and aging on the capacitance value when using electrolytic capacitors.

### 3. Ground Voltage

Ensure that no pins are at a voltage below that of the ground pin at any time, even during transient condition.

### 4. Ground Wiring Pattern

When using both small-signal and large-current ground traces, the two ground traces should be routed separately but connected to a single ground at the reference point of the application board to avoid fluctuations in the small-signal ground caused by large currents. Also ensure that the ground traces of external components do not cause variations on the ground voltage. The ground lines must be as short and thick as possible to reduce line impedance.

### 5. Thermal Consideration

Should by any chance the power dissipation rating be exceeded the rise in temperature of the chip may result in deterioration of the properties of the chip. The absolute maximum rating of the Pd stated in this specification is when the IC is mounted on a 70mm x 70mm x 1.6mm glass epoxy board. In case of exceeding this absolute maximum rating, increase the board size and copper area to prevent exceeding the Pd rating.

### 6. Recommended Operating Conditions

These conditions represent a range within which the expected characteristics of the IC can be approximately obtained. The electrical characteristics are guaranteed under the conditions of each parameter.

### 7. Rush Current

When power is first supplied to the IC, it is possible that the internal logic may be unstable and inrush current may flow instantaneously due to the internal powering sequence and delays, especially if the IC has more than one power supply. Therefore, give special consideration to power coupling capacitance, power wiring, width of ground wiring, and routing of connections.

### 8. Testing on Application Boards

When testing the IC on an application board, connecting a capacitor directly to a low-impedance output pin may subject the IC to stress. Always discharge capacitors completely after each process or step. The IC's power supply should always be turned off completely before connecting or removing it from the test setup during the inspection process. To prevent damage from static discharge, ground the IC during assembly and use similar precautions during transport and storage.

### 9. Inter-pin Short and Mounting Errors

Ensure that the direction and position are correct when mounting the IC on the PCB. Incorrect mounting may result in damaging the IC. Avoid nearby pins being shorted to each other especially to ground, power supply and output pin. Inter-pin shorts could be due to many reasons such as metal particles, water droplets (in very humid environment) and unintentional solder bridge deposited in between pins during assembly to name a few.



## Operational Notes – continued

**10. Unused Input Terminals**

Input terminals of an IC are often connected to the gate of a MOS transistor. The gate has extremely high impedance and extremely low capacitance. If left unconnected, the electric field from the outside can easily charge it. The small charge acquired in this way is enough to produce a significant effect on the conduction through the transistor and cause unexpected operation of the IC. So unless otherwise specified, unused input terminals should be connected to the power supply or ground line.

**11. Regarding the Input Pin of the IC**

This monolithic IC contains P+ isolation and P substrate layers between adjacent elements in order to keep them isolated. P-N junctions are formed at the intersection of the P layers with the N layers of other elements, creating a parasitic diode or transistor. For example (refer to figure below):

When  $GND > Pin A$  and  $GND > Pin B$ , the P-N junction operates as a parasitic diode.

When  $GND > Pin B$ , the P-N junction operates as a parasitic transistor.

Parasitic diodes inevitably occur in the structure of the IC. The operation of parasitic diodes can result in mutual interference among circuits, operational faults, or physical damage. Therefore, conditions that cause these diodes to operate, such as applying a voltage lower than the GND voltage to an input pin (and thus to the P substrate) should be avoided.

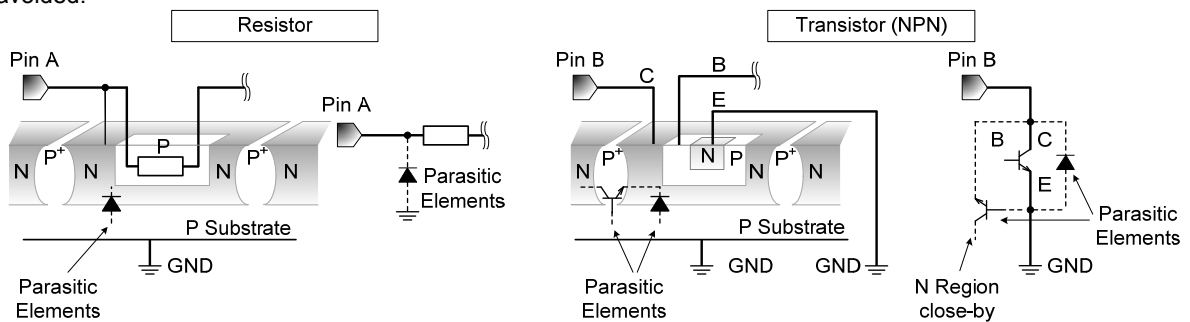

Figure 23. Example of monolithic IC structure

**12. Ceramic Capacitor**

When using a ceramic capacitor, determine the dielectric constant considering the change of capacitance with temperature and the decrease in nominal capacitance due to DC bias and others.

**13. Area of Safe Operation (ASO)**

Operate the IC such that the output voltage, output current, and power dissipation are all within the Area of Safe Operation (ASO).

**14. Thermal Shutdown Circuit(TSD)**

This IC has a built-in thermal shutdown circuit that prevents heat damage to the IC. Normal operation should always be within the IC's power dissipation rating. If however the rating is exceeded for a continued period, the junction temperature ( $T_j$ ) will rise which will activate the TSD circuit that will turn OFF all output pins. When the  $T_j$  falls below the TSD threshold, the circuits are automatically restored to normal operation.

Note that the TSD circuit operates in a situation that exceeds the absolute maximum ratings and therefore, under no circumstances, should the TSD circuit be used in a set design or for any purpose other than protecting the IC from heat damage.

**15. Over Current Protection Circuit (OCP)**

This IC incorporates an integrated overcurrent protection circuit that is activated when the load is shorted. This protection circuit is effective in preventing damage due to sudden and unexpected incidents. However, the IC should not be used in applications characterized by continuous operation or transitioning of the protection circuit.

Ordering Information

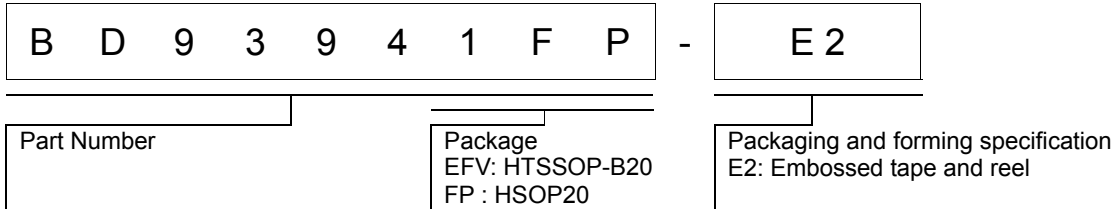

Marking Diagrams

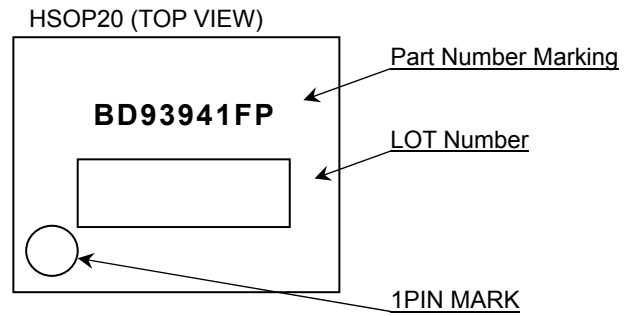
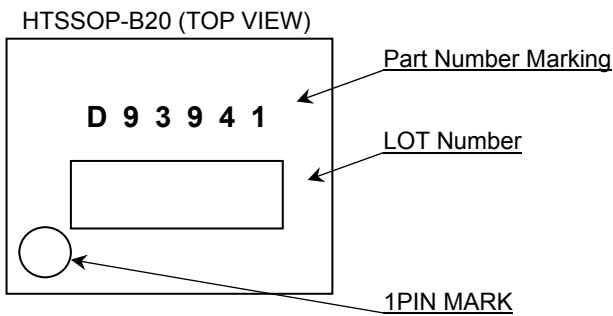

Physical Dimension, Tape and Reel Information 1

Package Name	HTSSOP-B20
--------------	------------

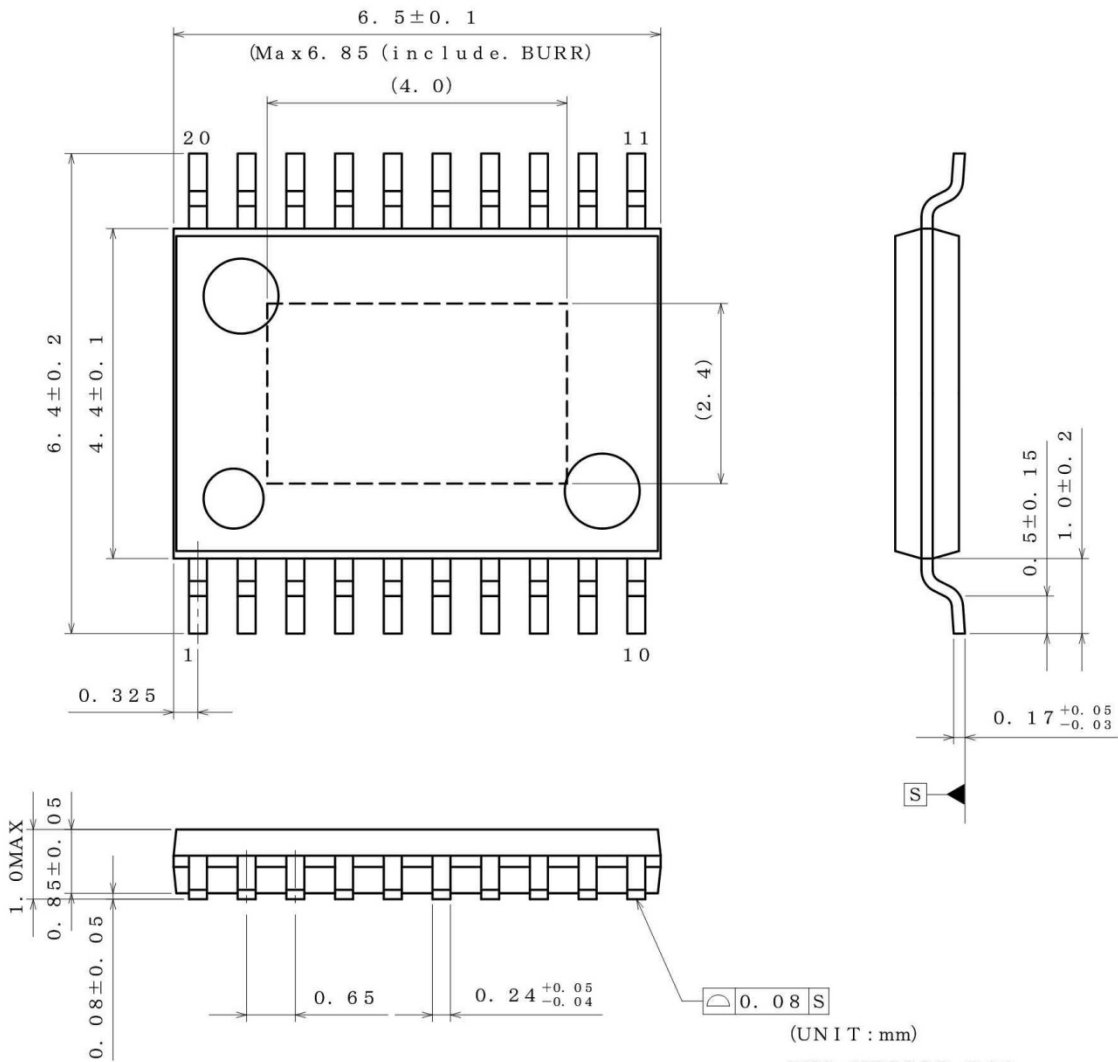

(UNIT : mm)  
 PKG : HTSSOP-B20  
 Drawing No. EX192-5002

