



Chipsmall Limited consists of a professional team with an average of over 10 year of expertise in the distribution of electronic components. Based in Hongkong, we have already established firm and mutual-benefit business relationships with customers from,Europe,America and south Asia,supplying obsolete and hard-to-find components to meet their specific needs.

With the principle of “Quality Parts,Customers Priority,Honest Operation,and Considerate Service”,our business mainly focus on the distribution of electronic components. Line cards we deal with include Microchip,ALPS,ROHM,Xilinx,Pulse,ON,Everlight and Freescale. Main products comprise IC,Modules,Potentiometer,IC Socket,Relay,Connector.Our parts cover such applications as commercial,industrial, and automotives areas.

We are looking forward to setting up business relationship with you and hope to provide you with the best service and solution. Let us make a better world for our industry!



Contact us

Tel: +86-755-8981 8866 Fax: +86-755-8427 6832

Email & Skype: info@chipsmall.com Web: www.chipsmall.com

Address: A1208, Overseas Decoration Building, #122 Zhenhua RD., Futian, Shenzhen, China



Application

NOTES:

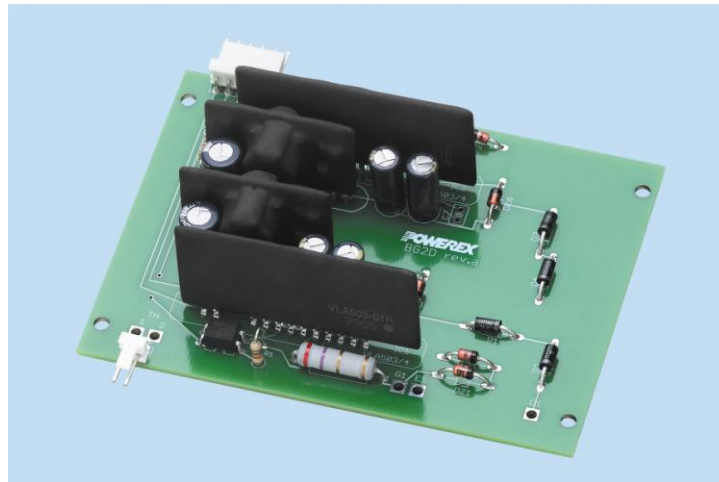

BG2D – Solderless Connection Gate Drive Prototype Board

Description: The BG2D is a two channel gate drive circuit for that the dual NX series modules' pins plug into directly. The BG2D utilizes Powerex hybrid gate drivers and DC to DC converters to provide efficient switching of modules rated up to 450A. The hybrid gate drivers include high speed opto-couplers for control signal isolation and desaturation detection to protect the IGBT from short circuit conditions. The hybrid DC to DC converters provide fully isolated control power for each driving channel. The BG2D also provides an isolated fault feedback signal.

Features:

- 1.5A, 3A or 5A Peak Output Current
- 2500VRMS isolation for control power and signals
- Standard AMP MTA .100" input connector
- Operates from a single 15 VDC or 24 VDC supply
- Wide output voltage swing +15V/-8V
- Compact Size 3" x 2.2" (76mm x 56mm)

Applications:

BG2D is designed for use with Powerex NX series IGBT modules.

- Use [VLA106-15242](#) DC to DC converter for operation with 15 VDC control power
- Use [VLA106-24242](#) DC to DC converter for operation with 24 VDC control power

Ordering Information: **BG2D-1515** is a kit with a bare BG2B board, two M57159L-01 and two VLA106-15242
BG2D-3015 is a kit with a bare BG2B board, two VLA504-01 and two VLA106-15242
BG2D-5015 is a kit with a bare BG2B board, two VLA503-01 and two VLA106-15242
BG2D is a bare PCB only

BG2D Application Guide

Gate Driver Part Number	Peak Drive Current (I_{OP})	Minimum R_G	Typical Application* (IGBT Module Rating)	DC/DC Converter
M57159L-01	+/- 1.5A	4.2 Ω	Up to 100A	VLA106-15242 for 15 VDC input
VLA504-01	+/- 3A	3.0 Ω	Up to 200A	
VLA503-01	+/- 5A	2.0 Ω	Up to 400A	VLA106-24242 for 24 VDC input

* Compatible IGBT module depends on voltage rating, switching frequency and selected R_G . Refer to Powerex application notes for details.

Note: VLA504-01 and VLA503-01 gate drivers replace older types M5759L and M5796L. VLA106-15242 replaces the older M57145L-01

**Figure 1: VLA503-01/VLA504-01/M57159L-01
Block Diagram**

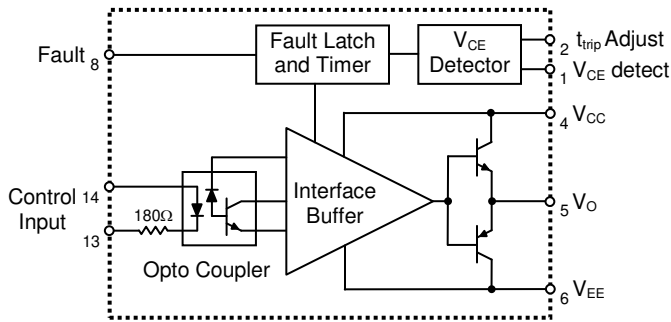

**Figure 2: VLA106-15242, VLA106-24242
Block Diagram**

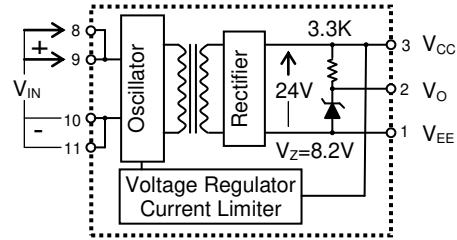

Circuit Explanation: The BG2D is a basic two channel gate driver designed around the recommended application circuits for the Powerex M57159L-01, VLA503-01 and VLA504-01 hybrid IGBT gate drivers in combination with either VLA106-15242 or VLA106-24242 isolated DC to DC converters.

A functional block diagram of the VLA503/504-01 and M57159L-01 hybrid gate drivers is shown for reference in Figure 1. These gate drivers are optimized for use with Powerex NX, NF and A series IGBT modules. The drivers use a high speed open collector type opto-coupler to provide 2500VRMS isolation of control signals. The output stage is designed to provide high current gate drive with the appropriate on- and off-state bias voltages for large IGBT modules. The gate driver includes a desaturation detection circuit to provide protection against short circuit conditions. For additional detailed information on the characteristics and operation of these gate drivers please refer to the individual device data sheets.

Figure 2 shows a block diagram of the VLA106-15242 and VLA106-24242 hybrid DC to DC converters. These two devices are identical except that VLA106-15242 is designed to operate from a 15 VDC input and the VLA106-24242 is designed to operate from a 24 VDC input. These DC to DC converters use a transformer to provide 2500VRMS isolation for gate drive power. The converter's regulated 24VDC output is split using a resistor and zener diode to provide +15.8V and -8.2V for the hybrid gate driver. For additional detailed information on the operation of the hybrid gate drivers and DC to DC converters please see the individual device data sheets.

A complete schematic and component selection guide for the BG2D is shown in Figure 3. The board will normally be operated with two input voltage sources. A 5V logic source (+V_L) provides drive for the high speed opto-couplers inside the hybrid gate drivers and pull-up voltage for the fault signal isolation optos OP1 and OP2. A control power supply (+V_S) provides power for the gate driver and is connected to the primary side of the DC to DC converters at pins 8,9 and 10,11. The +V_S source is decoupled with the low impedance electrolytic capacitors C4 and C8. These capacitors are connected close to the input pins of each DC to DC converter to provide a stable, well-filtered DC source. A 150uF capacitor was selected for C4 and C8 to provide the required ripple current and filtering assuming a maximum driving load and a significant distance to the main filter capacitor of the +V_S supply. These capacitors will be larger than necessary if the driving load is smaller or the V_S supply main filter capacitors are nearby. The DC to DC converters provide isolated gate drive power which consists of +15.8V (V_{CC}) at pin 3 and -8.2 (V_{EE}) at pin 1 with respect to common at pin 2. The gate drive power supplies are decoupled using the low impedance electrolytic capacitors C1, C2, C5, and C6. It is very important that these capacitors have low enough impedance and sufficient ripple current capability to provide the required high current gate drive pulses. The 82uF low impedance capacitors used on the BG2D are sized to supply 5A gate pulses at a 10KHz rate. If the application is operating at lower frequency or lower peak current it may be possible to reduce the size of these capacitors.

The isolated V_{EE} and V_{CC} supplies provided by the DC to DC converters are connected to the hybrid gate drivers at pins 4 and 6 to provide gate drive power. The hybrid gate driver amplifies the control input signal and produces high current gate drive at pin 5. The gate drive current is adjusted by selecting the appropriate series gate resistance (R_G). R_G will normally be adjusted to provide suitable drive for the module being used considering dynamic performance, losses and switching noise. For more information on selecting R_G see Powerex IGBT module application notes. Protection against gate voltage surges is provided by DZ1, DZ2, DZ4, and DZ5. These zener diodes also help to control short circuit currents by shunting miller current away from the gate.

Short circuit protection is provided by means of desaturation detection. For details on the operation of this circuit consult the hybrid gate driver individual data sheets. The collector voltage of each IGBT is detected through the series connected high voltage blocking diodes D1, D2 and D3, D4. The combined blocking voltage of the series connected diodes must be equal to or greater than the V_{CES} rating of the IGBT. For applications using lower voltage IGBT modules it is possible to use a single detection diode in each channel. DZ3 and DZ6 protect the gate driver's detect input (Pin 1) from voltage surges during reverse recovery of the high voltage blocking diodes. The capacitors C3 and C7 are used to adjust the drivers protection circuit trip time. The driver's default settings are sufficient for many applications so it may be possible to omit these capacitors. For details on the use of C3 and C7 consult the individual gate driver data sheets.

Figure 3: BG2D Schematic and Component Selection

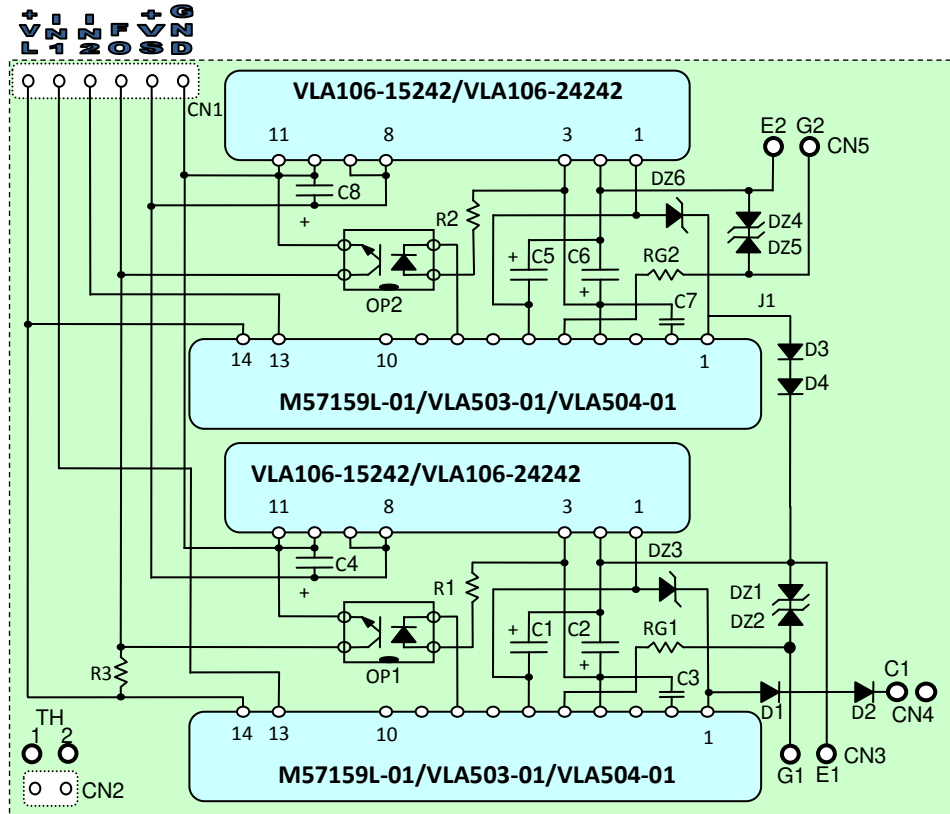

Component Selection:

Designation	Typical Value	Description	Example: Mfg./PN
D1, D2, D3, D4	0.5 A, 1000V	V_{CE} detection diode – ultra fast recovery	ON Semi MUR1100E
DZ1, DZ2, DZ4, DZ5	16V, 1W	Gate Voltage Surge Protection	1N4745
DZ3, DZ6	30V, 1W	Detect input pin surge voltage protection	1N4751
C1, C2, C5, C6	82 μ F, 35V	Power supply filter – Electrolytic, low Impedance	Panasonic EEU-FC1V820
C4, C8	150 μ F, 35V	Control power filter – Electrolytic, low impedance	Panasonic EEU-FC1V151
C3, C7*	0-200 pF	Adj. Trip time – Multilayer ceramic or film*	EPCOS B37979-----
R1, R2	4.7k Ω , 0.25W	Fault sink current limiting resistor	
R3	4.7k Ω , 0.25W	Fault feedback pull-up resistor	
OP1, OP2	NEC PS2501	Opto-coupler for fault signal isolation	NEC PS2501
CN1**	MTA .100"	Input and gate drive connectors	AMP 640457-6
CN2	MTA .100"	NTC Thermistor Connection	AMP 640457-2
TH, CN3, CN4, CN5	3.81mm	Two Pin Power Module Socket	Honda Connectors PZAB-2SFY+

* Not required in all applications. Please see hybrid gate driver application notes for details.

If the gate driver's short circuit protection is activated it immediately shuts down the gate drive and pulls pin 8 low to indicate a fault. Current flows from Vcc (pin 3 of DC to DC converter) through the LED in fault isolation opto (OP1, OP2) to pin 8. The transistor in the fault isolation opto turns on and pulls the fault signal line (FO) at pin 4 of CN1 low. This opto isolated signal can now be used by the controller to detect the fault condition.

Figure 4: BG2D External Wiring Diagram

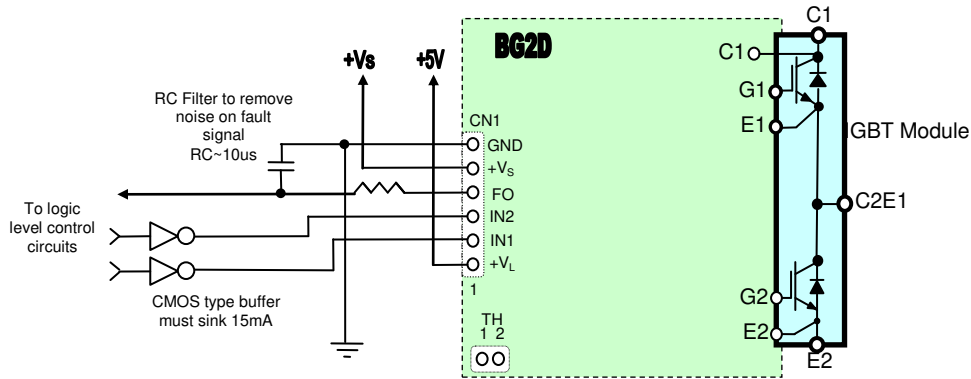

Interface Circuit Requirements: A typical interface circuit for the BG2D is shown in Figure 4. A single control power supply (+V_S) is connected to pin 5 of CN1 with its common at pin 6. This supply provides all of the gate drive power for both channels via the hybrid DC to DC converters. The current drawn from the +V_S supply will vary from less than 100mA to more than 500mA depending on the switching frequency and size of IGBT being driven. Consult the hybrid gate driver application notes for details on determining the required supply current for the gate driver. The gate driver supply current can then be converted into current drawn from the +V_S supply using the efficiency specification on the DC to DC converter data sheet.

A 5V logic supply is connected at pin 1 of CN1 and shares the same common at pin 6 of CN1 as the 15V control supply. The 5V supply is directly connected to pin 14 of the hybrid gate driver which is internally connected to the anode of the LED in the high speed opto coupler. The 5V supply is also used to pull the output side of the fault isolation opto couplers high.

The control signal interface is designed for use with standard 5V CMOS logic. The control input signals at pins 2 and 3 of connector CN1 are used to turn the IGBTs on and off. These signals are active low which means that the gate driver output will be high (IGBT on) when they are pulled low. These control pins are connected directly to pin 13 of the hybrid gate driver which is connected internally through a 180Ω limiting resistor to the cathode of the LED in the high speed opto coupler (see figure 1). When the control signal is pulled low, current flows from the 5V logic supply through the LED to turn the gate driver's output on. The control pins must be pulled low with a buffer that is capable of sinking at least 16mA in order to turn on the high speed opto coupler inside the hybrid gate driver. A CMOS buffer that actively pulls its output high in the off state (74HC04 or similar) is recommended for maintaining good common mode noise immunity. Open collector drive that allows IN1 and IN2 to float will degrade common mode noise immunity and is therefore not recommended.

The fault signal line on pin 4 of CN1 is active low which means that a fault condition will be indicated by a low level signal. During normal operation pin 4 is pulled high to the +V_L supply by the 4.7K resistor R3. If either of the hybrid gate drivers detects a short circuit condition its fault isolation opto (OP1, OP2) will turn on and pull pin 4 of CN1 low. When a fault is detected the hybrid gate drivers disable the output and produce a fault signal for a minimum of 1ms. Any signal on the fault line that is significantly shorter than 1ms can not be a legitimate fault so it should be ignored. Therefore, for a robust noise immune design, it is recommended that an RC filter with a time constant of approximately 10μs be added between pin 4 and the controller as shown in figure 4.

Thermistor Connection: The case temperature of the NX series device can be monitored by reading the resistance value of the built in NTC Thermistor. This is accessed on the BG2D board at TH connector pins 1 and 2. The relationship between the resistance and the temperature measurement is given by the B constant as shown in equation 1. Solving for temperature of any given point T_x, with a reference temperature of 25°C we can come up with equation 2. Equation 2 is very useful because R₂₅, the resistance with a case temperature of

25°C can be easily measured. It is important to note that this equation is valid for temperatures measured in Kelvin (K) in which case $T_{25} = 25+273 = 298K$.

$$\text{EQ.1: } B = (\ln R_1 - \ln R_2) / (1/T_1 - 1/T_2)$$

$$\text{EQ.2: } T_x = B / (\ln R_x - \ln R_{25}) + T_{25}$$

Figure 5: BG2D Printed Circuit Board Layout

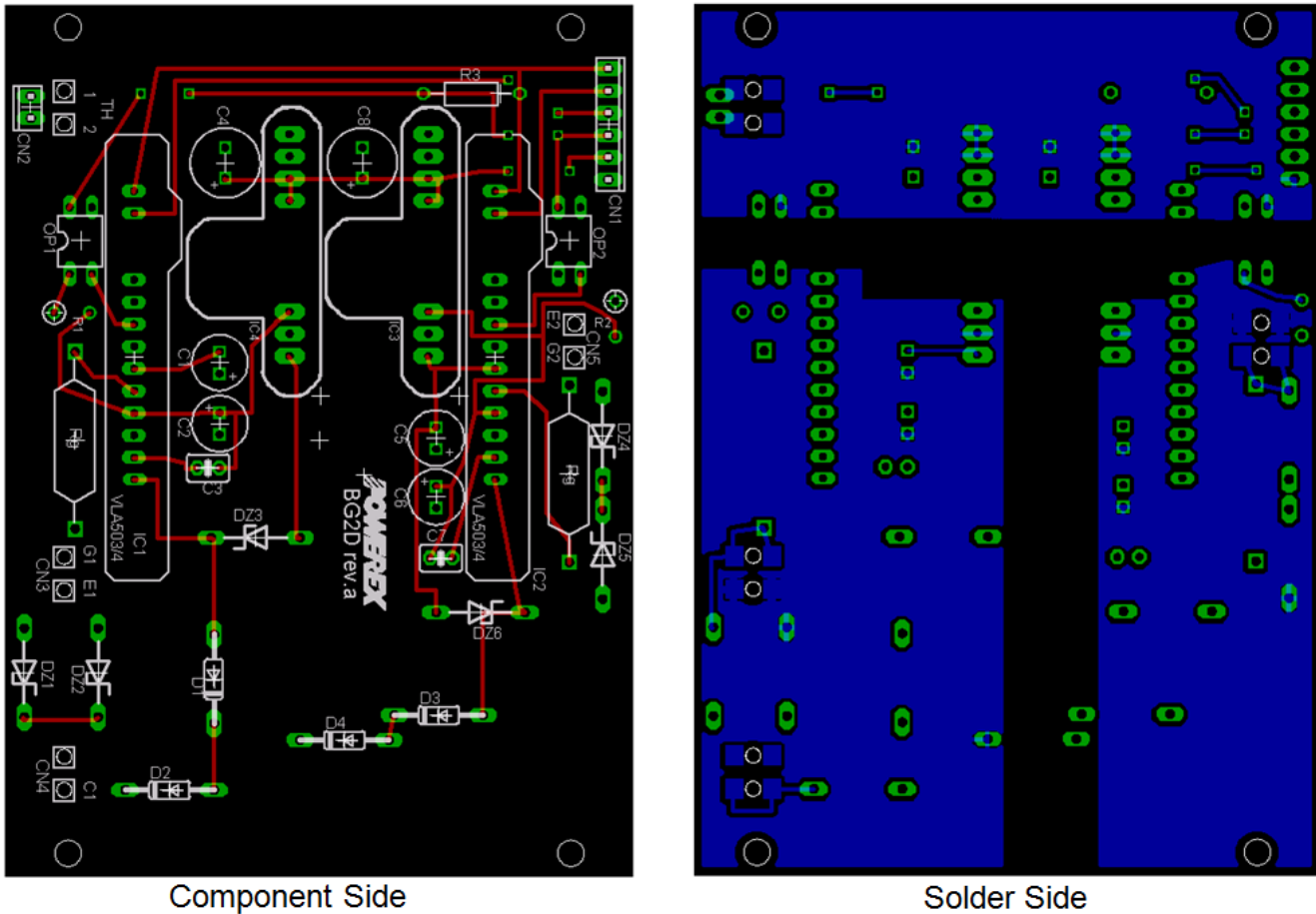

Printed Circuit Layout: Figure 5 shows the layout of the BG2D two channel gate driver board. The compact 3" x 2.2" circuit board with only 28 components clearly demonstrates the advantage of using hybrid gate drivers and DC to DC converters. One important feature is the use of three ground plane islands for the regions of the PCB having high voltage differences. Two of the islands are tied to the IGBT emitter/circuit common (Pin 2 of the DC to DC converters) of each output channel. The third island is connected to logic interface common at pin 6 of CN1. This layout provides shielding to help prevent undesirable coupling of noise between the control side and the gate drive channels.

Additional Information: Detailed information about the operation and electrical characteristics of the M57159L-01, VLA503-01 and VLA-504-01 hybrid gate drivers can be found on the individual device data sheets. Electrical characteristics such as input voltage range, efficiency, and output voltage regulation of the VLA106-15242 and VLA106-24242 DC to DC converters can also be found on the individual device data sheets. Information about calculating gate drive current and selection of series gate resistors (R_G) can be found in the general IGBT module and gate drive application notes. For applications using higher current IGBT modules refer to the application notes for the VLA500-01 hybrid gate driver and BG2A reference design. For applications using high frequency optimized NFH series IGBT modules refer to the VLA502-01 application note. All of these documents

are available on the Powerex website at www.pwrx.com. For design assistance with any of the products covered in this application note contact your local Powerex representative or Powerex application engineering at (724) 925-7272.