



Chipsmall Limited consists of a professional team with an average of over 10 year of expertise in the distribution of electronic components. Based in Hongkong, we have already established firm and mutual-benefit business relationships with customers from,Europe,America and south Asia,supplying obsolete and hard-to-find components to meet their specific needs.

With the principle of “Quality Parts,Customers Priority,Honest Operation,and Considerate Service”,our business mainly focus on the distribution of electronic components. Line cards we deal with include Microchip,ALPS,ROHM,Xilinx,Pulse,ON,Everlight and Freescale. Main products comprise IC,Modules,Potentiometer,IC Socket,Relay,Connector.Our parts cover such applications as commercial,industrial, and automotives areas.

We are looking forward to setting up business relationship with you and hope to provide you with the best service and solution. Let us make a better world for our industry!



## Contact us

Tel: +86-755-8981 8866 Fax: +86-755-8427 6832

Email & Skype: info@chipsmall.com Web: www.chipsmall.com

Address: A1208, Overseas Decoration Building, #122 Zhenhua RD., Futian, Shenzhen, China



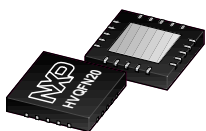

# BGA3131

## DOCSIS 3.1 upstream amplifier

Rev. 1 — 13 May 2016

Product data sheet

## 1. General description

The BGA3131 is an upstream amplifier meeting the Data Over Cable Service Interface Specifications (DOCSIS 3.1). It is designed for cable modem, CATV set top box and VoIP modem applications. The device operates from 5 MHz to 205 MHz. The BGA3131 provides 58 dB gain control range in 1 dB increments with high incremental accuracy. Its maximum gain setting delivers 37 dB voltage gain and a superior linear performance.

It supports the DOCSIS 3.1 output power levels while meeting the stringent ACLR requirements.

The BGA3131 operates at 5 V supply. The gain is controlled via a 3-wire serial interface (SPI-Bus). The current consumption can be reduced in 4 steps via the serial interface. This interface enables the user to optimize between DC power efficiency and linearity. In addition, the current is automatically reduced at lower gain settings while preserving the linearity performance. In disable mode, the device draws typically 25 mA while it can be still programmed to new gain and current settings.

The BGA3131 is housed in 20 pins 5 mm × 5 mm leadless HVQFN package.

## 2. Features and benefits

- 58 dB gain control range in 1 dB steps using a 3-wire serial interface
- 5 MHz to 205 MHz frequency operating range
- $\pm 0.4$  dB incremental gain step accuracy
- Maximum voltage gain 37 dB
- Excellent IMD3 of  $-60$  dBc at 68 dBmV total output power
- Excellent second harmonic level of  $-60$  dBc at 68 dBmV total output power
- Excellent third harmonic level of  $-60$  dBc at 68 dBmV total output power
- Excellent noise figure of 6.5 dB at maximum gain
- Capable of transmitting modulated carriers while meeting the DOCSIS 3.1 ACLR specification. At an output power of 65 dBmV at the F-connector (assuming 3 dB of output loss), the typical ACLR is  $-64$  dBc
- 5 V single supply operation
- Excellent ESD protection at all pins
- Unconditionally stable
- Compliant to Directive 2002/95/EC, regarding Restriction of Hazardous Substances (RoHS)



### 3. Applications

- DOCSIS 3.1 and 3.0 cable modems
- VoIP modems
- Set-top boxes

### 4. Quick reference data

**Table 1. Quick reference data**

Typical values at  $V_{CC} = 5\text{ V}$ ; current setting = 3 mA; gain setting 50 up to and including 63;  $T_{case} = 25\text{ °C}$ ;  $Z_{i(dif)} = 200\ \Omega$ ;  $Z_{o(se)} = 75\ \Omega$ ; voltage gain does include loss due to output transformer; unless otherwise specified. All RF parameters are measured on an application board with the circuit as shown in [Figure 12](#) and components implemented as listed in [Table 15](#).

Symbol	Parameter	Conditions	Min	Typ	Max	Unit
$I_{CC}$	supply current	transmit-enable mode; TX_EN = HIGH	610	660	720	mA
		transmit-disable mode; TX_EN = LOW	-	25	-	mA
$G_v$	voltage gain	gain code = 111111 <a href="#">[1][2]</a>	-	37	-	dB
NF	noise figure	transmit-enable mode; gain code = 111111	-	6.5	-	dB
$\alpha_{2H}$	second harmonic level	transmit-enable mode; gain code = 111111; $P_i(\text{RMS}) = 31.0\text{ dBmV}$ ; $P_L(\text{RMS}) = 68.0\text{ dBmV}$ into 75 $\Omega$ impedance	-	-65	-	dBc
$\alpha_{3H}$	third harmonic level	transmit-enable mode; gain code = 111111; $P_i(\text{RMS}) = 31.0\text{ dBmV}$ ; $P_L(\text{RMS}) = 68.0\text{ dBmV}$ into 75 $\Omega$ impedance	-	-65	-	dBc
IMD3	third-order intermodulation distortion	transmit-enable mode; gain code = 111111; $P_L(\text{RMS}) = 65.0\text{ dBmV}$ per tone into 75 $\Omega$ impedance	-	-60	-	dBc
$P_{L(1dB)}$	output power at 1 dB gain compression	CW input signal RMS value; frequency = 205 MHz	-	78	-	dBmV

[1]  $P_i \leq 30\text{ dBmV}$ .

[2] Excluding 5.7 dB loss of resistive matching circuit, to match 75  $\Omega$  to 50  $\Omega$ .

**Table 2. ACLR quick reference data**

Typical values at  $V_{CC} = 5\text{ V}$ ; current setting = 3 mA; Gain setting 60;  $T_{case} = 25\text{ °C}$ ;  $Z_{i(dif)} = 200\ \Omega$ ;  $Z_{o(se)} = 75\ \Omega$ ; channel bandwidth = 192 MHz; integration bandwidth = 9.6 MHz;  $f = 5\text{ MHz}$  to 205 MHz; unless otherwise specified.

Symbol	Parameter	Conditions	Min	Typ	Max	Unit
<b>DOCSIS 3.1</b>						
ACLR	adjacent channel leakage ratio	$P_i(\text{RMS}) = 34\text{ dBmV}$ ; $P_L(\text{RMS}) = 68\text{ dBmV}$ . Channel configuration: channel bandwidth is 192 MHz, with exclusion band at 147.5 MHz; with a bandwidth of 9.6 MHz. Input signal with a PAPR of 13 dB	-	-64	-58	dBc

### 5. Ordering information

**Table 3. Ordering information**

Type number	Package		Version
	Name	Description	
BGA3131	HVQFN20	plastic thermal enhanced very thin quad flat package; no leads; 20 terminals; body 5 × 5 × 0.85 mm	SOT662-1

## 6. Functional diagram

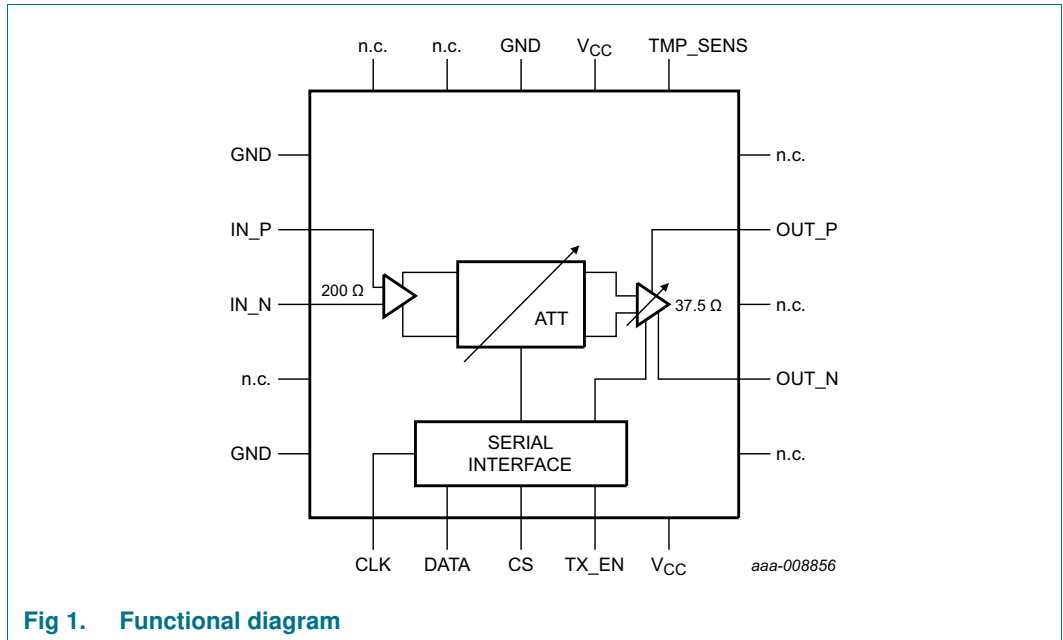

Fig 1. Functional diagram

## 7. Pinning information

### 7.1 Pinning

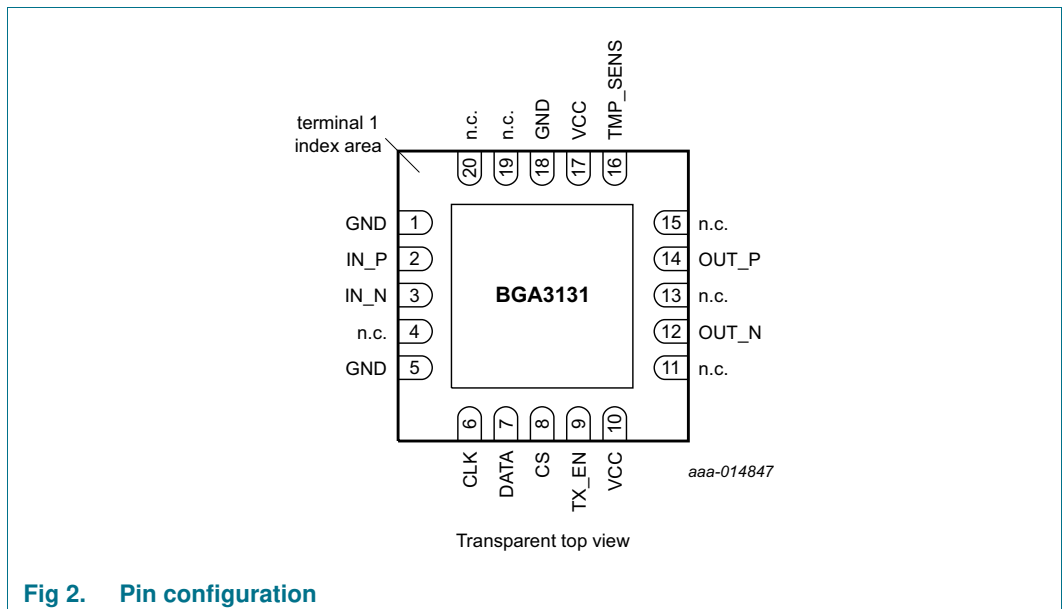

Fig 2. Pin configuration

## 7.2 Pin description

Table 4. Pin description

Symbol	Pin	Description
GND	1	ground
IN_P	2	amplifier input +
IN_N	3	amplifier input –
n.c.	[1] 4	not connected
GND	5	ground
CLK	6	clock
DATA	7	data
CS	8	chip select
TX_EN	9	transmit enable active high
V <sub>CC</sub>	10	supply voltage
n.c.	[1] 11	not connected
OUT_N	12	amplifier output –
n.c.	[1] 13	not connected, pin can be left open, grounded or connected to the center tap voltage in the application
OUT_P	14	amplifier output +
n.c.	[1] 15	not connected
TMP_SENS	16	temperature sense
V <sub>CC</sub>	17	supply voltage
GND	18	ground
n.c.	[1] 19	not connected
n.c.	[1] 20	not connected
GND	die paddle	ground

[1] not connected pins can either be left open or grounded in the application.

## 8. Functional description

### 8.1 Logic programming

The programming word is set through a shift register. It uses the data of the SPI bus (pin name DATA), clock (pin name CLK), and enable (pin name TX\_EN) lines. By default, the data is entered in order with the most significant bit (MSB) first and the least significant bit (LSB) last. The Chip Select line (CS) must be low during the data entry, then set high to sample the shift register. The rising edge of the clock pulse shifts each data value into the shift register. When the register is programmed, the new settings take effect:

- on the rising, edge of CS, IF TX\_EN is HIGH
- on the rising, edge of TX\_EN if TX\_EN is LOW

**Table 5. Programming register**

Data bit	11	10	9	8	7	6	5	4	3	2	1	0
Function	Register address				Current settings <sup>[1]</sup>		attenuation (gain) settings <sup>[2]</sup>					
Settings	0	0	0	0	C[1]	C[0]	G[5]	G[4]	G[3]	G[2]	G[1]	G[0]
Initialize	0	0	0	1	Soft reset (mirror)	LSB first (mirror)	ASC address (mirror)	16b mode (mirror)	16b mode	ASC address	LSB first	Soft reset
Reserved	0	0	1	0	0	0	0	0	0	0	0	0
Reserved	0	0	1	1	0	0	0	0	0	0	0	0

[1] For current bit settings, see [Table 7](#).

[2] For gain bit settings, see [Table 6](#).

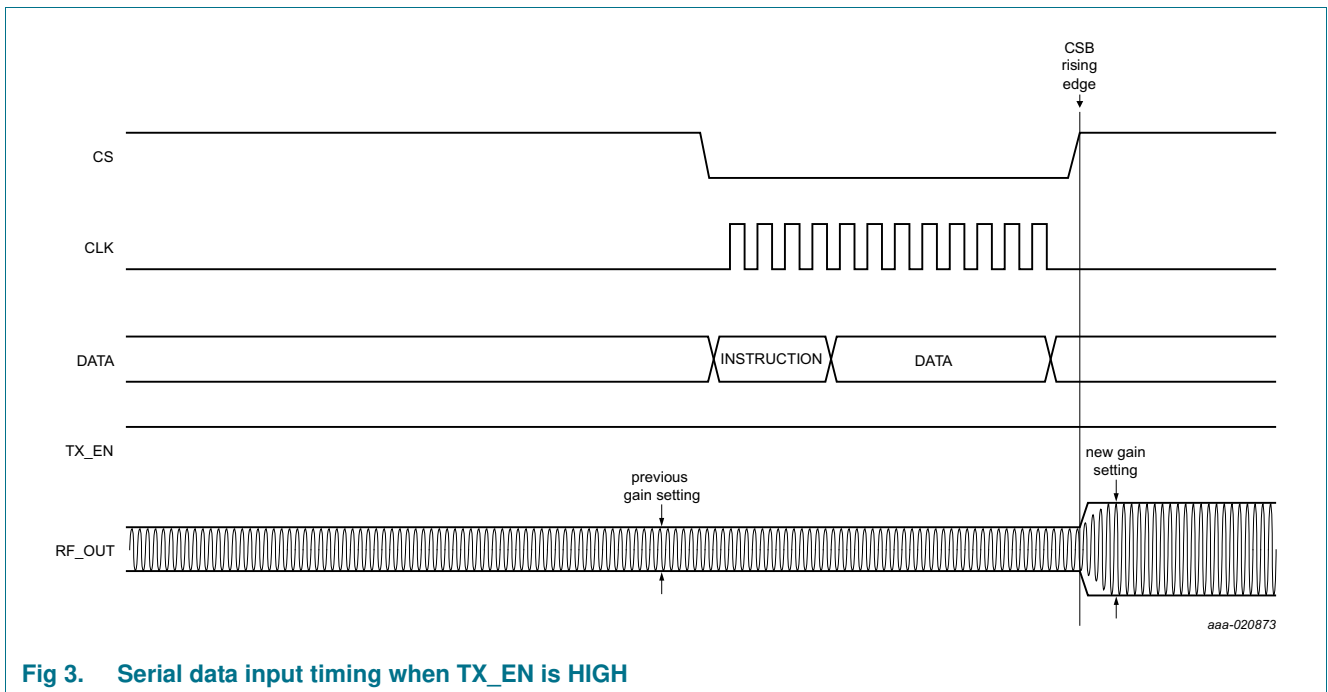

**Fig 3. Serial data input timing when TX\_EN is HIGH**

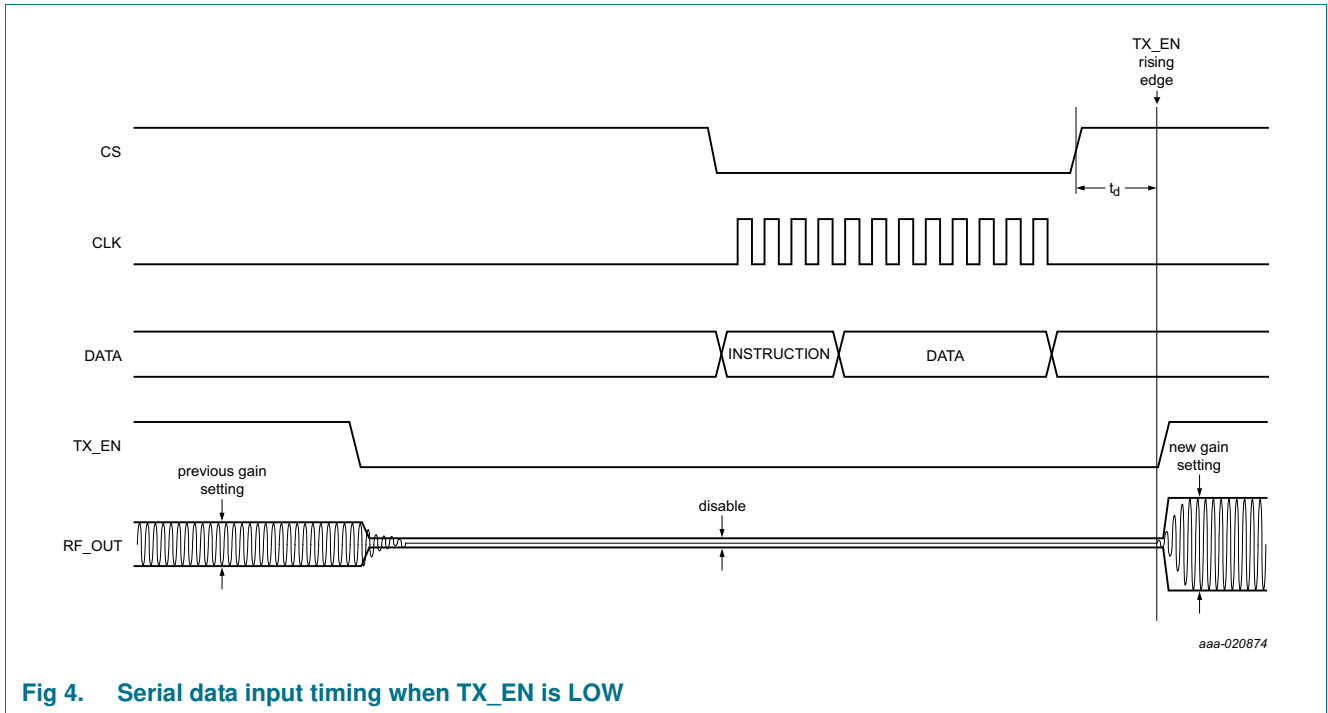

Fig 4. Serial data input timing when TX\_EN is LOW

## 8.2 Register settings

### 8.2.1 Register address

Only addresses 0000 to 0011 are used. Using any other addresses do not affect the VGA. Address 0000 is used to configure attenuation and current parameters of the device. Address 0001 is used to configure the SPI interface specifically. Addresses 0010 and 0011 are reserved, and must be kept at value 0.

### 8.2.2 Gain/attenuator setting

The gain shall be controlled via the SPI bus. Data bits D0 through D5 set the gain/attenuator level, with 111111 being the min attenuation setting, and 000101 being the maximum attenuation setting. A new gain/attenuator setting can be loaded while the VGA is on (transmit-enable).

Table 6. Gain settings

Gain setting G[5:0] <sup>[1]</sup>		Typical gain
binary notation	decimal notation	(dB)
000000 to 000101	0 to 5	-21
000110	6	-20
111110	62	36
111111	63	37

[1] With every increment of the gain setting between 000101 (5) and 111111 (63), the typical gain increases accordingly.

### 8.2.3 Output stage current setting

The current (of the output stage) shall be controlled via the 3-wire bus. Data bits D6 and D7 set the current. Setting 11 sets the maximum current for maximum linearity. The current can be lowered for improved efficiency at lower output power levels, or lower linearity requirements. Setting 00 sets the minimum current. A new current setting can be loaded while the VGA is on (transmit-enable).

**Table 7. Supply current settings**  
At gain setting 63.

Current setting C[1:0]		Typical supply current
binary notation	decimal notation	(mA)
00	0	350
01	1	410
10	2	480
11	3	660

The current is automatically reduced at lower gain settings while preserving the linearity performance.

**Table 8. Device current setting versus gain setting**

Gain setting		Typical current (mA)				Comments
Attenuation bit [5.0]	H value	Current setting C[1:0] = 00	Current setting C[1:0] = 01	Current setting C[1:0] = 10	Current setting C[1:0] = 11	
111111	0x3F	315	410	480	660	Max.gain (code = 63)
110001	0x31	280	315	345	370	Gain code = 49
101011	0x2B	290	320	350	375	Gain code = 43
100101	0x25	240	260	260	330	Gain code = 37
011001	0x19	220	235	235	250	Gain code = 25

### 8.2.4 SPI Initialize register

The SPI receiver may be configured in several communication modes. By default, the device is waiting for a 12 bit, MSB first SPI frame. In that case, the address field is 4 bit wide and the data field is 8 bit wide. Using the Initialize register at address 0x01 allows switching the device to different SPI modes. Register 0x01 contains four effective bits, but programmed with the mirror value of the 4 LSBs in the 4 MSBs.

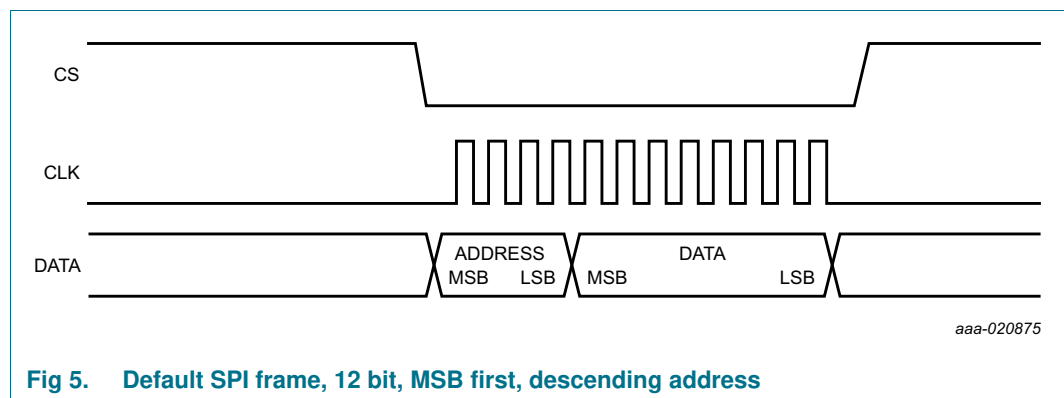
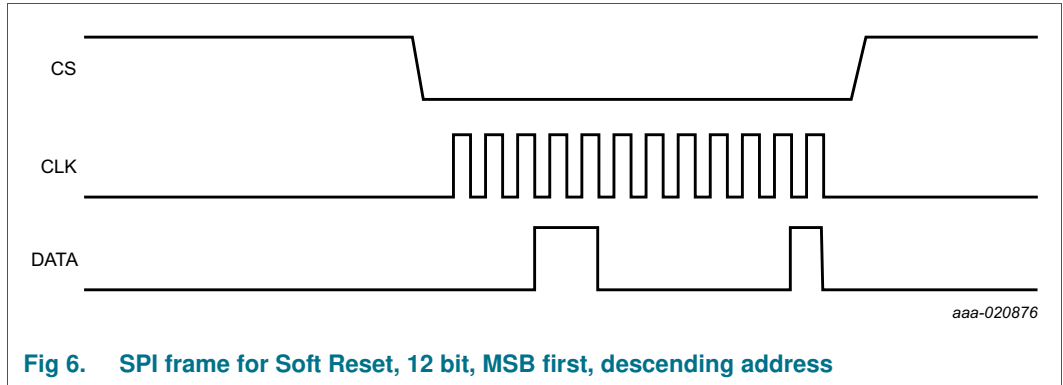

**Fig 5. Default SPI frame, 12 bit, MSB first, descending address**



**8.2.4.1 SPI Soft Reset**

By setting bits *Soft\_reset* AND *Soft\_reset (mirror)* at address 0x01, the device is set to its default state (maximum gain).



**8.2.4.2 SPI 16-bit mode**

By default, the SPI frame is made of 4 bits for address and a multiple of 8 bits for data. By setting bits *16b\_mode* AND *16b\_mode (mirror)* at address 0x01, the device is configured such that the next SPI command will be a 16-bit command. Address is sent on 8 bits, whereas data is a multiple of 8 bits.

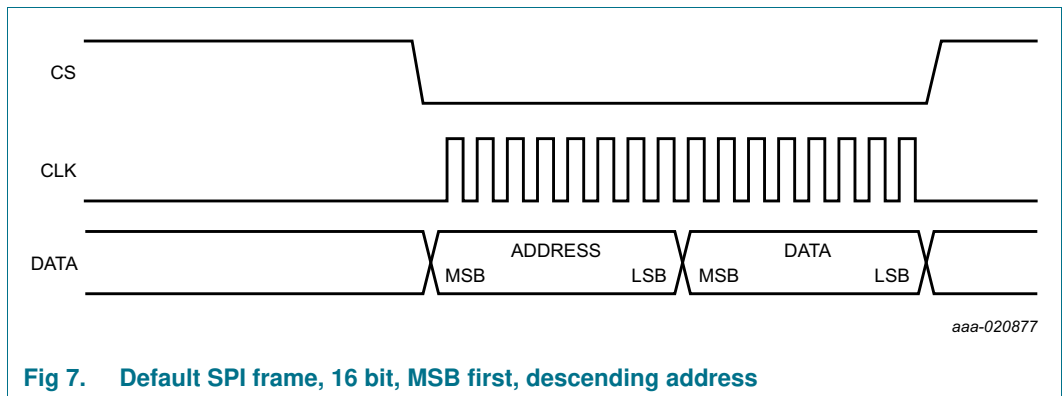

**8.2.4.3 SPI ascending address**

By default, the SPI slave can be programmed with a single SPI frame. The SPI contains a start address and several data bytes to be written at the start address. It has an auto decrementing mechanism to store data in the corresponding register. By setting bits *asc\_addr* AND *asc\_addr (mirror)* at address 0x01, the device is configured so that the internal addresses are auto-incremented instead of auto-decremented.

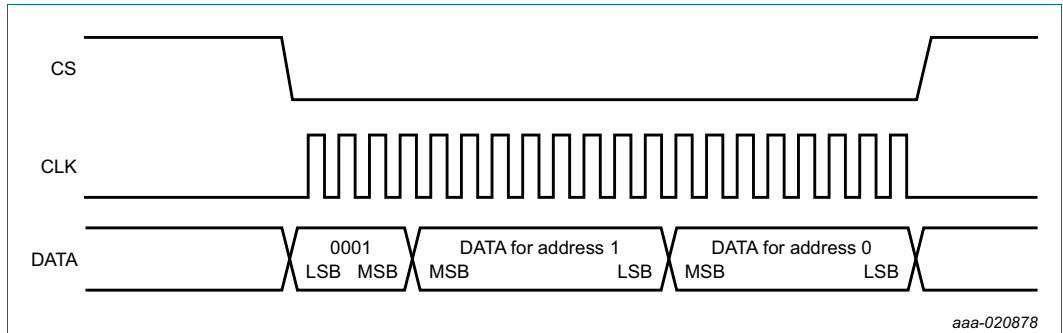

**Fig 8. Burst SPI frame, 12 bit, MSB first, descending address**

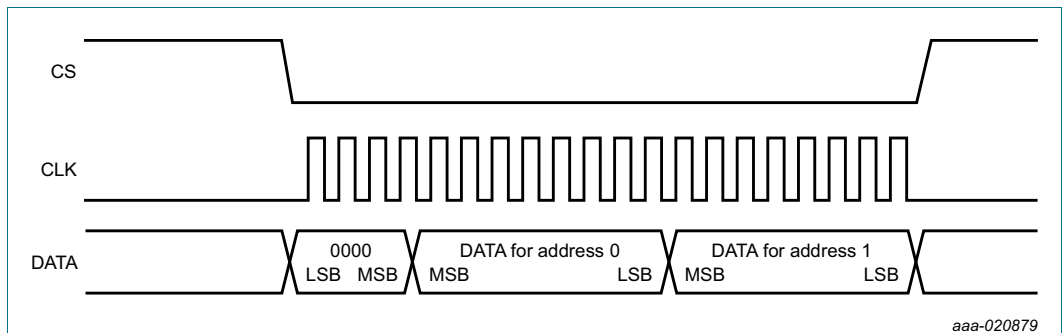

**Fig 9. Burst SPI frame, 12 bit, MSB first, ascending address**

**8.2.4.4 SPI LSB first**

By default, the SPI slave waits for the MSB data first. By setting bits *lsb\_first* AND *lsb\_first (mirror)* at address 0x01, the device is configured. The first bit received is considered as the LSB of each field (address and data).

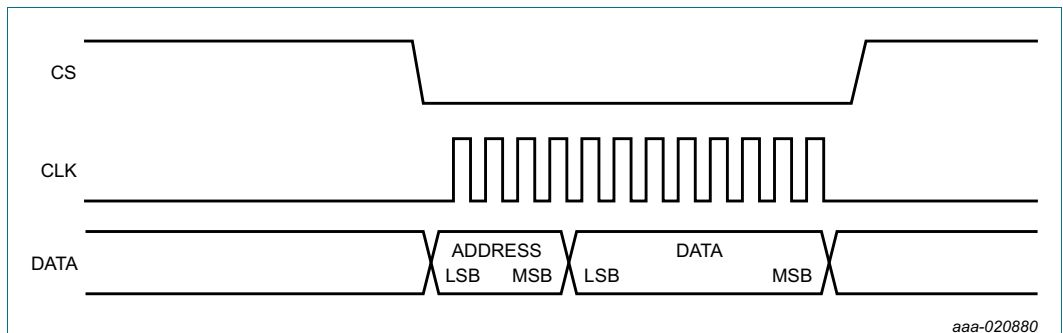

**Fig 10. Burst SPI frame, 12 bit, MSB first, descending address**

**8.3 TX enable / TX disable**

The amplifier can be disabled or enabled by making TX\_EN (pin 9) LOW or HIGH. A LOW to HIGH TX enable transition enables new programmed settings. If no new settings are programmed, the last programmed setting is reactivated.

## 9. Limiting values

**Table 9. Limiting values**

In accordance with the Absolute Maximum Rating System (IEC 60134).

Absolute maximum ratings are given as limiting values of stress conditions during operation, that must not be exceeded under the worst probable conditions.

Symbol	Parameter	Conditions	Min	Max	Unit
$V_{CC}$	supply voltage		-	6.0	V
$I_i$	input current	on pin TMP_SENS	-	1	mA
$V_i$	input voltage	on pin IN_P	-0.5	+6.0	V
		on pin IN_N	-0.5	+6.0	V
		on pin CLK <a href="#">[1]</a>	-0.5	+6.0	V
		on pin DATA <a href="#">[1]</a>	-0.5	+6.0	V
		on pin CS <a href="#">[1]</a>	-0.5	+6.0	V
		on pin TX_EN <a href="#">[1]</a>	-0.5	+6.0	V
		on pin OUT_N	-0.5	+6.0	V
		on pin OUT_P	-0.5	+6.0	V
$P_{I(max)}$	maximum input power		-	60	dBmV
$T_{stg}$	storage temperature		-55	+150	°C
$T_j$	junction temperature		-	150	°C
$V_{ESD}$	electrostatic discharge voltage	Human Body Model (HBM); according to JEDEC standard 22-A114E <a href="#">[2]</a>	-	±4	kV
		Charged Device Model (CDM); according to JEDEC standard 22-C101B <a href="#">[2]</a>	-	±2	kV
$f_{SPI}$	SPI frequency	Master writes to slave; load on DATA line 30 pF maximum. Under nominal $V_{IL}$ and $V_{IH}$ levels	-	25	MHz

[1] All digital pins must not exceed  $V_{CC}$  as the internal ESD circuit can be damaged. To prevent this damage, it is recommended that control pins are limited to a maximum of 5 mA.

[2] Stressed with pulses of 200 ms in duration.

## 10. Thermal characteristics

**Table 10. Thermal characteristics**

Symbol	Parameter	Conditions	Typ	Unit
$R_{th(j-bop)}$	thermal resistance from junction to bottom of package	Still air, natural convection <a href="#">[1]</a>	6.1	K/W
$R_{th(j-a)}$	thermal resistance from junction to ambient	Still air, natural convection <a href="#">[1]</a>	29.3	K/W
$\Psi_{(j-top)}$	thermal characterization parameter from junction to top of package	Still air, natural convection <a href="#">[1]</a>	9.9	K/W

[1] Simulated using final element method model resembling the device mounted on the application board. See [Figure 13](#).

For more thermal details, refer to the BGA3131 *Thermal management guidelines AN11753* at [www.nxp.com](http://www.nxp.com).

### 10.1 Thermal compact model

Compact thermal model parameters (Delphi compact model), definitions according to [Figure 11](#)

**Table 11. Delphi model parameters<sup>[1]</sup>**

R <sub>th</sub> (K/W)	junction	top inner	top outer	bottom inner	bottom outer	sides	leads	surface areas [mm <sup>2</sup> ]
junction		201		6.17				
top inner			1207	543	1330			4.27
top outer				114	60.4		222	20.7
bottom inner					53.8	315	311	9.53
bottom outer							37.8	12.6
sides							101	17.0
leads								2.85

[1] Cells are intentionally left empty.

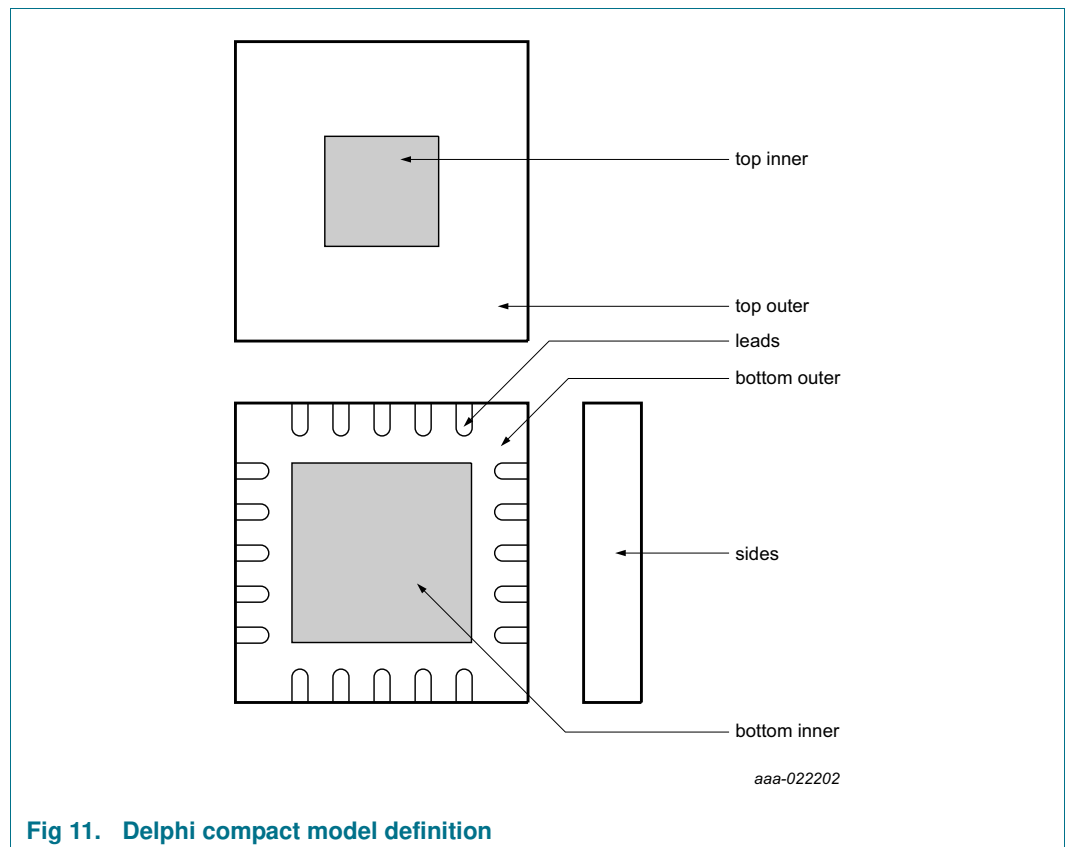

## 11. Static characteristics

**Table 12. Characteristics**

Typical values at  $V_{CC} = 5\text{ V}$ ; current setting = 3 mA; gain setting 50 up to and including 63;  $T_{case} = 25\text{ °C}$ ;  $Z_{i(dif)} = 200\ \Omega$ ;  $Z_{o(se)} = 75\ \Omega$ ; unless otherwise specified.

Symbol	Parameter	Conditions	Min	Typ	Max	Unit	
$V_{CC}$	supply voltage		4.75	5.0	5.25	V	
$I_{CC}$	supply current	transmit-enable mode; TX_EN = HIGH	610	660	720	mA	
		transmit-disable mode; TX_EN = LOW	-	25	-	mA	
$V_{IH}$	HIGH-level input voltage		[1]	1.8	-	$V_{CC} + 0.6$	V
$V_{IL}$	LOW-level input voltage		[1]	0	-	0.8	V
P	power dissipation		-	3.3			W

[1] Voltage on the control pins.

## 12. Dynamic characteristics

**Table 13. Characteristics**

Typical values at  $V_{CC} = 5\text{ V}$ ; current setting = 3 mA; gain setting 15 up to and including 63;  $T_{case} = 25\text{ °C}$ ;  $Z_{i(dif)} = 200\ \Omega$ ;  $Z_{o(se)} = 75\ \Omega$ ; voltage gain does include loss due to output transformer; unless otherwise specified. All RF parameters are measured on an application board with the circuit as shown in [Figure 12](#) and components implemented as listed in [Table 15](#).

Symbol	Parameter	Conditions	Min	Typ	Max	Unit	
$G_v$	voltage gain	gain code = 111111	[1][2]	-	37	-	dB
		gain code = 001111	[1][2]	-	-11	-	dB
$G_{flat}$	gain flatness	f = 5 MHz to 205 MHz	[1]	-	$\pm 0.5$	-	dB
$RL_{out}$	output return loss	transmit mode enable over all gain settings, measured in 75 $\Omega$ system		-	14	-	dB
		transmit mode disable over all gain settings, measured in 75 $\Omega$ system		-	12	-	dB
$RL_{in}$	input return loss	transmit mode enable overall gain settings, measured in 200 $\Omega$ system		-	20	-	dB
		transmit modes disable overall gain settings, measured in 200 $\Omega$ system		-	20	-	dB
$G_{step}$	gain step		[1]	-	1.0	-	dB
$E_{G(dif)}$	differential gain error		[1]	-	$\pm 0.4$	-	dB
$R_{i(dif)}$	differential input resistance			-	200	-	$\Omega$
$R_{o(dif)}$	differential output resistance			-	37.5	-	$\Omega$
$f_{range}$	frequency range			5	-	205	MHz
$\alpha_{isol}$	isolation	transmit-disable mode; TX_EN = LOW; f = 205 MHz		-	60	-	dB
NF	noise figure	transmit mode; gain code = 111111		-	6.5	-	dB
		transmit mode; gain code = 100110		-	15	-	dB
$t_{sw(G)}$	gain switch time	transmit-disable/transmit-enable transient duration		-	3.0	-	$\mu\text{s}$
		transmit-enable/transmit-disable transient duration		-	0.5	-	$\mu\text{s}$

**Table 13. Characteristics ...continued**

Typical values at  $V_{CC} = 5\text{ V}$ ; current setting = 3 mA; gain setting 15 up to and including 63;  $T_{case} = 25\text{ °C}$ ;  $Z_{i(dif)} = 200\ \Omega$ ;  $Z_{o(se)} = 75\ \Omega$ ; voltage gain does include loss due to output transformer; unless otherwise specified. All RF parameters are measured on an application board with the circuit as shown in [Figure 12](#) and components implemented as listed in [Table 15](#).

Symbol	Parameter	Conditions	Min	Typ	Max	Unit	
V <sub>trt</sub>	transient voltage	transmit-disable/transmit-enable transient step size; peak value					
		≥ 58 dBmV output power	[3][4]	-	45	-	mV
		52 dBmV output power	[3][4]	-	15	-	mV
		46 dBmV output power	[3][4]	-	10	-	mV
		40 dBmV output power	[3][4]	-	5	-	mV
		≤ 34 dBmV output power	[3][4]	-	3	-	mV
α <sub>2H</sub>	second harmonic level	transmit-enable mode; gain code = 111111; P <sub>i</sub> = 31.0 dBmV(rms); P <sub>L</sub> = 68.0 dBmV(rms) into 75 Ω impedance	-	-65	-	dBc	
α <sub>3H</sub>	third harmonic level	transmit-enable mode; gain code = 111111; P <sub>i</sub> = 31.0 dBmV(rms); P <sub>L</sub> = 68.0 dBmV(rms) into 75 Ω impedance	-	-65	-	dBc	
IMD3	third-order intermodulation distortion	transmit-enable mode; gain code = 111111; P <sub>L</sub> = 65 dBmV(rms) per tone into 75 Ω impedance	-	-60	-	dBc	
P <sub>L(1dB)</sub>	output power at 1 dB gain compression	CW input signal RMS value; frequency = 205 MHz	-	78	-	dBmV	

- [1] P<sub>i</sub> ≤ 30 dBmV.
- [2] Excluding loss of resistive matching circuit, to match 75Ω to 50 Ω.
- [3] Measured at the output of the output balun.
- [4] Assume 3 dB loss between by output of the balun and F-connector in the final application.

**Table 14. ACLR characteristics**

Typical values at  $V_{CC} = 5\text{ V}$ ; current setting = 3 mA; Gain setting 60;  $T_{case} = 25\text{ °C}$ ;  $Z_{i(dif)} = 200\ \Omega$ ;  $Z_{o(se)} = 75\ \Omega$ ; channel bandwidth = 192 MHz; integration bandwidth = 9.6 MHz;  $f = 5\text{ MHz to }205\text{ MHz}$ ; unless otherwise specified.

Symbol	Parameter	Conditions	Min	Typ	Max	Unit
<b>DOCSIS 3.1</b>						
ACLR	adjacent channel leakage ratio	P <sub>i</sub> (RMS) = 34 dBmV; P <sub>L</sub> (RMS) = 68 dBmV. Channel configuration: channel bandwidth is 192 MHz, with exclusion band at 147.5 MHz; with a bandwidth of 9.6 MHz. Input signal with a PAPR of 13 dB	-	-64	-58	dBc

## 13. External components

---

Matching the balanced output of the chip to a single-ended  $75\ \Omega$  load is accomplished using a 1: 2 ratio transformer. For measurements in a  $50\ \Omega$  system, R5 and R6 are added for impedance transformation from  $75\ \Omega$  to  $50\ \Omega$ . R5 and R6 are not required in the final application.

The transformer also cancels even mode distortion products and common mode signals, such as the voltage transients that occur while enabling and disabling the amplifiers.

External capacitors are needed for the functionality of the circuit, the pins are internal nodes in the output amplifier. The measured voltage on the temperature sense pin 16 at an input current of 1 mA, is related to the die temperature.

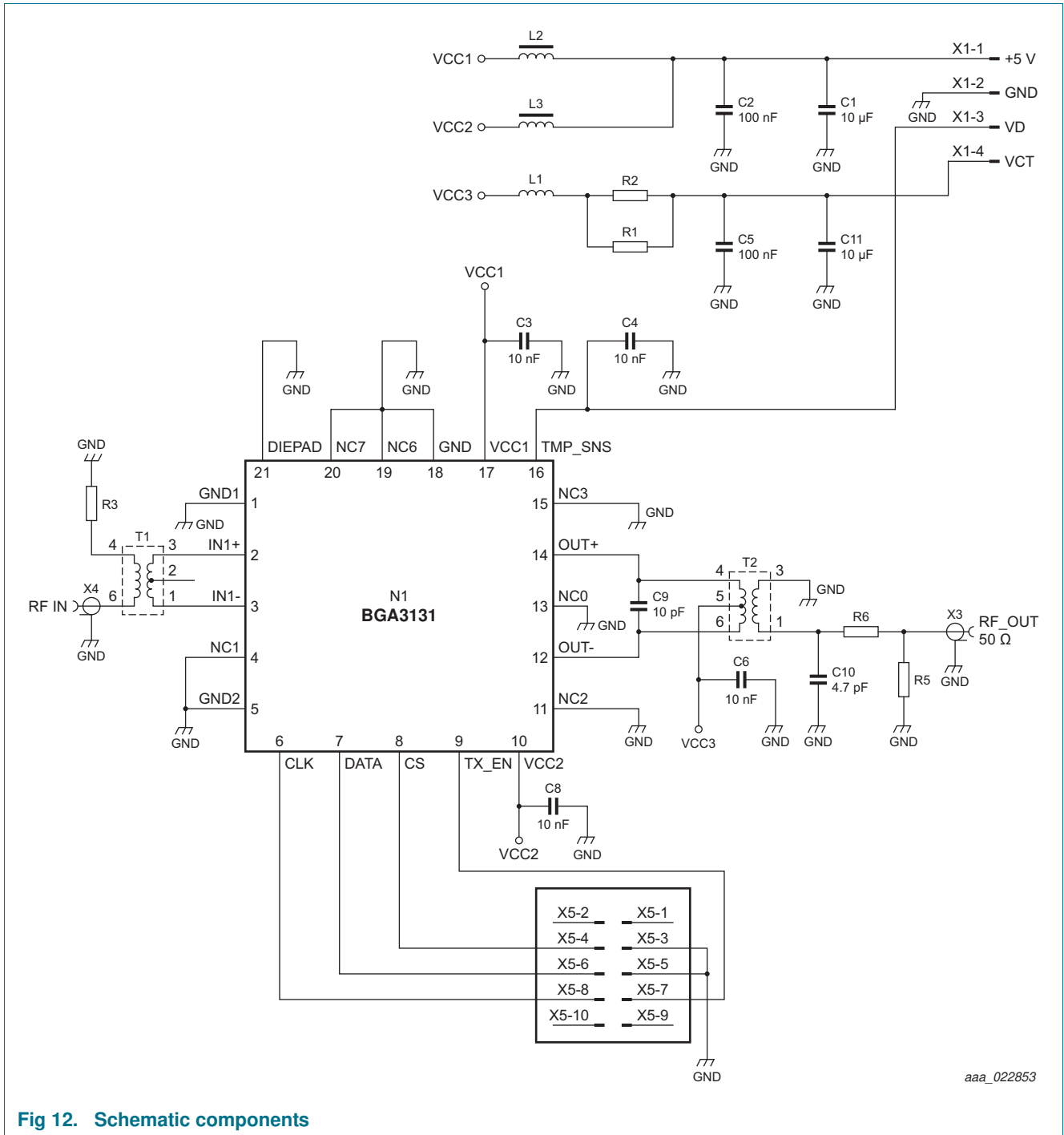

aaa\_022853

Fig 12. Schematic components



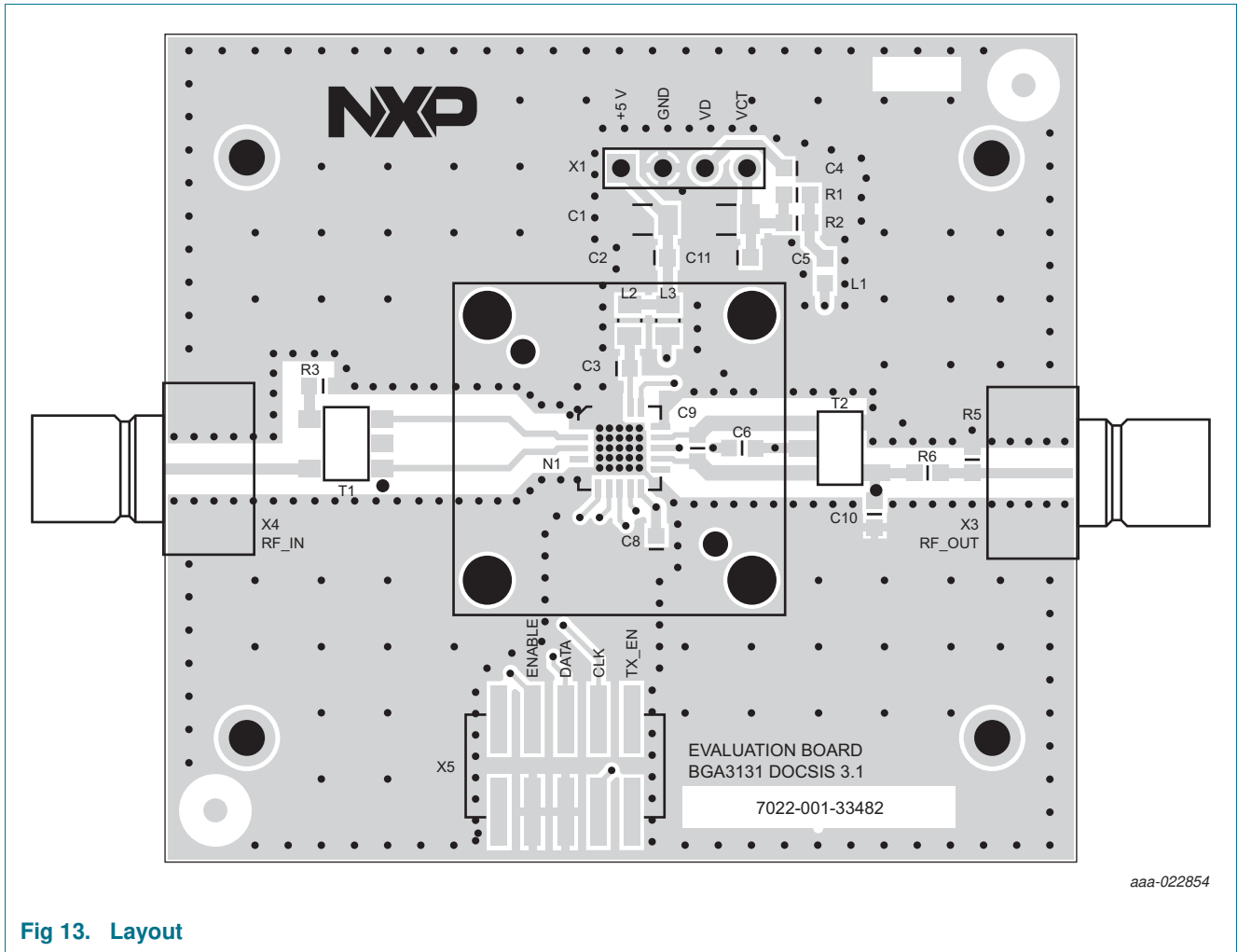

Fig 13. Layout

Table 15. List of components

For application diagram, see [Figure 12](#).

Component	Description	Value	Size	Supplier: Part No.
C1, C11	capacitor	10 $\mu$ F	SMD 1206	
C2, C5	capacitor	100 nF	SMD 0603	
C3, C4, C6, C8	capacitor	10 nF	SMD 0603	
C9	capacitor	10 pF	SMD 0603	
C10	capacitor	4.7 pF	SMD 0603	
L1	place holder for optional inductor	-	-	on EVB 0 $\Omega$ mounted
L2, L3	place holder for option chokes	-	-	on EVB 0 $\Omega$ mounted
N1	amplifier	-	-	NXP: BGA3131
R1, R2	resistor	0 $\Omega$	SMD 0603	
R3	resistor	0 $\Omega$	SMD 0603	
R5	resistor	86.6 $\Omega$	SMD 0603	75 $\Omega$ to 50 $\Omega$ conversion for measurement purpose only
R6	resistor	43.2 $\Omega$	SMD 0603	75 $\Omega$ to 50 $\Omega$ conversion for measurement purpose only

**Table 15. List of components ...continued**  
For application diagram, see [Figure 12](#).

Component	Description	Value	Size	Supplier: Part No.
T1	transformer	-	-	TOKO: #617PT-1664
T2	transformer	-	-	MACOM: MABA-011056
X1	header, 4P	-	-	
X3, X4	SMA connector	-	-	
X5	header, 10P	-	-	

## 14. Application information

### 14.1 Graphics

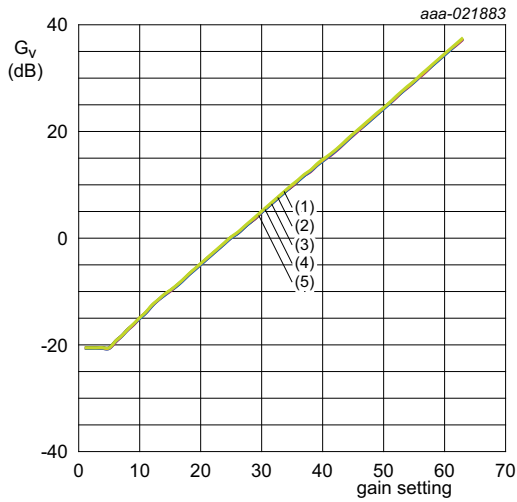

$V_{CC} = 5\text{ V}$ ; current setting = 3;  $T_{amb} = 25\text{ }^\circ\text{C}$

- (1) frequency = 5 MHz
- (2) frequency = 50 MHz
- (3) frequency = 100 MHz
- (4) frequency = 150 MHz
- (5) frequency = 205 MHz

Fig 14.  $G_v$  as function of gain setting, typical values

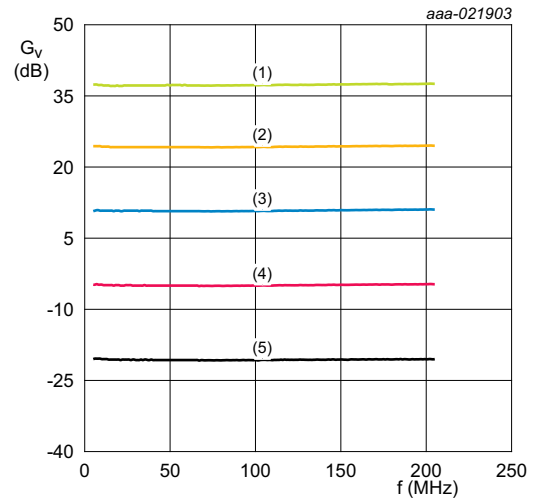

$V_{CC} = 5\text{ V}$ ; current setting = 3;  $T_{amb} = 25\text{ }^\circ\text{C}$

- (1)  $gs = 63$
- (2)  $gs = 50$
- (3)  $gs = 36$
- (4)  $gs = 20$
- (5)  $gs = 5$

Fig 15.  $G_v$  as function of frequency, typical values

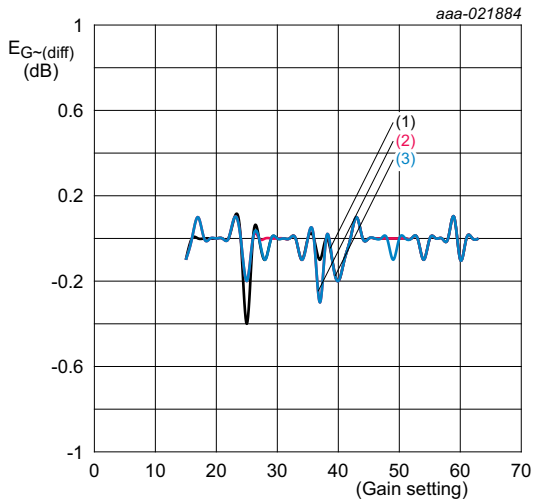

$V_{CC} = 5\text{ V}$ ; current setting = 3;  $T_{amb} = 25\text{ }^{\circ}\text{C}$   
 (1) frequency = 5 MHz  
 (2) frequency = 100 MHz  
 (3) frequency = 200 MHz

**Fig 16. Differential gain error as function of gain setting; typical values**

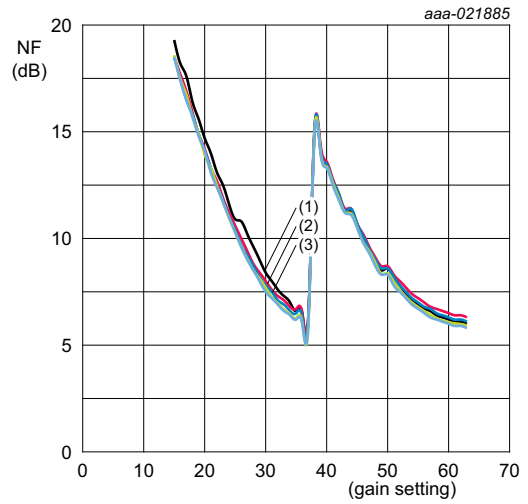

$V_{CC} = 5\text{ V}$ ; current setting = 3;  $T_{amb} = 25\text{ }^{\circ}\text{C}$   
 (1) frequency = 5 MHz  
 (2) frequency = 50 MHz  
 (3) frequency = 100 MHz  
 (4) frequency = 150 MHz  
 (5) frequency = 205 MHz

**Fig 17. Noise figure as function of gain setting; typical values**

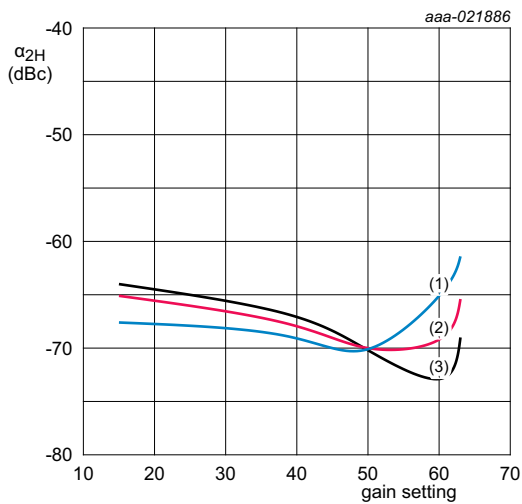

$V_{CC} = 5\text{ V}$ ; current setting = 3;  $T_{amb} = 25\text{ }^{\circ}\text{C}$ ;  
 $P_L = 68\text{ dBmV}$ ; fundamental frequency = 102 MHz;  
 Measurement frequency = 204 MHz  
 (1)  $T_{amb} = -40\text{ }^{\circ}\text{C}$   
 (2)  $T_{amb} = +25\text{ }^{\circ}\text{C}$   
 (3)  $T_{amb} = +85\text{ }^{\circ}\text{C}$

**Fig 18. Second order harmonic level as function of gain setting; typical values**

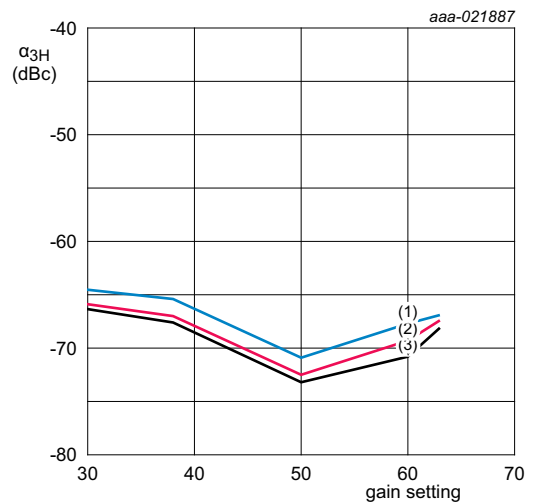

$V_{CC} = 5\text{ V}$ ; current setting = 3;  $T_{amb} = 25\text{ }^{\circ}\text{C}$ ;  
 $P_L = 68\text{ dBmV}$ ; fundamental frequency = 68 MHz;  
 Measurement frequency = 204 MHz  
 (1)  $T_{amb} = -40\text{ }^{\circ}\text{C}$   
 (2)  $T_{amb} = +25\text{ }^{\circ}\text{C}$   
 (3)  $T_{amb} = +85\text{ }^{\circ}\text{C}$

**Fig 19. Third order harmonic level as function of gain setting; typical values**

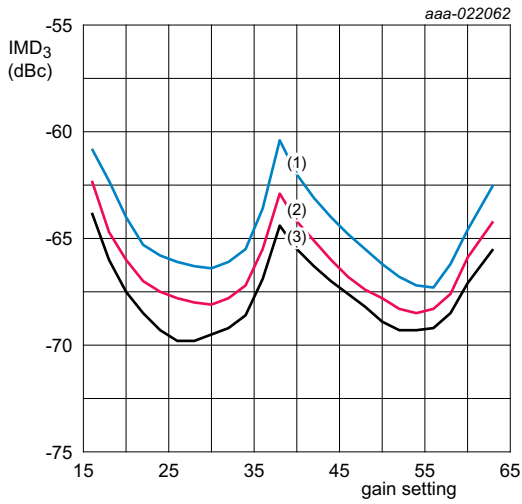

$V_{CC} = 5\text{ V}$ ; current setting = 3;  $T_{amb} = 25\text{ }^{\circ}\text{C}$ ;  
 $P_L$  per tone = 65 dBmV  
 (1) frequency = 204 MHz  
 (2) frequency = 100 MHz  
 (3) frequency = 5 MHz

**Fig 20. Third order intermodulation distortion as a function of gain setting; typical values**

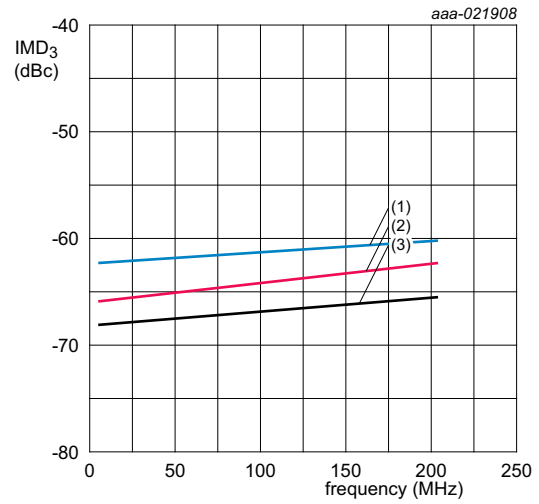

$V_{CC} = 5\text{ V}$ ; current setting = 3;  $T_{amb} = 25\text{ }^{\circ}\text{C}$ ;  
 $P_L$  per tone = 65 dBmV;  $gs = 60$   
 (1)  $T_{amb} = -40\text{ }^{\circ}\text{C}$   
 (2)  $T_{amb} = +25\text{ }^{\circ}\text{C}$   
 (3)  $T_{amb} = +85\text{ }^{\circ}\text{C}$

**Fig 21. Third order intermodulation distortion as function of temperature; typical values**

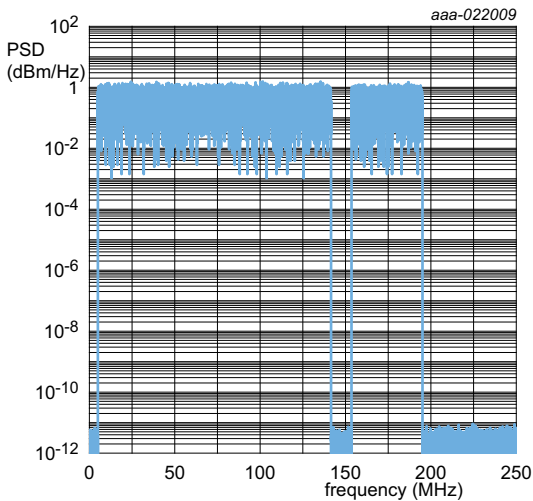

OFDM input signal for ACLR measurements, total bandwidth = 192 MHz; exclusion band @147.5 MHz, all with a bandwidth of 9.6 MHz.  
 Peak-to-average (PAR) ratio of the signal = 13 dB.

**Fig 22. Power Spectral Density of input signal used for ACLR measurements.**

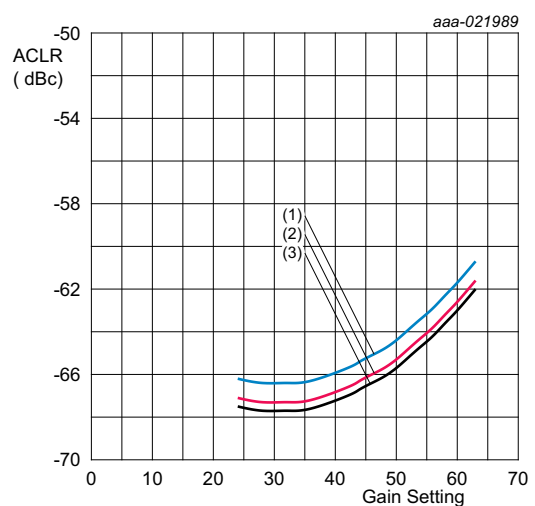

$V_{CC} = 5\text{ V}$ ; current setting = 3;  
 $P_{in} = 34\text{ dBmV}$  up to  $gs = 60$   
 At  $gs = 61; 62$  and  $63$ ;  $P_{out} = 68\text{ dBmV}$   
 Input signal applied as described in Fig.22  
 (1)  $T_{amb} = -40\text{ }^{\circ}\text{C}$   
 (2)  $T_{amb} = +25\text{ }^{\circ}\text{C}$   
 (3)  $T_{amb} = +85\text{ }^{\circ}\text{C}$

**Fig 23. Adjacent channel leakage ratio as function of temperature; typical values.**

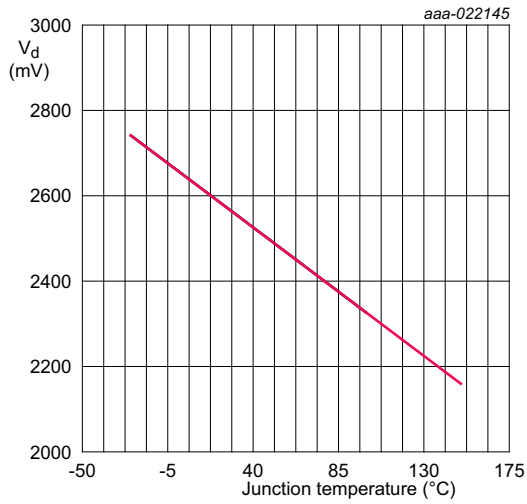

V<sub>CC</sub> = 5 V; current setting = 3  
 TMP\_SENS; DC current = 1 mA  
 gs = 63

Fig 24. Thermal diode voltage as function of junction temperature; typical values.

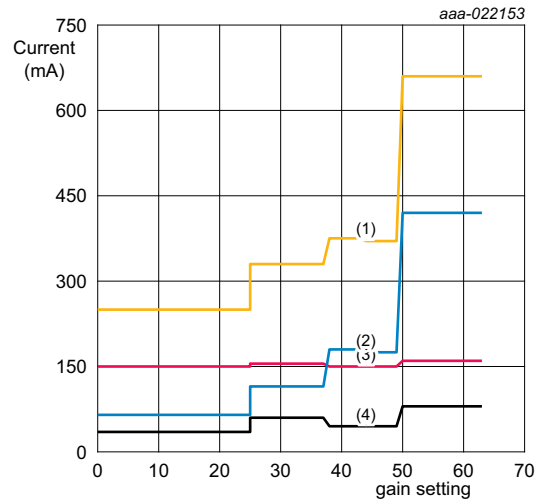

V<sub>CC</sub> = 5 V; current setting = 3; T<sub>amb</sub> = 25 °C;  
 (1) total current; I<sub>CC1</sub> + I<sub>CC2</sub> + ICT  
 (2) ICT; output balun center tap current  
 (3) I<sub>CC1</sub>; current through Pin #17 (V<sub>CC1</sub>)  
 (4) I<sub>CC2</sub>; current through Pin #16 (V<sub>CC2</sub>)

Fig 25. DC-current as function of gain setting; typical values.

15. Package outline

HVQFN20: plastic thermal enhanced very thin quad flat package; no leads;  
20 terminals; body 5 x 5 x 0.85 mm

SOT662-1

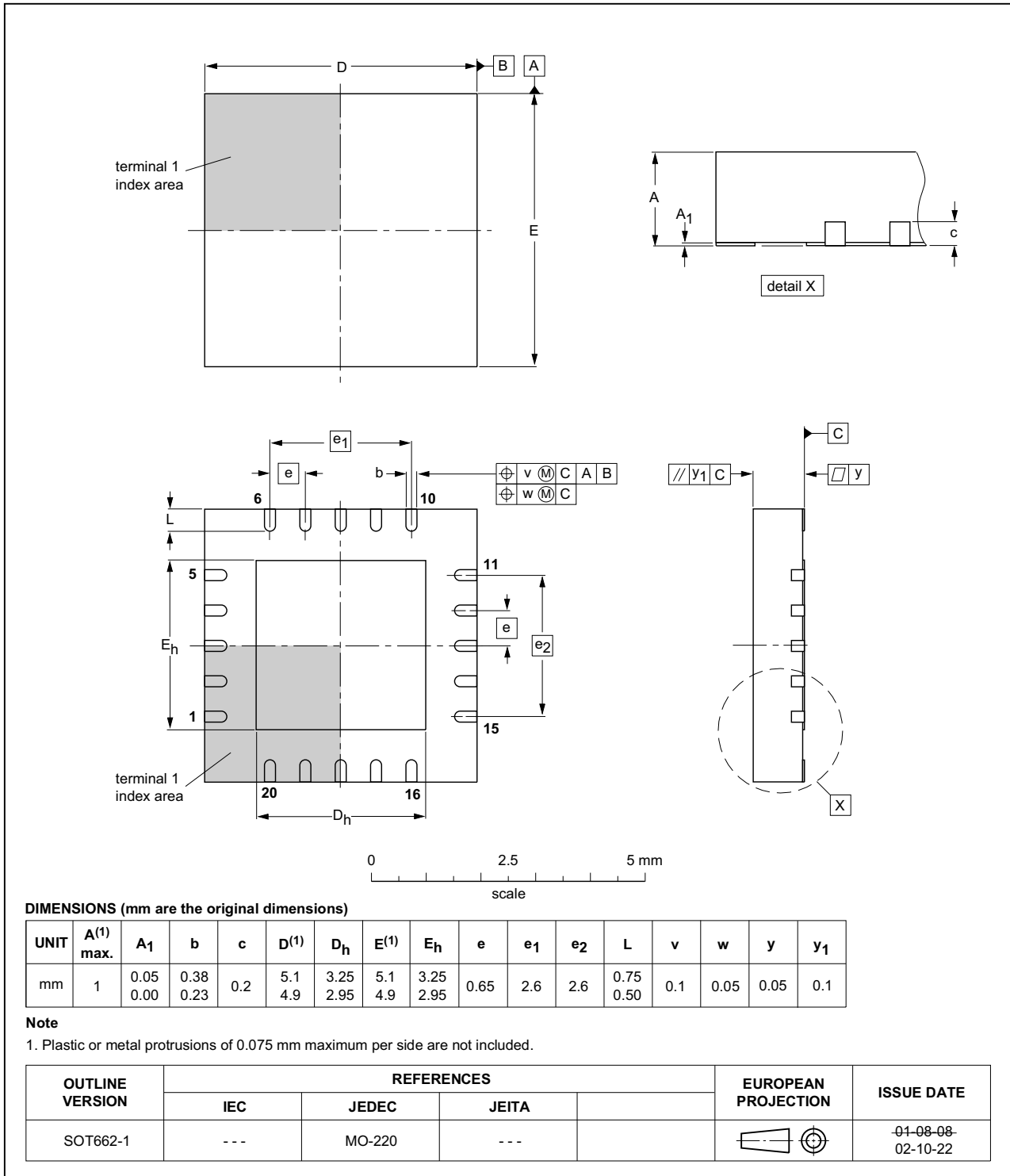

Fig 26. Package outline SOT662-1 (HVQFN20)

## 16. Handling information

### 16.1 Moisture sensitivity

Table 16. Moisture sensitivity level

Test methodology	Class
JESD-22-A113	MSL 1

## 17. Abbreviations

Table 17. Abbreviations

Acronym	Description
ACLR	Adjacent Channel Leakage Ratio
CATV	Community Antenna Television
CW	Continuous Wave
ESD	ElectroStatic Discharge
HVQFN	Heat sink Very thin Quad Flat pack No leads
OFDM	Orthogonal Frequency Division Multiplexing
PAPR	Peak-to-Average Power Ratio
SMA	Sub-Miniature version A
SMD	Surface-Mounted Device
TX	Transmission
VoIP	Voice over Internet Protocol

## 18. Revision history

Table 18. Revision history

Document ID	Release date	Data sheet status	Change notice	Supersedes
BGA3131 v.1	20160513	Product data sheet	-	-



## 19. Legal information

### 19.1 Data sheet status

Document status <sup>[1][2]</sup>	Product status <sup>[3]</sup>	Definition
Objective [short] data sheet	Development	This document contains data from the objective specification for product development.
Preliminary [short] data sheet	Qualification	This document contains data from the preliminary specification.
Product [short] data sheet	Production	This document contains the product specification.

[1] Please consult the most recently issued document before initiating or completing a design.

[2] The term 'short data sheet' is explained in section "Definitions".

[3] The product status of device(s) described in this document may have changed since this document was published and may differ in case of multiple devices. The latest product status information is available on the Internet at URL <http://www.nxp.com>.

### 19.2 Definitions

**Draft** — The document is a draft version only. The content is still under internal review and subject to formal approval, which may result in modifications or additions. NXP Semiconductors does not give any representations or warranties as to the accuracy or completeness of information included herein and shall have no liability for the consequences of use of such information.

**Short data sheet** — A short data sheet is an extract from a full data sheet with the same product type number(s) and title. A short data sheet is intended for quick reference only and should not be relied upon to contain detailed and full information. For detailed and full information see the relevant full data sheet, which is available on request via the local NXP Semiconductors sales office. In case of any inconsistency or conflict with the short data sheet, the full data sheet shall prevail.

**Product specification** — The information and data provided in a Product data sheet shall define the specification of the product as agreed between NXP Semiconductors and its customer, unless NXP Semiconductors and customer have explicitly agreed otherwise in writing. In no event however, shall an agreement be valid in which the NXP Semiconductors product is deemed to offer functions and qualities beyond those described in the Product data sheet.

### 19.3 Disclaimers

**Limited warranty and liability** — Information in this document is believed to be accurate and reliable. However, NXP Semiconductors does not give any representations or warranties, expressed or implied, as to the accuracy or completeness of such information and shall have no liability for the consequences of use of such information. NXP Semiconductors takes no responsibility for the content in this document if provided by an information source outside of NXP Semiconductors.

In no event shall NXP Semiconductors be liable for any indirect, incidental, punitive, special or consequential damages (including - without limitation - lost profits, lost savings, business interruption, costs related to the removal or replacement of any products or rework charges) whether or not such damages are based on tort (including negligence), warranty, breach of contract or any other legal theory.

Notwithstanding any damages that customer might incur for any reason whatsoever, NXP Semiconductors' aggregate and cumulative liability towards customer for the products described herein shall be limited in accordance with the *Terms and conditions of commercial sale* of NXP Semiconductors.

**Right to make changes** — NXP Semiconductors reserves the right to make changes to information published in this document, including without limitation specifications and product descriptions, at any time and without notice. This document supersedes and replaces all information supplied prior to the publication hereof.

**Suitability for use** — NXP Semiconductors products are not designed, authorized or warranted to be suitable for use in life support, life-critical or safety-critical systems or equipment, nor in applications where failure or malfunction of an NXP Semiconductors product can reasonably be expected to result in personal injury, death or severe property or environmental damage. NXP Semiconductors and its suppliers accept no liability for inclusion and/or use of NXP Semiconductors products in such equipment or applications and therefore such inclusion and/or use is at the customer's own risk.

**Applications** — Applications that are described herein for any of these products are for illustrative purposes only. NXP Semiconductors makes no representation or warranty that such applications will be suitable for the specified use without further testing or modification.

Customers are responsible for the design and operation of their applications and products using NXP Semiconductors products, and NXP Semiconductors accepts no liability for any assistance with applications or customer product design. It is customer's sole responsibility to determine whether the NXP Semiconductors product is suitable and fit for the customer's applications and products planned, as well as for the planned application and use of customer's third party customer(s). Customers should provide appropriate design and operating safeguards to minimize the risks associated with their applications and products.

NXP Semiconductors does not accept any liability related to any default, damage, costs or problem which is based on any weakness or default in the customer's applications or products, or the application or use by customer's third party customer(s). Customer is responsible for doing all necessary testing for the customer's applications and products using NXP Semiconductors products in order to avoid a default of the applications and the products or of the application or use by customer's third party customer(s). NXP does not accept any liability in this respect.

**Limiting values** — Stress above one or more limiting values (as defined in the Absolute Maximum Ratings System of IEC 60134) will cause permanent damage to the device. Limiting values are stress ratings only and (proper) operation of the device at these or any other conditions above those given in the Recommended operating conditions section (if present) or the Characteristics sections of this document is not warranted. Constant or repeated exposure to limiting values will permanently and irreversibly affect the quality and reliability of the device.

**Terms and conditions of commercial sale** — NXP Semiconductors products are sold subject to the general terms and conditions of commercial sale, as published at <http://www.nxp.com/profile/terms>, unless otherwise agreed in a valid written individual agreement. In case an individual agreement is concluded only the terms and conditions of the respective agreement shall apply. NXP Semiconductors hereby expressly objects to applying the customer's general terms and conditions with regard to the purchase of NXP Semiconductors products by customer.

**No offer to sell or license** — Nothing in this document may be interpreted or construed as an offer to sell products that is open for acceptance or the grant, conveyance or implication of any license under any copyrights, patents or other industrial or intellectual property rights.

**Export control** — This document as well as the item(s) described herein may be subject to export control regulations. Export might require a prior authorization from competent authorities.

**Quick reference data** — The Quick reference data is an extract of the product data given in the Limiting values and Characteristics sections of this document, and as such is not complete, exhaustive or legally binding.

**Non-automotive qualified products** — Unless this data sheet expressly states that this specific NXP Semiconductors product is automotive qualified, the product is not suitable for automotive use. It is neither qualified nor tested in accordance with automotive testing or application requirements. NXP Semiconductors accepts no liability for inclusion and/or use of non-automotive qualified products in automotive equipment or applications.

In the event that customer uses the product for design-in and use in automotive applications to automotive specifications and standards, customer (a) shall use the product without NXP Semiconductors' warranty of the

product for such automotive applications, use and specifications, and (b) whenever customer uses the product for automotive applications beyond NXP Semiconductors' specifications such use shall be solely at customer's own risk, and (c) customer fully indemnifies NXP Semiconductors for any liability, damages or failed product claims resulting from customer design and use of the product for automotive applications beyond NXP Semiconductors' standard warranty and NXP Semiconductors' product specifications.

**Translations** — A non-English (translated) version of a document is for reference only. The English version shall prevail in case of any discrepancy between the translated and English versions.

## 19.4 Trademarks

Notice: All referenced brands, product names, service names and trademarks are the property of their respective owners.

## 20. Contact information

For more information, please visit: <http://www.nxp.com>

For sales office addresses, please send an email to: [salesaddresses@nxp.com](mailto:salesaddresses@nxp.com)