



Chipsmall Limited consists of a professional team with an average of over 10 year of expertise in the distribution of electronic components. Based in Hongkong, we have already established firm and mutual-benefit business relationships with customers from,Europe,America and south Asia,supplying obsolete and hard-to-find components to meet their specific needs.

With the principle of “Quality Parts,Customers Priority,Honest Operation,and Considerate Service”,our business mainly focus on the distribution of electronic components. Line cards we deal with include Microchip,ALPS,ROHM,Xilinx,Pulse,ON,Everlight and Freescale. Main products comprise IC,Modules,Potentiometer,IC Socket,Relay,Connector.Our parts cover such applications as commercial,industrial, and automotives areas.

We are looking forward to setting up business relationship with you and hope to provide you with the best service and solution. Let us make a better world for our industry!



Contact us

Tel: +86-755-8981 8866 Fax: +86-755-8427 6832

Email & Skype: info@chipsmall.com Web: www.chipsmall.com

Address: A1208, Overseas Decoration Building, #122 Zhenhua RD., Futian, Shenzhen, China



BGA622L7

Silicon Germanium Wide Band Low Noise
Amplifier with 2 kV ESD Protection

Small Signal Discretes



Never stop thinking

Edition 2008-04-14

**Published by Infineon Technologies AG,
81726 München, Germany**

**© Infineon Technologies AG 2008.
All Rights Reserved.**

Attention please!

The information herein is given to describe certain components and shall not be considered as a guarantee of characteristics.

Terms of delivery and rights to technical change reserved.

We hereby disclaim any and all warranties, including but not limited to warranties of non-infringement, regarding circuits, descriptions and charts stated herein.

Information

For further information on technology, delivery terms and conditions and prices please contact your nearest Infineon Technologies Office (www.infineon.com).

Warnings

Due to technical requirements components may contain dangerous substances. For information on the types in question please contact your nearest Infineon Technologies Office.

Infineon Technologies Components may only be used in life-support devices or systems with the express written approval of Infineon Technologies, if a failure of such components can reasonably be expected to cause the failure of that life-support device or system, or to affect the safety or effectiveness of that device or system. Life support devices or systems are intended to be implanted in the human body, or to support and/or maintain and sustain and/or protect human life. If they fail, it is reasonable to assume that the health of the user or other persons may be endangered.

BGA622L7, Silicon Germanium Wide Band Low Noise Amplifier with 2 kV ESD Protection**Revision History: 2008-04-14, Rev. 2.2****Previous Version: 2006-05-19**

Page	Subjects (major changes since last revision)
All	Document layout change

TrademarksSIEGET[®] is a registered trademark of Infineon Technologies AG.

1 Silicon Germanium Wide Band Low Noise Amplifier with 2 kV ESD Protection

Feature

- High gain
 - $|S_{21}|^2 = 17.5$ dB at 1.575 GHz
 - $|S_{21}|^2 = 16.8$ dB at 1.9 GHz
 - $|S_{21}|^2 = 16.2$ dB at 2.14 GHz
- Low noise figure, $NF = 0.95$ dB at 1.575 GHz
- Operating frequency range 0.5 - 6 GHz
- Typical supply voltage: 2.75 V
- On/Off-Switch
- Output-match on chip, input pre-matched
- Low external part count
- Tiny TSLP-7-1 leadless package
- 70 GHz f_T - Silicon Germanium technology
- 2 kV HBM ESD protection (Pin-to-Pin)
- Pb-free (RoHS compliant) package

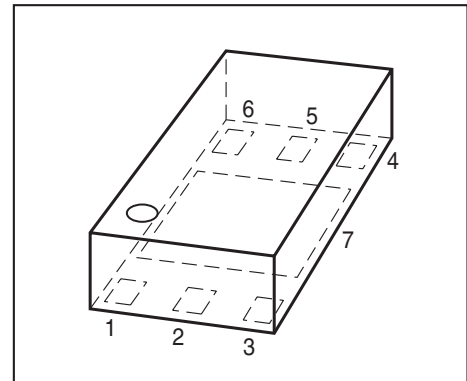

TSLP-7-1



Applications

- LNA for GSM, GPS, DCS, PCS, UMTS, Bluetooth, ISM and WLAN

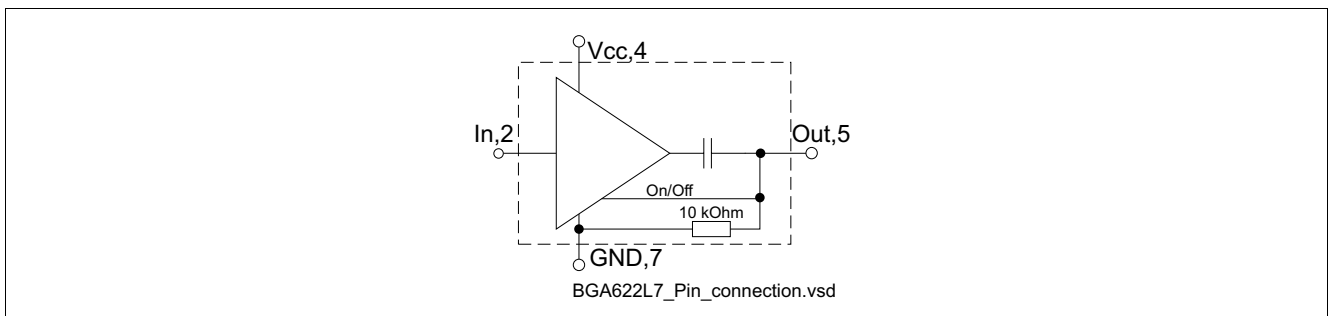

Figure 1 Pin connection

Description

The BGA622L7 is a wide band low noise amplifier, based on Infineon Technologies' Silicon Germanium Technology B7HF. The out-pin is simultaneously used for RF out and On/Off switch. This functionality can be accessed using a RF-Choke at the Out pin, where a DC level of 0 V or an open switches the device on and a DC level of V_{CC} switches off, it provides an insertion loss of 26 dB together with a high IIP_3 up to 24 dBm at GPS frequencies.

Type	Package	Marking
BGA622L7	TSLP-7-1	BX

Note: **ESD:** Electrostatic discharge sensitive device, observe handling precaution

2 Maximum Ratings

Table 1 Maximum ratings

Parameter	Symbol	Limit Value	Unit
Voltage at pin V_{CC}	V_{CC}	3.5	V
Voltage at pin Out	V_{out}	4	V
Current into pin In	I_{in}	0.1	mA
Current into pin Out	I_{out}	1	mA
Current into pin V_{CC}	I_{VCC}	10	mA
RF input power	P_{in}	6	dBm
Total power dissipation, $T_S < 142\text{ °C}^{1)}$	P_{tot}	35	mW
Junction temperature	T_J	150	°C
Ambient temperature range	T_A	-65... 150	°C
Storage temperature range	T_{STG}	-65... 150	°C
ESD capability all pins (HBM: JESD22-A114)	V_{ESD}	2000	V

1) T_S is measured on the ground lead at the soldering point

Note: All Voltages refer to GND-Node

Thermal resistance

Table 2 Thermal resistance

Parameter	Symbol	Value	Unit
Junction - soldering point ¹⁾	R_{thJS}	240	K/W

1) For calculation of R_{thJA} please refer to Application Note Thermal Resistance

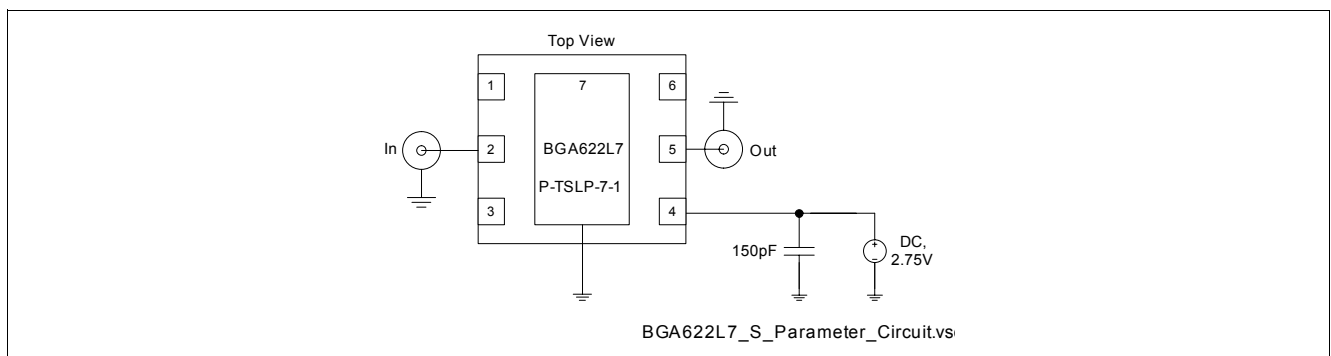

Figure 2 S-Parameter Test Circuit (loss-free microstrip line)

3 Electrical Characteristics

3.1 Electrical Characteristics at $T_A = 25\text{ °C}$ (measured according to [Figure 2](#)) $V_{CC} = 2.75\text{ V}$, Frequency = 1.575 GHz, unless otherwise specified

Table 3 Electrical Characteristics

Parameter	Symbol	Values			Unit	Note / Test Condition
		Min.	Typ.	Max.		
Insertion power gain	$ S_{21} ^2$		17.5		dB	
Insertion power gain (Off-State)	$ S_{21} ^2$		-26		dB	
Input return loss (On-State)	RL_{in}		5		dB	
Output return loss (On-State)	RL_{out}		12		dB	
Noise figure ($Z_S = 50\ \Omega$)	$F_{50\Omega}$		0.95		dB	
Input third order intercept point ¹⁾ (On-State)	IIP_3		-2		dBm	$\Delta f = 1\text{ MHz}$, $P_{IN} = -28\text{ dBm}$
Input third order intercept point ¹⁾ (Off - State)	IIP_3		24		dBm	$\Delta f = 1\text{ MHz}$, $P_{IN} = -8\text{ dBm}$
Input power at 1 dB gain compression	P_{-1dB}		-20		dBm	
Total device off current	$I_{tot-off}$		260		μA	$V_{CC} = 2.75\text{ V}$, $V_{out} = V_{CC}$
Total device on current	I_{tot-on}		5.8		mA	$V_{CC} = 2.75\text{ V}$
On / Off switch control voltage	V_{on}	0		0.8	V	$V_{CC} = 2.75\text{ V}$ ON-Mode: $V_{out} = V_{on}$
	V_{off}	2.0		3.5	V	$V_{CC} = 2.75\text{ V}$ OFF-Mode: $V_{out} = V_{off}$

1) IP_3 values depends on termination of all intermodulation frequency components. Termination used for this measurement is 50 Ω from 0.1 to 6 GHz

3.2 Electrical Characteristics at $T_A = 25\text{ °C}$ (measured according to [Figure 2](#)) $V_{CC} = 2.75\text{ V}$, Frequency = 2.14 GHz, unless otherwise specified

Table 4 Electrical Characteristics

Parameter	Symbol	Values			Unit	Note / Test Condition
		Min.	Typ.	Max.		
Insertion power gain	$ S_{21} ^2$		16.2		dB	
Insertion power gain (Off-State)	$ S_{21} ^2$		-23		dB	
Input return loss (On-State)	RL_{in}		6		dB	
Output return loss (On-State)	RL_{out}		12		dB	
Noise figure ($Z_S = 50\ \Omega$)	$F_{50\Omega}$		1.05		dB	
Input third order intercept point ¹⁾ (On-State)	IIP_3		0		dBm	$\Delta f = 1\text{ MHz}$, $P_{IN} = -28\text{ dBm}$
Input third order intercept point ¹⁾ (Off-State)	IIP_3		22		dBm	$\Delta f = 1\text{ MHz}$, $P_{IN} = -8\text{ dBm}$
Input power at 1 dB gain compression	P_{-1dB}		-16		dBm	

1) IP_3 values depends on termination of all intermodulation frequency components. Termination used for this measurement is 50 Ω from 0.1 to 6 GHz

4 Measured Parameters

Power Gain $|S_{21}|^2, G_{ma} = f(f)$
 $V_{CC} = 2.75V, I_{tot-on} = 5.8mA$

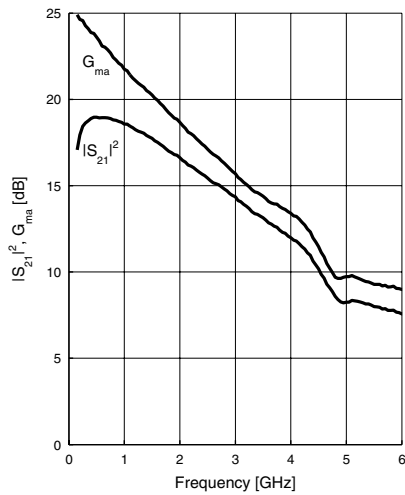

Off Gain $|S_{21}|^2 = f(f)$
 $V_{CC} = 2.75V, V_{OUT} = 2.75V, I_{tot-off} = 0.3mA$

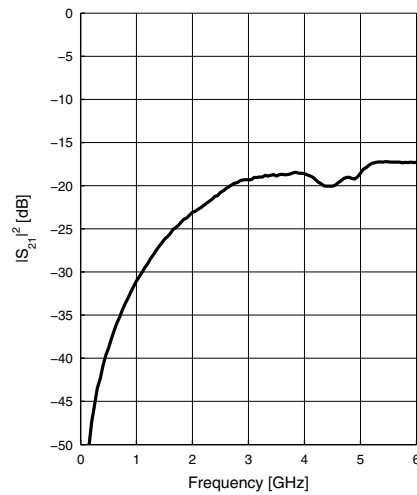

Reverse Isolation $|S_{12}| = f(f)$
 $V_{CC} = 2.75V, I_{tot-on} = 5.8mA$

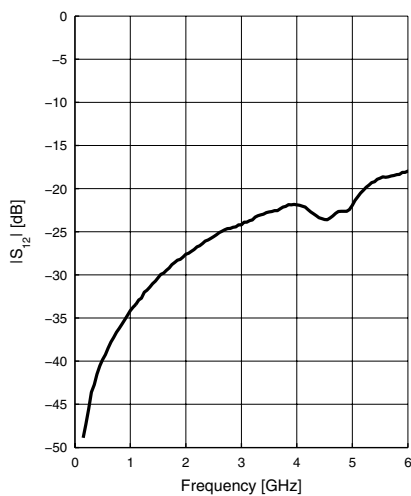

Matching $|S_{11}|, |S_{22}| = f(f)$
 $V_{CC} = 2.75V, I_{tot-on} = 5.8mA$

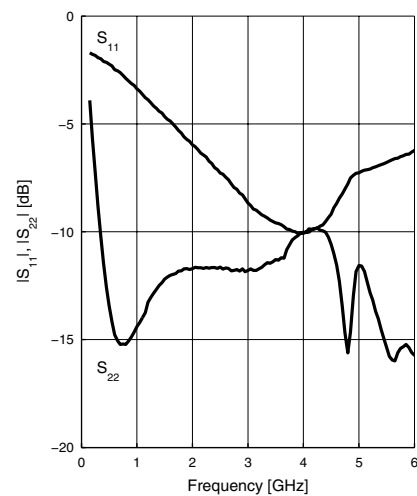

Measured Parameters

Stability $K, B_1 = f(f)$

$V_{CC} = 2.75V, I_{tot-on} = 5.8mA$

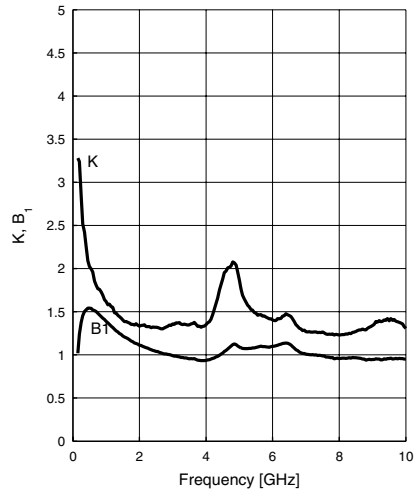

Noise Figure $F = f(f)$

$V_{CC} = 2.75V, I_{tot-on} = 5.8mA, Z_S = 50\Omega$

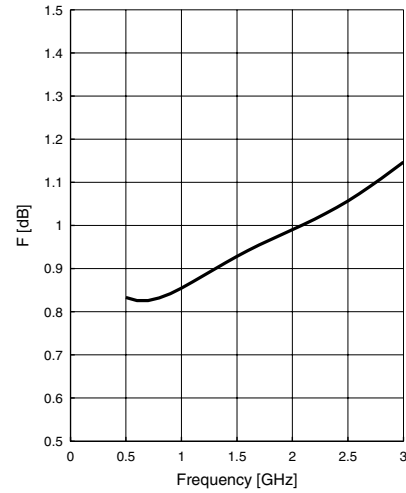

Device Current $I_{tot-on} = f(T_A, V_{CC})$

$V_{CC} = \text{parameter in V}$

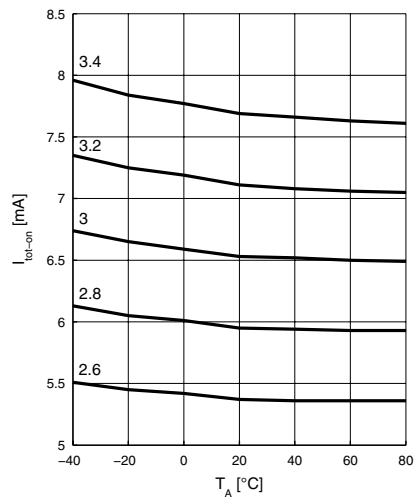

Device Current $I_{tot-on} = f(V_{CC}, T_A)$

$T_A = \text{parameter in } ^\circ C$

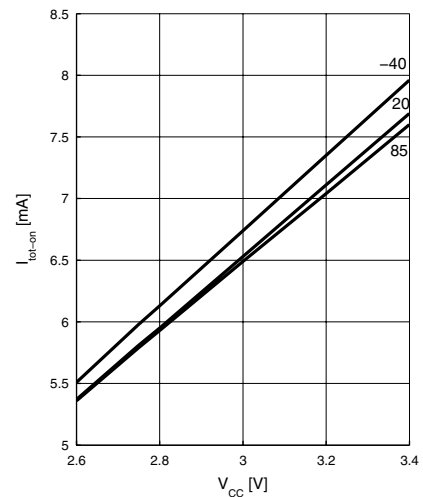

5 Package Information

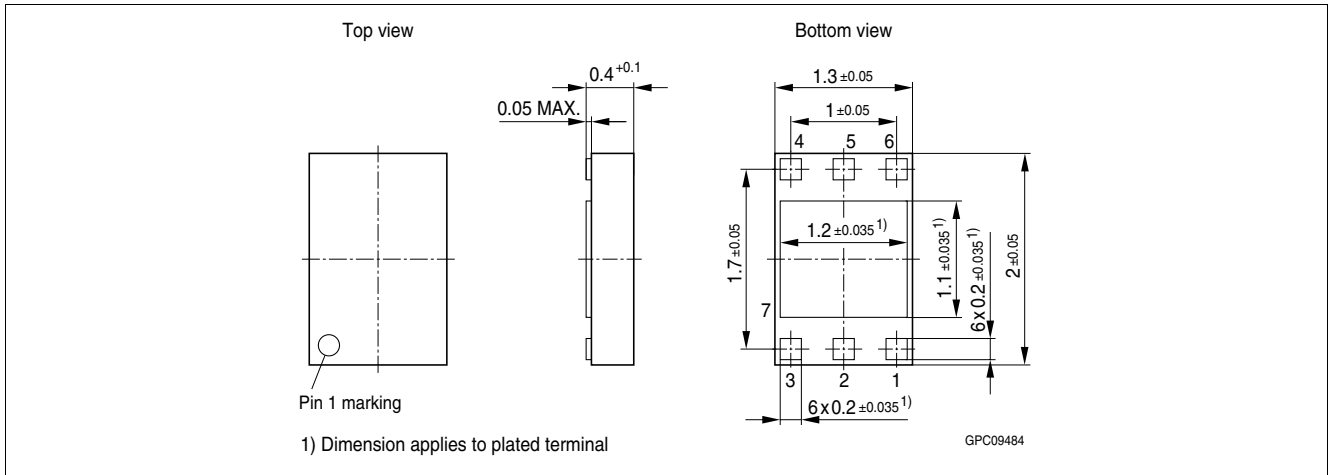

Figure 3 Package Outline TSLP-7-1

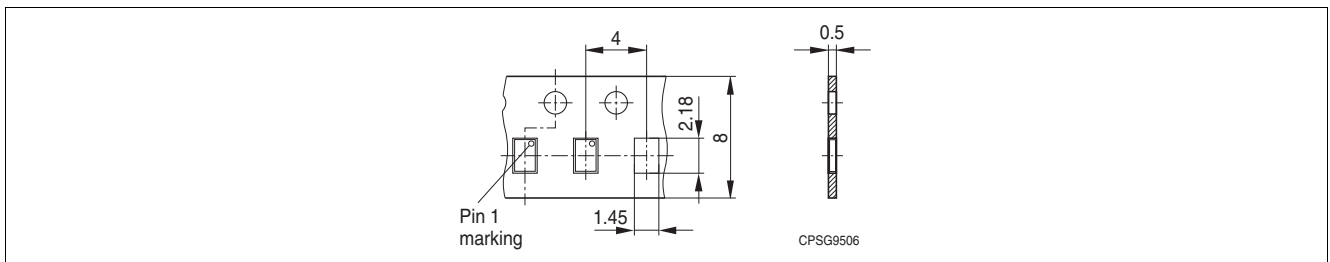

Figure 4 Tape for TSLP-7-1