



Chipsmall Limited consists of a professional team with an average of over 10 year of expertise in the distribution of electronic components. Based in Hongkong, we have already established firm and mutual-benefit business relationships with customers from,Europe,America and south Asia,supplying obsolete and hard-to-find components to meet their specific needs.

With the principle of "Quality Parts,Customers Priority,Honest Operation,and Considerate Service",our business mainly focus on the distribution of electronic components. Line cards we deal with include Microchip,ALPS,ROHM,Xilinx,Pulse,ON,Everlight and Freescale. Main products comprise IC,Modules,Potentiometer,IC Socket,Relay,Connector.Our parts cover such applications as commercial,industrial, and automotives areas.

We are looking forward to setting up business relationship with you and hope to provide you with the best service and solution. Let us make a better world for our industry!



## Contact us

Tel: +86-755-8981 8866 Fax: +86-755-8427 6832

Email & Skype: info@chipsmall.com Web: www.chipsmall.com

Address: A1208, Overseas Decoration Building, #122 Zhenhua RD., Futian, Shenzhen, China



## BGS12A

Tiny, but ESD-robust SPDT switch with no external components required



THE BGS12A is Infineon's first product in its new Radio Frequency (RF) switch family. The BGS12A is a general purpose Single-Pole, Double-Throw (SPDT) RF switch, designed for power levels of up to 20dBm, with a P-1dB above 30dBm.

### Product features

Manufactured using a unique RF-CMOS technology, this switch does not require external DC-blocking capacitors and the control logic is fully integrated. All interfaces are protected against Electrostatic Discharge (ESD) of at least 1.5kV HBM (Human Body Model). The BGS12A comes in a fine-pitch Wafer-Level Package (WLP), offering smallest size and height. It is ideal for use in low and medium-power applications up to 3GHz.

### Customer Values

- Cost and space saving by reduced BOM
- Improved yield due to less ESD failures during production
- 60% less PCB/LTCC space compared with smallest packaged product on the market
- Reduced filter effort due to low harmonic level

### Features

- Fine-pitch WLP with smallest dimensions at 0.79 x 0.54mm<sup>2</sup>
- ESD of at least 1.5kV HBM at all ports
- No external blocking capacitor required
- On-chip control logic
- Single control line
- Low harmonic distortion

### Applications

- RF modules
- Mobile phones
- Game consoles
- Data cards
- Tuners
- Remote Keyless Entry (RKE) systems

### Electrical key parameter of BGS12A

Frequency [GHz]	Insertion loss [dB]	Isolation [dB]	P-1dB [dBm]	2nd/3rd harmonic [dBc]
1.0	0.3	34	>30	-90
2.0	0.6	27	>30	-90

[www.infineon.com/RFswitches](http://www.infineon.com/RFswitches)

## Small Signal Discretes



Never stop thinking

## Application Examples

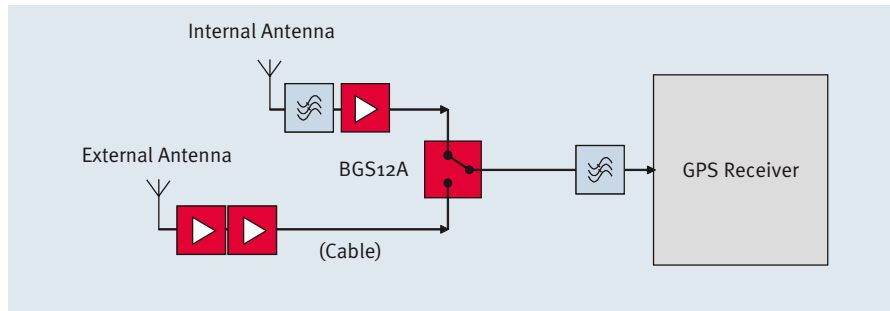

GPS receiver with 2nd external antenna

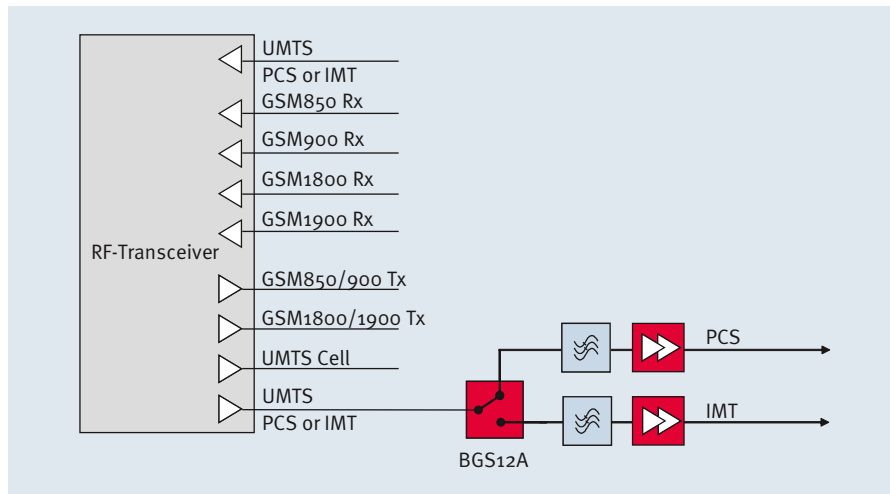

UMTS-multiband application with interstage switch

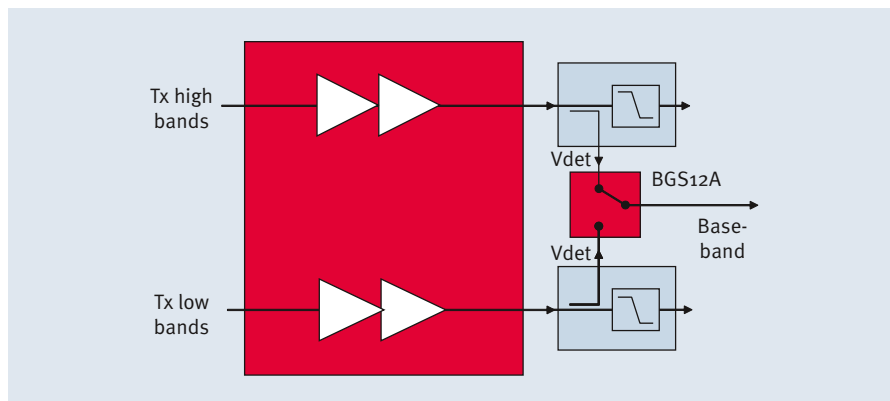

Power detection switch used in Dual Band Power Amplifier

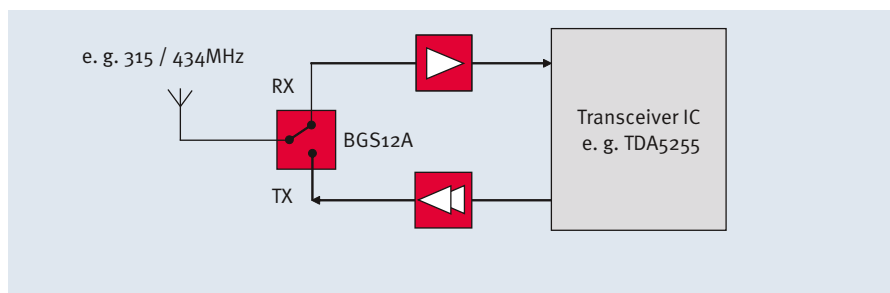

RKE / Car Alarm Transceiver Solution (KeyFob and Car Unit)

How to reach us:  
<http://www.infineon.com>

Published by  
**Infineon Technologies AG**  
 81726 Munich, Germany

© 2008 Infineon Technologies AG  
 All Rights Reserved.

### Legal Disclaimer

The information given in this Product Brief shall in no event be regarded as a guarantee of conditions or characteristics. With respect to any examples or hints given herein, any typical values stated herein and/or any information regarding the application of the device, Infineon Technologies hereby disclaims any and all warranties and liabilities of any kind, including without limitation, warranties of non-infringement of intellectual property rights of any third party.

### Information

For further information on technology, delivery terms and conditions and prices, please contact the nearest Infineon Technologies Office ([www.infineon.com](http://www.infineon.com)).

### Warnings

Due to technical requirements, components may contain dangerous substances. For information on the types in question, please contact the nearest Infineon Technologies Office.

Infineon Technologies components may be used in life-support devices or systems only with the express written approval of Infineon Technologies, if a failure of such components can reasonably be expected to cause the failure of that life-support device or system or to affect the safety or effectiveness of that device or system. Life support devices or systems are intended to be implanted in the human body or to support and/or maintain and sustain and/or protect human life. If they fail, it is reasonable to assume that the health of the user or other persons may be endangered.