



Chipsmall Limited consists of a professional team with an average of over 10 year of expertise in the distribution of electronic components. Based in Hongkong, we have already established firm and mutual-benefit business relationships with customers from,Europe,America and south Asia,supplying obsolete and hard-to-find components to meet their specific needs.

With the principle of “Quality Parts,Customers Priority,Honest Operation,and Considerate Service”,our business mainly focus on the distribution of electronic components. Line cards we deal with include Microchip,ALPS,ROHM,Xilinx,Pulse,ON,Everlight and Freescale. Main products comprise IC,Modules,Potentiometer,IC Socket,Relay,Connector.Our parts cover such applications as commercial,industrial, and automotives areas.

We are looking forward to setting up business relationship with you and hope to provide you with the best service and solution. Let us make a better world for our industry!



Contact us

Tel: +86-755-8981 8866 Fax: +86-755-8427 6832

Email & Skype: info@chipsmall.com Web: www.chipsmall.com

Address: A1208, Overseas Decoration Building, #122 Zhenhua RD., Futian, Shenzhen, China



BGS13SL9

Wideband RF SP3T Switch

Data Sheet

Revision 2.4, 2014-05-27

Edition May 27, 2014

**Published by
Infineon Technologies AG
81726 Munich, Germany**

**©2012 Infineon Technologies AG
All Rights Reserved.**

Legal Disclaimer

The information given in this document shall in no event be regarded as a guarantee of conditions or characteristics. With respect to any examples or hints given herein, any typical values stated herein and/or any information regarding the application of the device, Infineon Technologies hereby disclaims any and all warranties and liabilities of any kind, including without limitation, warranties of non-infringement of intellectual property rights of any third party.

Information

For further information on technology, delivery terms and conditions and prices, please contact the nearest Infineon Technologies Office (www.infineon.com).

Warnings

Due to technical requirements, components may contain dangerous substances. For information on the types in question, please contact the nearest Infineon Technologies Office.

Infineon Technologies components may be used in life-support devices or systems only with the express written approval of Infineon Technologies, if a failure of such components can reasonably be expected to cause the failure of that life-support device or system or to affect the safety or effectiveness of that device or system. Life support devices or systems are intended to be implanted in the human body or to support and/or maintain and sustain and/or protect human life. If they fail, it is reasonable to assume that the health of the user or other persons may be endangered.

Revision History

Previous Version: v2.3, 2014-02-13

Page	Subjects (major changes since last revision)
10	Updated Temperature range (Table 6)
13	Updated Tape Drawing for TSLP-9-3 (Figure 5)

Trademarks of Infineon Technologies AG

AURIX™, C166™, CanPAK™, CIPOS™, CIPURSE™, CoolGaN™, CoolMOS™, CoolSET™, CoolSiC™, CORECONTROL™, DAVE™, DI-POL™, EasyPIM™, EconoBRIDGE™, EconoDUAL™, EconoPACK™, EconoPIM™, EiceDRIVER™, eupec™, FCOS™, HITFET™, HybridPACK™, ISOFACE™, I²RF™, IsoPACK™, MIPAQ™, ModSTACK™, my-d™, NovalithIC™, OmniTune™, OptiMOS™, ORIGA™, OPTIGA™, PROFET™, PRO-SIL™, PRIMARION™, PrimePACK™, RASIC™, ReverSave™, SatRIC™, SIEGET™, SIPMOS™, SOLID FLASH™, SmartLEWIS™, TEMPFET™, thinQ!™, TriCore™, TRENCHSTOP™.

Other Trademarks

Advance Design System™ (ADS) of Agilent Technologies, AMBA™, ARM™, MULTI-ICE™, PRIMECELL™, REALVIEW™, THUMB™ of ARM Limited, UK. AUTOSAR™ is licensed by AUTOSAR development partnership. Bluetooth™ of Bluetooth SIG Inc. CAT-iq™ of DECT Forum. COLOSSUS™, FirstGPS™ of Trimble Navigation Ltd. EMV™ of EMVCo, LLC (Visa Holdings Inc.). EPCOS™ of Epcos AG. FLEXGO™ of Microsoft Corporation. FlexRay™ is licensed by FlexRay Consortium. HYPERTERMINAL™ of Hilgraeve Incorporated. IEC™ of Commission Electrotechnique Internationale. IrDA™ of Infrared Data Association Corporation. ISO™ of INTERNATIONAL ORGANIZATION FOR STANDARDIZATION. MATLAB™ of MathWorks, Inc. MAXIM™ of Maxim Integrated Products, Inc. MICROTEC™, NUCLEUS™ of Mentor Graphics Corporation. Mifare™ of NXP. MIPI™ of MIPI Alliance, Inc. MIPS™ of MIPS Technologies, Inc., USA. muRata™ of MURATA MANUFACTURING CO., MICROWAVE OFFICE™ (MWO) of Applied Wave Research Inc., OmniVision™ of OmniVision Technologies, Inc. Openwave™ Openwave Systems Inc. RED HAT™ Red Hat, Inc. RFMD™ RF Micro Devices, Inc. SIRIUS™ of Sirius Sattelite Radio Inc. SOLARIS™ of Sun Microsystems, Inc. SPANSION™ of Spansion LLC Ltd. Symbian™ of Symbian Software Limited. TAIYO YUDEN™ of Taiyo Yuden Co. TEAKLITE™ of CEVA, Inc. TEKTRONIX™ of Tektronix Inc. TOKO™ of TOKO KABUSHIKI KAISHA TA. UNIX™ of X/Open Company Limited. VERILOG™, PALLADIUM™ of Cadence Design Systems, Inc. VLYNQ™ of Texas Instruments Incorporated. VXWORKS™, WIND RIVER™ of WIND RIVER SYSTEMS, INC. ZETEX™ of Diodes Zetex Limited.

Last Trademarks Update 2012-12-13

Contents

1 Features	7
2 Product Description	7
3 Maximum Ratings	9
4 Operation Ranges	9
5 RF Characteristics	10
6 Pin Description and Package Outline	12

List of Figures

1	BGS13SL9 Block Diagram	8
2	Package Outline	12
3	Pin 1 Marking (top view)	13
4	Footprint TSLP-9-3	13
5	Tape Drawing for TSLP-9-3	13

List of Tables

1	Ordering Information	7
2	Truth Table	8
3	Maximum Ratings	9
4	Operation Ranges	9
5	RF Input Power	9
6	RF Characteristics	10
7	Mechanical Data	12
8	Pin Description	12

BGS13SL9 Wideband RF SP3T Switch

1 Features

- 3 high-linearity TRx paths with power handling capability of up to 30 dBm
- High switching speed, ideal for WLAN and Bluetooth applications
- All ports fully bi-directional
- No decoupling capacitors required if no DC applied on RF lines
- Low insertion loss
- Low harmonic generation
- High port-to-port-isolation
- 0.1 to 3 GHz coverage
- High ESD robustness
- On-chip control logic
- Very small leadless and halogen free package TSLP-9-3 (1.15x1.15mm²) with super low height of 0.31mm
- RoHS compliant package

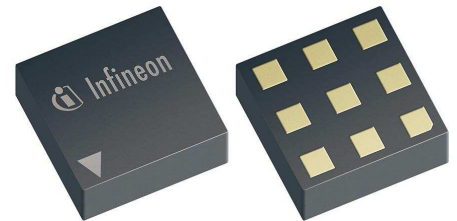

2 Product Description

The BGS13SL9 RF MOS switch is specifically designed for WLAN and Bluetooth applications. Any of the 3 ports can be used as termination of the diversity antenna handling up to 30 dBm.

This SP3T offers low insertion loss and high robustness against interferer signals at the antenna port and low harmonic generation in termination mode. The on-chip controller integrates CMOS logic and level shifters, driven by control inputs from 1.5 V to V_{dd} . The BGS13SL9 RF Switch is manufactured in Infineon's patented MOS technology, offering the performance of GaAs with the economy and integration of conventional CMOS including the inherent higher ESD robustness. The device has a very small size of only 1.15 x 1.15 mm² and a maximum height of 0.31 mm.

No decoupling capacitors are required in typical applications as long as no DC is applied to any RF port.

Table 1: Ordering Information

Type	Package	Marking
BGS13SL9	TSLP-9-3	AA

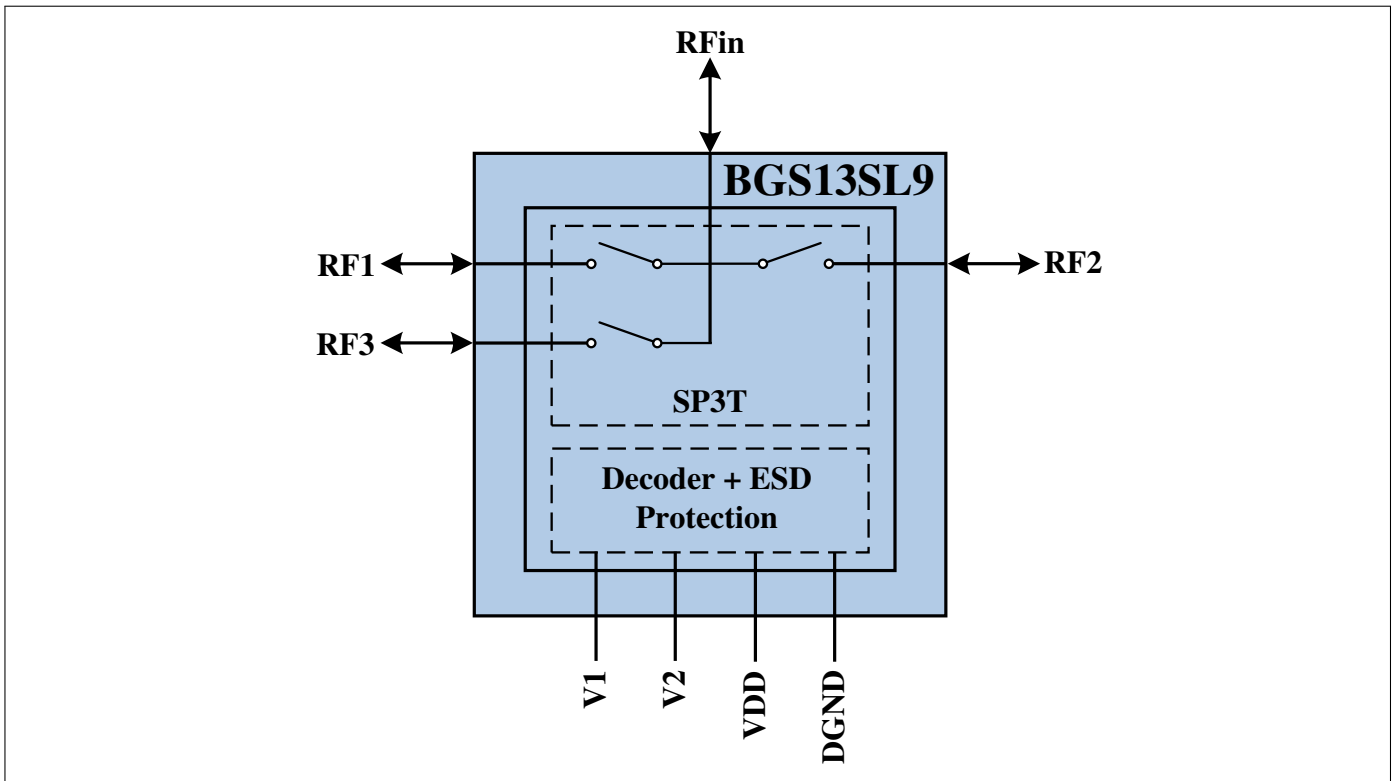

Figure 1: BGS13SL9 Block Diagram

Table 2: Truth Table

Switched Paths	V1	V2
Isolation / All Paths Open	0	0
RFin - RF1	1	0
RFin - RF2	0	1
RFin - RF3	1	1

3 Maximum Ratings

Table 3: Maximum Ratings at $T_A = 25\text{ }^\circ\text{C}$, unless otherwise specified

Parameter	Symbol	Values			Unit	Note / Test Condition
		Min.	Typ.	Max.		
Supply Voltage	V_{DD}	-0.5	–	5.5	V	–
Maximum DC-Voltage on Other Pins	V_{DC}	-0.3	–	3.6	V	–
Storage Temperature Range	T_{STG}	-55	–	150	$^\circ\text{C}$	–
RF Input Power	P_{RF_TRx}	–	–	32	dBm	–
Junction Temperature	T_j	–	–	125	$^\circ\text{C}$	–
ESD Capability						
Human Body Model ¹⁾	V_{ESD_HBM}	–1	–	+1	kV	–
ESD Capability RFin Port ²⁾	V_{ESD_RFin}	–8	–	+8	kV	RFin versus GND, with 27 nH shunt inductor

¹⁾ Human Body Model ANSI/ESDA/JEDEC JS-001-2012 ($R = 1.5\text{ k}\Omega$, $C = 100\text{ pF}$).

²⁾ IEC 61000-4-2 ($R = 330\text{ }\Omega$, $C = 150\text{ pF}$), contact discharge.

Attention:

Stresses above the max. values listed here may cause permanent damage to the device. Exposure to absolute maximum rating conditions for extended periods may affect device reliability. Maximum ratings are absolute ratings; exceeding only one of these values may cause irreversible damage to the integrated circuit.

4 Operation Ranges

Table 4: Operation Ranges

Parameter	Symbol	Values			Unit	Note / Test Condition
		Min.	Typ.	Max.		
Ambient Temperature	T_A	-40	25	85	$^\circ\text{C}$	–
RF Frequency	f	0.1	–	3	GHz	–
Supply Voltage	V_{DD}	2.3	–	3.6	V	–
Control Voltage Low	V_{Ctrl_L}	-0.3	–	0.3	V	–
Control Voltage High	V_{Ctrl_H}	1.5	–	V_{DD}	V	$V_{DD} < 3.3\text{ V}$

Table 5: RF Input Power

Parameter	Symbol	Values			Unit	Note / Test Condition
		Min.	Typ.	Max.		
RF Input Power (50 Ω)	P_{In}	–	–	30	dBm	–

5 RF Characteristics

Table 6: RF Characteristics

Test Conditions (unless otherwise specified):

- Terminating port impedance: $Z_0 = 50 \Omega$
- Temperature range: $T_A = -40 \dots +85 \text{ }^\circ\text{C}$
- Supply voltage: $V_{DD} = 2.3 \dots 3.6 \text{ V}$
- Input power: $P_{IN} = 0 \text{ dBm}$

Parameter	Symbol	Values			Unit	Note / Test Condition
		Min.	Typ.	Max.		
Insertion Loss						
All RF Ports	IL	0.24	0.35	0.55	dB	824 - 915 MHz
		0.28	0.44	0.65	dB	1710 - 1910 MHz
		0.30	0.50	0.80	dB	2170 - 2500 MHz
		0.35	0.54	0.90	dB	2700 MHz
Insertion Loss¹						
All RF Ports	IL	0.30	0.35	0.40	dB	824 - 915 MHz
		0.37	0.44	0.50	dB	1710 - 1910 MHz
		0.40	0.50	0.60	dB	2170 - 2500 MHz
		0.44	0.54	0.70	dB	2700 MHz
Return Loss						
All RF Ports	RL	21	25	28	dB	824 - 915 MHz
		15	18	24	dB	1710 - 1910 MHz
		12	16	22	dB	2170 - 2500 MHz
		12	14	20	dB	2700 MHz
Isolation						
RFin to RF1/RF2/RF3	ISO_{In-RFx}	32	37	44	dB	824 - 915 MHz
		22	27	33	dB	1710 - 1910 MHz
		19	24	29	dB	2170 - 2500 MHz
		18	22	27	dB	2700 MHz
RF1 to RF2 / RF2 to RF1 RF1 to RF3 / RF3 to RF1 RF2 to RF3 / RF3 to RF2	$ISO_{Port-Port}$	32	42	49	dB	824 - 915 MHz
		24	31	36	dB	1710 - 1910 MHz
		21	27	32	dB	2170 - 2500 MHz
		20	26	31	dB	2700 MHz

¹ $T_A = +25 \text{ }^\circ\text{C}$, $V_{DD} = 3 \text{ V}$

Parameter	Symbol	Values			Unit	Note / Test Condition
		Min.	Typ.	Max.		
Harmonic Generation up to 12.75 GHz						
Any Path	P_{Harm}	–	-80	-70	dBc	$P_{in} = 27 \text{ dBm}$, 50 % Duty Cycle, 50Ω
Intermodulation Distortion in Rx Band^{1,2}						
IMD2	$IMD2$	–	-110	-105	dBm	Tx = 10 dBm, Interferer = -15 dBm, 50Ω
IMD3	$IMD3$	–	-115	-105	dBm	
Switching Time and Current Consumption						
RF Rise Time	$t_{10\%-90\%}$	–	23	90	ns	10% - 90% of RF Signal
Ctrl to RF Time	$t_{Ctrl-RF}$	–	95	250	ns	50% of Ctrl Signal to 90% of RF Signal
Supply Current	I_{DD}	–	140	270	μA	–
Control Current	I_{Ctrl}	–	1	10	μA	–

Note: All electrical characteristics are measured with all RF ports terminated by 50Ω loads.

¹ $T_A = +25^\circ\text{C}$, $V_{DD} = 3\text{V}$

² With external shunt L

6 Pin Description and Package Outline

Table 7: Mechanical Data

Parameter	Symbol	Value	Unit
X-Dimension	X	1.15 ± 0.05	mm
Y-Dimension	Y	1.15 ± 0.05	mm
Size	Size	1.3225	mm ²
Height	H	$0.31 +0.01/-0.02$	mm

Table 8: Pin Description

Pin No.	Name	Pin Type	Buffer Type	Function
1	V1	I		Control Pin 1
2	RF3	I/O		RF-Port 3
3	RF1	I/O		RF-Port 1
4	RFin	I/O		RF Input
5	RF2	I/O		RF-Port 2
6	DGND	GND		Digital Ground
7	VDD	PWR		Power Supply
8	V2	I		Control Pin 2
9	GND	GND		Ground

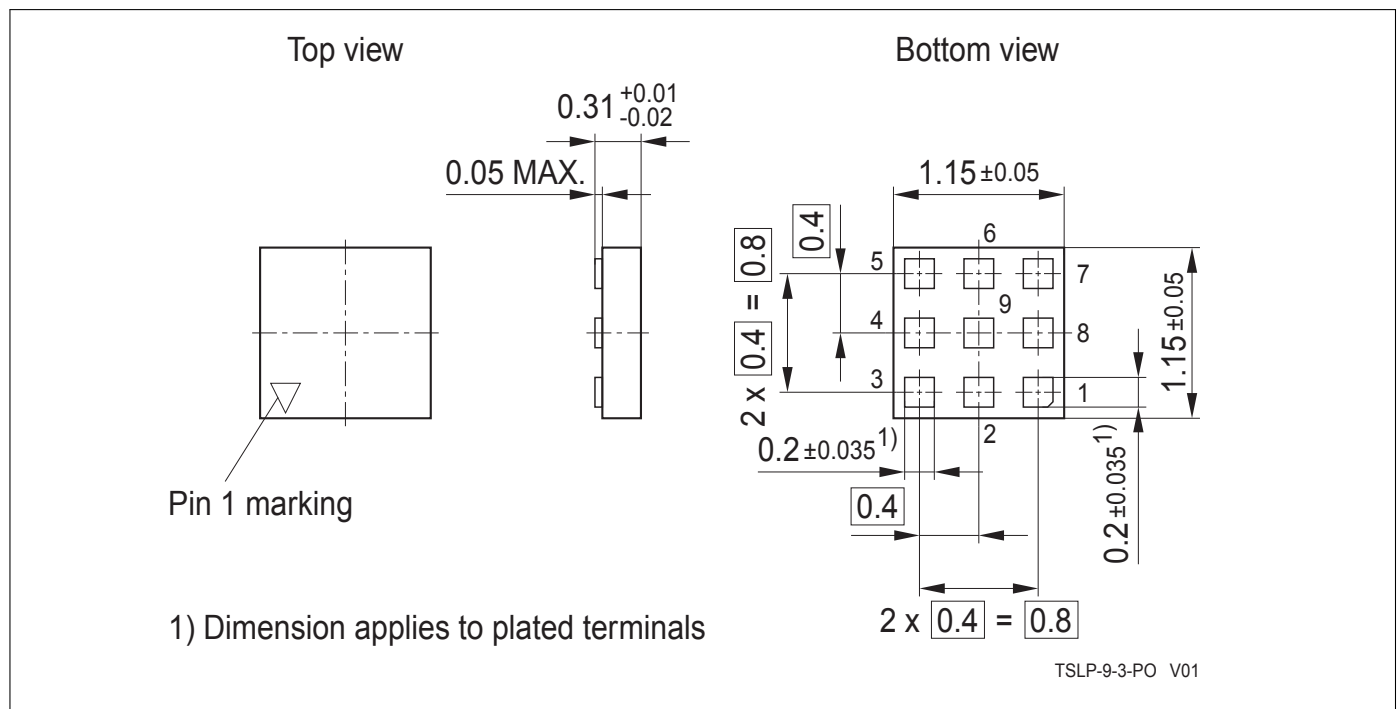

Figure 2: Package Outline

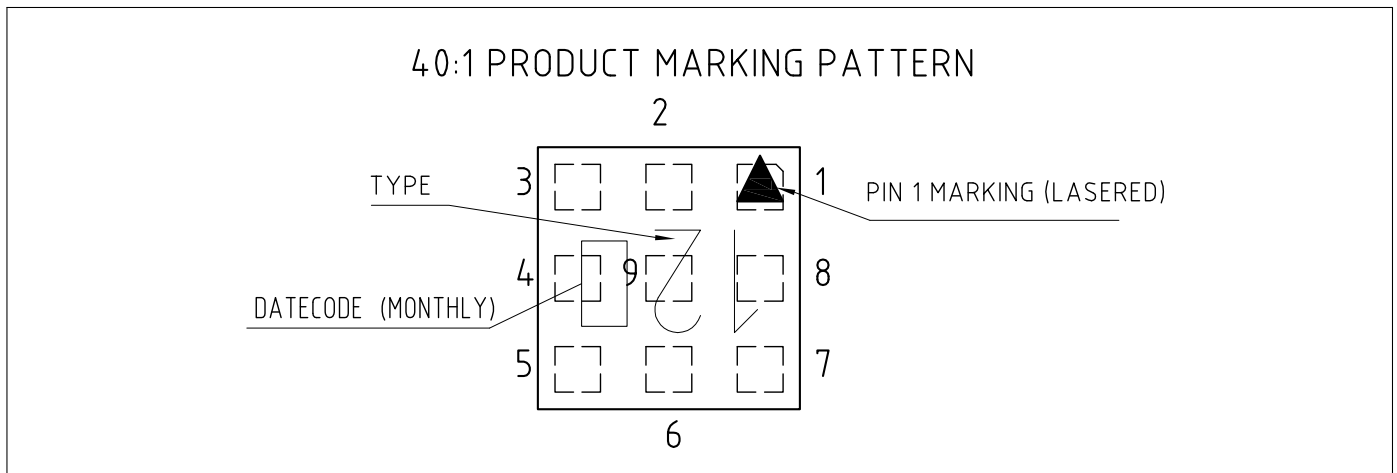

Figure 3: Pin 1 Marking (top view)

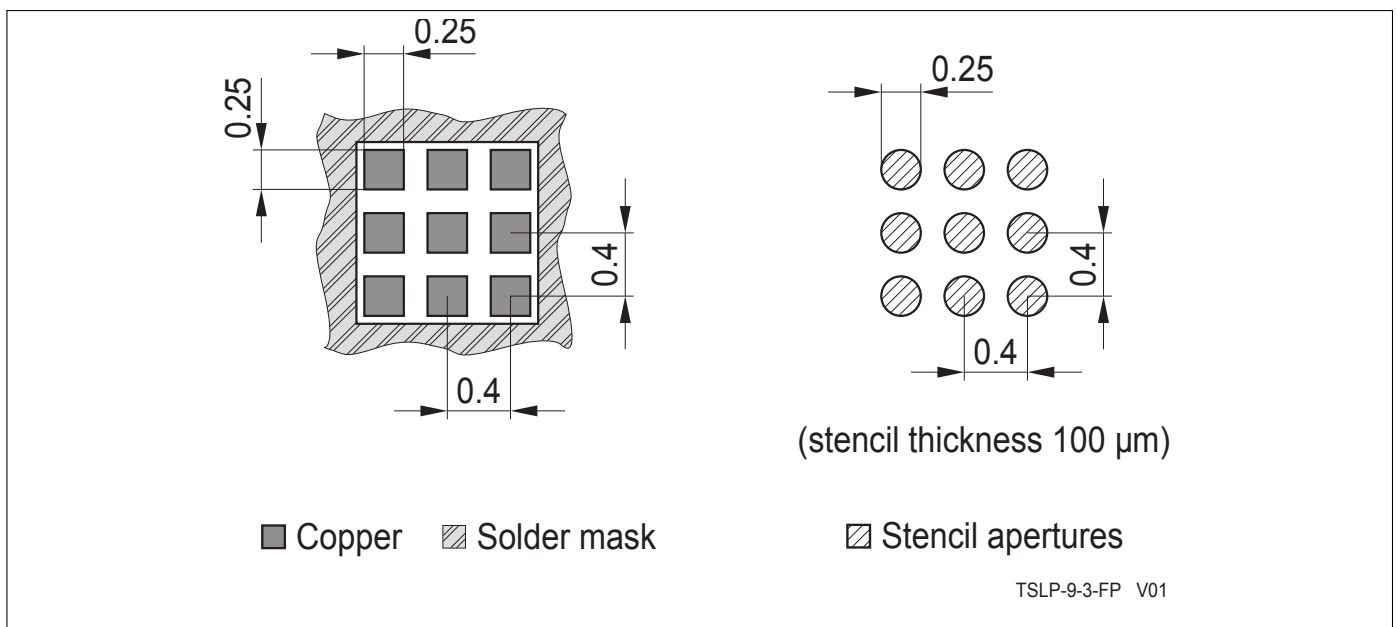

Figure 4: Footprint TSLP-9-3

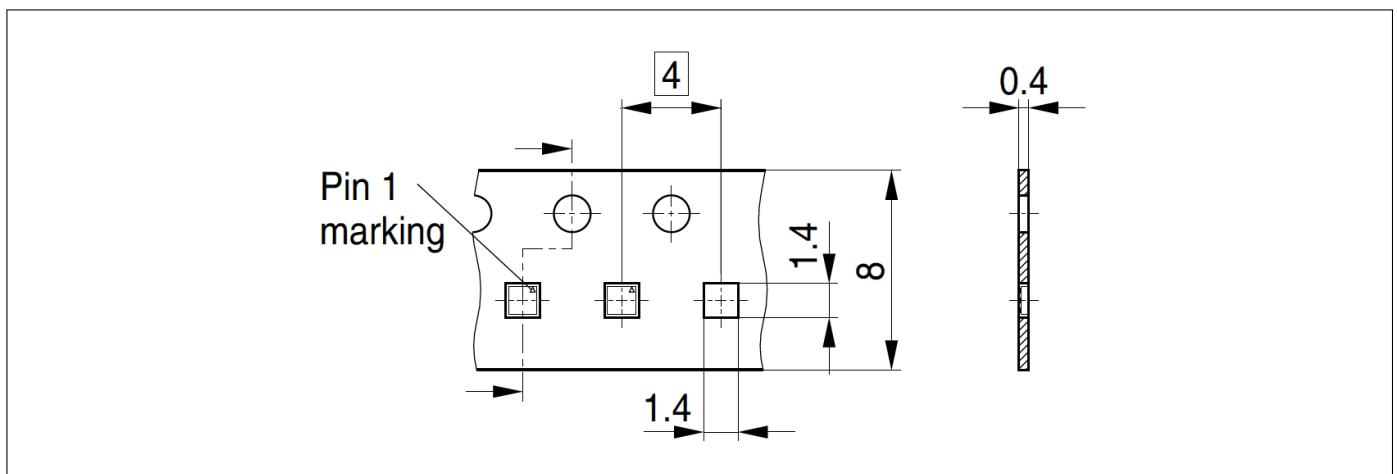

Figure 5: Tape Drawing for TSLP-9-3

www.infineon.com

Published by Infineon Technologies AG