



Chipsmall Limited consists of a professional team with an average of over 10 year of expertise in the distribution of electronic components. Based in Hongkong, we have already established firm and mutual-benefit business relationships with customers from,Europe,America and south Asia,supplying obsolete and hard-to-find components to meet their specific needs.

With the principle of “Quality Parts,Customers Priority,Honest Operation,and Considerate Service”,our business mainly focus on the distribution of electronic components. Line cards we deal with include Microchip,ALPS,ROHM,Xilinx,Pulse,ON,Everlight and Freescale. Main products comprise IC,Modules,Potentiometer,IC Socket,Relay,Connector.Our parts cover such applications as commercial,industrial, and automotives areas.

We are looking forward to setting up business relationship with you and hope to provide you with the best service and solution. Let us make a better world for our industry!



Contact us

Tel: +86-755-8981 8866 Fax: +86-755-8427 6832

Email & Skype: info@chipsmall.com Web: www.chipsmall.com

Address: A1208, Overseas Decoration Building, #122 Zhenhua RD., Futian, Shenzhen, China



BGS22WL10

DPDT (Dual-Pole / Double-Throw) Differential RF Switch

Data Sheet

Revision 1.7 - June 1, 2015

Edition June 1, 2015

**Published by
Infineon Technologies AG
81726 Munich, Germany**

**©2011 Infineon Technologies AG
All Rights Reserved.**

Legal Disclaimer

The information given in this document shall in no event be regarded as a guarantee of conditions or characteristics. With respect to any examples or hints given herein, any typical values stated herein and/or any information regarding the application of the device, Infineon Technologies hereby disclaims any and all warranties and liabilities of any kind, including without limitation, warranties of non-infringement of intellectual property rights of any third party.

Information

For further information on technology, delivery terms and conditions and prices, please contact the nearest Infineon Technologies Office (www.infineon.com).

Warnings

Due to technical requirements, components may contain dangerous substances. For information on the types in question, please contact the nearest Infineon Technologies Office.

Infineon Technologies components may be used in life-support devices or systems only with the express written approval of Infineon Technologies, if a failure of such components can reasonably be expected to cause the failure of that life-support device or system or to affect the safety or effectiveness of that device or system. Life support devices or systems are intended to be implanted in the human body or to support and/or maintain and sustain and/or protect human life. If they fail, it is reasonable to assume that the health of the user or other persons may be endangered.

Revision History

Previous Version: v1.6, May 27, 2014

Page	Subjects (major changes since last revision)
9	Updated Maximum Ratings (Table 3)

Trademarks of Infineon Technologies AG

AURIX™, BlueMoon™, COMNEON™, C166™, CROSSAVE™, CanPAK™, CIPOS™, CoolMOS™, CoolSET™, CORECONTROL™, DAVE™, EasyPIM™, EconoBRIDGE™, EconoDUAL™, EconoPACK™, EconoPIM™, EiceDRIVER™, EUPEC™, FCOS™, HITFET™, HybridPACK™, ISOFACE™, I²RF™, IsoPACK™, MIPAQ™, ModSTACK™, my-d™, NovalithIC™, OmniTune™, OptiMOS™, ORIGA™, PROFET™, PRO-SIL™, PRIMARION™, PrimePACK™, RASIC™, ReverSave™, SatRIC™, SIEGET™, SINDRION™, SMARTi™, SmartLEWIS™, TEMPFET™, thinQ!™, TriCore™, TRENCHSTOP™, X-GOLD™, XMM™, X-PMU™, XPOSYS™.

Other Trademarks

Advance Design System™ (ADS) of Agilent Technologies, AMBA™, ARM™, MULTI-ICE™, PRIMECELL™, REALVIEW™, THUMB™ of ARM Limited, UK. AUTOSAR™ is licensed by AUTOSAR development partnership. Bluetooth™ of Bluetooth SIG Inc. CAT-iq™ of DECT Forum. COLOSSUS™, FirstGPS™ of Trimble Navigation Ltd. EMV™ of EMVCo, LLC (Visa Holdings Inc.). EPCOS™ of Epcos AG. FLEXGO™ of Microsoft Corporation. FlexRay™ is licensed by FlexRay Consortium. HYPERTERMINAL™ of Hilgraeve Incorporated. IEC™ of Commission Electrotechnique Internationale. IrDA™ of Infrared Data Association Corporation. ISO™ of INTERNATIONAL ORGANIZATION FOR STANDARDIZATION. MATLAB™ of MathWorks, Inc. MAXIM™ of Maxim Integrated Products, Inc. MICROTEC™, NUCLEUS™ of Mentor Graphics Corporation. Mifare™ of NXP. MIPI™ of MIPI Alliance, Inc. MIPS™ of MIPS Technologies, Inc., USA. muRata™ of MURATA MANUFACTURING CO., MICROWAVE OFFICE™ (MWO) of Applied Wave Research Inc., OmniVision™ of OmniVision Technologies, Inc. Openwave™ Openwave Systems Inc. RED HAT™ Red Hat, Inc. RFMD™ RF Micro Devices, Inc. SIRIUS™ of Sirius Sattelite Radio Inc. SOLARIS™ of Sun Microsystems, Inc. SPANSION™ of Spansion LLC Ltd. Symbian™ of Symbian Software Limited. TAIYO YUDEN™ of Taiyo Yuden Co. TEAKLITE™ of CEVA, Inc. TEKTRONIX™ of Tektronix Inc. TOKO™ of TOKO KABUSHIKI KAISHA TA. UNIX™ of X/Open Company Limited. VERILOG™, PALLADIUM™ of Cadence Design Systems, Inc. VLYNQ™ of Texas Instruments Incorporated. VXWORKS™, WIND RIVER™ of WIND RIVER SYSTEMS, INC. ZETEX™ of Diodes Zetex Limited.

Last Trademarks Update 2010-06-09

Contents

1 Features	7
2 Product Description	7
3 Maximum Ratings	9
4 Operation Ranges	9
5 RF Characteristics	10
6 Package Outline and Pin Configuration	11

List of Figures

1	BGS22WL10 block diagram	8
2	Marking Layout (top view)	11
3	TSLP-10-1 Package Outline (top, side and bottom view)	12
4	Footprint TSLP-10-1	13
5	Tape and Reel Dimensions for TSLP-10-1	13

List of Tables

1	Ordering Information	7
2	Truth Table	8
3	Maximum Ratings	9
4	Operation Ranges	9
5	RF Input Power	9
6	RF Characteristics	10
7	Pin Configuration	11
8	Mechanical Data	12

BGS22WL10 DPDT (Dual-Pole / Double-Throw) Differential RF Switch

1 Features

- DPDT (Dual-Pole / Double-Throw) differential RF switch
- Frequency range: 0.1 - 3 GHz
- High signal power up to 30 dBm
- Supply voltage 2.3 - 3.6 V
- Small package size of 1.55 x 1.15 mm²
- No decoupling capacitors required if no DC applied
- RoHS compliant package



2 Product Description

The BGS22WL10 is a DPDT (Dual-Pole / Double Throw) RF switch which combines two differential signals into one differential output or splits one differential signal into two separate differential lines. The parallel paths of the switch are controlled simultaneously through the same signals. The switch is designed to operate in battery powered applications with a supply voltage range of 2.4 - 3.6 V. The highly symmetric design ensures best phase- and amplitude accuracy.

A typical application is to combine two Rx paths in a mobile cellular device after the Rx filters or duplexers into one input to the transceiver IC. The IC can also be used for a wide variety of applications switching balanced signals in a frequency range of 0.1 - 3 GHz. The RF switch is packaged in a standard RoHS compliant TSLP-10-1 package with a small outline of only 1.55 x 1.15 mm².

No decoupling capacitors are required in typical applications as long as no DC is applied to any RF port.

Table 1: Ordering Information

Type	Package	Marking
BGS22WL10	TSLP-10-1	22W

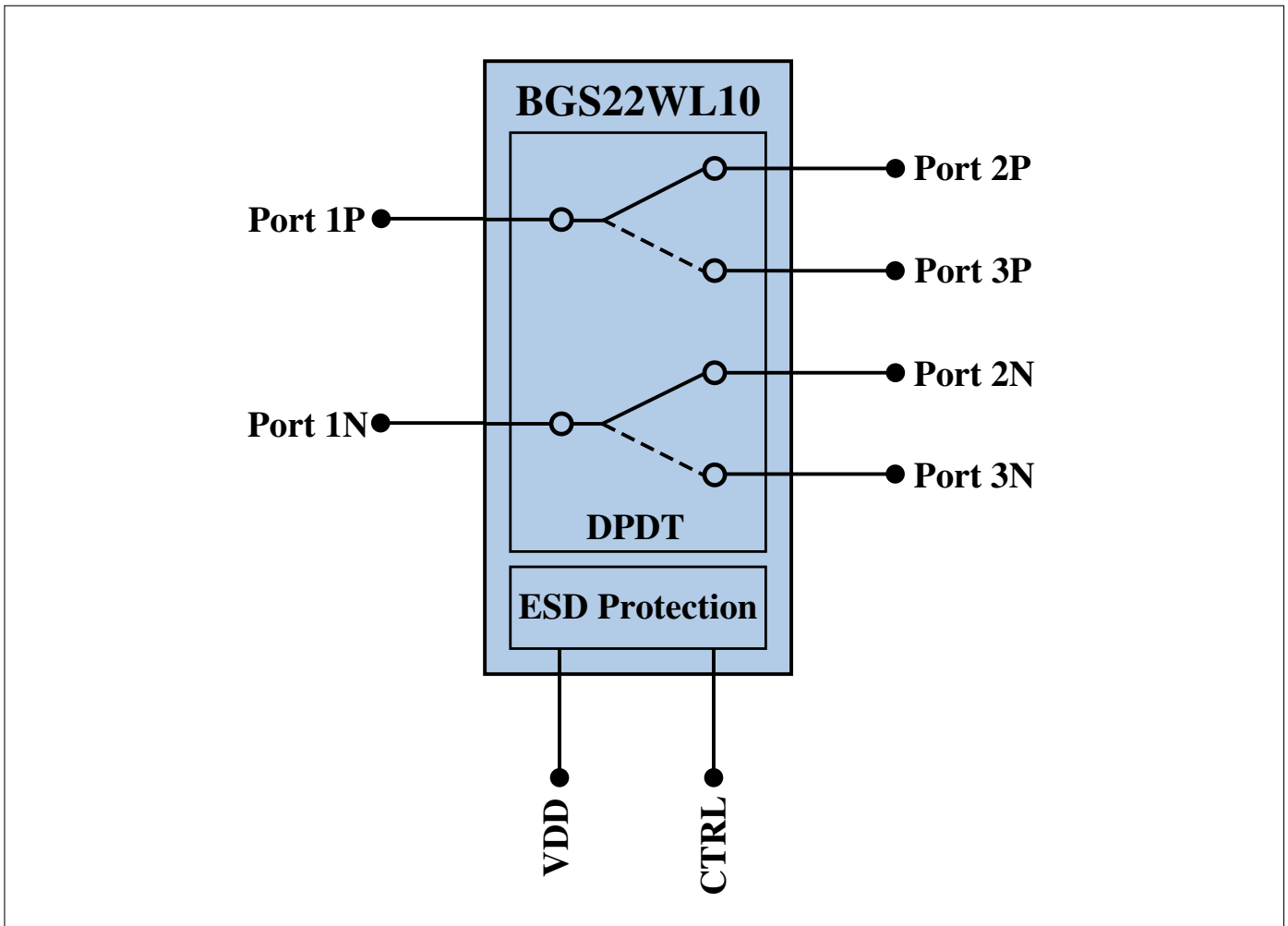

Figure 1: BGS22WL10 block diagram

Table 2: Truth Table

Pin No.	CTRL
Port 1 to Port 2	0
Port 1 to Port 3	1

3 Maximum Ratings

Table 3: Maximum Ratings at $T_A = 25\text{ °C}$, unless otherwise specified

Parameter	Symbol	Values			Unit	Note / Test Condition
		Min.	Typ.	Max.		
Supply voltage	V_{DD}	-0.5	–	5.5	V	–
Control voltage	V_{Ctrl}	-0.3	–	3.6	V	–
Storage temperature range	T_{STG}	-55	–	150	°C	–
RF input power	P_{In}	–	–	+32	dBm	–
ESD capability Human Body Model	V_{ESD_HBM}	1000	–	–	V	–
Junction temperature	T_j	–	–	125	°C	–
Thermal resistance junction - soldering point	R_{thJS}	–	–	43	K/W	–

Attention:

Stresses above the max. values listed here may cause permanent damage to the device. Exposure to absolute maximum rating conditions for extended periods may affect device reliability. Maximum ratings are absolute ratings; exceeding only one of these values may cause irreversible damage to the integrated circuit.

4 Operation Ranges

Table 4: Operation Ranges

Parameter	Symbol	Values			Unit	Note / Test Condition
		Min.	Typ.	Max.		
Supply Voltage	V_{DD}	2.3	–	3.6	V	–
Control Voltage Low	V_{Ctrl_L}	-0.3	–	0.4	V	–
Control Voltage High	V_{Ctrl_H}	1.2	–	V_{DD}	V	–
RF frequency	f_{RF}	0.1	–	–	GHz	–
Ambient Temperature	T_A	-40	25	85	°C	–

Table 5: RF Input Power

Parameter	Symbol	Values			Unit	Note / Test Condition
		Min.	Typ.	Max.		
RF Input Power (50Ω)	P_{In}	–	–	30	dBm	–

5 RF Characteristics

Table 6: RF Characteristics:

 Terminating port impedance: $Z_0 = 50 \Omega$

Measurement conditions unless otherwise specified:

 $T_A = 25 \text{ }^\circ\text{C}$, $P_{IN} = 0 \text{ dBm}$, Supply Voltage $V_{DD} = 2.3 - 3.6 \text{ V}$

Parameter	Symbol	Values			Unit	Note / Test Condition
		Min.	Typ.	Max.		
Insertion Loss - Typical Conditions: $T_A = 25 \text{ }^\circ\text{C}$, $V_{DD} = 3 \text{ V}$						
	IL	0.30	0.34	0.39	dB	824 - 915 MHz
		0.37	0.40	0.46	dB	1710 - 1910 MHz
		0.43	0.48	0.59	dB	2170 - 2690 MHz
Insertion Loss - Min/Max Conditions: $T_A = -40 \dots +85 \text{ }^\circ\text{C}$, $V_{DD} = 2.3 \dots 3.6 \text{ V}$						
	IL	0.23	0.34	0.54	dB	824 - 915 MHz
		0.27	0.40	0.58	dB	1710 - 1910 MHz
		0.31	0.48	0.75	dB	2170 - 2690 MHz
Return Loss - Min/Max Conditions: $T_A = -40 \dots +85 \text{ }^\circ\text{C}$, $V_{DD} = 2.3 \dots 3.6 \text{ V}$						
	RL	25	27	35	dB	824 - 915 MHz
		22	26	30	dB	1710 - 1910 MHz
		16	22	25	dB	2170 - 2690 MHz
Isolation¹						
	ISO	32	38	44	dB	824 - 915 MHz
		25	30	37	dB	1710 - 1910 MHz
		22	28	33	dB	2170 - 2690 MHz
P0.1 dB Compression Point						
	$P_{0.1dB}$	33	34	35	dBm	1000 MHz
Harmonic Generation up to 12.75 GHz						
Any path	P_{Harm}	80	85	95	dBc	27 dBm, 50Ω, 25 °C, 25 % duty cycle
Intermodulation Distortion in Rx Band						
IMD2_Low ²	P_{IMD2_L}	-125	-115	-105	dBm	Tx = 15 dBm, Interferer = -15 dBm
IMD3	P_{IMD3}	-125	-115	-110	dBm	Tx = 10 dBm, Interferer = -15 dBm
IMD2_High	P_{IMD2_H}	-125	-115	-110	dBm	Tx = 10 dBm, Interferer = -15 dBm
Switching Time and Current Consumption						
RF Rise Time	$t_{10\%-90\%}$	–	250	–	ns	10% - 90% of RF Signal ($V_{DD} = 3 \text{ V}$)
Ctrl to RF Time	$t_{Ctrl-RF}$	–	600	–	ns	50% of Ctrl Signal to 90% of RF Signal ($V_{DD} = 3 \text{ V}$)
Supply Current	I_{DD}	70	120	190	μA	Current at $T_A = 25 \text{ }^\circ\text{C}$
Phase Error						
Between any two paths	Ph_{Err}	0.3	0.5	0.7	Deg.	27 dBm, 50Ω, 25 °C, 25 % duty cycle

Note: All electrical characteristics are measured with all RF ports terminated in 50 Ω.

¹ Isolation values are not dependent on supply voltage and temperature as long as operated in the specified operation range.

² With external shunt inductor.

6 Package Outline and Pin Configuration

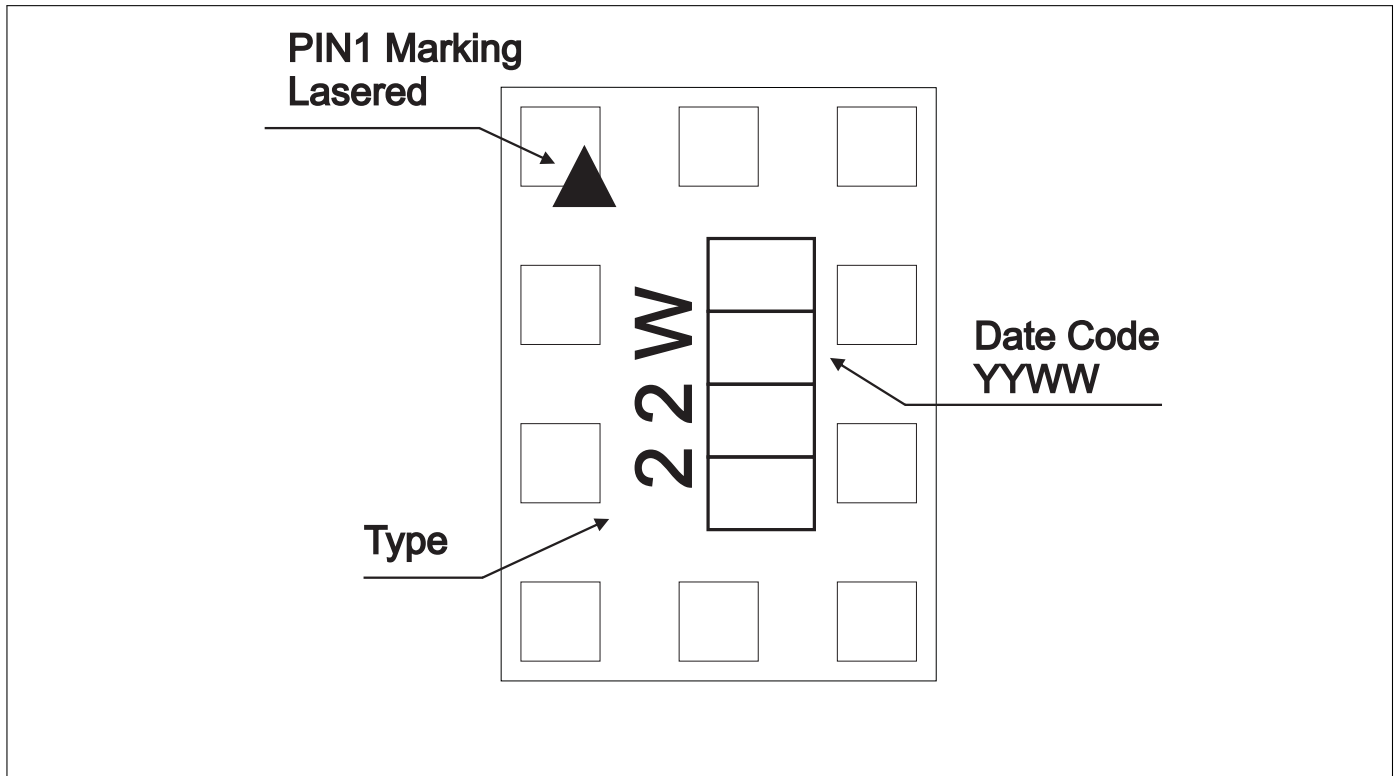

Figure 2: Marking Layout (top view)

Table 7: Pin Configuration

Pin No.	Name	Pin Type	Buffer Type	Function
1	Port 3P			Differential Output P of Port 3
2	GND			Ground Pin
3	GND			Ground Pin
4	Port 2N			Differential Output N of Port 2
5	Port 2P			Differential Output P of Port 2
6	CTRL			Control Voltage
7	Port 1P			Differential Input P of Port 1
8	Port 1N			Differential Input N of Port 1
9	VDD			Supply Voltage
10	Port 3N			Differential Output N of Port 3

Table 8: Mechanical Data

Parameter	Symbol	Value	Unit
Package X-Dimension	X	1.55 ± 0.05	mm
Package Y-Dimension	Y	1.15 ± 0.05	mm
Package Area	A	1.783	mm ²
Package Height	H	0.39 +0.01/-0.03	mm

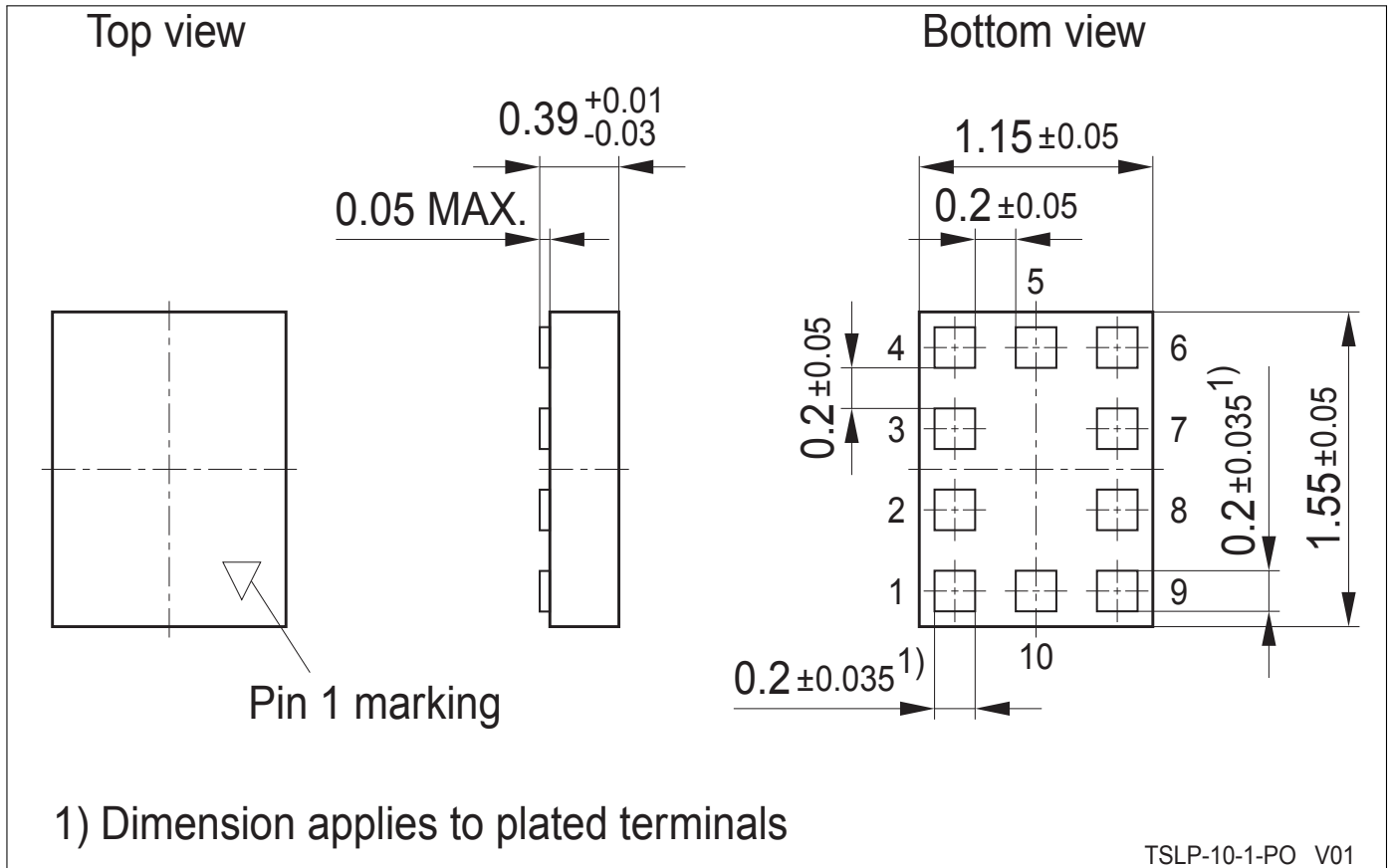

Figure 3: TSLP-10-1 Package Outline (top, side and bottom view)

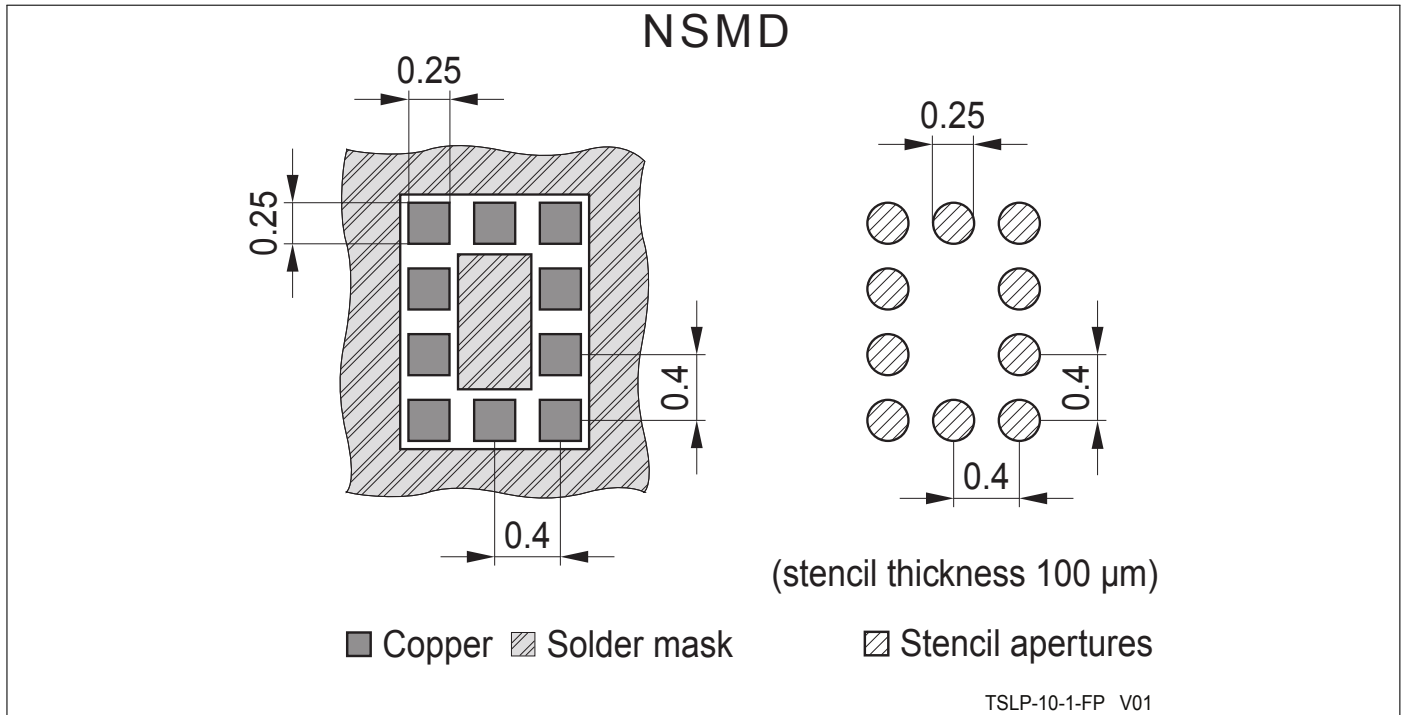

Figure 4: Footprint TSLP-10-1

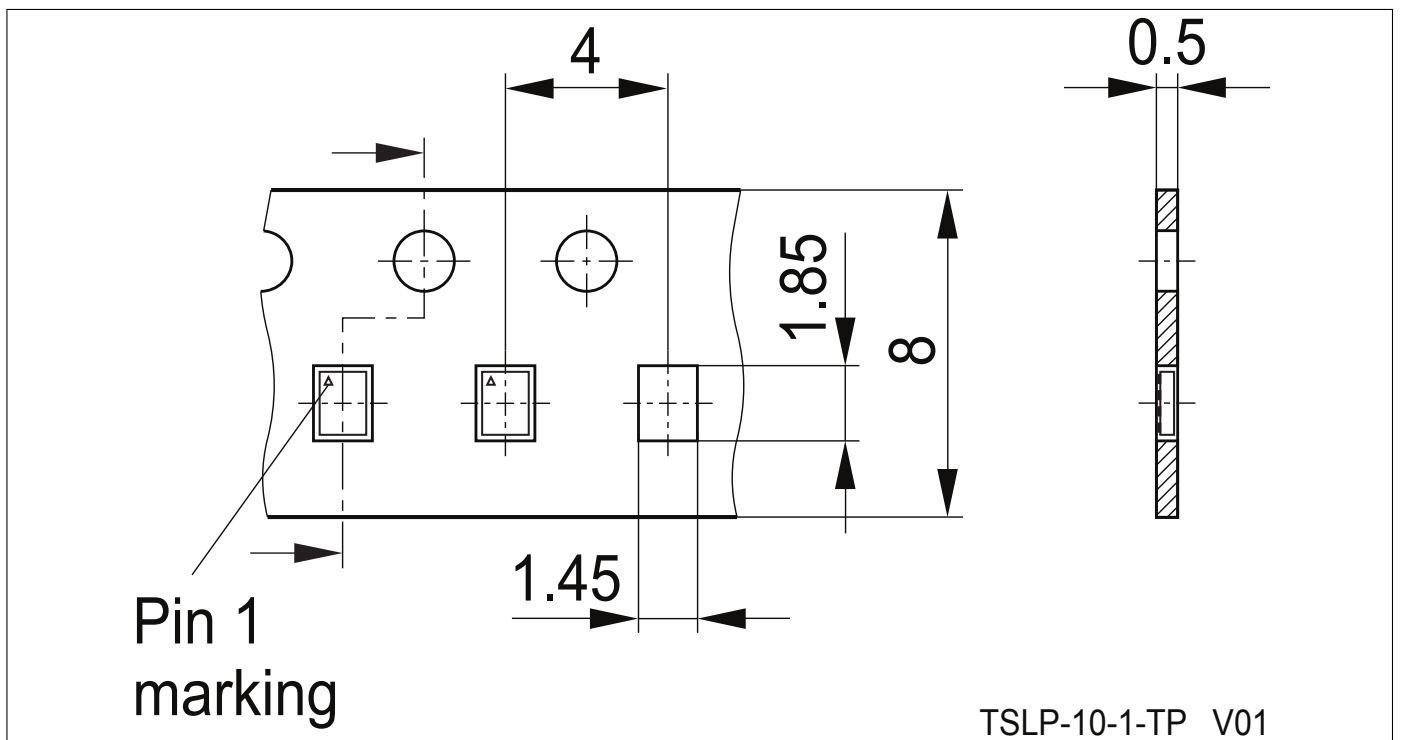

Figure 5: Tape and Reel Dimensions for TSLP-10-1

www.infineon.com

Published by Infineon Technologies AG