



Chipsmall Limited consists of a professional team with an average of over 10 year of expertise in the distribution of electronic components. Based in Hongkong, we have already established firm and mutual-benefit business relationships with customers from,Europe,America and south Asia,supplying obsolete and hard-to-find components to meet their specific needs.

With the principle of “Quality Parts,Customers Priority,Honest Operation,and Considerate Service”,our business mainly focus on the distribution of electronic components. Line cards we deal with include Microchip,ALPS,ROHM,Xilinx,Pulse,ON,Everlight and Freescale. Main products comprise IC,Modules,Potentiometer,IC Socket,Relay,Connector.Our parts cover such applications as commercial,industrial, and automotives areas.

We are looking forward to setting up business relationship with you and hope to provide you with the best service and solution. Let us make a better world for our industry!



Contact us

Tel: +86-755-8981 8866 Fax: +86-755-8427 6832

Email & Skype: info@chipsmall.com Web: www.chipsmall.com

Address: A1208, Overseas Decoration Building, #122 Zhenhua RD., Futian, Shenzhen, China



BGT24LTR11N16

Silicon Germanium 24GHz Radar
Transceiver MMIC

Data Sheet

Revision: 1.1

RF and Protection Devices

Edition 2016-09-28

**Published by
Infineon Technologies AG
81726 Munich, Germany**

**© 2016 Infineon Technologies AG
All Rights Reserved.**

Legal Disclaimer

The information given in this document shall in no event be regarded as a guarantee of conditions or characteristics. With respect to any examples or hints given herein, any typical values stated herein and/or any information regarding the application of the device, Infineon Technologies hereby disclaims any and all warranties and liabilities of any kind, including without limitation, warranties of non-infringement of intellectual property rights of any third party.

Information

For further information on technology, delivery terms and conditions and prices, please contact the nearest Infineon Technologies Office (www.infineon.com).

Warnings

Due to technical requirements, components may contain dangerous substances. For information on the types in question, please contact the nearest Infineon Technologies Office.

Infineon Technologies components may be used in life-support devices or systems only with the express written approval of Infineon Technologies, if a failure of such components can reasonably be expected to cause the failure of that life-support device or system or to affect the safety or effectiveness of that device or system. Life support devices or systems are intended to be implanted in the human body or to support and/or maintain and sustain and/or protect human life. If they fail, it is reasonable to assume that the health of the user or other persons may be endangered.

Data Sheet

Revision History: 2016-09-28

Previous Revision: Datasheet Rev. 1.0

Page	Subjects (major changes since last revision)
8	Minimum value for TX output power is changed to 2 dBm
9	Typical value for SSB noise figure is inserted

Trademarks of Infineon Technologies AG

AURIX™, C166™, CanPAK™, CIPOS™, CIPURSE™, EconoPACK™, CoolMOS™, CoolSET™, CORECONTROL™, CROSSAVE™, DAVE™, EasyPIM™, EconoBRIDGE™, EconoDUAL™, EconoPIM™, EiceDRIVER™, eupec™, FCOS™, HITFET™, HybridPACK™, I²RF™, ISOFACE™, IsoPACK™, MIPAQ™, ModSTACK™, my-d™, NovalithIC™, OptiMOS™, ORIGA™, PRIMARION™, PrimePACK™, PrimeSTACK™, PRO-SIL™, PROFET™, RASIC™, ReverSave™, SatRIC™, SIEGET™, SINDRION™, SIPMOS™, SmartLEWIS™, SOLID FLASH™, TEMPFET™, thinQ!™, TRENCHSTOP™, TriCore™.

Other Trademarks

Advance Design System™ (ADS) of Agilent Technologies, AMBA™, ARM™, MULTI-ICE™, KEIL™, PRIMECELL™, REALVIEW™, THUMB™, μVision™ of ARM Limited, UK. AUTOSAR™ is licensed by AUTOSAR development partnership. Bluetooth™ of Bluetooth SIG Inc. CAT-iq™ of DECT Forum. COLOSSUS™, FirstGPS™ of Trimble Navigation Ltd. EMV™ of EMVCo, LLC (Visa Holdings Inc.). EPCOS™ of Epcos AG. FLEXGO™ of Microsoft Corporation. FlexRay™ is licensed by FlexRay Consortium. HYPERTERMINAL™ of Hilgraeve Incorporated. IEC™ of Commission Electrotechnique Internationale. IrDA™ of Infrared Data Association Corporation. ISO™ of INTERNATIONAL ORGANIZATION FOR STANDARDIZATION. MATLAB™ of MathWorks, Inc. MAXIM™ of Maxim Integrated Products, Inc. MICROTEC™, NUCLEUS™ of Mentor Graphics Corporation. Mifare™ of NXP. MIPI™ of MIPI Alliance, Inc. MIPS™ of MIPS Technologies, Inc., USA. muRata™ of MURATA MANUFACTURING CO., MICROWAVE OFFICE™ (MWO) of Applied Wave Research Inc., OmniVision™ of OmniVision Technologies, Inc. Openwave™ Openwave Systems Inc. RED HAT™ Red Hat, Inc. RFMD™ RF Micro Devices, Inc. SIRIUS™ of Sirius Satellite Radio Inc. SOLARIS™ of Sun Microsystems, Inc. SPANSION™ of Spansion LLC Ltd. Symbian™ of Symbian Software Limited. TAIYO YUDEN™ of Taiyo Yuden Co. TEAKLITE™ of CEVA, Inc. TEKTRONIX™ of Tektronix Inc. TOKO™ of TOKO KABUSHIKI KAISHA TA. UNIX™ of X/Open Company Limited. VERILOG™, PALLADIUM™ of Cadence Design Systems, Inc. VLYNQ™ of Texas Instruments Incorporated. VXWORKS™, WIND RIVER™ of WIND RIVER SYSTEMS, INC. ZETEX™ of Diodes Zetex Limited.

Last Trademarks Update 2011-02-24

Table of Content

1	Introduction	5
1.1	Features	5
2	Electrical Characteristics	7
2.1	Absolute Maximum Ratings	7
2.2	ESD Integrity	7
2.3	Power Supply	7
2.4	TX Section	8
2.5	RX Section (Measured with TX_ON=0V)	9
2.6	Frequency Divider	9
2.7	Proportional to absolute temperature (PTAT) voltage source	9
3	Pin description	10
4	Physical Dimension	11

List of Figures

Figure 1	BGT24LTR11N16 in TSNP-16-9.....	5
Figure 2	BGT24LTR11N16 block diagram	6
Figure 3	Pin-out (top view)	10
Figure 4	Package Outline (top, side and bottom view) of TSNP-16-9	11
Figure 5	Marking Layout of TSNP-16-9 (example)	11
Figure 6	Soldering Footprint of TSNP-16-9.....	12
Figure 7	Packing Description of TSNP-16-9; ø Reel: 180 mm, Pieces / Reel: 3000, Reels / Box: 1	12

List of Tables

Table 1	Absolute maximum ratings: $T_A = -40\text{ °C} \dots 85\text{ °C}$; all voltages with respect to ground.....	7
Table 2	ESD integrity	7
Table 3	Power supply characteristics: $T_A = -40\text{ °C} \dots 85\text{ °C}$	7
Table 4	TX characteristics: $T_A = -40\text{ °C} \dots 85\text{ °C}$	8
Table 5	RX characteristics: $T_A = -40\text{ °C} \dots 85\text{ °C}$	9
Table 6	Frequency divider characteristics: $T_A = -40\text{ °C} \dots 85\text{ °C}$	9
Table 7	PTAT voltage source characteristics: $T_A = -40\text{ °C} \dots 85\text{ °C}$	9
Table 8	Pin definition and function	10

1 Introduction



1.1 Features

- 24GHz transceiver MMIC
- Fully integrated low phase noise VCO
- Built in temperature compensation circuit for VCO stabilization
- Homodyne quadrature receiver
- Frequency divider
- Low power consumption
- Fully ESD protected device
- Single ended RF and IF terminals
- 200 GHz bipolar SiGe:C technology b7hf200
- Single supply voltage 3.3V
- TSNP-16-9 plastic package
- Pb-free (RoHS compliant) package

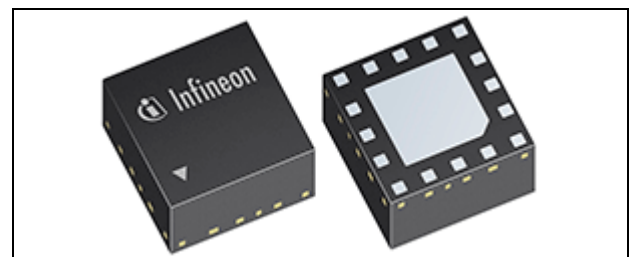

Figure 1 BGT24LTR11N16 in TSNP-16-9

Description

The BGT24LTR11 is a Silicon Germanium Transceiver MMIC operating from 24.0 GHz up to 24.25 GHz. It is based on a 24 GHz fundamental voltage controlled oscillator (VCO). A built in voltage source delivers a VCO tuning voltage (V_{PTAT}) which is proportional to absolute temperature. When connected to the VCO tuning pin (V_{TUNE}) it compensates for the inherent frequency drift of the VCO over temperature thus stabilizing the VCO within the ISM band eliminating the need for a PLL/Microcontroller. An integrated 1:16 frequency divider also allows for external phase lock loop VCO frequency stabilization.

The receiver section uses a low noise amplifier (LNA) in front of a quadrature homodyne down conversion mixer in order to provide excellent receiver sensitivity. Derived from the internal VCO signal, a RC polyphase filter (PPF) generates quadrature LO signals for the quadrature mixer. The I/Q IF outputs are available through a single ended terminal respectively.

The device is manufactured in a 0.18 μ m SiGe:C technology offering a cutoff frequency of 200 GHz. It is packaged in a 16 pin leadless RoHS compliant TSNP package.

Product Name	Package	Chip	Marking
BGT24LTR11N16	TSNP-16-9	T1811	LTR11

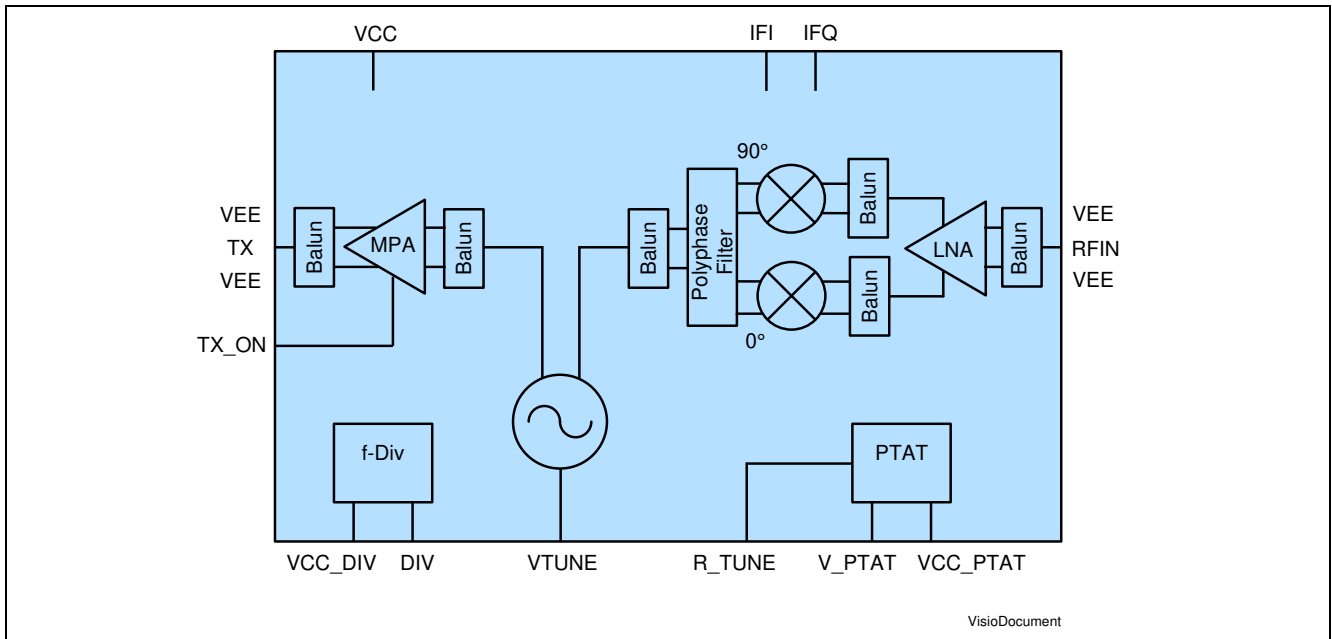

Figure 2 BGT24LTR11N16 block diagram

2 Electrical Characteristics

2.1 Absolute Maximum Ratings

Table 1 Absolute maximum ratings: $T_A = -40\text{ °C} \dots 85\text{ °C}$; all voltages with respect to ground

Parameter	Symbol	Value			Unit	Note/ Test Condition
		Min.	Typ.	Max.		
Supply voltage	V_{CC}	-0.3		3.6	V	
Supply voltage divider	V_{CC_DIV}	-0.3		3.6	V	
Supply voltage PTAT voltage source	V_{CC_PTAT}	-0.3		3.6	V	
DC voltage at RF pins	V_{DC_RF}			0		MMIC provides short circuit to GND for RF_IN and TX_OUT
Voltage applied to none-RF I/O pins	$V_{DC_I/O}$	-0.3		$V_{CC} + 0.3$	V	
Total power dissipation	P			300	mW	
Ambient temperature range	T_A	-40		85	°C	
Storage temperature range	T_{STG}	-50		125	°C	

2.2 ESD Integrity

Table 2 ESD integrity

Parameter	Symbol	Value			Unit	Note/ Test Condition
		Min.	Typ.	Max.		
ESD robustness HBM ¹	$V_{ESD-HBM}$	-1		1	kV	
ESD robustness CDM ²	$V_{ESD-CDM}$	-500		500	V	

1) According to ANSI/ESDA/JEDEC JS-001 (R = 1.5kOhm, C = 100pF) for Electrostatic Discharge Sensitivity Testing, Human Body Model (HBM)-Component Level

2) According to JEDEC JESD22-C101 Field-Induced Charged Device Model (CDM), Test Method for Electrostatic-Discharge-Withstand Thresholds of Microelectronic Components

Please note that this result is subject to:

- lot variations within the manufacturing process as specified by Infineon
- changes in the specific test setup

2.3 Power Supply

Table 3 Power supply characteristics: $T_A = -40\text{ °C} \dots 85\text{ °C}$

Parameter	Symbol	Value			Unit	Note/ Test Condition
		Min.	Typ.	Max.		
Supply voltage	V_{CC}	3.2	3.3	3.4	V	
Supply current	I_{CC}		45	55	mA	
Duty cycle		1 : 1000		1		
Pulse duration	t_P	1			µs	

2.4 TX Section
Table 4 TX characteristics: $T_A = -40\text{ °C} \dots 85\text{ °C}$

Parameter	Symbol	Value			Unit	Note/ Test Condition
		Min.	Typ.	Max.		
VCO frequency range	f_{VCO}	24.050		24.250	GHz	V_PTAT connected to VTUNE; 16 kOhm resistor connected from R_TUNE to GND
VCO phase noise	P_N			-55 -80	dBc/ Hz	@ 10 kHz offset @ 100 kHz offset
VCO AM noise	P_{AM}			-135	dBc/ Hz	@ 100 kHz offset
Tuning voltage to cover VCO frequency range	$VTUNE$	0.7		2.5	V	
VCO tuning sensitivity within VCO frequency range			720	2000	MHz/V	
Harmonic suppression		25			dBc	
Non-harmonic suppression		62			dBc	$f > 10\text{ GHz}$; $D_{DIV} = 16$
Non-harmonic suppression		45			dBc	$f \leq 10\text{ GHz}$; $D_{DIV} = 16$
TX output power	P_{TX}	2	6	10	dBm	
TX load impedance	Z_{TXOUT}		50		Ω	Single ended
TX_ON low level input voltage	$V_{TX_ON_low}$			0.8	V	
TX_ON high level input voltage	$V_{TX_ON_high}$	2			V	
TX_ON input voltage hysteresis	$V_{TX_ON_hys}$	50			mV	
TX_ON input current	I_{TX_ON}	-100		100	μA	
TX_ON switching time	t_{TX_ON}			2	ns	
Power up TX settling time	$t_{TX_Power_up}$			100ns		Defines the time TX section requires to settle after VCC supply voltage is within specified range

2.5 RX Section (Measured with TX_ON=0V)

Table 5 RX characteristics: $T_A = -40\text{ °C} \dots 85\text{ °C}$

Parameter	Symbol	Value			Unit	Note/ Test Condition
		Min.	Typ.	Max.		
RX frequency range	f_{RX}	24.0		24.25	GHz	
RX input impedance	Z_{RXIN}		50		Ω	Single ended
Voltage conversion gain	G_C	15.5	20	26.5	dB	
SSB noise figure	NF_{SSB}		10	18	dB	Single sideband @ $f_{IF} = 100\text{ kHz}$
Input compression point	IP_{1dB}	-28			dBm	
Quadrat. phase imbalance	ϵ_P	0		24	deg	
Quadrat. amplitude imbalance	ϵ_A	-1		1	dB	
IF output impedance	Z_{IF}			1	k Ω	Single ended

2.6 Frequency Divider

Table 6 Frequency divider characteristics: $T_A = -40\text{ °C} \dots 85\text{ °C}$

Parameter	Symbol	Value			Unit	Note/ Test Condition
		Min.	Typ.	Max.		
Prescaler division ratio	D_{DIV}	16		8192	-	16 if $V_{CC_PTAT} = 0\text{ V}$, 8192 if $V_{CC_PTAT} = 3.3\text{ V}$
Prescaler output voltage	V_{DIV}	60		500	mV	Peak to Peak voltage when DIV out is terminated with 50 Ohm and $D_{DIV}=16$
Prescaler supply voltage	V_{CC_DIV}	3.2	3.3	3.4	V	
Prescaler supply current	I_{CC_DIV}	13	19	25	mA	

2.7 Proportional to absolute temperature (PTAT) voltage source

Table 7 PTAT voltage source characteristics: $T_A = -40\text{ °C} \dots 85\text{ °C}$

Parameter	Symbol	Value			Unit	Note/ Test Condition
		Min.	Typ.	Max.		
Supply voltage	V_{CC_PTAT}	3.2	3.3	3.4	V	
Supply current	I_{CC_PTAT}		1.5	2.5	mA	
Output voltage	V_{OUT_PTAT}	0.7	1.3	2	V	

3 Pin description

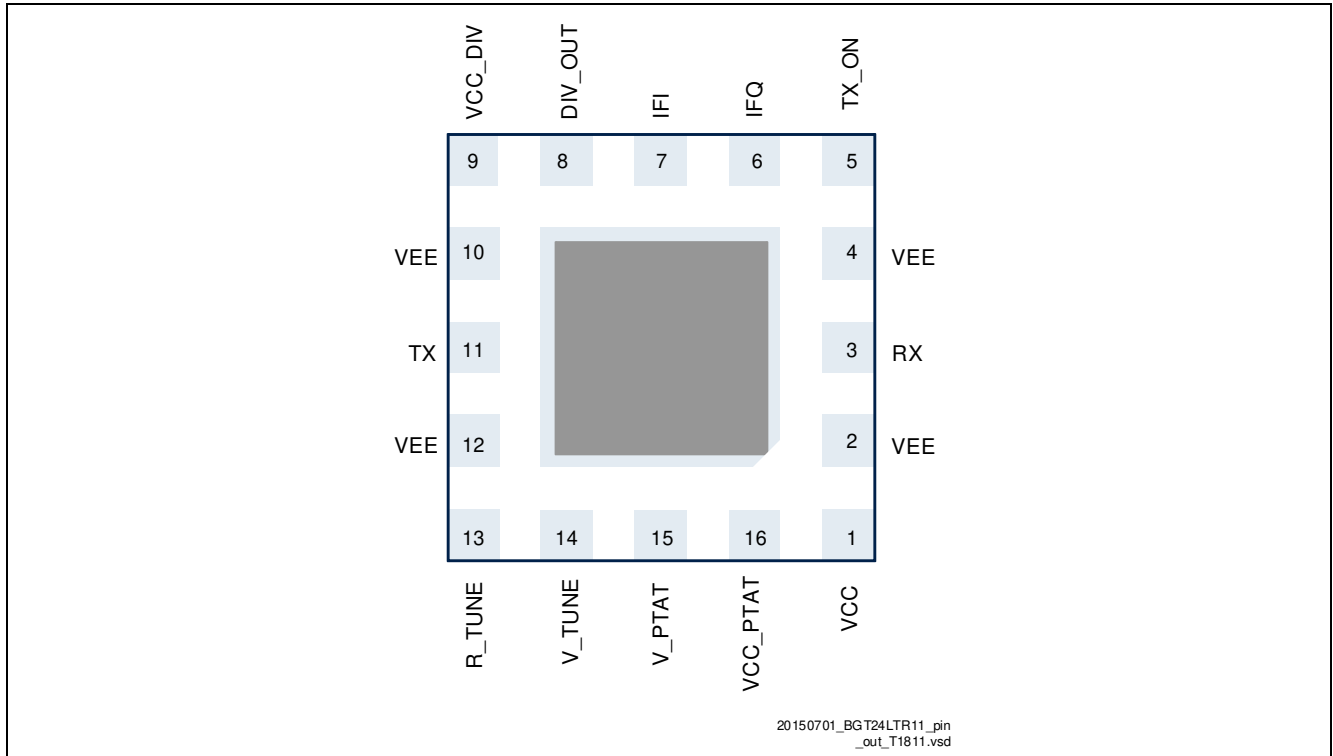

Figure 3 Pin-out (top view)

Table 8 Pin definition and function

Pin Number	Name	Function
1	VCC	Supply voltage
2	VEE	Ground
3	RX	Receiver RF input
4	VEE	GND
5	TX_EN	Output power enable
6	IFQ	Quadrature phase down converter IF output
7	IFI	In phase down converter IF output
8	DIV_OUT	Frequency divider output
9	VCC_DIV	Supply voltage of prescaler
10	VEE	Ground
11	TX	Transmitter RF output
12	VEE	Ground
13	R_TUNE	VCO operating frequency band select
14	V_TUNE	VCO frequency tuning input
15	V_PTAT	PTAT voltage source output
16	VCC_PTAT	PTAT voltage source power supply

4 Physical Dimension

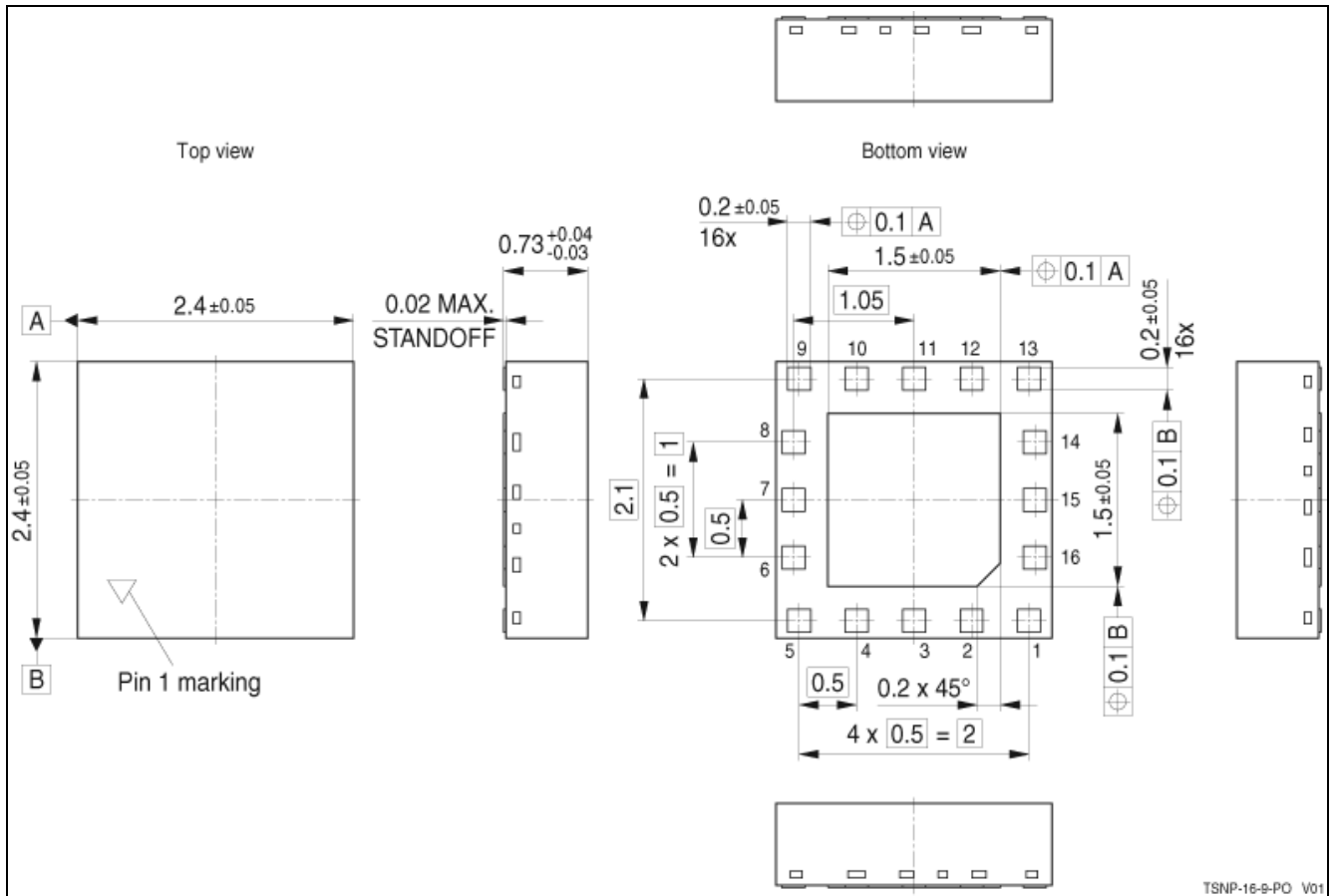

Figure 4 Package Outline (top, side and bottom view) of TSNP-16-9

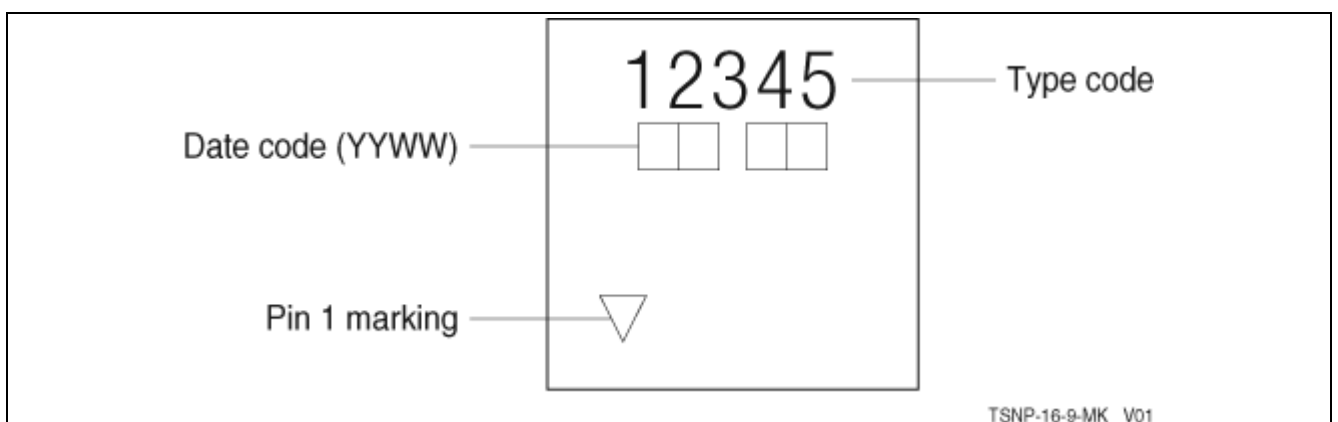

Figure 5 Marking Layout of TSNP-16-9 (example)

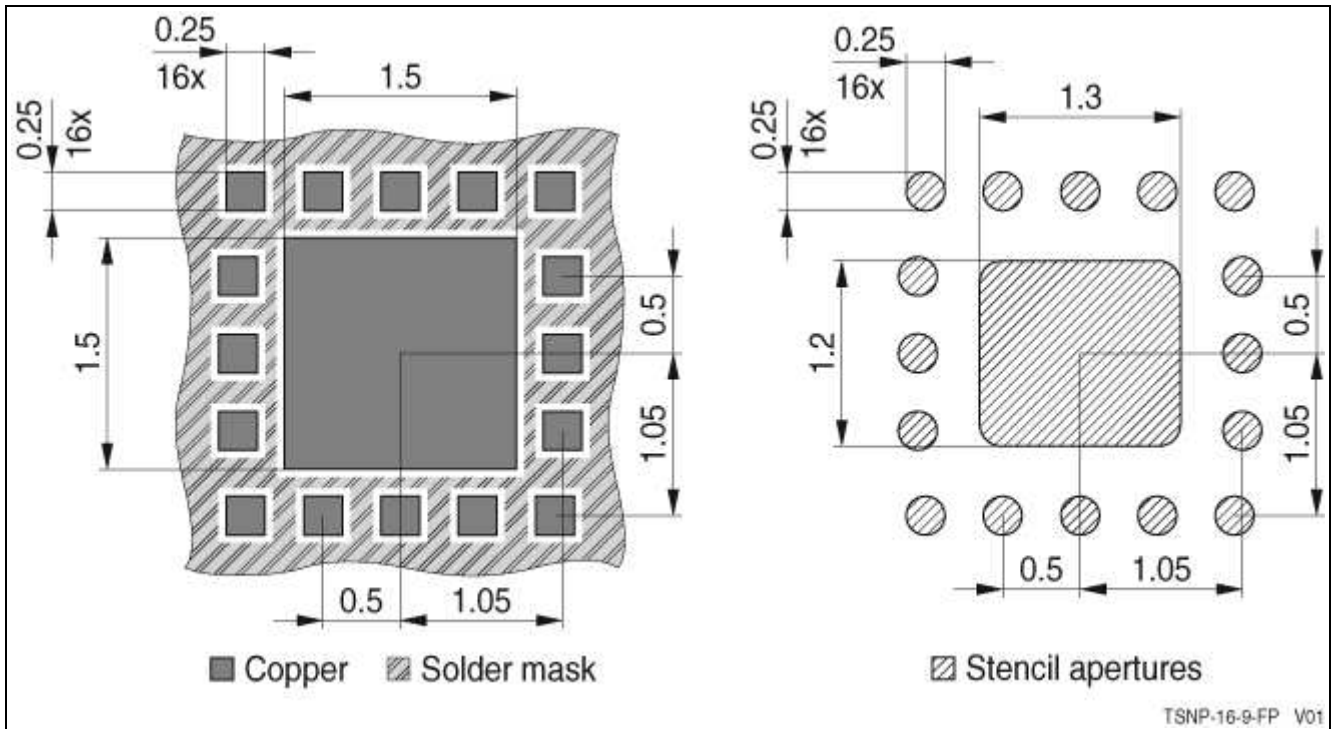

Figure 6 Soldering Footprint of TSNP-16-9

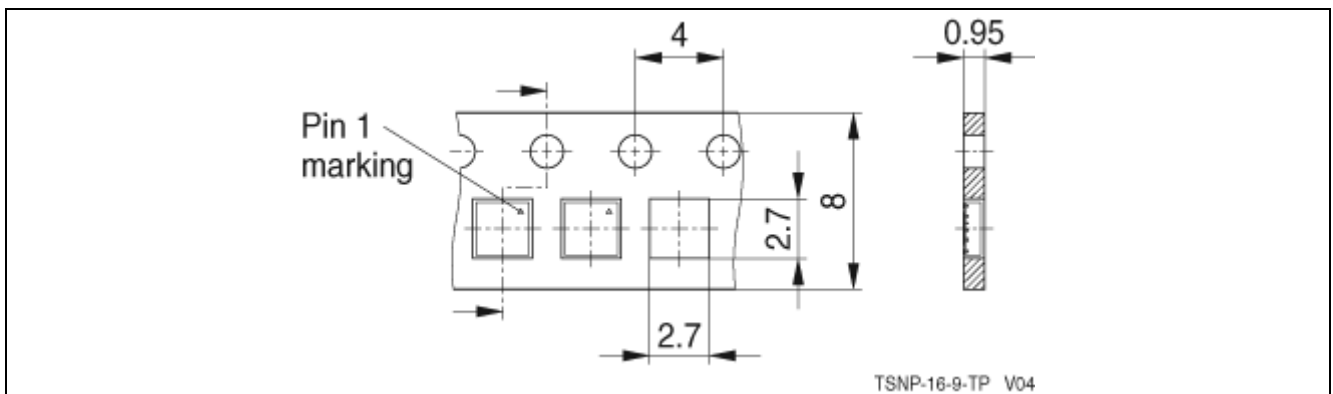

Figure 7 Packing Description of TSNP-16-9; Ø Reel: 180 mm, Pieces / Reel: 3000, Reels / Box: 1

www.infineon.com

Published by Infineon Technologies AG