



Chipsmall Limited consists of a professional team with an average of over 10 year of expertise in the distribution of electronic components. Based in Hongkong, we have already established firm and mutual-benefit business relationships with customers from,Europe,America and south Asia,supplying obsolete and hard-to-find components to meet their specific needs.

With the principle of “Quality Parts,Customers Priority,Honest Operation,and Considerate Service”,our business mainly focus on the distribution of electronic components. Line cards we deal with include Microchip,ALPS,ROHM,Xilinx,Pulse,ON,Everlight and Freescale. Main products comprise IC,Modules,Potentiometer,IC Socket,Relay,Connector.Our parts cover such applications as commercial,industrial, and automotives areas.

We are looking forward to setting up business relationship with you and hope to provide you with the best service and solution. Let us make a better world for our industry!



## Contact us

Tel: +86-755-8981 8866 Fax: +86-755-8427 6832

Email & Skype: info@chipsmall.com Web: www.chipsmall.com

Address: A1208, Overseas Decoration Building, #122 Zhenhua RD., Futian, Shenzhen, China



**BK-21669-000**  
SHT 1.1

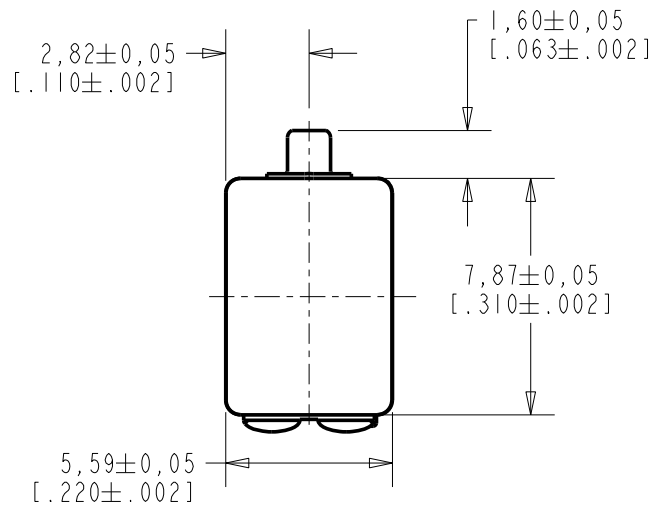

NOTES:

- 1 A POSITIVE GOING VOLTAGE AT TERMINAL 2, RELATIVE TO TERMINAL 1, CAUSES A DECREASE IN PRESSURE AT THE SOUND OUTLET.
- 2 LOCATED FROM TWO SURFACES FOR CUSTOMER CONVENIENCE. ONLY APPLICABLE FROM ONE SURFACE, NOT TO BE USED TOGETHER. HORIZONTAL LOCATION FOR TERMINAL CENTERED TO  $\pm 0,17$  [.007].

5,59±0,05  
[.220±.002]

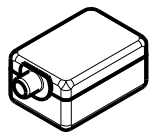
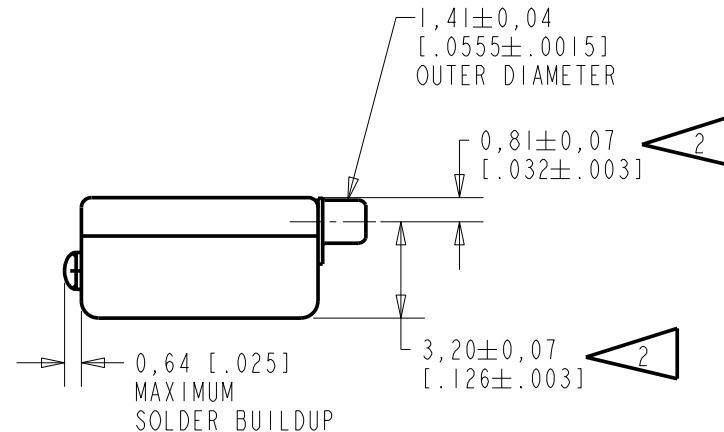
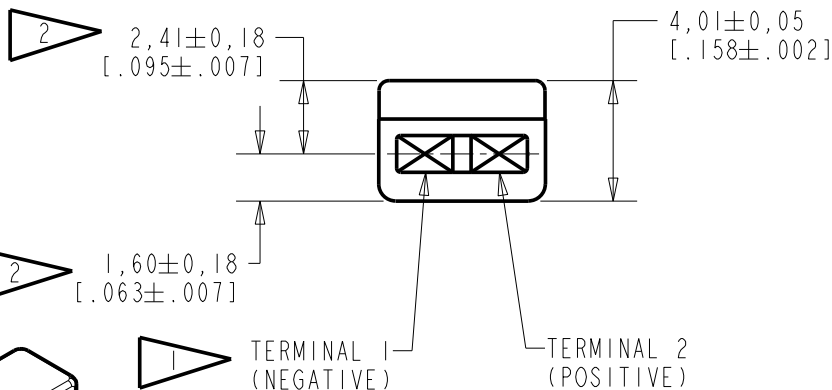

TERMINAL 1 (NEGATIVE)  
TERMINAL 2 (POSITIVE)

SCALE 2:1

NOMINAL WEIGHT  
.66 GRAM

DIMENSIONS IN MILLIMETERS [INCHES]

Revision	C.O. #	Implementation Date	RELEASE LEVEL	REVISION
C	C10108656	12-17-08	<b>Active</b>	<b>C</b>
B	C10106382	8-23-07		
A	C10103585	1-17-06		

SCALE: <b>4:1</b>		DR. BY	DATE
DO NOT SCALE DRAWING		CRG	1-17-06
TITLE: <b>RECEIVER</b>		CK. BY	DATE
<b>BK-21669-000</b>		GJP	1-19-06
OUTLINE DRAWING		APP. BY	DATE
<b>SHT 1.1</b>		GJP	1-19-06

**KNOWLES ELECTRONICS**  
ITASCA, ILLINOIS U.S.A.

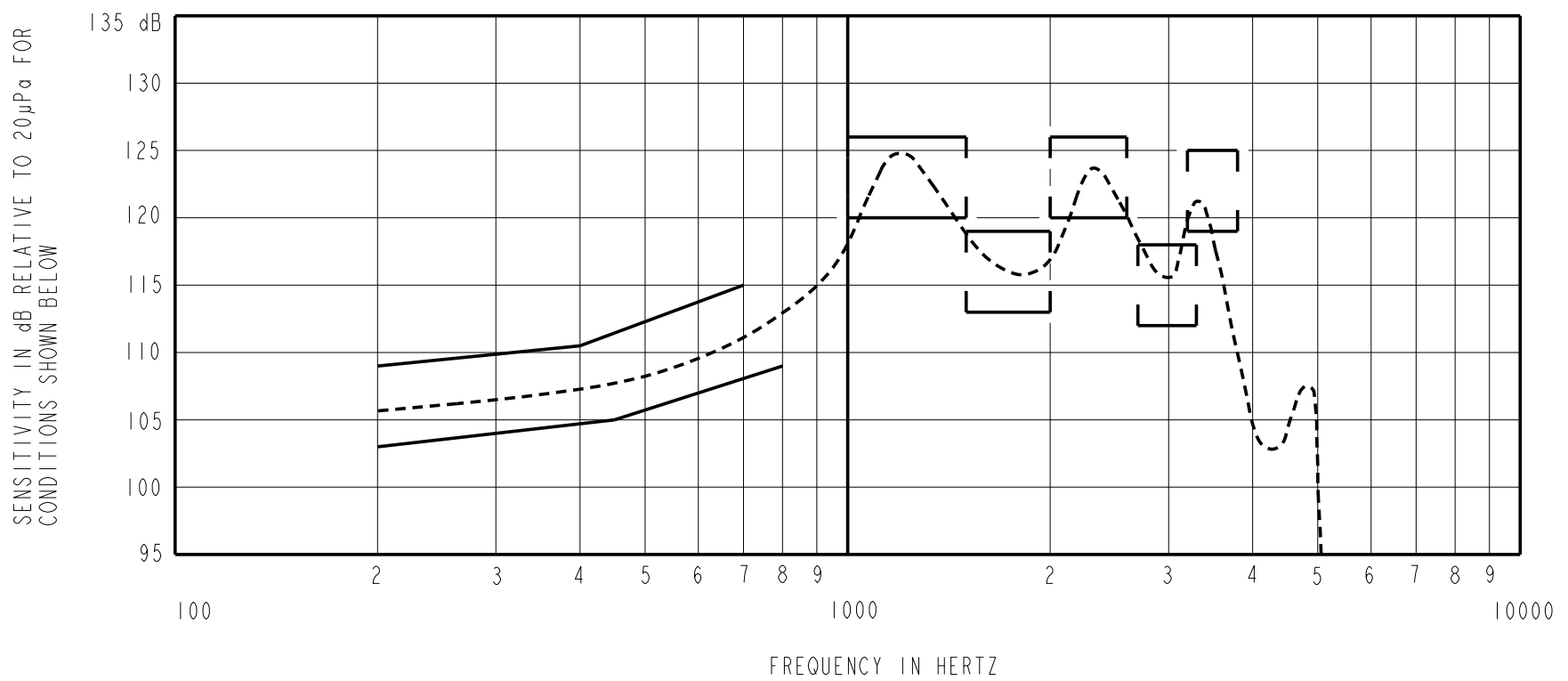

NOTES:

1. MEASUREMENTS MADE USING 27,9mm (.1100") X 1,4mm (.053") ID+10,2mm (.400")x 1,8mm (.070") ID + 23,1mm (.201") x 3,0mm (.118") ID TUBE CONNECTED TO 2CC COUPLER (TI278 AND B & K DB0138)

2. SENSITIVITY

FREQUENCY	MIN.	MAX.
200	103.0	109.0
400	---	110.5
450	105.0	---
700	---	115.0
800	109.0	---
1000-1500	120.0	127.0
1500-2000	113.0	119.0
2000-2600	120.0	126.0
2700-3300	112.0	118.0
3200-3800	119.0	125.0

- 3. RESPONSE, IMPEDANCE, AND DISTORTION MEASUREMENTS MADE USING THE ELECTRICAL TEST CONDITIONS SHOWN BELOW.
- 4. ELECTRICAL SOURCE IMPEDANCE MUST BE GREATER THAN 20 TIMES 1KHz IMPEDANCE FOR TEST CONDITIONS BELOW.
- 5. INDIVIDUAL SPECIFICATIONS.

PORT LOCATION	IMPEDANCE OHMS ±15%		DCR @20°C OHMS ±10%	DISTORTION		ELECTRICAL TEST CONDITIONS	
	1KHz	500Hz		MAX. %	FREQ Hz	AC mA RMS	DC mA
12C	59	22	9.0	10	500	3.61	0.00

Revision	C.O. #	Implementation Date	RELEASE LEVEL	REVISION
C	C10108656	12-17-08	Active	C
B	C10106382	8-23-07		
A	C10103585	1-17-06		

**KNOWLES ELECTRONICS**  
ITASCA, ILLINOIS U.S.A.

WHEN TEST LIMITS ARE USED TO ESTABLISH INCOMING INSPECTION ACCEPTANCE/REJECTION CRITERIA, CORRELATION OF TEST EQUIPMENT WITH KNOWLES IS ALSO REQUIRED FOR ELIMINATION OF EQUIPMENT AND TEST METHOD VARIATION

TITLE: **RECEIVER** **BK-21669-000**  
PERFORMANCE SPECIFICATION **SHT 2.1**

DR. BY	DATE
CRG	1-17-06
CK. BY	DATE
GJP	1-19-06
APP. BY	DATE
GJP	1-19-06