



Chipsmall Limited consists of a professional team with an average of over 10 year of expertise in the distribution of electronic components. Based in Hongkong, we have already established firm and mutual-benefit business relationships with customers from,Europe,America and south Asia,supplying obsolete and hard-to-find components to meet their specific needs.

With the principle of “Quality Parts,Customers Priority,Honest Operation,and Considerate Service”,our business mainly focus on the distribution of electronic components. Line cards we deal with include Microchip,ALPS,ROHM,Xilinx,Pulse,ON,Everlight and Freescale. Main products comprise IC,Modules,Potentiometer,IC Socket,Relay,Connector.Our parts cover such applications as commercial,industrial, and automotives areas.

We are looking forward to setting up business relationship with you and hope to provide you with the best service and solution. Let us make a better world for our industry!



Contact us

Tel: +86-755-8981 8866 Fax: +86-755-8427 6832

Email & Skype: info@chipsmall.com Web: www.chipsmall.com

Address: A1208, Overseas Decoration Building, #122 Zhenhua RD., Futian, Shenzhen, China



Ferrite Bead Inductor BL01RN1A□□□□
Reference Specification

1.Scope

This reference specification applies Ferrite Bead Inductor.

2.Part Numbering

(Ex.)	<u>BL</u>	<u>01</u>	<u>RN</u>	<u>1</u>	<u>A1</u>	<u>F</u>	<u>1</u>	<u>A</u>
	Product ID	Series	Bead Core Material	Number of Bead Core	(*1)Lead Type	(*2)Lead Length, Space	(*3)Lead Diameter	(*4)Packaging
	(*1) A1 : Axial Straight Type		(*2) D : Lead Length 45.0mm min.		(*3) 1 : ϕ 0.60mm		(*4) A : Ammo Pack	
	A2 : Axial Crimp Type		A : Lead Length 3.7mm		2 : ϕ 0.65mm		B : Bulk	
			F : Lead Length 52.0mm					
			E : Lead Length 26.0mm					

3. Rating

Customer Part Number	MURATA Part Number	Rated Current	Inductance (1MHz)	DC Resistance	Unit Mass (Typical value)
	BL01RN1A1D2B	7 A	0.45 μ H min.	0.02 Ω max.	0.35g
	BL01RN1A2A2B				0.29g
	BL01RN1A1F1A	6 A			0.38g
	BL01RN1A1E1A				0.32g

· Operating Temperature : - 40 °C to + 85 °C

· Storage Temperature : - 40 °C to + 100 °C

4. Style and Dimension

Bulk : See item 9 or 10

■ Equivalent Circuits

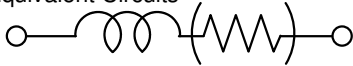

(Resistance element becomes dominant at high frequencies.)

5. Marking

No Marking

6. Testing Conditions

<Unless otherwise specified>

Temperature : Ordinary Temp. 15°C to 35°C

Humidity : Ordinary Humidity 25 %(RH) to 85 %(RH)

<In case of doubt>

Temperature : 20°C \pm 2°C

Humidity : 60 %(RH) to 70 %(RH)

Atmospheric pressure : 86kPa to 106kPa

7. Electrical Performance

No.	Item	Specification	Test Method
7.1	Bead Bonding Strength	Appearance : No damage.	Applying Force : 9.8N Applying direction : The lead wire in the direction of the axes. Keeping Time : 1s to 5s
7.2	Drop	Appearance : No damage.	Products shall be dropped on the plate of oak. Height : 75 cm The Number of Times : 3 times
7.3	Solderability	Along the circumference of terminal shall be covered with new solder at least 75%	Flux : Ethanol solution of rosin, 25(wt)% Pre-heat : 150 \pm 10 °C, 60 ~ 90 s Solder : Sn-3.0Ag-0.5Cu Solder Temperature : 245 \pm 5 °C Immersion Time : 2 \pm 0.5 s

No.	Item	Specification	Test Method
7.4	Resistance to Soldering Heat	Appearance : No damage.	Flux : Ethanol solution of rosin, 25(wt)% Pre-heat : 150 ± 10 °C, 60 ~ 90 s Solder : Sn-3.0Ag-0.5Cu Solder Temperature : 260 ± 5 °C Immersion Time : 10 ± 1 s Immersion Depth : 1.6 ± 0.8 mm from the end of Ferrite Bead Immersion and emersion rates : 25 ± 5 mm / s
7.5	Resistance to Soldering iron		Tip Temperature : 350 °C ± 10 °C Soldering Time : 3 s ± 0.5 s Putting place of soldering iron : lead wire (1.6 ± 0.8 mm from the bottom of the Ferrite Bead) Do not touch the Ferrite Bead directly with the tip of the soldering iron.
7.6	Vibration		Oscillation Frequency : 10 Hz to 2000 Hz for 20 min. Total Amplitude or acceleration : 1.5 mm or 196 m/s ² Testing Time : A period of 2 hours in each of 3 mutually perpendicular directions. (Total 6 hours)
7.7	Humidity	Appearance : No damaged. Inductance change : within $\pm 15\%$	Temperature : 85 °C ± 2 °C Humidity : 80 %(RH) to 85 %(RH) Time : 500 h (+ 24h , - 0h) Then measured after exposure in the room condition for 1 to 2 hours.
7.8	Thermal Shock		1 cycle : 1 step : -40 °C (+0,-3) °C / 30 min. (+3,-0) min. 2 step : Ordinary Temp. / within 1 min. 3 step : $+85$ °C (+3,-0) °C / 30min. (+3,-0) min. 4 step : Ordinary Temp. / within 1min. Total of 10 cycles Then measured after exposure in the room condition for 4 to 48 hours.
7.9	Heat Resistance		Temperature : 85 °C ± 3 °C Time : 1000 h (+ 48h , - 0h) Then measured after exposure in the room condition for 1 to 2 hours.

8. Frequency-Impedance Characteristics (Typical)

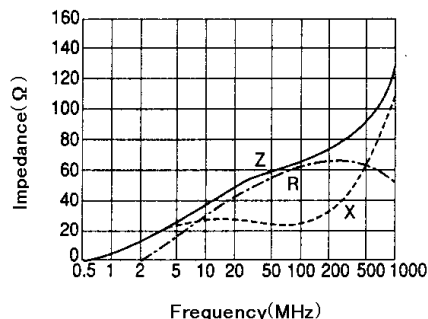

9. Style and Dimension (Bulk)

(1) BL01RN1A1D2B

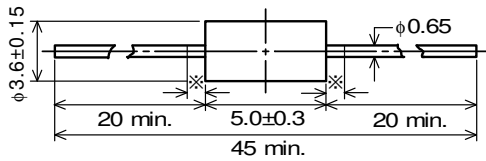

(2) BL01RN1A2A2B

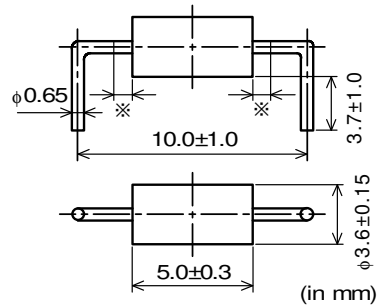

※ Coating extending on leads : 1.5 max.

10. Specification of Packaging

10.1. Style and Dimension

BL01RN1A1F1A / BL01RN1A1E1A

Murata Part Number	L
BL01RN1A1F1A	52 (+2, - 1)
BL01RN1A1E1A	26 (+1.5, - 0)

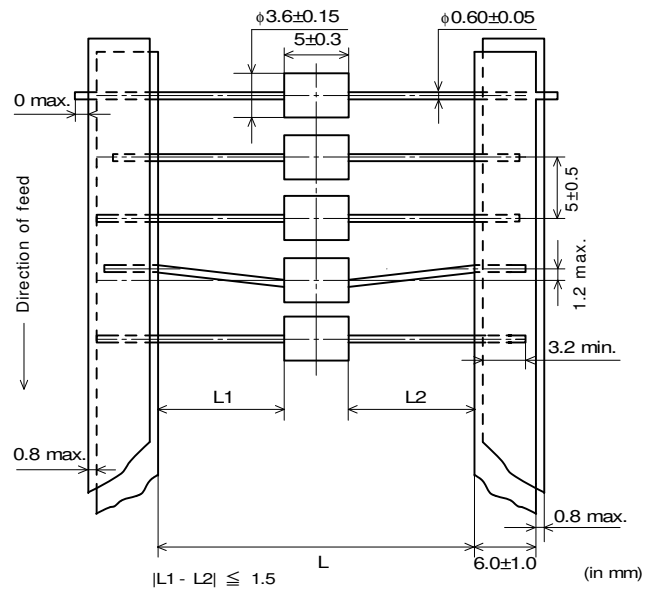

10.2. Supplement condition of taping

- (1) Carrier tape shall be spliced as the following figures. Overall thickness shall be less than 4 times of taping thickness.

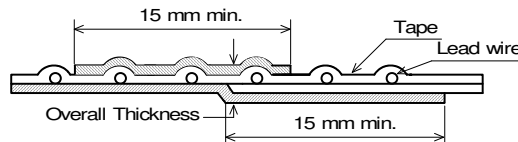

- (2) A maximum of 0.25% of the inductor per packing quantity may be missing without consecutive missing inductors.

10.3. Leader of tape

Not less than 3 consecutive of component shall be missing on both edge of tape.

11. Packing

11.1. Packing quantity

The standard packing quantity is as follows.

Murata Part Number	Quantity (pcs.)	Remark
BL01RN1A1D2B	500	Bulk
BL01RN1A2A2B		
BL01RN1A1F1A	1500	Ammo Pack
BL01RN1A1E1A	1000	

12. ⚠ Caution**Limitation of Applications**

Please contact us before using our products for the applications listed below which require especially high reliability for the prevention of defects which might directly cause damage to the third party's life, body or property.

- | | |
|--|--|
| (1) Aircraft equipment | (7) Traffic signal equipment |
| (2) Aerospace equipment | (8) Disaster prevention / crime prevention equipment |
| (3) Undersea equipment | (9) Data-processing equipment |
| (4) Power plant control equipment | (10) Applications of similar complexity and /or reliability requirements to the applications listed in the above |
| (5) Medical equipment | |
| (6) Transportation equipment (vehicles, trains, ships, etc.) | |

13. Notice**13.1. Soldering**

(1) Flux, Solder

- Rosin-based flux should be used.
- Do not use strong acidic flux with halide content exceeding 0.2(wt)% (chlorine conversion value.)
- Use Sn-3.0Ag-0.5Cu solder.

(2) Standard flow soldering profile.

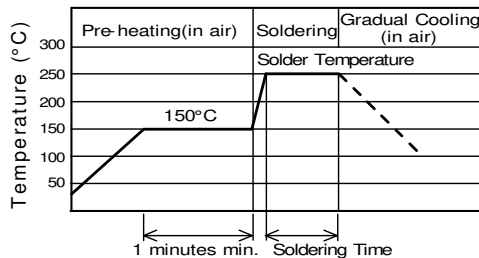

Solder Temperature	Soldering Time
250 ~ 260 °C	4 ~ 6 s

- (3) Resistance to soldering iron goes in the following condition that tip temperature is 350 °C max, and soldering time is 5 s max.
- (4) Products and the leads should not be subjected to any mechanical stress during soldering process. (and also while subjected to the equivalent high temperature.)

13.2. Cleaning conditions

Products shall be cleaned on the following conditions.

- (1) Cleaning temperature shall be limited to 60°C max.(40°C max for IPA.)
- (2) Ultrasonic cleaning shall comply with the following conditions with avoiding the resonance phenomenon at the mounted products and P.C.B.
Power : 20 W / l max. Frequency : 28kHz to 40kHz Time : 5 min max.
- (3) Cleaner
1. Alcohol type cleaner
 - Isopropyl alcohol (IPA)
 2. Aqueous agent
 - PINE ALPHA ST-100S
- (4) There shall be no residual flux and residual cleaner after cleaning. In case of using aqueous agent, products shall be dried completely after rinse with de-ionized water in order to remove the cleaner.
- (5) Other cleaning
Please contact us.

13.3. Operating Environment

- (1) Do not use products in corrosive gases such as chlorine gas, acid or sulfide gas.
- (2) Do not use products in the environment where water, oil or organic solvents may adhere to product.
- (3) Do not adhere any resin to products, coat nor mold products with any resin (including adhesive) to prevent mechanical and chemical stress on products.

13.4. Storage and Handling Requirements

(1) Storage period

- Use the products within 12 months after delivered.
- Solderability should be checked if this period is exceeded.

(2) Storage conditions

- Products should be stored in the warehouse on the following conditions.

Temperature : -10 °C to 40 °C

Humidity : 15 % to 85 % relative humidity No rapid change on temperature and humidity

The electrode of the products is coated with solder. Don't keep products in corrosive gases such as sulfur, chlorine gas or acid, or it may cause oxidization of electrode, resulting in poor solderability.

- Products should not be stored on bulk packaging condition to prevent the chipping of the core and the breaking of winding wire caused by the collision between the products.
- Products should be stored on the palette for the prevention of the influence from humidity, dust and so on.
- Products should be stored in the warehouse without heat shock, vibration, direct sunlight and so on.

(3) Handling Condition

Care should be taken when transporting or handling product to avoid excessive vibration or mechanical shock.

14.  Note

- (1) Please make sure that your product has been evaluated in view of your specifications with our product being mounted to your product.
- (2) You are requested not to use our product deviating from the reference specifications.
- (3) The contents of this reference specification are subject to change without advance notice. Please approve our product specifications or transact the approval sheet for product specifications before ordering.