



Chipsmall Limited consists of a professional team with an average of over 10 year of expertise in the distribution of electronic components. Based in Hongkong, we have already established firm and mutual-benefit business relationships with customers from,Europe,America and south Asia,supplying obsolete and hard-to-find components to meet their specific needs.

With the principle of “Quality Parts,Customers Priority,Honest Operation,and Considerate Service”,our business mainly focus on the distribution of electronic components. Line cards we deal with include Microchip,ALPS,ROHM,Xilinx,Pulse,ON,Everlight and Freescale. Main products comprise IC,Modules,Potentiometer,IC Socket,Relay,Connector.Our parts cover such applications as commercial,industrial, and automotives areas.

We are looking forward to setting up business relationship with you and hope to provide you with the best service and solution. Let us make a better world for our industry!



Contact us

Tel: +86-755-8981 8866 Fax: +86-755-8427 6832

Email & Skype: info@chipsmall.com Web: www.chipsmall.com

Address: A1208, Overseas Decoration Building, #122 Zhenhua RD., Futian, Shenzhen, China



Date	SYM	REVISION RECORD	AUTH	DR.	CK.
6/20/08	A	UPDATED NOTE FOR CONTACT MATERIAL	T.B.	B.S.	
12/19/08	B	UPDATED SPECIFICATIONS	T.B.	B.S.	
03/26/10	C	UPDATED PCB LAYOUT	T.B.	B.S.	
07/06/12	D	DIM. 9.94 WAS 8.56	T.B.	B.S.	

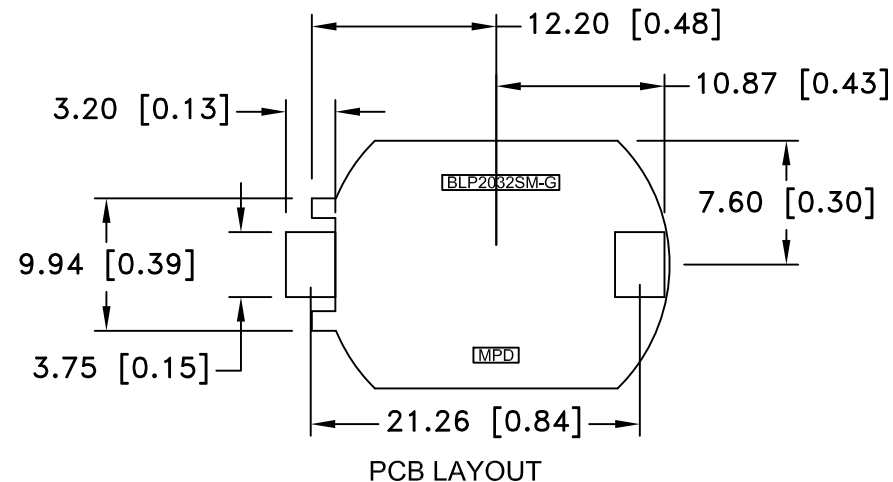
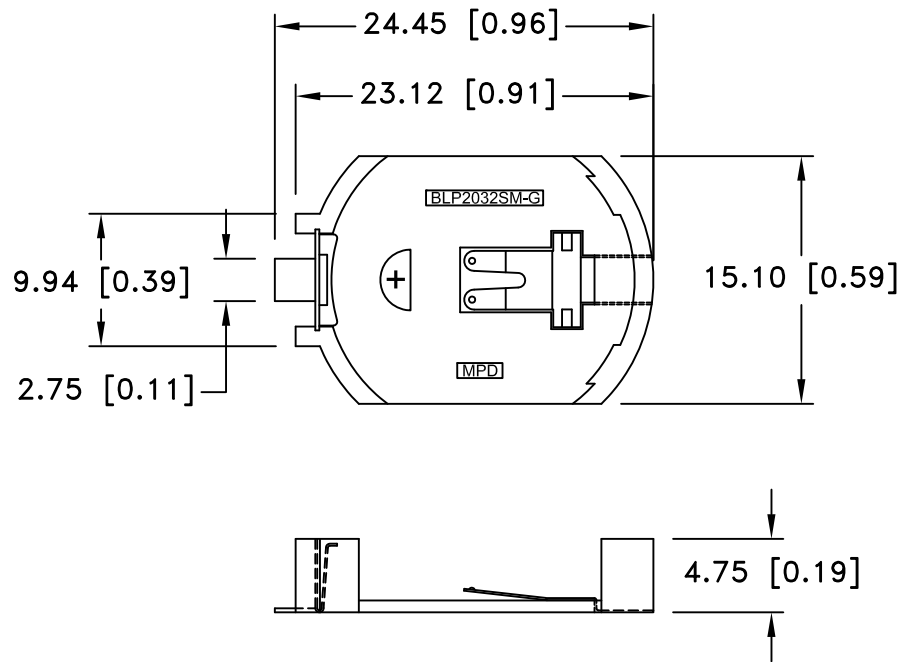

SPECIFICATIONS:

- * Holder material- 30% glass reinforced Liquid Crystal Polymer resin, UL File No. E123598, UL94V-0
- * Color: White
- * Contacts : 0.020" thick Stainless steel 301, 3/4 hard , GOLD FLASH over nickel
- * Temperature range: -40°C to +280°C

Vibration Test: 10-50-10 Hz swept in 60 seconds

X,Y,Z direction: 1 hour each direction, No dislodgement of the cell or damage, No discontinuity over 10 micro-seconds

Shock Test: Half sine wave acceleration 150g. 6 micro-seconds, 3 shock pulses each direction per axis, total of 18 pulses, No evidence of physical damage

ROHS COMPLIANT

Tolerance (Except as noted)	 Memory Protection Devices, Inc 200 Broad Hollow Road, Farmingdale, New York 11735	Scale	Drawn By B.S.
			Approved By T.B.
decimal ±.5 (.020)	Title SURFACE MOUNT BATTERY HOLDER FOR CR2032		
Fractional ± .8 (.030)		Date 07/06/12	Drawing Number BLP2032SM-GTR
Angular ± 3°			