



Chipsmall Limited consists of a professional team with an average of over 10 year of expertise in the distribution of electronic components. Based in Hongkong, we have already established firm and mutual-benefit business relationships with customers from,Europe,America and south Asia,supplying obsolete and hard-to-find components to meet their specific needs.

With the principle of “Quality Parts,Customers Priority,Honest Operation,and Considerate Service”,our business mainly focus on the distribution of electronic components. Line cards we deal with include Microchip,ALPS,ROHM,Xilinx,Pulse,ON,Everlight and Freescale. Main products comprise IC,Modules,Potentiometer,IC Socket,Relay,Connector.Our parts cover such applications as commercial,industrial, and automotives areas.

We are looking forward to setting up business relationship with you and hope to provide you with the best service and solution. Let us make a better world for our industry!



Contact us

Tel: +86-755-8981 8866 Fax: +86-755-8427 6832

Email & Skype: info@chipsmall.com Web: www.chipsmall.com

Address: A1208, Overseas Decoration Building, #122 Zhenhua RD., Futian, Shenzhen, China



BMA180

Digital, triaxial acceleration sensor

Bosch Sensortec



BOSCH

Invented for life

General description

The BMA180 is an ultra high performance digital triaxial acceleration sensor, aiming for low power consumer market applications.

The BMA180 allows high accurate measurement of accelerations in 3 perpendicular axes and thus senses tilt, motion, shock and vibration in cell phones, handhelds, computer peripherals, man-machine interfaces, virtual reality features and game controllers.

BMA180 target applications

- ▶ Navigation (INS/Dead Reckoning)
- ▶ High accurate tilt detection (e.g. tilt compensated compass)
- ▶ Pointing and menu scrolling
- ▶ Display profile switching (portrait/landscape)
- ▶ Gaming
- ▶ Drop detection for warranty logging
- ▶ Shock detection
- ▶ Step-counting

Sensor operation

The BMA180 represents a new generation of digital acceleration sensors with a unique performance and feature set within 3 mm x 3 mm x 0.9 mm standard LGA package.

Key features BMA180

- ▶ All parameters and features user programmable
- ▶ 7 user programmable g-ranges and 10 selectable bandwidth settings
- ▶ Low-power consumption
- ▶ Ultra-low-power self-wake-up mode
- ▶ User programmable interrupt engine
- ▶ 0g offset regulation and in-field offset re-calibration with ultra-high accuracy
- ▶ SPI (4-wire)/I²C interface
- ▶ RoHS compliant, halogen-free

The BMA180 is highly configurable in order to give the designer full flexibility when integrating the sensor into his system. All features can be set by software via the digital interface. Here the user can choose between an I²C and an SPI (4-wire) interface mode.

Technical data	BMA180
Sensitivity axes	x/y/z
Measurement range (switchable via SPI/I ² C)	±1g, ±1.5g, ±2g, ±3g, ±4g, ±8g, ±16g
Sensitivity (calibrated)	1g: 8192LSB/g 1.5g: 5460LSB/g 2g: 4096LSB/g 3g: 2730LSB/g 4g: 2048LSB/g 8g: 1024LSB/g 16g: 512LSB/g
Resolution	14bit ⇒ 0.244mg (±2g range) (switchable 12 bit option)
Nonlinearity	±0.15% FS (±2g range)
Zero-g offset (ex-factory)	±15mg
Zero-g offset (after offset fine tuning)	±5mg
Zero-g offset temperature drift	±0.5mg/K
Noise density	150µg/√Hz
Bandwidth (switchable via SPI/I ² C)	low pass 10Hz ... 1200Hz high pass 1Hz band pass 0.2 ... 300Hz
Digital input/output	SPI & I ² C, interrupt pin
Supply voltages	V _{DD} 1.62 ... 3.6V V _{DDIO} 1.20 ... 3.6V
Current consumption	650µA
Temperature range	-40°C ... +85°C

One of the key elements of the BMA180 is the intelligent interrupt engine that gives the hard- and software designer full control. Various motion detection scenarios can be identified by the BMA180 and signaled to the system via a simple interrupt pin. By using the digital serial interface, the exact details of the motion event that triggered the interrupt can be read-out.

Following motion detection use case scenarios are supported by the interrupt engine:

- ▶ Any-motion (slope) detection
- ▶ Tap sensing
- ▶ Low-g/high-g detection
- ▶ Data-ready with sample skipping option
- ▶ Self-wake-up

The interrupts can be conveniently configured by the user and thus perfectly support the integration of the BMA180 into the user's system environment.

Another important feature of the BMA180 acceleration sensor is the power management module. This module allows for optimizing the sensor's power consumption in-line with the specific user requirements. Thus, it is not necessary to operate the sensor at full power for all application scenarios all the time. For some use cases the power consumption drastically shrinks to just a fraction of what would be required in full performance mode. Moreover this feature of the BMA180 allows for an intelligent system power management and thus significant reduction of the whole system's power consumption. In particular, this helps increasing battery life-time of any kind of mobile device.

BMA180 Pin configuration (top view)

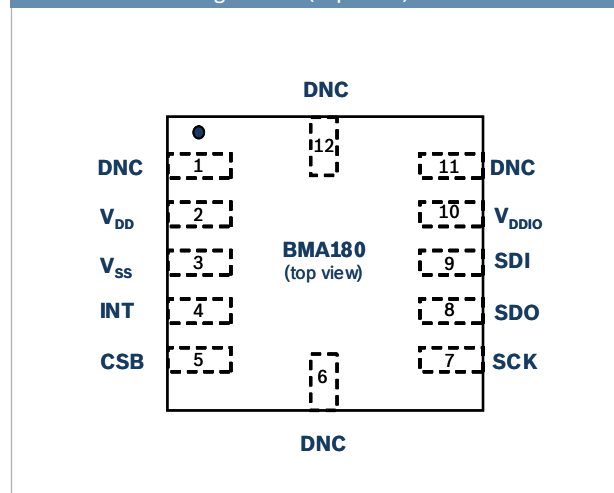

Pin No.	Name	Function
1	DNC	Do not connect
2	VDD	Analog supply voltage
3	VSS	Ground
4	INT	Interrupt output
5	CSB	SPI chip select
6	DNC	Do not connect
7	SCK	Serial clock
8	SDO	Serial data output
9	SDI	Serial data in/out
10	VDDIO	Digital interface power supply
11	DNC	Do not connect
12	DNC	Do not connect

Headquarters

Bosch Sensortec GmbH

Gerhard-Kindler-Strasse 8
 72770 Reutlingen · Germany
 Telephone +49 7121 3535 900
 Fax +49 7121 3535 909
contact@bosch-sensortec.com
www.bosch-sensortec.com