



Chipsmall Limited consists of a professional team with an average of over 10 year of expertise in the distribution of electronic components. Based in Hongkong, we have already established firm and mutual-benefit business relationships with customers from,Europe,America and south Asia,supplying obsolete and hard-to-find components to meet their specific needs.

With the principle of “Quality Parts,Customers Priority,Honest Operation,and Considerate Service”,our business mainly focus on the distribution of electronic components. Line cards we deal with include Microchip,ALPS,ROHM,Xilinx,Pulse,ON,Everlight and Freescale. Main products comprise IC,Modules,Potentiometer,IC Socket,Relay,Connector.Our parts cover such applications as commercial,industrial, and automotives areas.

We are looking forward to setting up business relationship with you and hope to provide you with the best service and solution. Let us make a better world for our industry!



Contact us

Tel: +86-755-8981 8866 Fax: +86-755-8427 6832

Email & Skype: info@chipsmall.com Web: www.chipsmall.com

Address: A1208, Overseas Decoration Building, #122 Zhenhua RD., Futian, Shenzhen, China



BMD-100 Nucleo Shield User Guide

This guide provides setup instructions for starting development and describes the hardware functionality of the **BMD-100 Nucleo Shield** from Rigado.

The BMD-100 Nucleo Shield is an easy and convenient start development when adding Bluetooth Low Energy connectivity to a system. The BMD-100 is based on the ST Microelectronics BlueNRG-MS chipset, providing the 2.4GHz transceiver, BLE software stack and GATT/ATT-based access to an external host MCU through a SPI slave port.



1. Overview

The BMD-100 Nucleo Shield provides an easy starting point for almost any Bluetooth 4.1 Low Energy project. The shield conforms to the Arduino UNO R3 pin layout (up to 3.6V only), allowing use with different host MCUs and development platforms. Using an ST Microelectronics STM32 Nucleo Development kit is one of the easiest ways to get up and running with the BMD-100 and is described in this guide.

In addition to the BMD-100, the shield also includes a SPI EEPROM for the optional local storage of configuration parameters, as well as a current sense resistor for conducting power measurements.

1.1. Key Features

- Compact Bluetooth 4.1 Low Energy solution with integrated chip antenna
- Works with STM32 Nucleo boards and the ARM mbed IoT and other popular development tools.
- Based on the BlueNRG-MS network processor from ST Microelectronics
- Embedded Bluetooth low energy protocol stack: GAP, GATT, SM, L2CAP, LL, RF-PHY
- Excellent RF link budget (up to 96 dB)
- Up to +8 dBm available output power
- Accurate RSSI to allow power control
- Down to 1.7 μ A current consumption with active BLE stack

Table of Contents

| | |
|--------------------------------------------|-----------|
| 1. Overview | 1 |
| 1.1. Key Features..... | 1 |
| 2. Getting Started | 3 |
| 2.1. Hardware Requirements..... | 3 |
| 2.2. Development Environments | 3 |
| 2.3. Setting up the Board | 3 |
| 3. Hardware Description | 4 |
| 3.1. BMD-100 Nucleo Shield | 5 |
| 3.2. SPI and GPIO Connection Options | 6 |
| 4. Component Description..... | 7 |
| 4.1. BMD-100 Module..... | 7 |
| 4.2. SPI EEPROM..... | 8 |
| 4.3. Current Measurement | 8 |
| 5. Schematic | 9 |
| 6. Document History | 10 |
| 7. Related Documents | 10 |

Table of Figures

| | |
|------------------------------------------------------------------------|---|
| Figure 1: BMD-100 Nucleo Shield installed on a STM32 Nucleo board..... | 3 |
| Figure 2: BMD-100 Nucleo Shield Pinout | 4 |
| Figure 3: BMD-100 Nucleo Shield Assembly Drawing | 4 |
| Figure 4: BMD-100..... | 7 |
| Figure 5: EEPROM | 8 |
| Figure 6: Current Measurement | 8 |
| Figure 7: BMD-100 Nucleo Shield Schematic | 9 |

Table of Tables

| | |
|------------------------------------------------------------------------------------|---|
| Table 1: STM32 Nucleo board and BMD-100 Nucleo Shield connection, left-side | 5 |
| Table 2: STM32 Nucleo board and BMD-100 Nucleo Shield connection, right-side | 6 |
| Table 3: BlueNRG-MS interface (optional) with the STM32 Nucleo board | 6 |
| Table 4: BMD-100 Details | 7 |
| Table 5: SPI EEPROM Details..... | 8 |

2. Getting Started

This section walks through how to set up and program the BMD-100 Nucleo Shield.

2.1. Hardware Requirements

The BMD-100 Nucleo Shield is an expansion board for use with STM32 Nucleo boards as well as other Arduino-style MCU boards. When used with a STM32 Nucleo board, the BMD-100 Nucleo Shield is simply connected to the STM32 Nucleo board as shown in Figure 1.

The STM32 Nucleo firmware and related documentation is available at <http://www.st.com/stm32nucleo>

The interconnection between the STM32 Nucleo and the BMD-100 Nucleo Shield has been designed to permit the use of any STM32 Nucleo board. The NUCLEO-L053R8 and the NUCLEO-F401RE development boards offer the best compatibility with the available tools and sample code.



Figure 1: BMD-100 Nucleo Shield installed on a STM32 Nucleo board

2.2. Development Environments

ST Microelectronics supplies various tools that can be used with BMD-100 Nucleo Shield connected to STM32 Nucleo boards. A typical development system consists of:

- ⚙ Windows PC (XP or newer) to install the firmware package
- ⚙ USB type A to Mini-B USB cable to connect the Nucleo board to the PC
- ⚙ Installation of the [ST STM32CubeMX](#) code generator and the [ST X-CUBE-BLE1](#) BLE expansion pack
- ⚙ Installation of the [ST STSW-BLUENRG-DK](#) BlueNRG graphical user interface utility. Sample code is also provided with the BlueNRG-DK.

The mbed.org development environment may be used. The [ST BlueNRG-MS library](#) can be used directly with the BMD-100 Nucleo Shield connected to a STM32 Nucleo board.

Using other Arduino-style platforms with the BMD-100 Nucleo Shield will require the development environment and libraries for the chosen platform.

2.3. Setting up the Board

To set up the board, perform the following steps:

1. Connect the BMD-100 Nucleo Shield to the STM32 Nucleo board as shown in Figure 1
2. Power the Nucleo board using the Mini-B USB cable
3. Program the firmware in the STM32 on the Nucleo board using the firmware example provided
4. Reset the MCU board using the reset button available on the Nucleo board
5. The evaluation kit is ready to be used

3. Hardware Description

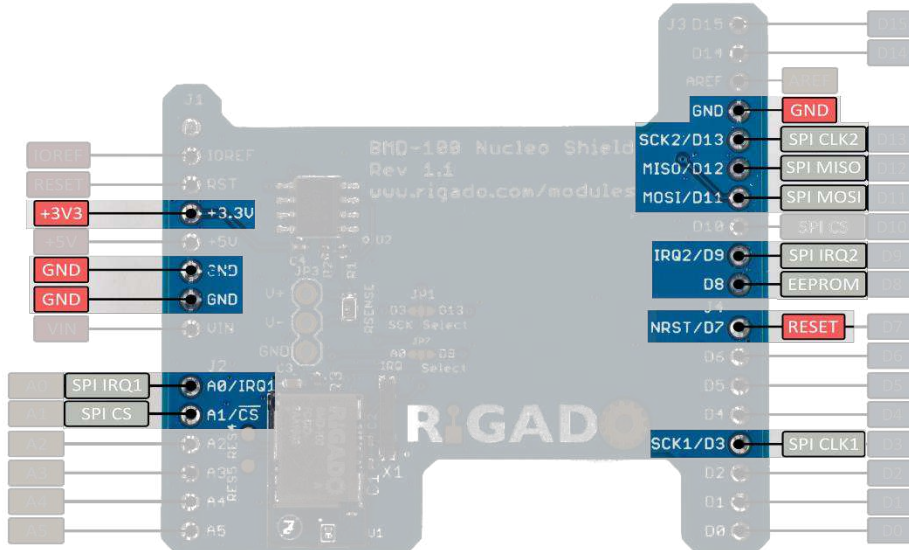

Figure 2: BMD-100 Nucleo Shield Pinout

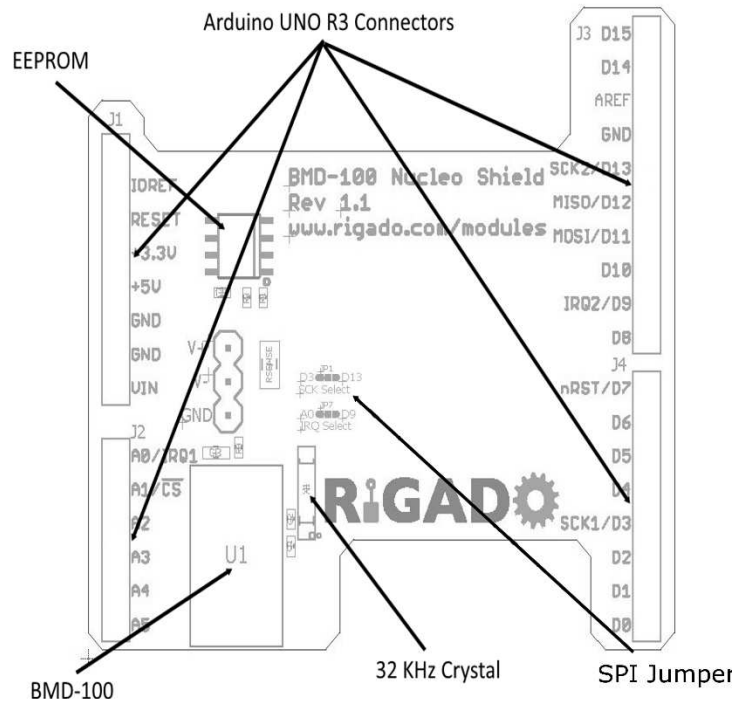

Figure 3: BMD-100 Nucleo Shield Assembly Drawing

3.1. BMD-100 Nucleo Shield

The shield allows the user to test the functionality of the BMD-100 module and to integrate it into their application without requiring custom hardware. The BMD-100 hosts the BlueNRG-MS, a very low power Bluetooth Low Energy (BLE) single-mode network processor, compliant with Bluetooth specification v4.1. The module also embeds the innovative BALF-NRG-01D3 (balun with integrated harmonic filter) and a chip antenna.

Its functionality can be exploited using the firmware package contained in the X-CUBE-BLE1. This is the easiest approach to programming the microcontroller on the STM32 Nucleo board. Please refer to user manuals UM1724 and UM1725, available on www.st.com. Sample code is also available through the BlueNRG DK.

The BMD-100 module and the STM32 Nucleo board are connected through connectors CN5, CN6, CN8 and CN9 in Table 1 and Table 2, below. The pins marked with an asterisk (*) allow that specific pin function to be moved to the standard Arduino SPI pin assignments: SPI_CLK on CN5.6 (signal name D13) and SPI_CSN on CN5.3 (signal name D10).

| Arduino Signal Name | | Connector Name | Pin # | NUCLEO-L053R8 (MCU Port) | BMD-100 Nucleo Shield |
|---------------------|----------------|----------------|-------|--------------------------|-----------------------|
| NC | Left Connector | CN6 Power | 1 | | |
| IOREF | | | 2 | | |
| RESET | | | 3 | | |
| 3V3 | | | 4 | | 3V3 |
| 5V | | | 5 | | |
| GND | | | 6 | | GND |
| GND | | | 7 | | GND |
| VIN | | | 8 | | |
| A0 | | CN8 Analog | 1 | PA0 | SPI_IRQ |
| A1 | | | 2 | PA1 | SPI_CSN (*) |
| A2 | | | 3 | PA4 | |
| A3 | | | 4 | PB0 | |
| A4 | | | 5 | PC1/PB9 | |
| A5 | | | 6 | PC0/PB8 | |

Table 1: STM32 Nucleo board and BMD-100 Nucleo Shield connection, left-side

| Arduino Signal Name | Connect or Name | Pin # | NUCLEO-053R8 (MCU Port) | BMD-100 Nucleo Shield | |
|---------------------|-----------------|-------------|-------------------------|-----------------------|----------------|
| D15 | Right Connector | CN5 Digital | 10 | PB8 | |
| D14 | | | 9 | PB9 | |
| AREF | | | 8 | | |
| GND | | | 7 | | GND |
| D13 | | | 6 | PA5 | SPI_CLK (Opt) |
| D12 | | | 5 | PA6 | SPI_MISO |
| D11 | | | 4 | PA7 | SPI_MOSI |
| D10 | | | 3 | PB6 | SPI_CSN (Opt) |
| D9 | | | 2 | PC7 | SPI_IRQ |
| D8 | | | 1 | PA9 | SPI_EEPROM_Ns |
| D7 | | CN9 Digital | 8 | PA8 | BMD-100_nRESET |
| D6 | | | 7 | PB10 | |
| D5 | | | 6 | PB4 | |
| D4 | | | 5 | PB5 | |
| D3 | | | 4 | PB3 | SPI_CLK (*) |
| D2 | | | 3 | PA10 | |
| D1 | 2 | | PA2 | | |
| D0 | 1 | PA3 | | | |

Table 2: STM32 Nucleo board and BMD-100 Nucleo Shield connection, right-side

3.2. SPI and GPIO Connection Options

Table 3 below shows the SPI and GPIO connection options between the STM32 and BlueNRG-MS hosted on the BMD-100 module. These allow use with other Arduino-style MCU boards as well as operation of the board in configurations in cases where different expansion boards are utilized or there is a conflict of signals.

| BMD-100 Pin | Default STM32 Port | Optional STM32 Port |
|---------------------|--------------------|-----------------------------------------------------------------------------------------------------------------|
| 18 – SPI_IRQ | PA0 (Arduino A0) | PC7 (Arduino D9) Cut the trace between pins 1 and 2 on JP7. Solder a jumper between pins 2 and 3 on JP7. |
| 17 – SPI_CLK | PB3 (Arduino D3) | PA5 (Arduino D13) Cut the trace between pins 1 and 2 on JP1. Solder a jumper between pins 2 and 3 on JP1. |

Table 3: BlueNRG-MS interface (optional) with the STM32 Nucleo board

Refer to the schematic diagram on page 9 for additional details. For the optional connections, modify the firmware for the correct use of the STM32 resources to be used.

4. Component Description

The board has the following devices.

4.1. BMD-100 Module

The BMD-100 is an easy-to-use Bluetooth Low Energy module. It is based on the BlueNRG-MS device, which is a very low power Bluetooth Low Energy single-mode network processor, compliant with Bluetooth specification v4.1. The BMD-100 has the following certifications:

- ⚙️ FCC (FCC ID: 2AA9B02)
- ⚙️ IC (IC: 12208A-02)
- ⚙️ CE (EN 301 489-1 V1.9.2, EN 301 489-17 V2.2.1, EN 300 328 V1.8.1)

The interface of the device to the STM32 Nucleo boards is through the SPI interface and GPIOs. The BMD-100 integrates a 32 MHz crystal oscillator for the BlueNRG-MS, a ST BALF-NRG-01D3 balun and chip antenna. The 32.768 kHz crystal oscillator is optional for the BlueNRG-MS on the BMD-100 and is included in the shield circuit. The part numbers used to develop this application are shown in Table 4 below.

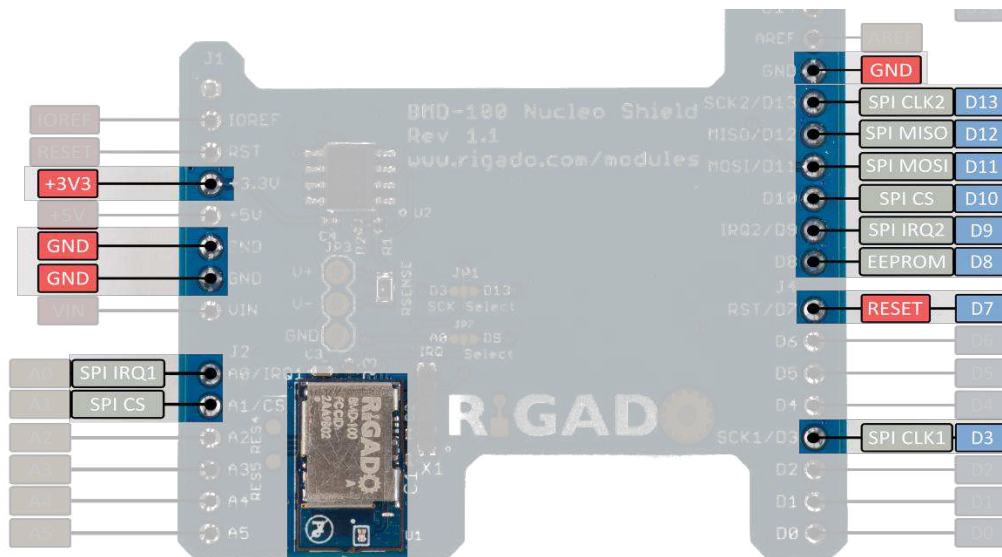

Figure 4: BMD-100

| Feature | Description |
|-------------------|--------------|
| Part Number | BMD-100 |
| Package | LGA 26 pin |
| Operating Voltage | 1.7V to 3.6V |

Table 4: BMD-100 Details

4.2. SPI EEPROM

The M95640-R is a 64 Kbit serial SPI bus EEPROM with high-speed clock interface. The device can be used to store the configuration parameters related to applications or settings of the BMD-100 module.

The part numbers used to develop this application are shown in Table 5 below.

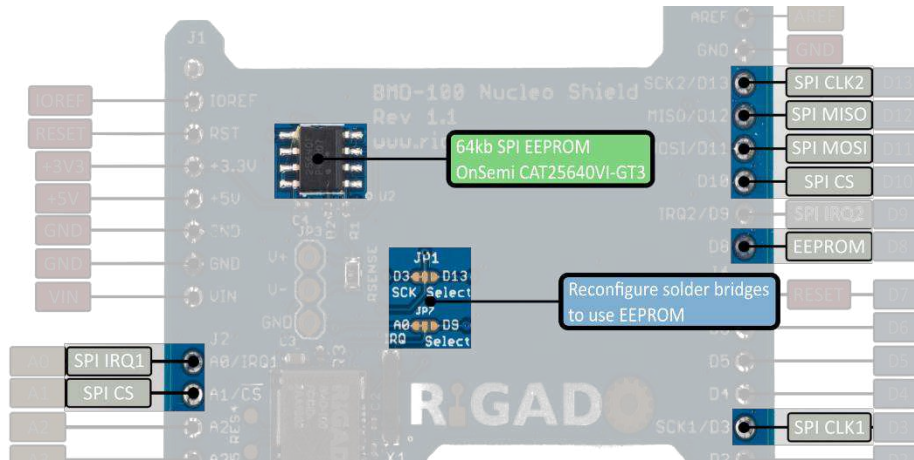

Figure 5: EEPROM

| Feature | Description |
|-------------------|----------------|
| Part Number | CAT25640VI-GT3 |
| Package | 8SOIC |
| Operating Voltage | 1.8V to 5.5V |

Table 5: SPI EEPROM Details

4.3. Current Measurement

To monitor the power consumption of the BMD-100, a 1.0Ω series resistor is provided on the module's power input. Connect a voltmeter across pin 1 (V+) and pin 2 (V-) of J1. Since the power consumption of BMD-100 is very low during most of its operating time, an accurate instrument in the range of a few μV may be required.

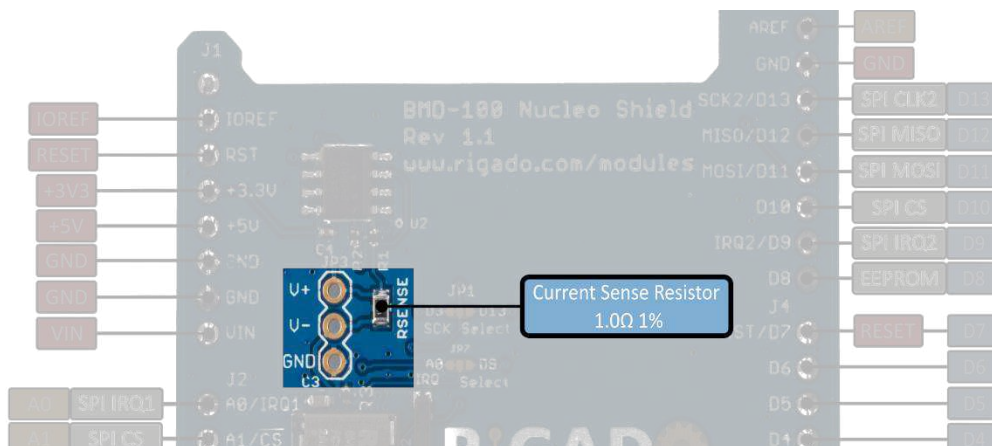

Figure 6: Current Measurement

5. Schematic

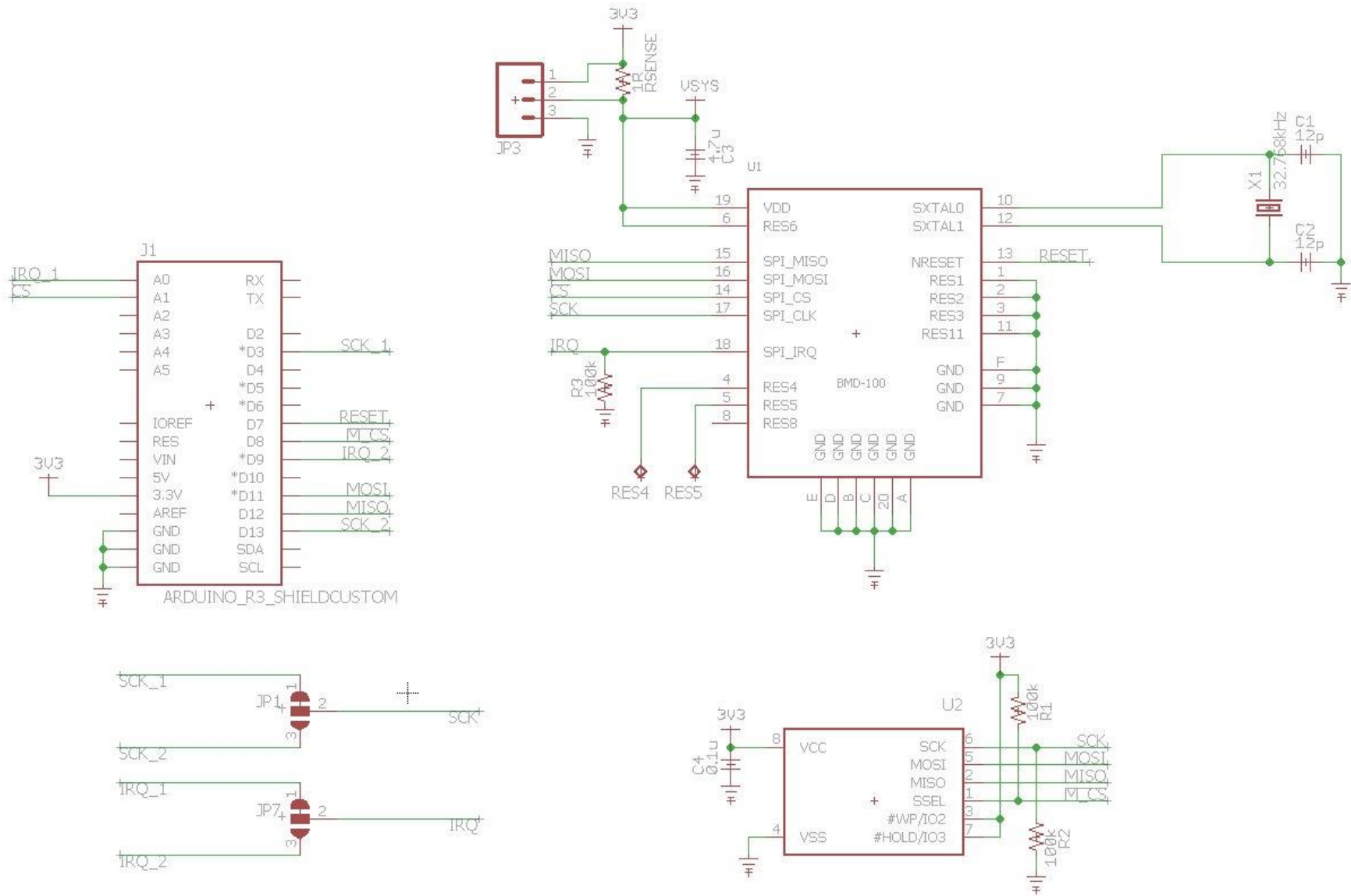

Figure 7: BMD-100 Nucleo Shield Schematic

6. Document History

| Revision | Date | Changes / Notes |
|----------|------------|-----------------|
| 1.0 | 04/13/2016 | Initial release |
| | | |
| | | |

7. Related Documents

Rigado Documents:

- ⚙ [BMD-100-DS: Module Datasheet](#)
- ⚙ [BMD-100-PB: Module Product Brief](#)

ST Documents

- ⚙ [STSW-BLUENRG-DK: BlueNRG Graphical User Interface](#)
- ⚙ [BlueNRG-MS: Single-mode Network Processor Datasheet](#)