



Chipsmall Limited consists of a professional team with an average of over 10 year of expertise in the distribution of electronic components. Based in Hongkong, we have already established firm and mutual-benefit business relationships with customers from,Europe,America and south Asia,supplying obsolete and hard-to-find components to meet their specific needs.

With the principle of “Quality Parts,Customers Priority,Honest Operation,and Considerate Service”,our business mainly focus on the distribution of electronic components. Line cards we deal with include Microchip,ALPS,ROHM,Xilinx,Pulse,ON,Everlight and Freescale. Main products comprise IC,Modules,Potentiometer,IC Socket,Relay,Connector.Our parts cover such applications as commercial,industrial, and automotives areas.

We are looking forward to setting up business relationship with you and hope to provide you with the best service and solution. Let us make a better world for our industry!



## Contact us

Tel: +86-755-8981 8866 Fax: +86-755-8427 6832

Email & Skype: info@chipsmall.com Web: www.chipsmall.com

Address: A1208, Overseas Decoration Building, #122 Zhenhua RD., Futian, Shenzhen, China



# BMD040

## Analog pressure sensor

### Data sheet

Bosch Sensortec



**BOSCH**  
Invented for life



#### **BMD040 Data sheet**

Order code	0 273 300 139
Package type	TO-8
Data sheet version	1.3
Release date	23 October 2008
Document number	BST-BMD040-DS000-03
Notes	Specification subject to change without notice. Proprietary information, not intended for publication. Product photos and pictures are for illustration purposes only and may differ from the real product's appearance.

 <b>BOSCH</b>	<b>Data sheet</b> <b>BMD040</b>	Bosch Sensortec
--	------------------------------------	-----------------

## BMD040 - High precision 3MPa absolute pressure sensor

### Key features

- High precision barometric pressure sensor
- Pressure range: 50 ... 3,000kPa
- TO-8 metal can package
- Fully calibrated
- Temperature compensated
- Fast ratiometric analog output technology
- ESD-protection and short circuit protected
- Inverse polarity protected up to 300mA supply current and on board diagnosis capability due to high driver output
- Temperature range -30 ... +100°C
- RoHS-compliant

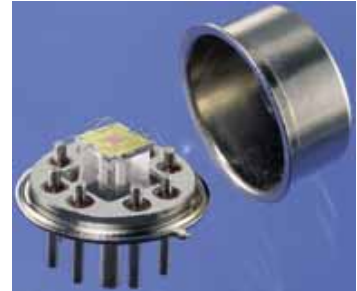

### Typical applications

- HVAC (heating, ventilation, air-conditioning)
- Fuel pressure measurement
- Air pressure measurement
- Hydraulic pressure measurement

### General description

The BMD040 analog output, absolute pressure sensor comprises a piezo-resistive pressure sensor element and a circuitry for signal amplification and temperature compensation. Both components are integrated on a single silicon chip. The active surface of the silicon chip is exposed to a reference vacuum that is formed by an evacuated TO-type housing. The medium to be measured is led up by a pressure nozzle to the back side of the diaphragm, which is resistant to most of the measured media.

## Table of contents

<b>1</b>	<b>DATA</b> .....	<b>4</b>
1.1	MAXIMUM RATINGS OF PRESSURE SENSOR.....	4
1.2	OPERATING CHARACTERISTICS OF PRESSURE SENSOR.....	4
1.3	SIGNAL EVALUATION.....	5
1.4	SIGNAL RANGE CHECK.....	5
1.5	TRANSFER FUNCTION OF PRESSURE SENSOR.....	6
1.6	ACCURACY OF PRESSURE SENSOR.....	7
1.7	DATA OF CLK PIN.....	8
1.8	TYPICAL TEMPERATURE DEPENDENCE OF CLK-PIN (SCHEMATIC).....	8
<b>2</b>	<b>INSTALLATION INSTRUCTIONS</b> .....	<b>9</b>
<b>3</b>	<b>ASSEMBLY INSTALLATION</b> .....	<b>10</b>
<b>4</b>	<b>MAXIMUM STORAGE TIME</b> .....	<b>11</b>
<b>5</b>	<b>PIN ASSIGNMENT</b> .....	<b>12</b>
<b>6</b>	<b>PACKAGE</b> .....	<b>13</b>
<b>7</b>	<b>LEGAL DISCLAIMER</b> .....	<b>14</b>
7.1	PRODUCT USE.....	14
7.2	ENGINEERING SAMPLES.....	14
7.3	APPLICATION EXAMPLES AND HINTS.....	14
<b>8</b>	<b>DOCUMENT HISTORY AND MODIFICATION</b> .....	<b>15</b>



## 1 Data

(valid for BMD040 only, not for module)

### 1.1 Maximum ratings of pressure sensor

Parameter	Condition	Value	Unit	Max. time
Supply Voltage	$U_{S,max.}$	16	V	1 min
Pressure (burst pressure)	$p_{abs,max.}$	9000	kPa	1 min
Proven pressure	$P_{prov}$	4500	kPa	1 min.
Temperature	$t$	-40/+130	°C	100 h
Storage Temperature	$T$	-30/+120	°C	< 6 weeks

The output is resistant to short circuit to 0 V respectively 5 V. The sensor is resistant to reverse voltage for 5 min at room temperature, as the maximum current is limited to 0.3 A.

### 1.2 Operating characteristics of pressure sensor

Parameter	Symbol	Value			Unit
		min.	typ.	max.	
Pressure range	$p_{abs}$	50		3000	kPa
Temperature range	$t$	-30		100	°C
Supply voltage	$U_S$	4.75	5.0	5.25	V
Supply current at $U_S = 5\text{ V}$	$I_S$	6.0	9.0	12.5	mA
Output load current	$I_L$	-1.0		0.5	mA
Load resistance to $U_S$ or to ground	$R_{pull-up}$ $R_{pull-down}$	5.0 10.0			kΩ kΩ
Load capacitance	$C_L$			12	nF
Response time	$T_{10/90}$			1.0	ms
Lower limit at $U_S = 5\text{ V}$	$U_{out,min.}$	0.25	0.3	0.35	V
Upper limit at $U_S = 5\text{ V}$	$U_{out,max.}$	4.65	4.7	4.75	V
Output resistance to ground, $U_S$ open <sup>1)</sup>	$R_{io}$	2.4	4.7	8.2	kΩ
Output resistance to $U_S$ , ground open <sup>1)</sup>	$R_{hi}$	3.4	5.3	8.2	kΩ

1) valid only for measuring voltage < 0.5V

### 1.3 Signal evaluation

The pressure sensor supplies an analogue output signal, which is ratiometric to the supply voltage. An RC low-pass filter with for instance  $\tau = 2\text{ms}$  is recommended as an input circuitry for the following electronics in order to suppress possibly disturbing harmonic vibrations.

The output voltage of the CLK PIN (to be measured using a high input impedance  $> 2\text{M}\Omega$ , e.g. buffer with subsequent filtering) is decreasing with increasing temperature.

Proper signal evaluation is performed by applying 10nF capacitors between VDD and GND and between OUT and GND. Maximum total capacitive load on the OUT-pin must be below 25nF (including the 10nF mentioned before).

### 1.4 Signal range check

The electric output of the sensor is designed in such a way, that failures in function by cable breaks or short circuits can be detected by a suitable input circuitry of the following electronics. For the signal range check the diagnosis ranges beyond the characteristic limits are provided. Example of circuitry for detection of several kinds of failures by signal out of characteristic limits:

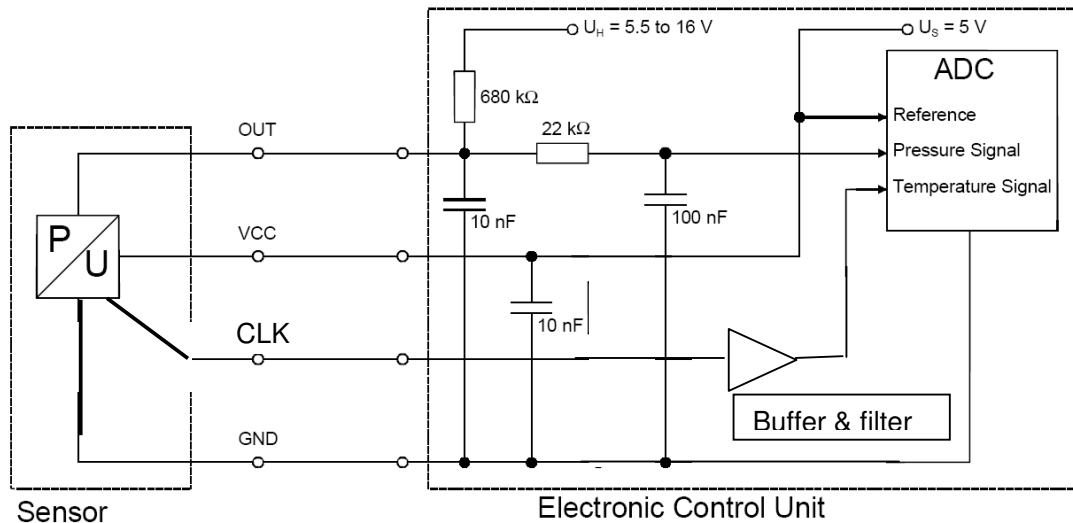

Figure 1. Application note (example)



### 1.5 Transfer function of pressure sensor

$$U_{\text{out}} = (c_1 \cdot p_{\text{abs}} + c_0) \cdot U_{\text{S}}$$

where  $U_{\text{out}}$  = signal output voltage in V  
 $U_{\text{S}}$  = supply voltage in V  
 $p_{\text{abs}}$  = absolute pressure in kPa  
 $c_0$  = 0.0864407  
 $c_1$  = 0.0002712

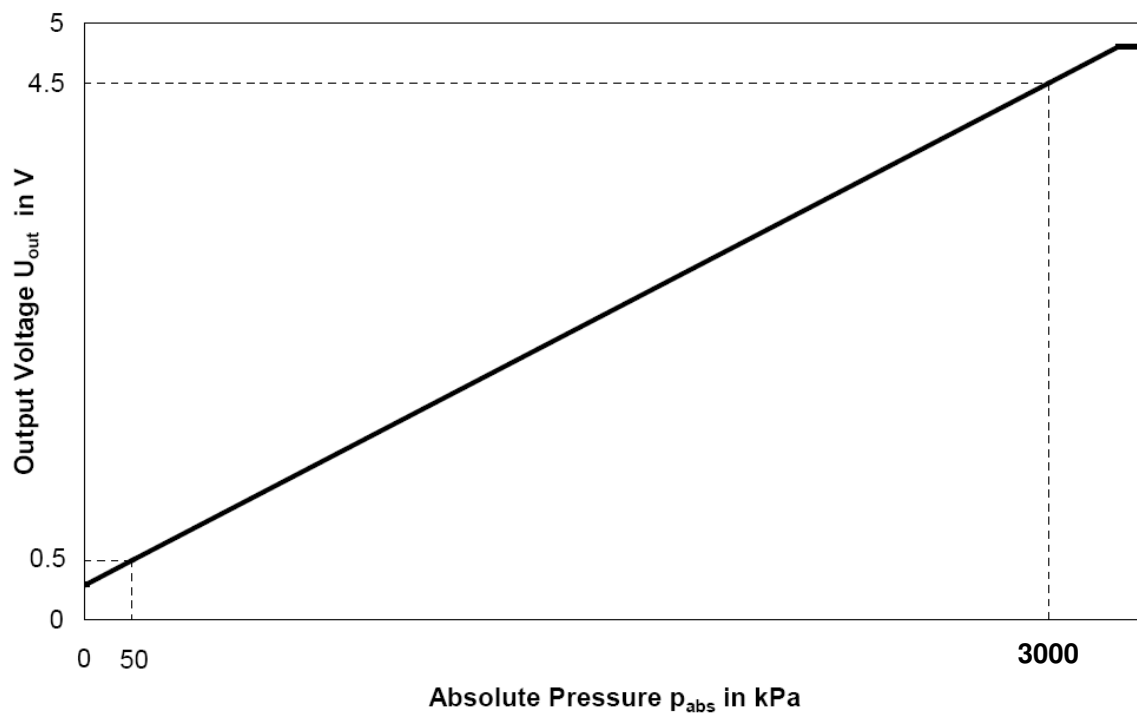

Figure 2. Characteristics at  $U_{\text{S}} = 5.000$  V (schematic view)

### 1.6 Accuracy of pressure sensor

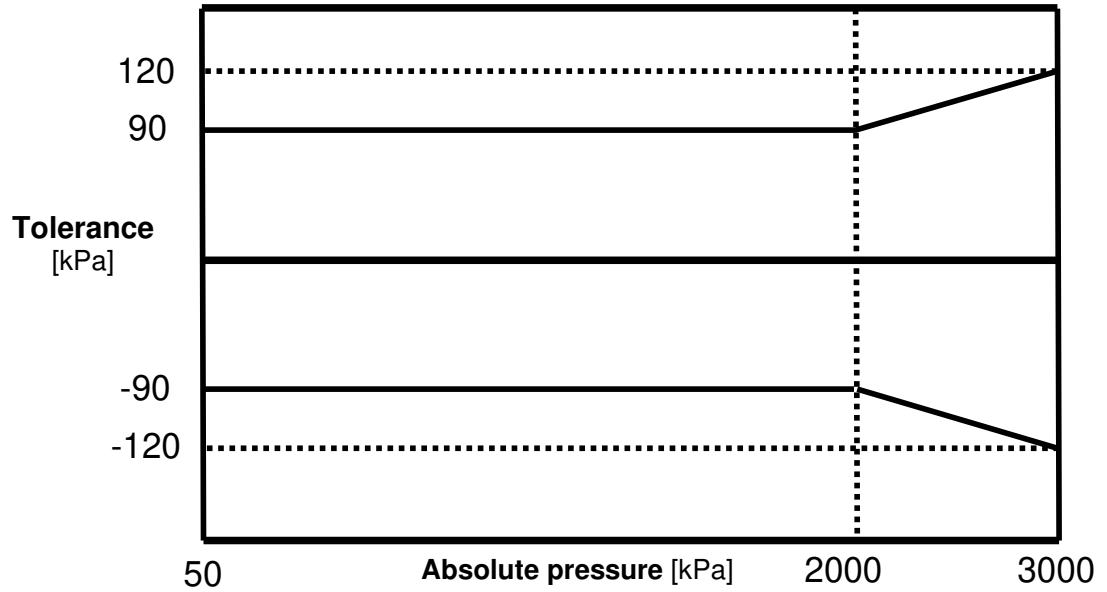

Figure 3. Characteristic tolerance (2s values)

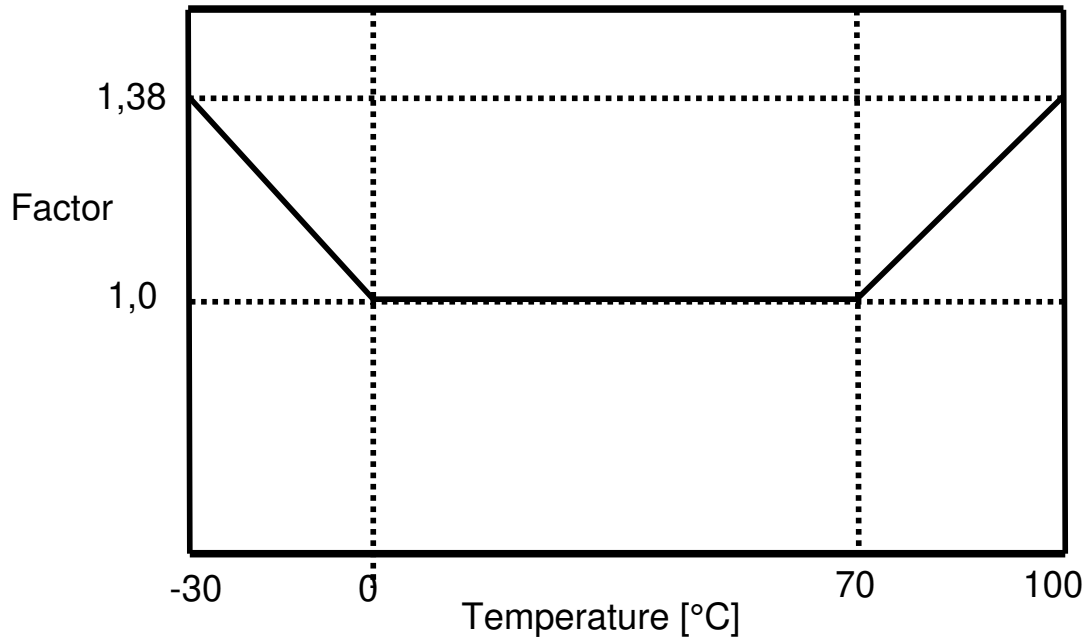



Figure 4. Tolerance broadening as a function of temperature (schematic view)



 <b>BOSCH</b>	<b>Data sheet</b> <b>BMD040</b>	Bosch Sensortec
--	------------------------------------	-----------------

Including all temperature and pressure tolerances a total tolerance over the whole temperature and pressure range of in total  $\pm 4,75\%$  as 2s-value has to be taken into account.

### 1.7 Data of CLK PIN

- $U_{CLK}$  is 4 times threshold voltage of one diode without additional measures for temperature compensation, linearization, etc.
- $U_{CLK}$  gives an indication about temperature dependence
- Measurement of  $U_{CLK}$  should be using a high ohmic impedance (e. g. buffer), subsequent filtering is recommended

### 1.8 Typical temperature dependence of CLK-PIN (schematic)

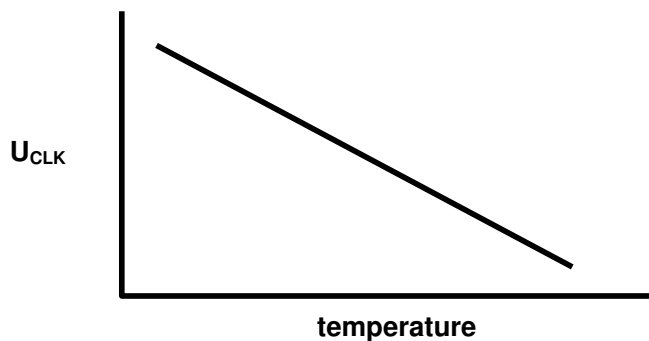



Figure 5. Characteristic  $U_{CLK} = f(t)$ , typical behaviour

- Typical dependence of output voltage is approximately  $-8\text{mV/K}$
- Typical output voltage range of CLK pin at room temperature is 2.6V to 3.0V

 <b>BOSCH</b>	<b>Data sheet BMD040</b>	Bosch Sensortec
--	------------------------------	-----------------

## 2 Installation instructions

The sensor is designed for attachment to a plane surface. The pressure nozzle might be sealed in some applications by an O-ring and might be fixed to a PCB or something similar. The hole in the fixture on customer side and the fastening must be designed in accordance to the offer drawing so that a long-term, leak proof seal at the port to the measured medium are guaranteed (if leakage is required).

The recommended installation position is pressure port inclined downwards, installation only on clean side. Potentially freezing media and condensate are not allowed to accumulate at the pressure port and may not be introduced on transport and assembly either.

In the interest of good continuity on the connectors, it is essential that not only the connector on the component side is according to specification, but that the material quality and exact fit of a cable harness connector (if such one is used) or another connector are also guaranteed. Any connector should therefore be according to the Bosch Sensortec offer drawing specification.

When mounting the BMD040 to a printed circuit board (PCB) special care has to be taken in order to stay below a certain temperature budget during the soldering process. For further details on the recommended soldering conditions for the BMD040, please contact Bosch Sensortec.

 <b>BOSCH</b>	<b>Data sheet</b> <b>BMD040</b>	Bosch Sensortec
--	------------------------------------	-----------------

### 3 Assembly installation

In order to avoid deterioration or pre-damage of the sensor at the user following points have to be absolutely noticed:

- a) It has to be ensured that the O-ring (if an O-ring is used) will not be damaged at assembly. Only a thin film of 'Shell Ondina Oil 68' or light engine oil (5W20) may be applied as lubricant. Don't use silicone based lubricants.
- b) The sensor must not be mounted with striking tools (e.g. hammer). The maximum allowed force at the pins is 10N. In order to avoid leakage through the glass isolation around the pins, use as low as possible forces.
- c) When the assembly unit is exposed to a leakage test, don't exceed maximum overpressure.
- d) At immersion test plug connector and pressure port for protection against water ingress.
- e) Avoid reverse voltage and over-voltage when electrical tests are applied to the sensor.
- f) It is recommended to keep the distance between the TO-8-bottom plate and the PCB at approximately 1.8 ... 2.0mm (see figure 7 and figure 8), which is the thickness of the square metal part at the bottom plate. This part is holding the pressure pipe. This mounting condition prevents possible shortcuts between the electrical connections (TO-8 housing is connected to GND).
- g) It has to be ensured, that pressure is only applied via the pressure pipe, since above a certain pressure, the metal cap will start to bend. This critical pressure level is slightly above the full scale pressure range.
- h) The sensor is sensitive to temperatures above 170°C, thus temperatures above this value at the TO8-cell (not at the pins) must be avoided.

As a consequence:

- (1) Reflow soldering of the sensor is forbidden, since too high temperatures may occur. By using hand or dip soldering of the pins the temperature at the pins may exceed 170°C, but not in the inner part of the sensor. For checking the temperature of the housing, a thermo couple or temperature probe could be used.
- (2) The pressure of the measured media has to be applied via the pressure pipe. Thus this pressure pipe has to be connected to the device (e. g. an air-conditioner) without leakage. This could be done by using an O-ring or laser welding or soldering. Depending on the pressure range some methods are not feasible (e. g. O-Ring for 30 bar applications). If laser welding or soldering is used, the same temperature restriction is valid as described in (1), but in this case the pressure pipe is introducing the temperature.
- (3) A dedicated assessment of the influence of the implementation method (O-Ring, soldering, welding, etc.) could be done together with Bosch Sensortec in order to ensure proper assembly and to avoid damage of the sensor.

If the installation of the sensor takes place at the supplier e.g. of an assembly unit, the supplier has to be instructed accordingly.

If the pressure sensor is removed after field use from the interface of an assembly unit e.g. rail, the sensor has to be replaced by a new sensor to guarantee tightness.

 <b>BOSCH</b>	<b>Data sheet BMD040</b>	Bosch Sensortec
--	------------------------------	-----------------

#### 4 Maximum storage time

Maximum storage time: 3 years  
Storage temperature: 0 ... 40°C  
Relative humidity: 40... 60%

Short-term exceeding of storage conditions is possible (see maximum ratings).

Protecting against external effect (i.e. precipitation, vapor)



## 5 Pin assignment

- A = supply (+5 V)
- B = ground (contacted to TO-8 can)
- C = pressure output
- CLK = temperature output, high impedance, can be connected to ground if not used
  
- UP1 = programming pin, can be connected to ground
- UP2 = programming pin, can be connected to ground

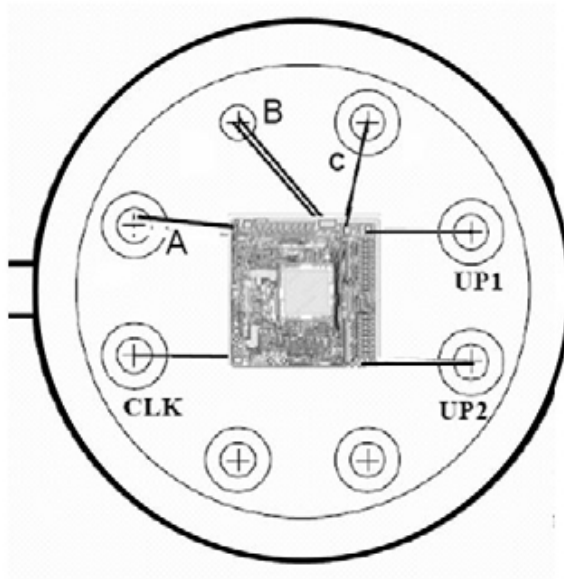

Figure 6: Pin assignment – view from above

**6 Package**

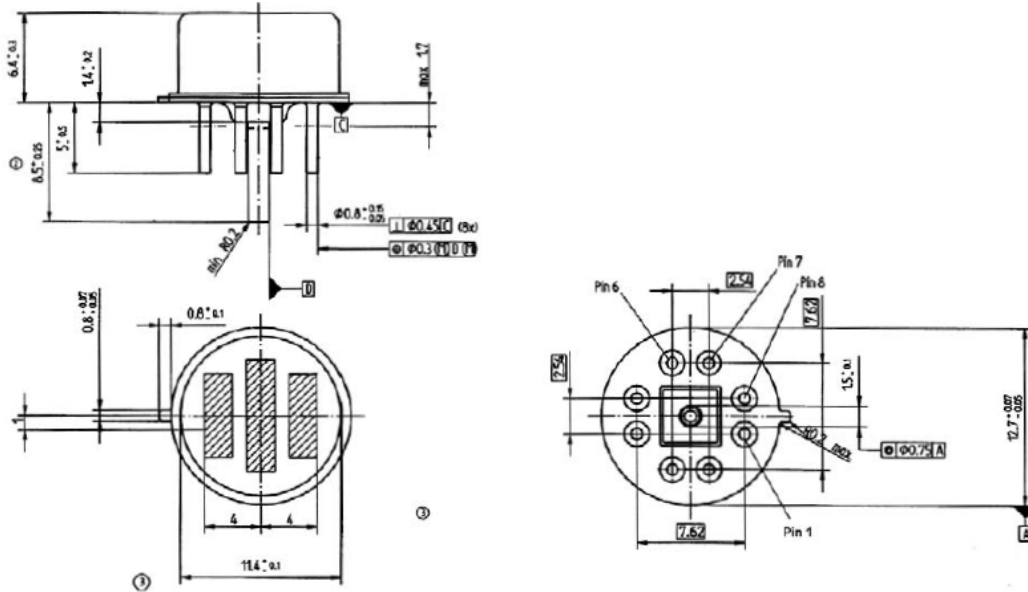

Figure 7: Package dimensions (all in mm), type writing is in the hatched area

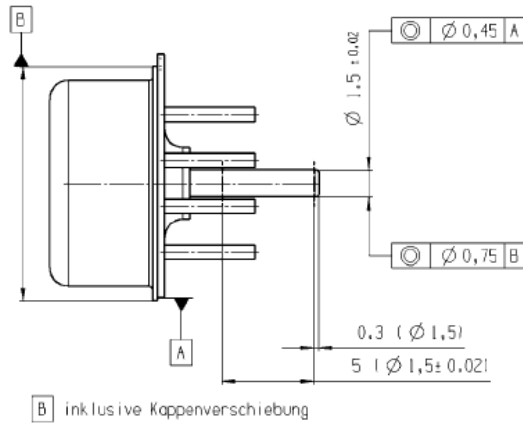



Figure 8: Pressure supply pipe with tolerance data (all in mm)



 <b>BOSCH</b>	<b>Data sheet BMD040</b>	Bosch Sensortec
--	------------------------------	-----------------

## 7 Legal disclaimer

### 7.1 Product use

Bosch Sensortec products are developed for the consumer goods industry. They may only be used within the parameters of this product data sheet. Bosch Sensortec products are provided with the express understanding that there is no warranty of fitness for a particular purpose. They are not fit for use in life-sustaining, safety or security sensitive systems or any system or device that may lead to bodily harm or property damage if the system or device malfunctions. In addition, Bosch Sensortec products are not fit for use in products which interact with motor vehicle systems.

The resale and/or use of products are at the purchaser's own risk and his own responsibility. The examination of fitness for the intended use is the sole responsibility of the Purchaser.

The purchaser shall indemnify Bosch Sensortec from all third party claims, including any claims for incidental, or consequential damages, arising from any product use not covered by the parameters of the respective valid product data sheet or not approved by Bosch Sensortec and reimburse Bosch Sensortec for all costs in connection with such claims.

The purchaser must monitor the market for the purchased products, particularly with regard to product safety and inform Bosch Sensortec without delay of all security relevant incidents.

### 7.2 Engineering samples

Engineering Samples are marked with an asterisk (\*) or (e). Samples may vary from the valid technical specifications of the product series contained in this data sheet. They are therefore not intended or fit for resale to third parties or for use in end products. Their sole purpose is internal client testing. The testing of an engineering sample may in no way replace the testing of a product series. Bosch Sensortec assumes no liability for the use of engineering samples. By accepting the engineering samples, the Purchaser agrees to indemnify Bosch Sensortec from all claims arising from the use of engineering samples.

### 7.3 Application examples and hints

With respect to any examples or hints given herein, any typical values stated herein and/or any information regarding the application of the device, Bosch Sensortec hereby disclaims any and all warranties and liabilities of any kind, including without limitation warranties of non-infringement of intellectual property rights or copyrights of any third party. The information given in this document shall in no event be regarded as a guarantee of conditions or characteristics. They are provided for illustrative purposes only and no evaluation regarding infringement of intellectual property rights or copyrights or regarding functionality, performance or error has been made.

 <b>BOSCH</b>	<b>Data sheet BMD040</b>	Bosch Sensortec
--	------------------------------	-----------------

## 8 Document history and modification

Rev. No	Chapter	Description of modification/changes	Date
1.0		Initial version	05-June-07
1.1	Title	Introduced part number	26-Oct-2007
	1.6	Added some comments on tolerance values	26-Oct-2007
1.2	3	Modified and added assembly recommendations	03-Dec-2007
	7	Update of legal disclaimer	03-Dec-2007
	1	Added storage temp, increase temp.-range	16-Jan-2008
1.3	1.3	Added info on external 10nF capacitors	23-Oct-2008

Bosch Sensortec GmbH  
 Gerhard-Kindler-Strasse 8  
 72770 Reutlingen / Germany

contact@bosch-sensortec.com  
[www.bosch-sensortec.com](http://www.bosch-sensortec.com)

Modifications reserved | Printed in Germany  
 Specifications subject to change without notice  
 Document-number: BST-BMD040-DS000-03  
 Version\_1.3\_102008