



Chipsmall Limited consists of a professional team with an average of over 10 year of expertise in the distribution of electronic components. Based in Hongkong, we have already established firm and mutual-benefit business relationships with customers from,Europe,America and south Asia,supplying obsolete and hard-to-find components to meet their specific needs.

With the principle of "Quality Parts,Customers Priority,Honest Operation,and Considerate Service",our business mainly focus on the distribution of electronic components. Line cards we deal with include Microchip,ALPS,ROHM,Xilinx,Pulse,ON,Everlight and Freescale. Main products comprise IC,Modules,Potentiometer,IC Socket,Relay,Connector.Our parts cover such applications as commercial,industrial, and automotives areas.

We are looking forward to setting up business relationship with you and hope to provide you with the best service and solution. Let us make a better world for our industry!



## Contact us

Tel: +86-755-8981 8866 Fax: +86-755-8427 6832

Email & Skype: info@chipsmall.com Web: www.chipsmall.com

Address: A1208, Overseas Decoration Building, #122 Zhenhua RD., Futian, Shenzhen, China



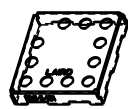

ISO VIEW  
REF ONLY

SCALE 1.000

13,66 ± 0.10 [[0.004]  
[0.538]



11,70  
[0.461]

8,45  
[0.333]

5,20  
[0.205]

1,95  
[0.077]

0,00  
[0.000]

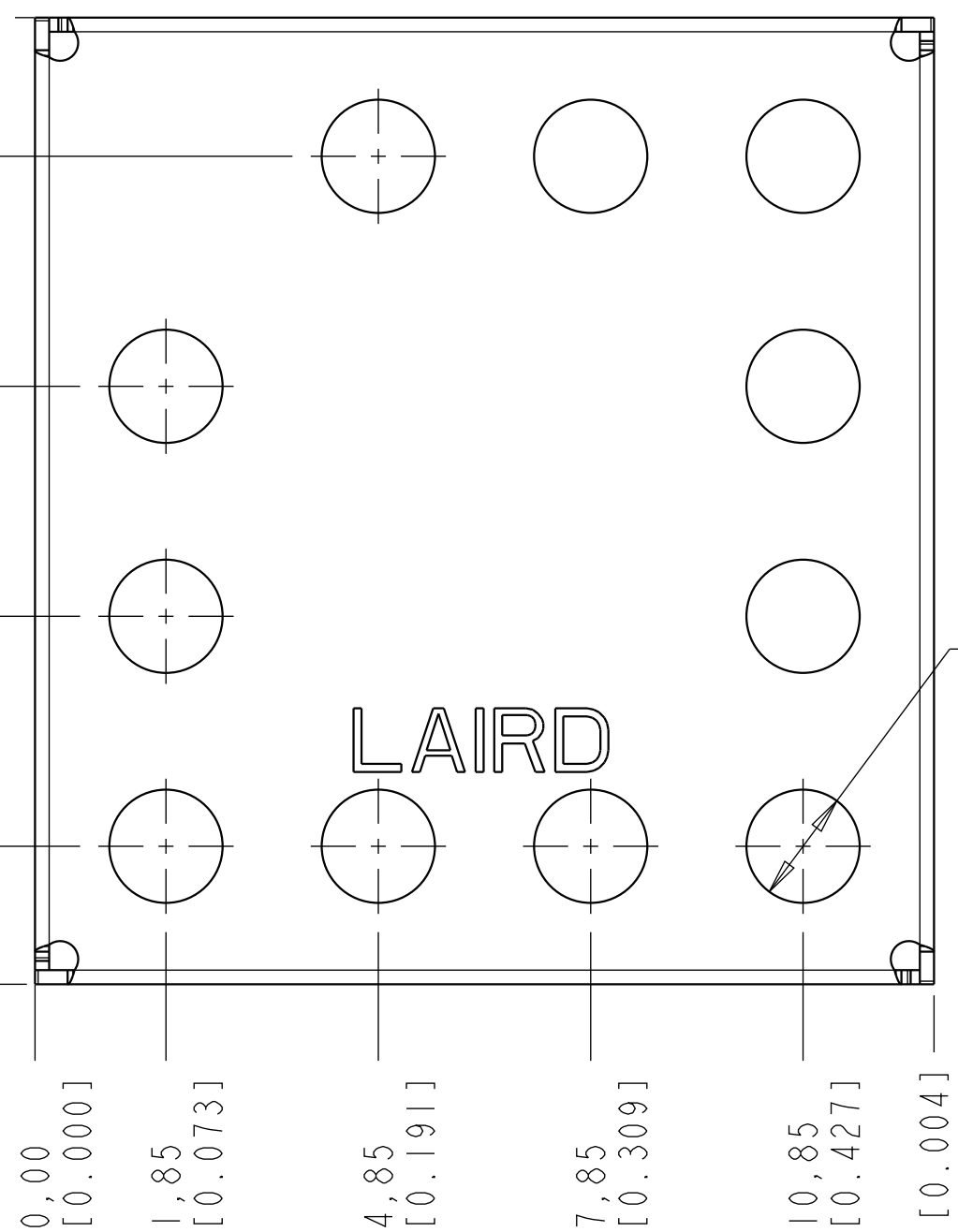

0,50  
[0.020] TYP

11X Ø 1,60  
[0.063]

12,70 ± 0.10 [[0.004]  
[0.500]

2,54  
[0.100]

0,100 [0.0039]

ALL SURFACES

ALL DIMENSIONS ARE  
IN MILLIMETERS [INCHES]

TOLERANCES UNLESS SPECIFIED

0.50 - 6.00	±0.10
6.00 - 30.00	±0.20
30.00 - 120.00	±0.30
120.00 - 400.00	±0.50
Ø HOLE	±0.10
ANGULAR TOL.	±1°

THIRD ANGLE  
PROJECTION

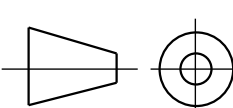

REVISION CHANGES				
REV	DESCRIPTION	DATE	BY	APPROVED
T1	RELEASE FOR PRODUCTION	12/09/02	ARZ	
T2	CHANGED ETCHED BMI TO LAIRD	03/08/05	ARZ	RJR
3	ADDED DUAL DIMS 7 CARRIER TAPE [E5455]	06/12/06	RCB	DG
4	P/N WAS BMIS-101 & ADDED PACK TO 2ND SHT	08/16/07	GRE	IV

NOTES:

- MATERIAL SPECIFICATIONS:
  - MATERIAL:  
THICKNESS = 0.20 [0.008] ±0.02 [0.0008]  
TYPE: CRS 1/2 HARD
  - SURFACE FINISH:  
1.25 - 3.75 MICRONS [0.000049-0.000148]  
100% MATTE TIN
- TOLERANCE/APPEARANCE:
  - NO CHANGE IN PRODUCTION MATERIAL SHALL BE ALLOWED WITHOUT EXPLICIT PRIOR WRITTEN APPROVAL FROM LAIRD TECHNOLOGIES ENGINEERING DEPARTMENT.
  - PARTS SHALL BE FREE OF SHARP EDGES. BURRS SHALL NOT EXCEED 10% OF MATERIAL THICKNESS OR 0.15mm WHICHEVER IS LESS.
  - REFERENCE DIMENSIONS, SHOWN IN PARANTHESES (DIM), ARE WITHOUT TOLERANCE AND ARE FOR INFORMATION PURPOSES ONLY.
  - CRITICAL DIMENSIONS ARE DESIGNATED BY
  - ALL RADII ARE TO BE R0.25 UNLESS OTHERWISE SPECIFIED.
  - PART SHALL BE FREE OF OIL OR GREASE
- PACKAGING:
  - SEE SHEET 2 OF 2



1751 WILKENING COURT  
SCHAUMBURG, IL 60173

TITLE: LT BOARD LEVEL SHIELD - STANDARD PRODUCT

CUSTOMER: PROJECT: CATALOG DATE: 12/06/97  
CUST. ENGR. PART NO. BMI-S-101

DRAWN BY: ARZ SCALE: 10.000 SYSTEM: PRO/E DWG SIZE C

APP'D BY: ARZ SHEET NO. 1 OF 2 FILE: BMI-S-101 REV. 4

DO NOT  
SCALE PRINT

CONFIDENTIAL

This print is the property of Laird Tech. and is loaned in confidence subject to return upon request and with the understanding that no copies shall be made without the written consent of Laird Tech. All rights to design or invention are reserved.

CARRIER TAPE WIDTH: 24 MM  
 CARRIER TAPE PITCH: 20 MM  
 REEL DIAMETER: 330 MM  
 PARTS PER REEL: 1000

REVISION CHANGES				
REV	DESCRIPTION	DATE	BY	APPROVED
T1	SEE SHEET 1	12/09/02	ARZ	
T2	SEE SHEET 1	03/08/05	ARZ	RJR
3	ADDED DUAL DIMS 7 CARRIER TAPE [E5455]	06/12/06	RCB	DG
4	P/N WAS BMIS-101 & ADDED PACK TO 2ND SHT	08/16/07	GRE	IV

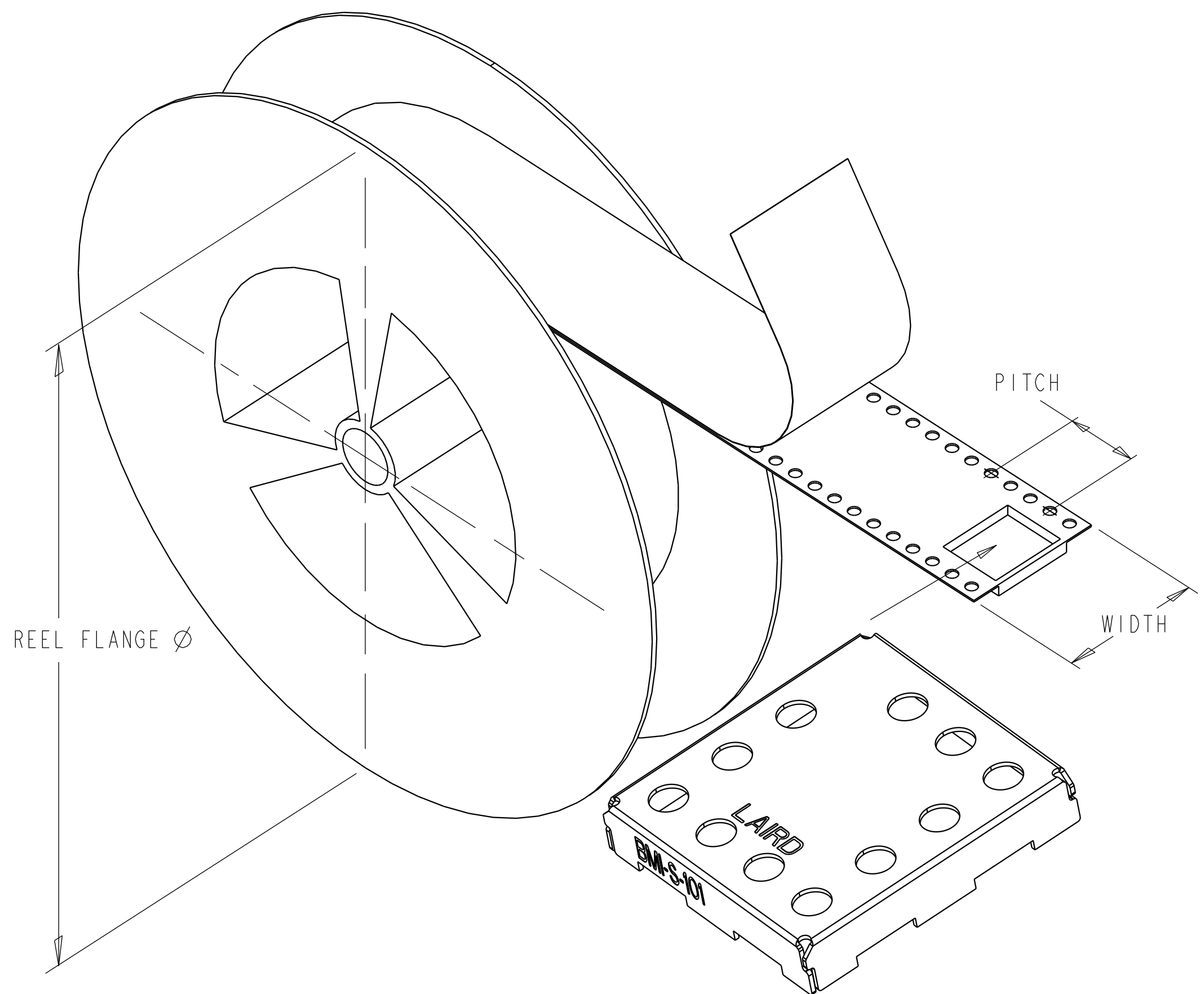
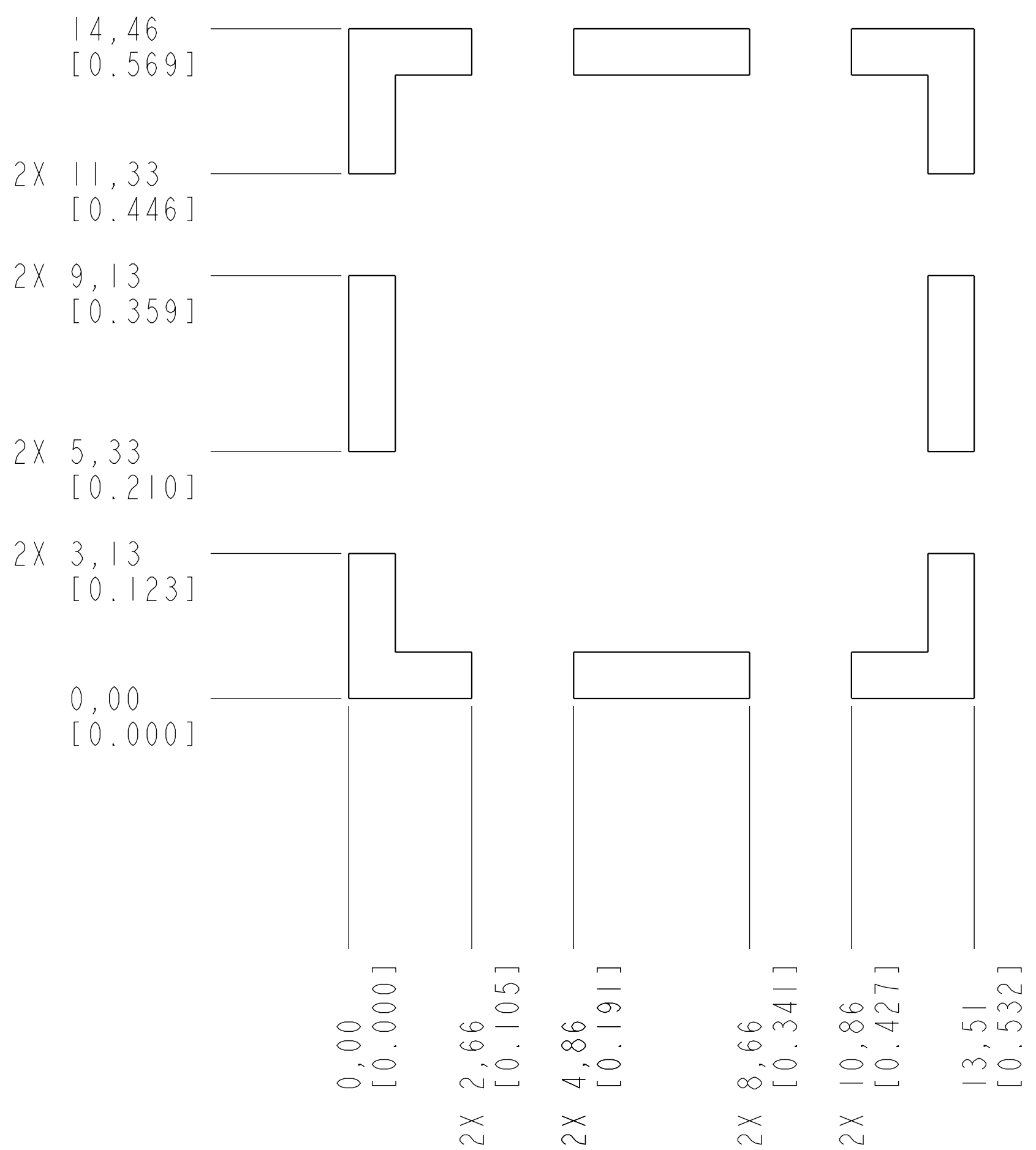

ALL DIMENSIONS ARE IN MILLIMETERS



1751 WILKENING COURT  
 SCHAUMBURG, IL 60173

TITLE: LT BOARD LEVEL SHIELD - STANDARD PRODUCT

TOLERANCES UNLESS SPECIFIED	
X.X ONE PLC	±0.25
X.XX TWO PLC	±0.13
∅ HOLE	±0.10
ANGULAR TOL.	±1°

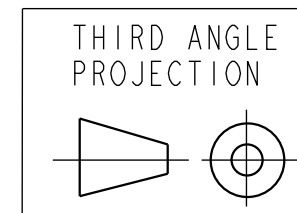

CUSTOMER:		CUST. ENGR.	PART NO. BMI-S-101	
PROJECT:	DATE:	12/06/97		
DRAWN BY: ARZ	SCALE:	7.000	SYSTEM: PRO/E	DWG SIZE REV.
APP'D BY: ARZ	SHEET NO.	2 OF 2	FILE: BMI-S-101	C 4

DO NOT SCALE PRINT

LAIIRD TECH. COPYRIGHT 2002

THE DRAWING ON THIS PRINT AND INFORMATION THEREWITH ARE PROPRIETARY TO LAIRD TECH, AND SHALL NOT RE USED OR DISCUSSED INWHOLE OR IN PART WITHOUT LAIRD TECH'S CONSENT.