



Chipsmall Limited consists of a professional team with an average of over 10 year of expertise in the distribution of electronic components. Based in Hongkong, we have already established firm and mutual-benefit business relationships with customers from,Europe,America and south Asia,supplying obsolete and hard-to-find components to meet their specific needs.

With the principle of “Quality Parts,Customers Priority,Honest Operation,and Considerate Service”,our business mainly focus on the distribution of electronic components. Line cards we deal with include Microchip,ALPS,ROHM,Xilinx,Pulse,ON,Everlight and Freescale. Main products comprise IC,Modules,Potentiometer,IC Socket,Relay,Connector.Our parts cover such applications as commercial,industrial, and automotives areas.

We are looking forward to setting up business relationship with you and hope to provide you with the best service and solution. Let us make a better world for our industry!



Contact us

Tel: +86-755-8981 8866 Fax: +86-755-8427 6832

Email & Skype: info@chipsmall.com Web: www.chipsmall.com

Address: A1208, Overseas Decoration Building, #122 Zhenhua RD., Futian, Shenzhen, China



DESIGNED & DIMENSIONED
IN MILLIMETERS [INCHES]

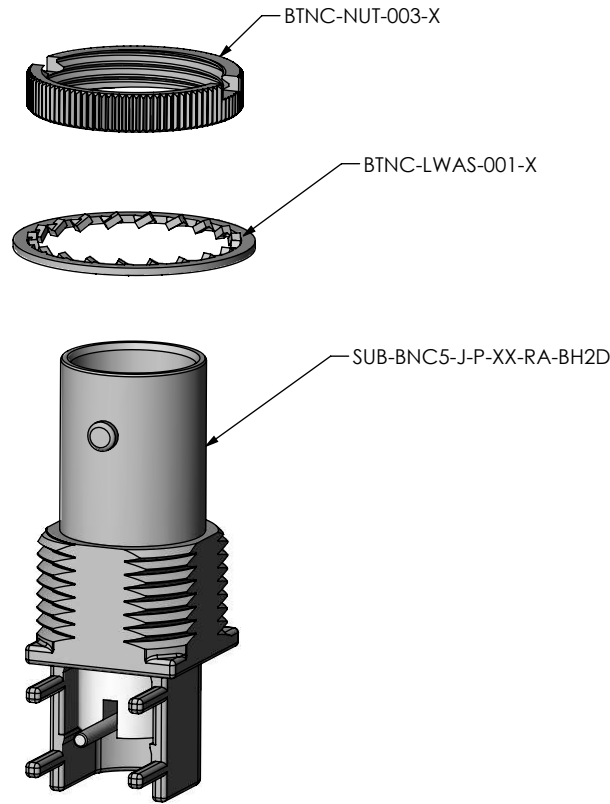

BNC5-J-P-XX-RA-BH2D

SERIES
BNC 50 OHM

GENDER
-J: JACK

TYPE
-P: PCB

TERMINATION
-BH2D: DIE CAST BULKHEAD THROUGH HOLE

ORIENTATION
-RA: RIGHT ANGLE

PLATING SPECIFICATION
-HN: HEAVY GOLD/NICKEL (SEE NOTES 3 & 4)
(SUB-BNC5-J-P-HN-RA-BH2D)
(BTNC-NUT-003-N)
(BTNC-LWAS-001-N)

-GN: GOLD/NICKEL (SEE NOTES 3 & 4)
(SUB-BNC5-J-P-GN-RA-BH2D)
(BTNC-NUT-003-N)
(BTNC-LWAS-001-N)

RECOMMENDED MOUNTING HOLE
4.00 [1.57] MAX. PANEL THICKNESS

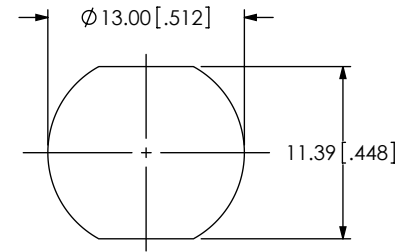

RECOMMENDED PCB LAYOUT

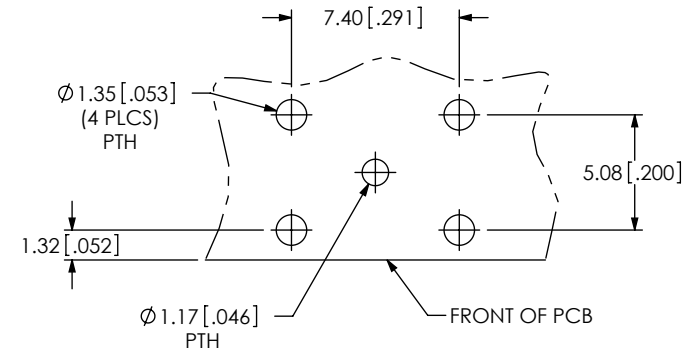

NOTES: **C**

- ⊗ REPRESENTS A CRITICAL DIMENSION.
- RoHS COMPLIANT.
- COMPONENT PLATING DESIGNATIONS:
-H: 0.000030" MIN. GOLD OVER 0.000050" MIN. NICKEL.
-G: 0.000010" MIN. GOLD OVER 0.000050" MIN. NICKEL.
-N: 0.000100" MIN. NICKEL.
- ASSEMBLY PLATING DESIGNATIONS:
-HN: (CENTER CONTACT)-H
(OUTER CONTACT) -N
(REMAINING METAL PARTS) -N
-GN: (CENTER CONTACT)-G
(OUTER CONTACT) -N
(REMAINING METAL PARTS) -N
- SEE CO-HD-WI-3040-M RF PACKAGING STANDARD FOR PACKAGING INSTRUCTIONS.
PRODUCT TO BE PACKAGED IN TRAY TY-BNC001-1 WITH COVER TY-BNC002-2.
- NUT AND WASHER TO BE PACKAGED SEPARATELY.

**THIS PRODUCT MANUFACTURED
WITH LEAD-FREE PROCESSING**

UNLESS OTHERWISE SPECIFIED,
DIMENSIONS ARE IN
MILLIMETERS [INCHES].
TOLERANCES ARE:
DECIMALS ANGLES
.X: ±0.3 [01] 5°
.XX: ±0.13 [005]
.XXX: ±0.051 [0020]

PROPRIETARY NOTE
THIS DOCUMENT CONTAINS INFORMATION
CONFIDENTIAL AND PROPRIETARY TO
SAMTEC, INC. AND SHALL NOT BE REPRODUCED
OR TRANSFERRED TO OTHER DOCUMENTS OR
DISCLOSED TO OTHERS OR USED FOR ANY
PURPOSE OTHER THAN THAT WHICH IT WAS
OBTAINED WITHOUT THE EXPRESSED WRITTEN
CONSENT OF SAMTEC, INC.

samtec
520 PARK EAST BLVD, NEW ALBANY, IN 47150
PHONE: 812-944-6733 FAX: 812-948-5047
e-Mail: info@SAMTEC.com code: 55322

MATERIAL: DO NOT SCALE DRAWING SHEET SCALE: 2:1
SHELL: ZINC
NUT, WASHER: BRASS
CONTACT: PHOS BRONZE
DIELECTRIC: PTFE

DESCRIPTION:
BNC 50 OHM RIGHT ANGLE JACK
DWG. NO.
BNC5-J-P-XX-RA-BH2D
BY: ALVIN W 07/01/2010 SHEET 1 OF 2

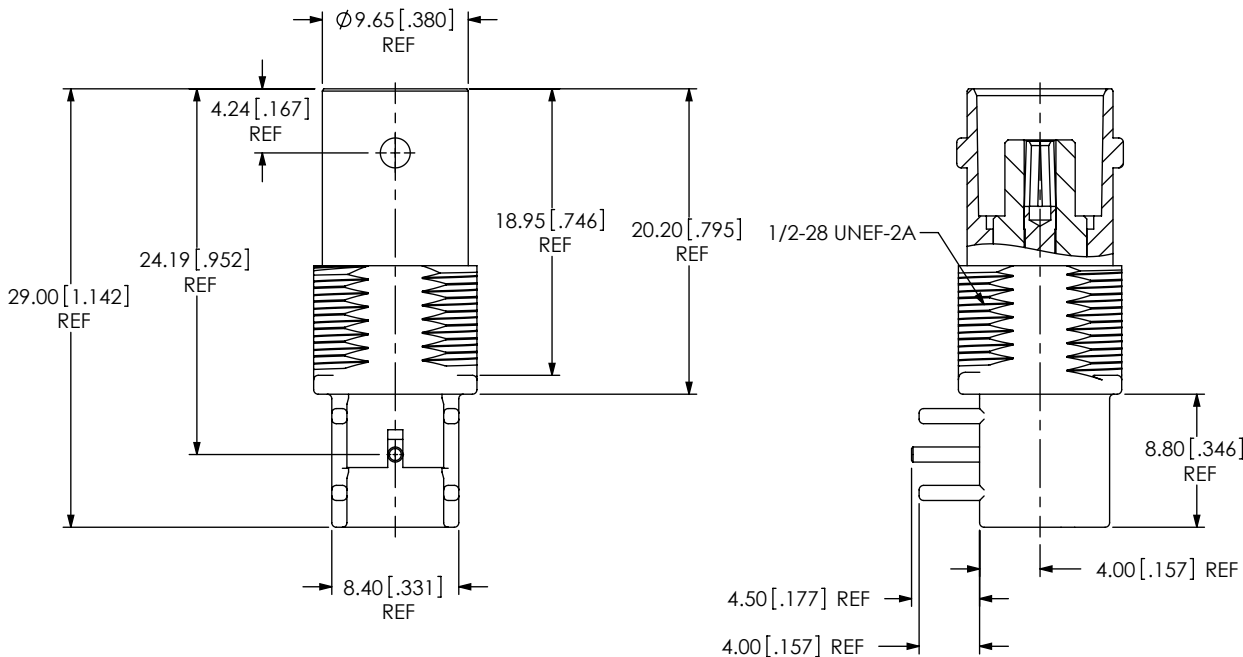
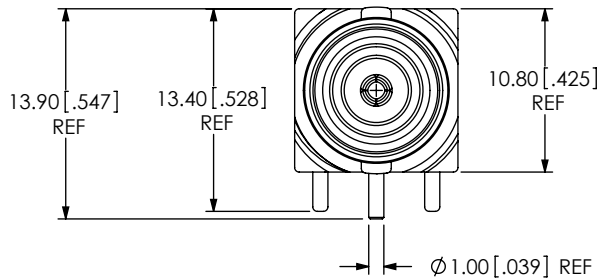

SAMTEC PART NUMBER	ITEM
SUB-BNC5-J-P-XX-RA-BH2D	SUB ASSEMBLY

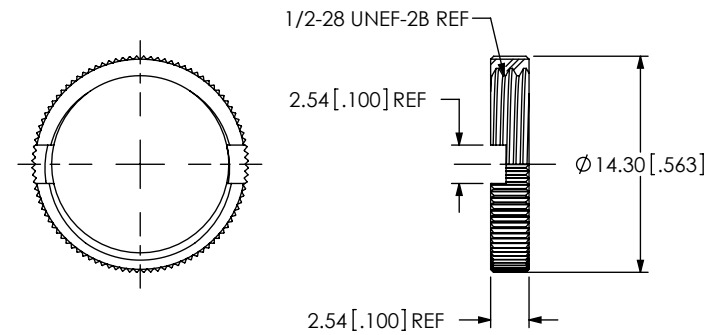

SAMTEC PART NUMBER	ITEM
BTNC-NUT-003-X	KNURLED NUT

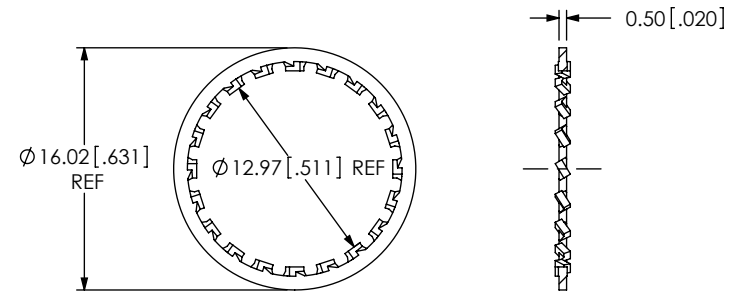

SAMTEC PART NUMBER	ITEM
BTNC-LWAS-001-X	LOCK WASHER

PROPRIETARY NOTE
 THIS DOCUMENT CONTAINS INFORMATION CONFIDENTIAL AND PROPRIETARY TO SAMTEC, INC. AND SHALL NOT BE REPRODUCED OR TRANSFERRED TO OTHER DOCUMENTS OR DISCLOSED TO OTHERS OR USED FOR ANY PURPOSE OTHER THAN THAT WHICH IT WAS OBTAINED WITHOUT THE EXPRESSED WRITTEN CONSENT OF SAMTEC, INC.

DO NOT SCALE DRAWING

SHEET SCALE: 2:1

samtec

520 PARK EAST BLVD, NEW ALBANY, IN 47150
 PHONE: 812-944-6733 FAX: 812-948-5047
 e-Mail: info@SAMTEC.com code: 55322

DESCRIPTION:
 BNC 50 OHM RIGHT ANGLE JACK

DWG. NO.
 BNC5-J-P-XX-RA-BH2D

BY: ALVIN W 07/01/2010 SHEET 2 OF 2