



Chipsmall Limited consists of a professional team with an average of over 10 year of expertise in the distribution of electronic components. Based in Hongkong, we have already established firm and mutual-benefit business relationships with customers from,Europe,America and south Asia,supplying obsolete and hard-to-find components to meet their specific needs.

With the principle of “Quality Parts,Customers Priority,Honest Operation,and Considerate Service”,our business mainly focus on the distribution of electronic components. Line cards we deal with include Microchip,ALPS,ROHM,Xilinx,Pulse,ON,Everlight and Freescale. Main products comprise IC,Modules,Potentiometer,IC Socket,Relay,Connector.Our parts cover such applications as commercial,industrial, and automotives areas.

We are looking forward to setting up business relationship with you and hope to provide you with the best service and solution. Let us make a better world for our industry!



Contact us

Tel: +86-755-8981 8866 Fax: +86-755-8427 6832

Email & Skype: info@chipsmall.com Web: www.chipsmall.com

Address: A1208, Overseas Decoration Building, #122 Zhenhua RD., Futian, Shenzhen, China



DO NOT SCALE FROM THIS PRINT

DESIGNED & DIMENSIONED IN MILLIMETERS [INCHES]

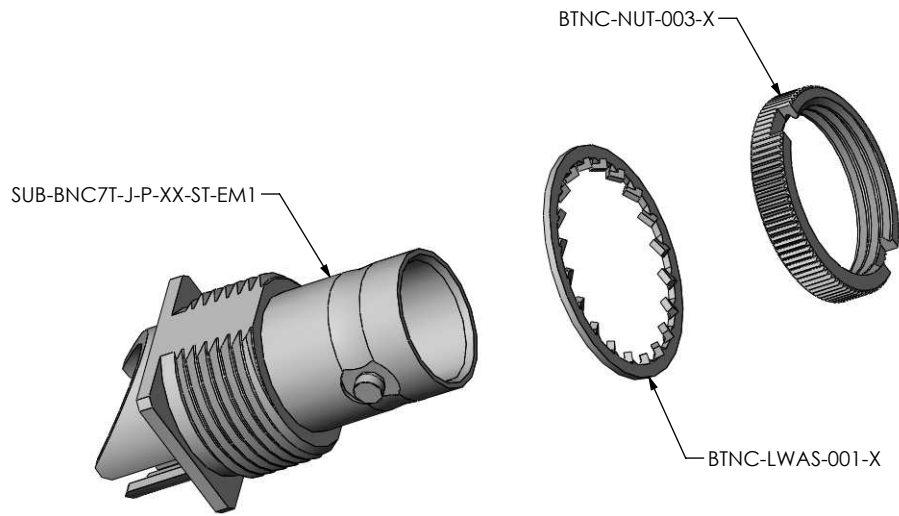
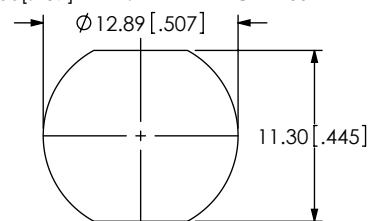

FIG 1
BNC7T-J-P-XX-ST-EM1 SHOWN

BNC7T-J-P-XX-ST-EM1

- GENDER
-J: JACK
- TERMINATION
-EM1: EDGE MOUNT (FOR 1.57[.062] THICK PCB)
- ORIENTATION
-ST: STRAIGHT
- PLATING SPECIFICATION
-HN: HEAVY GOLD/NICKEL (SEE NOTES 5 & 6)
(SUB-BNC7T-J-P-HN-ST-EM1)
(BTNC-NUT-003-N)
(BTNC-LWAS-001-N)
- GN: GOLD/NICKEL (SEE NOTES 5 & 6)
(SUB-BNC7T-J-P-GN-ST-EM1)
(BTNC-NUT-003-N)
(BTNC-LWAS-001-N)
- MN: MEDIUM GOLD/NICKEL (EXISTING CUSTOMERS ONLY)
(SUB-BNC7T-J-P-GN-ST-EM1)
(BTNC-NUT-003-N)
(BTNC-LWAS-001-N)
- TYPE
-P: PCB

RECOMMENDED MOUNTING HOLE
4.00[.157] MAX. PANEL THICKNESS



RECOMMENDED LAYOUT
FOR 1.57[.062] PCB

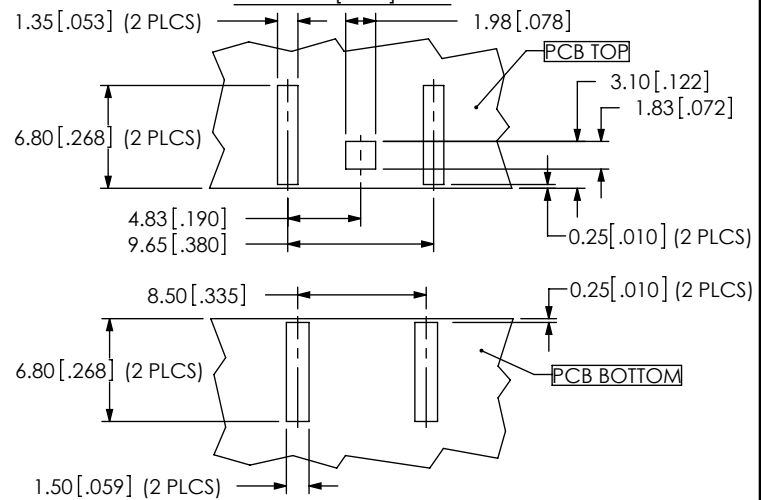

NOTES:

1. $\text{\textcircled{C}}$ REPRESENTS A CRITICAL DIMENSION.
2. FABRICATED PARTS MUST BE FREE OF SCRATCHES, TOOL MARKS, ETC.
3. SUPPLIER TO REMOVE BURRS.
4. RoHS COMPLIANT.
5. COMPONENT PLATING DESIGNATIONS:
-H: .000030" MIN. GOLD OVER .000050. (MIN) NICKEL.
-G .000010" MIN. GOLD OVER .000050" MIN. NICKEL
-N: .000100" MIN. NICKEL.
6. ASSEMBLY PLATING DESIGNATIONS:
-HN: (CENTER CONTACT)-H
(OUTER CONTACT) -N
(REMAINING METAL PARTS) -N
-GN, MN: (CENTER CONTACT)-G
(OUTER CONTACT) -N
(REMAINING METAL PARTS) -N

UNLESS OTHERWISE SPECIFIED, DIMENSIONS ARE IN MILLIMETERS. TOLERANCES ARE:
DECIMALS ANGLES
.X: ± 0.3 [.01] 2°
.XX: ± 0.13 [.005]
.XXX: ± 0.051 [.0020]

PROPRIETARY NOTE
THIS DOCUMENT CONTAINS INFORMATION CONFIDENTIAL AND PROPRIETARY TO SAMTEC, INC. AND SHALL NOT BE REPRODUCED OR TRANSFERRED TO OTHER DOCUMENTS OR DISCLOSED TO OTHERS OR USED FOR ANY PURPOSE OTHER THAN THAT WHICH IT WAS OBTAINED WITHOUT THE EXPRESSED WRITTEN CONSENT OF SAMTEC, INC.



520 PARK EAST BLVD, NEW ALBANY, IN 47150
PHONE: 812-944-6733 FAX: 812-948-5047
e-Mail: info@SAMTEC.com code: 55322

DO NOT SCALE DRAWING SHEET SCALE: 2:1

DESCRIPTION: BNC7T EDGE MOUNT STRAIGHT JACK
DWG. NO. BNC7T-J-P-XX-ST-EM1
BY: G.HERMAN 01/04/2008 SHEET 1 OF 2

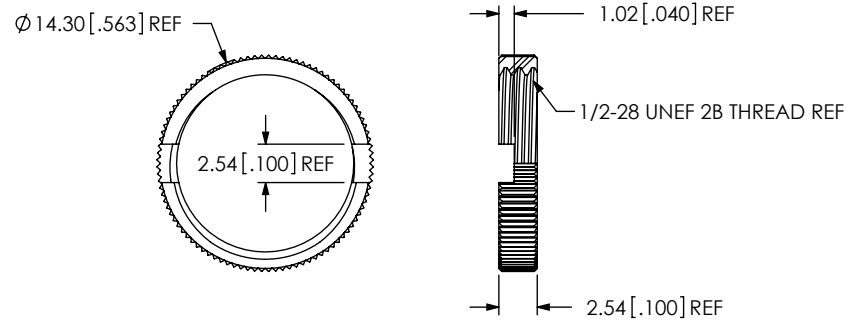
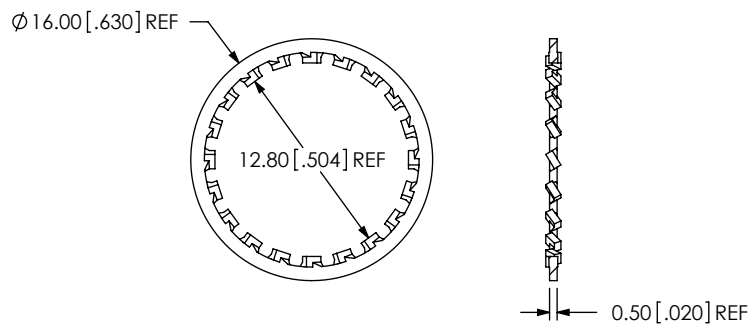

SAMTEC PART NUMBER	ITEM
BTNC-LWAS-001-X	LOCKWASHER

SAMTEC PART NUMBER	ITEM
BTNC-NUT-003-X	KNURLED NUT

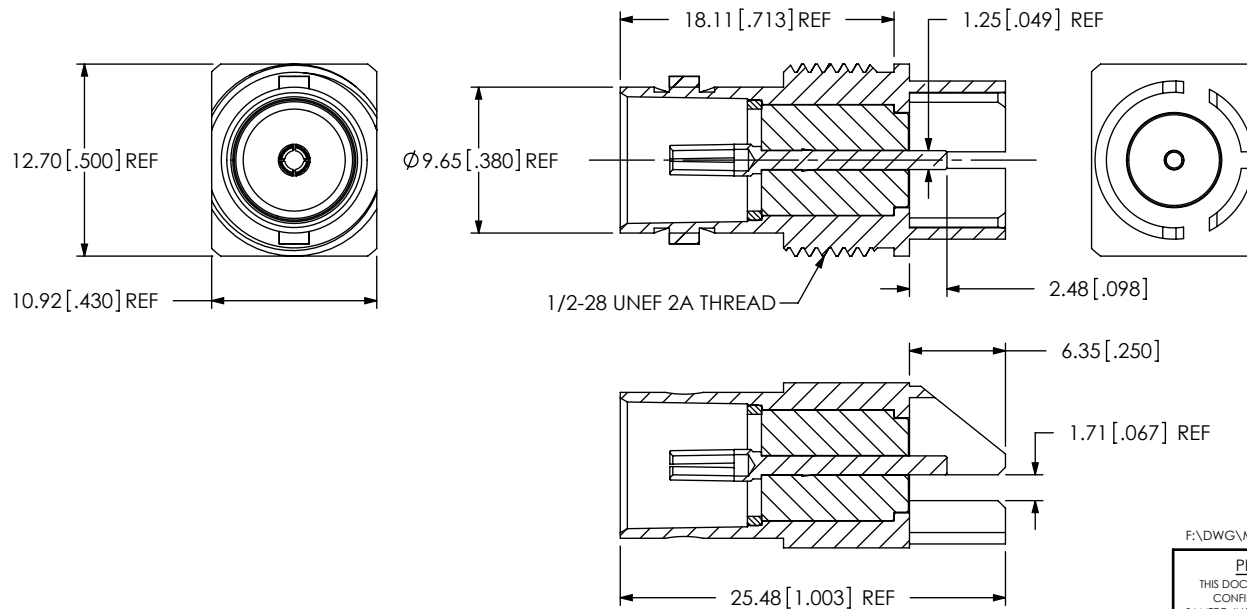

F:\DWG\MISC\MKTG\BNC7T-J-P-XX-ST-EM1-MKT.SLDDRW

PROPRIETARY NOTE
 THIS DOCUMENT CONTAINS INFORMATION
 CONFIDENTIAL AND PROPRIETARY TO
 SAMTEC, INC. AND SHALL NOT BE REPRODUCED
 OR TRANSFERRED TO OTHER DOCUMENTS OR
 DISCLOSED TO OTHERS OR USED FOR ANY
 PURPOSE OTHER THAN THAT WHICH IT WAS
 OBTAINED WITHOUT THE EXPRESSED WRITTEN
 CONSENT OF SAMTEC, INC.



520 PARK EAST BLVD, NEW ALBANY, IN 47150
 PHONE: 812-944-6733 FAX: 812-948-5047
 e-Mail: info@SAMTEC.com code: 55322

DO NOT SCALE DRAWING

SHEET SCALE: 2:1

DESCRIPTION:
 BNC7T EDGE MOUNT STRAIGHT JACK

DWG. NO.
 BNC7T-J-P-XX-ST-EM1

BY: G.HERMAN 01/04/2008 SHEET 2 OF 2

SAMTEC PART NUMBER	ITEM
SUB-BNC7T-J-P-XX-ST-EM1	SUB ASSEMBLY