



Chipsmall Limited consists of a professional team with an average of over 10 year of expertise in the distribution of electronic components. Based in Hongkong, we have already established firm and mutual-benefit business relationships with customers from,Europe,America and south Asia,supplying obsolete and hard-to-find components to meet their specific needs.

With the principle of “Quality Parts,Customers Priority,Honest Operation,and Considerate Service”,our business mainly focus on the distribution of electronic components. Line cards we deal with include Microchip,ALPS,ROHM,Xilinx,Pulse,ON,Everlight and Freescale. Main products comprise IC,Modules,Potentiometer,IC Socket,Relay,Connector.Our parts cover such applications as commercial,industrial, and automotives areas.

We are looking forward to setting up business relationship with you and hope to provide you with the best service and solution. Let us make a better world for our industry!



## Contact us

Tel: +86-755-8981 8866 Fax: +86-755-8427 6832

Email & Skype: info@chipsmall.com Web: www.chipsmall.com

Address: A1208, Overseas Decoration Building, #122 Zhenhua RD., Futian, Shenzhen, China





BP1277

## Installation Instructions

### DESCRIPTION

The BP1277 is a permanently connected, outlet box mounted, combination universal power supply (120-277VAC) and switching relay. The device is electrically connected to a Class 2, OMNI® series occupancy sensor and the two devices are twist locked together to form an integral line voltage occupancy sensor. The BP1277 provides a 24VDC, Class 2 supply for the sensor and controls power to the light load in response to the sensor's occupancy signal.

### PRECAUTIONS

**CAUTION: RISK OF ELECTRICAL SHOCK. Turn power off at service panel before beginning installation. Never wire energized electrical components. More than one disconnect switch may be required to de-energize the equipment before servicing.**

Read and understand all instructions before beginning installation.

**NOTICE:** For installation by a licensed electrician in accordance to national and/ or local electrical codes and the following instructions.

**NOTICE:** For indoor use only.

**CAUTION: USE COPPER CONDUCTORS ONLY**

Confirm that the device ratings are suitable for application prior to installation.

**NOTICE:** Do not install if any damage to the product is noticed.

### INSTALLATION

1. Turn power off at the service panel.
2. If power pack is shipped with sensor, disconnect sensor from power pack by rotating the sensor until it unlocks, then disconnecting the Quick-to-Install (QTI) connectors.
3. Electrically connect the power pack to the building and load wiring as shown in the wiring diagram. Use approved wire nuts for all electrical connections (Figure 1).
4. Mount power pack in single gang mud ring secured to a four inch square electrical box (Figure 2). Use screws (not included) as appropriate to application.

**NOTE: The OmniBP will fit on the following boxes or adapters:**

**A round 1 gang mud ring with 2-3/4" OC mounting holes. (RACO # 756-759, 767 or similar).**

**A 4" octagon box (RACO #125 or similar).**

5. Connect sensor to power pack using QTI connector.
6. Tuck QTI connector into pocket of power pack cover plate.
7. Twist sensor on to power pack mounting plate until secured (Figure 3).
8. Restore power at the service panel.

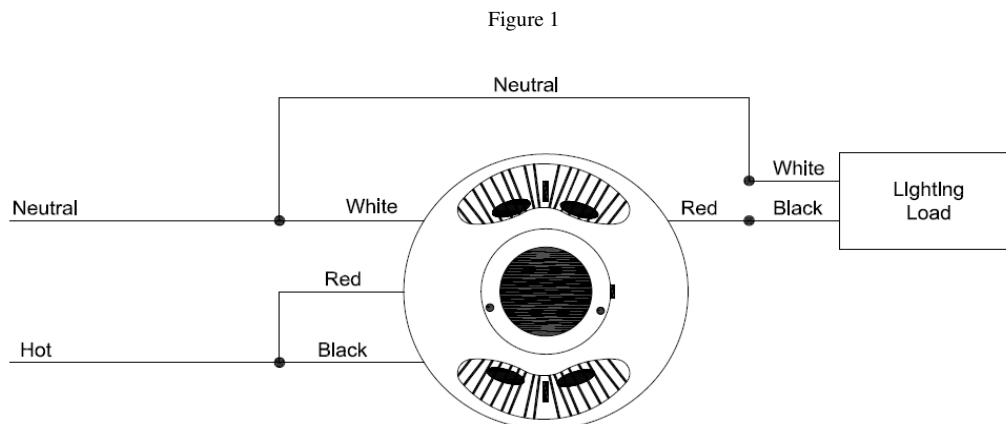

Figure 2

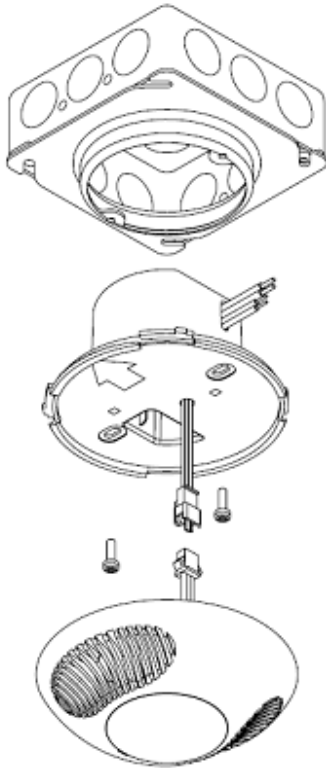

Figure 3

