



Chipsmall Limited consists of a professional team with an average of over 10 year of expertise in the distribution of electronic components. Based in Hongkong, we have already established firm and mutual-benefit business relationships with customers from,Europe,America and south Asia,supplying obsolete and hard-to-find components to meet their specific needs.

With the principle of “Quality Parts,Customers Priority,Honest Operation,and Considerate Service”,our business mainly focus on the distribution of electronic components. Line cards we deal with include Microchip,ALPS,ROHM,Xilinx,Pulse,ON,Everlight and Freescale. Main products comprise IC,Modules,Potentiometer,IC Socket,Relay,Connector.Our parts cover such applications as commercial,industrial, and automotives areas.

We are looking forward to setting up business relationship with you and hope to provide you with the best service and solution. Let us make a better world for our industry!



## Contact us

Tel: +86-755-8981 8866 Fax: +86-755-8427 6832

Email & Skype: info@chipsmall.com Web: www.chipsmall.com

Address: A1208, Overseas Decoration Building, #122 Zhenhua RD., Futian, Shenzhen, China



# Wireless LAN Module with Flash Memory

**BP3599**



## Enable wireless LAN communication by simply connecting to existing sets

### Product Outline

The BP3599 takes the IEEE802.11b/g/n BP3591 wireless LAN module with built-in antenna and flash memory. In addition, the antenna design is identical to the BP3591, eliminating the need for high-frequency circuitry, and the BP3599 is pin-compatible with the BP3591, making replacement easy. The internal flash memory comes pre-loaded with firmware including TCP/IP stack, and the module is already certified\* for use in Japan and the US, enabling implementation possible.

\*Please inquire regarding applicable radio laws in other countries

## All-in-one wireless LAN module

**Front**      **Rear**

- Built-in antenna eliminates the need for high-frequency designs
- Connect an external antenna via coaxial connector
- Integrated flash memory includes firmware
- MAC address information contained in the macro QR code
- Complies with applicable radio laws in Japan and the US
- MAC address included before shipment
- M2 screw holes for mounting
- 33.1mm height
- 0.5mm-pitch 34pin low profile connector
- 24mm width

Firmware, including the TCP/IP stack, is pre-loaded in the internal flash memory. Stations and access points are written in Regions 1 and 2, respectively, making it easy to change operating modes by switching the FLASH\_SEL pin from High to Low and vice versa.

## Specifications

Wireless LAN Standards	IEEE802.11b, IEEE802.11g IEEE802.11n, IEEE802.11i
Host Interface	UART (~921600bps)
Integrated Flash Memory	4Mbit serial flash memory
Transmission Frequency	2,400MHz to 2,483.5MHz (ch1-ch13)
Transmission Power	IEEE802.11b : 15dBm±2dB
	IEEE802.11g : 13dBm±2dB
	IEEE802.11n : 12dBm±2dB
Communication Rate	IEEE802.11b : 1-11Mbps
	IEEE802.11g : 6-54Mbps
	IEEE802.11n : 6.5-72.2Mbps
Access Method	CSMA/CA
Access Mode	Infrastructure/Ad hoc
Security	64bit/128bit WEP, TKIP, AES
Supply Voltage	3.3V
Current Consumption	Continuous transmission : 300mA typ.
	Reception : 200mA Typ.
	Sleep : 500µA
Operating Environment	Temperature : -40 to +85°C
	Humidity : <85% (No condensation)
WPS (Wi-Fi Protected Setup)	PIN/PBC methods
Radio Act Certification	Japan and the US (Japan only when using external antenna)

## Firmware with TCP/IP stack

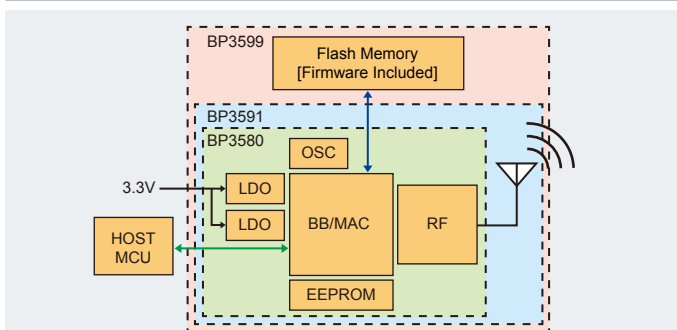

The firmware written in the flash memory includes protocols essential for wireless LAN communication, such as WPA-PSK, WPA2-PSK, and WPS. In addition, the pre-loaded TCP/IP stack enables both wireless LAN and network processing, making it easy to add IP communication to sets that previously could not support wireless LAN due to insufficient microcontroller processing capability or other restrictions.

### Configuration Options

A dedicated 2.54mm-pitch conversion board is available, while adding an optional external antenna improves communication distance and enables mounting in sets with metallic housings for broader applicability.

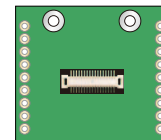

Dedicated Conversion Board      External Antenna

### Applications

- Industrial equipment, sensor networks, home networks
- Wireless LAN routers and peripheral devices
- Smartphones and the like
- Systems that could not support wireless LAN due to insufficient MCU
- Systems that could not support wireless LAN due to costs

**Support:** [http://micro.rohm.com/en/download\\_support/wireless\\_lan\\_system/](http://micro.rohm.com/en/download_support/wireless_lan_system/)