



Chipsmall Limited consists of a professional team with an average of over 10 year of expertise in the distribution of electronic components. Based in Hongkong, we have already established firm and mutual-benefit business relationships with customers from,Europe,America and south Asia,supplying obsolete and hard-to-find components to meet their specific needs.

With the principle of "Quality Parts,Customers Priority,Honest Operation,and Considerate Service",our business mainly focus on the distribution of electronic components. Line cards we deal with include Microchip,ALPS,ROHM,Xilinx,Pulse,ON,Everlight and Freescale. Main products comprise IC,Modules,Potentiometer,IC Socket,Relay,Connector.Our parts cover such applications as commercial,industrial, and automotives areas.

We are looking forward to setting up business relationship with you and hope to provide you with the best service and solution. Let us make a better world for our industry!



Contact us

Tel: +86-755-8981 8866 Fax: +86-755-8427 6832

Email & Skype: info@chipsmall.com Web: www.chipsmall.com

Address: A1208, Overseas Decoration Building, #122 Zhenhua RD., Futian, Shenzhen, China



DC/DC converter

BP5250/BP5250-24

The BP5250/BP5250-24 are DC/DC converters for step-down that can drive PchFET using PWM system. The voltage setting resistor and the combination of external power elements enable you to make any power circuit to your liking. High-efficient DC/DC converter can be made easy by adding external components such as I/O smoothing capacitor without designing circuit.

● Applications

OA appliances(copy machine, personal computer, facsimile), AV appliances (car navigation, DVD etc.), and industrial appliances.

● Features

- 1) High power conversion($\eta=90\%$ $V_{in}=12V$ 5V/2A)
- 2) Power save pin(Leakage current at OFF mode : $I_R=10\mu A_{MAX}$)
- 3) Output voltage can be established from 1.5V to 9V in the VADJ pin.(For BP5250, however, output voltage is limited by input voltage.)
- 4) With recovery type overcurrent protection function (Detection current can be established by the external current detection resistance.)
- 5) Power circuit can be made easy by adding external smoothing capacitor and power element.
- 6) Reference voltage accuracy $1.25V\pm 1\%$

● Absolute maximum ratings ($T_a=25^\circ C$)

Parameter	Symbol	Limits		Unit	Condition
		BP5250	BP5250-24		
Input voltage	V_i	24	30	V	DC
ESD endurance	V_{surge}	1		kV	(EIAJ ED4701-1C-111A)
Operating temperature range	T_{opr}	-40 ~ +85		$^\circ C$	
Storage temperature range	T_{stg}	-50 ~ +100		$^\circ C$	
Allowable max surface temperature	T_{fmax}	100		$^\circ C$	Ambient temperature+The module self-heating $\leq T_{fmax}$
The power saving terminal voltage	V_{CTL}	24	30	V	$V_i \geq V_{CTL}$

● Recommended operating conditions ($T_a=25^\circ C$)

Parameter		Symbol	Min.	Typ.	Max.	Unit
Input voltage	BP5250	V_i	8	12	16	V
	BP5250-24		20	24	27	V

● Block diagram

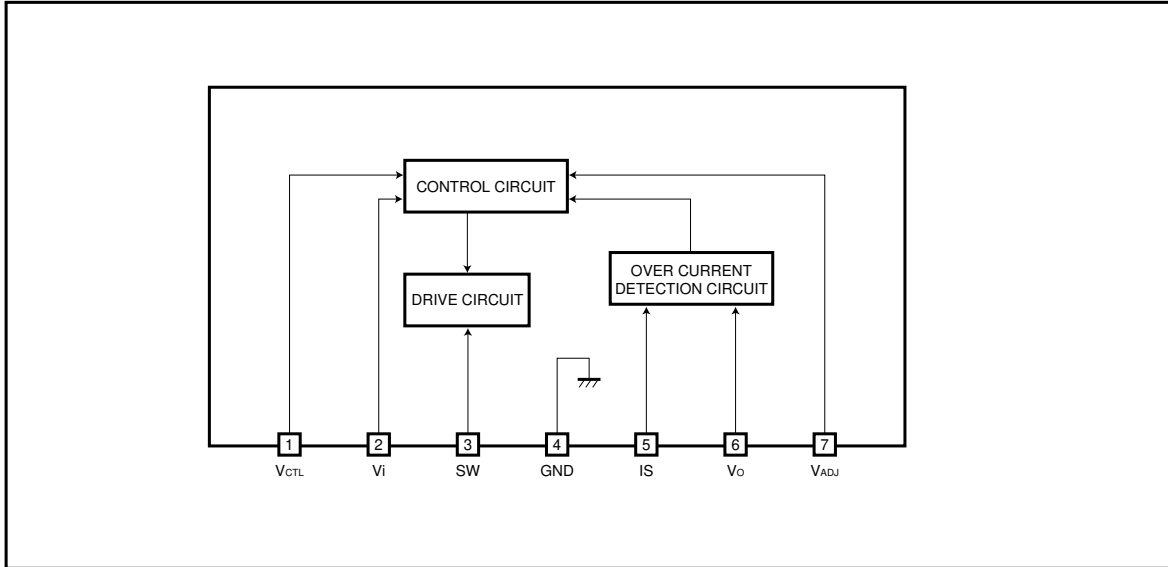

● Pin descriptions

Pin No.	Pin name	Function
1	V _{CTL}	Power save terminal. Setting the voltage on this terminal to Low or high impedance turns the output OFF. Normally connect to V _i for use.
2	V _i	Input voltage terminal. Inserting a bypass capacitor of 0.1μF between this and pin 4 GND is recommended.
3	SW	Terminal to drive the external FET gate.
4	GND	GND terminal. Connect the negative terminal of the I/O smoothing capacitor and the anode terminal of the flywheel diode nearby.
5	IS	Overcurrent detection terminal. The value of the resistor inserted between this and pin 6 sets the output current capacity.
6	V _o	Output voltage monitor terminal.
7	V _{ADJ}	Output voltage setting terminal. The values of the resistors inserted between this and pin 6 and between this and GND set the output voltage capacity.

● **Electrical characteristics** (Unless otherwise noted, $V_i=12V$: BP5250, $V_i=24V$: BP5250-24, $T_a=25^\circ C$)

Parameter	Symbol	Min.	Typ.	Max.	Unit	Conditions	Test Circuit
Output ADJ Pin voltage	V_{ADJ}	1.225	1.25	1.275	V	VSW L→H	Fig.1
Over current detection off set voltage1	V_{LT1}	60	68	76	mV	VSW L→H $V_{ADJ}=1.25V$	Fig.2
Over current detection off set voltage2	V_{LT2}	20	28	36	mV	VSW L→H $V_{ADJ}=0V$	Fig.2
CTL pin ON voltage	V_{CTLH}	2	-	-	V	VSW H→L	Fig.3
CTL pin OFF voltage	V_{CTLL}	-	-	1	V	VSW L→H	Fig.3
CTL sink current	I_{CTL}	40	50	70	μA	$V_{CTL}=5V$	Fig.3
Stand by current	I_{STB}	-	0	10	μA	$V_{CTL}=0V$	Fig.3

● **Measurement circuit**

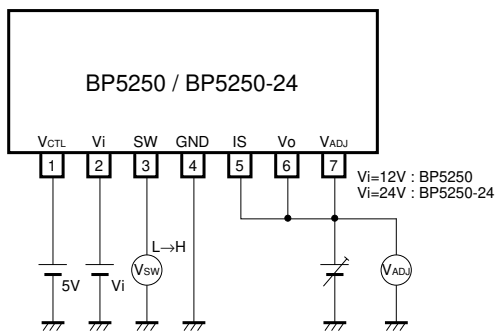
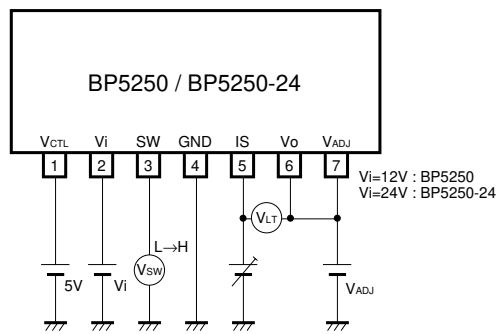
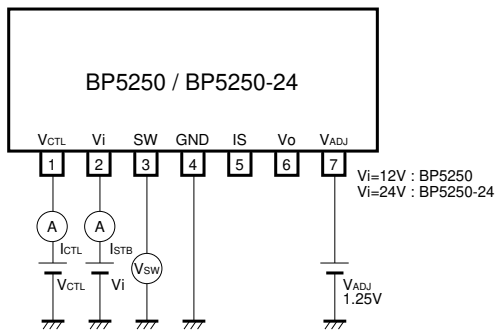

Fig.1 Output ADJ terminal voltage measurement circuit



Over current detection off set voltage 1 : $V_{ADJ}=1.25V$
 Over current detection off set voltage 2 : $V_{ADJ}=0V$

Fig.2 Over current detection off set voltage measurement circuit



CTL sink current : $V_{CTL}=5V$
 Stand by current : $V_{CTL}=0V$

Fig.3 Control terminal voltage sink current - Stand by sink current measurement circuit

● Application example

(1) Application circuit example is shown in the Fig.4.

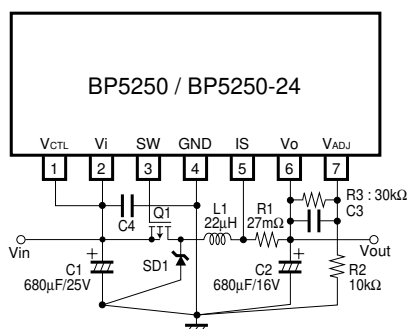

Fig.4

*Application

- Input voltage 12V
- Output current 2A
- Output voltage 5V
- Q1 : 2SJ529S/Hitachi
- SD : RB050L-40/ROHM
- L1 : CDRH124-220L/Sumida
- C1 : 680µF/25V(ZL series)/Rubycon
- C2 : 680µF/10V(ZL series)/Rubycon
- C3 : 0.1µF/16V
- C4 : 0.1µF/25V

- There is a possibility that the C1 exceeds the allowable ripple current. Note the allowable ripple current of the capacitor to be used.
- $R2+R3 \leq 55K\Omega$ is recommended for R2,3 to make the most of output voltage accuracy.
- Output voltage range is limited by input voltage. Please refer to the Fig.8.

R1 : Over-current detection resistance $R1=0.068V/(0.068V : \text{offset voltage})$
 Overcurrent protection characteristic at $R1=27m\Omega$ is shown below.

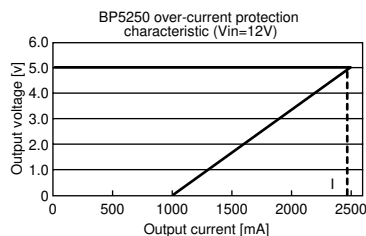

R2, R3 : Output voltage establishment resistance

$V_o = V_{ADJ} \times (1 + R3/R2)$
 $(R2 + R3 \leq 55k\Omega)$

Establishment example			
	Vo(V)	R2(Ω)	R3(Ω)
	8.0	3.3k	18k
	5.0	10k	30k
	3.3	20k	33k
	2.5	10k	10k
	1.5	10k	2k

(2) When the load current is increased.

It is possible by arrangement in a parallel connecting Q1, 2 and SD1,2

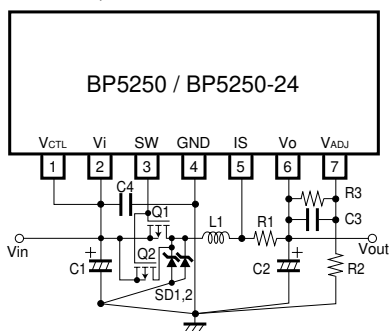

Fig.5

- When Q1 and Q2 are connected parallel, use of a device with small gate capacity is recommended. Large gate capacity reduces the switching speed, which may cause a larger FET loss, exceeding the allowable loss value.
- When 2SJ529S is connected parallel, the rated load current 3A is the maximum at $V_i=12V, V_o=5V$

(3) When the power saving function is used.

The output is off when the VCTL pin is set to the Low or high-impedance.

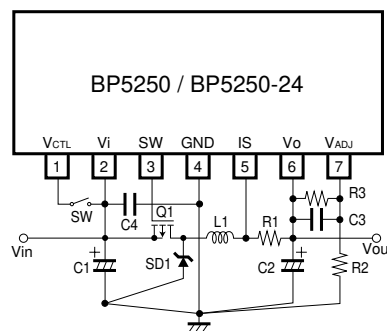

Fig.6

● Output voltage establishment range

Output voltage establishment range is changed by input voltage. Please refer to the Fig.8.

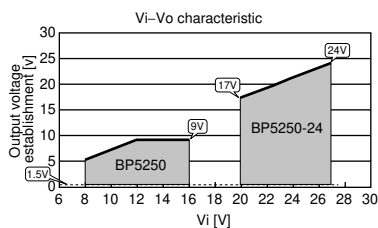

Fig.8

● Caution note for operation

- (1) Output voltage establishment range is changed by input voltage. Please refer to the Fig.8.
- (2) Layout of external parts may significantly change the output spike noise or characteristics or cause abnormal oscillation and temperature increase. Note the following for layout.
 - Provide the input smoothing electrolytic capacitor close to the FET source and pin 2 of the module.
 - Provide the output smoothing electrolytic capacitor close to pin 6 of the module together with the current detection resistor
 - Large current may run into the coil, current detection resistor and output through the FET source-drain. Try to use a solid pattern as much as possible.
 - FET drain, coil and flywheel diode may generate heat by power loss. Try to use a solid pattern so that the heat may be released. Measure a rise in temperature of each element and make sure that it is not abnormal.
 - Provide the negative terminal of the I/O smoothing capacitor and anode terminal of the flywheel diode close to GND pin 4 of the module.
 - Connect the negative terminal of the I/O smoothing electrolytic capacitor and anode terminal of the flywheel diode nearby.
- (3) Output load may cause large ripple current in the I/O smoothing electrolytic capacitor. Note the allowable ripple current of the capacitor to be used.
- (4) As the output smoothing electrolytic capacitor, one with especially low impedance is recommended for suppressing output ripple voltage. Select a capacitor suited for the use.
- (5) Please be sure to use protection circuit function. (R1 should not be 0Ω.)

● Output voltage establishment and application circuit example

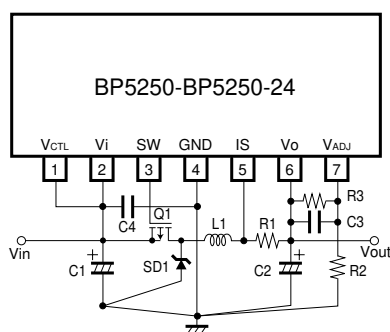

Fig.9

*Application example

Input voltage 12V

Output voltage 5V

Q1 : 2SJ529S/hitachi

SD : RB050L-40/ROHM

L1 : CDRH124-220L/Sumida

C1 : 680μF/25V(ZL series)/Rubycon

C2 : 680μF/16V(ZL series)/Rubycon

C3 : 0.1μF/16V/ROHM

C4 : 0.1μF/25V/ROHM

R1 : 27mΩ/SUSUMU

R2 : 10kΩ/ROHM

R3 : 30kΩ/ROHM

(1) Output voltage and resistance

Output voltage V_o is determined by output ADJ pin voltage(V_{ADJ}) and R_2 , R_3 .

$$V_o = V_{ADJ} \times (1 + R_3/R_2) [V] \quad V_{ADJ} = 1.25V$$

Note) Please set the resistance to $R_2 + R_3 \leq 55K\Omega$ to make the best use of this module performance.

Establishment example		
$V_o(V)$	$R_2(\Omega)$	$R_3(\Omega)$
8.0	3.3k	18k
5.0	10k	30k
3.3	20k	33k
2.5	10k	10k
1.5	10k	2k

(2) FET(Q1)

FET is determined by taking the peak current flowed to the external FET, drain-source voltage(V_{DS}), ON resistance($R_{DS(ON)}$), input capacity(C_{iss}), allowable loss of package, and area of safe operation.

For the basic circuit example(Fig.9), FET of 2SJ529S/Hitachi is used.

Please use FET with the characteristic equal to or than this one. Especially, the input capacity(C_{iss}), and ON resistance may cause a larger FET loss. Note the FET with the characteristic equal to or higher to be used.

The characteristic of 2SJ529S is

$V_{DS} = -60V$
 $I_D = -10A$
 $R_{DS(ON)} = 0.17\Omega$ TYP ($I_D = -5A$, $V_{DS} = -4V$)
 $P_{ch} = 20W$ ($T_c = 25^\circ C$)
 $C_{iss} = 580PF$

(3) Inductor(L1)

inductor L1 is determined by the following expression in consideration of output ripple current.

$$L1 \geq n \times (V_i - V_o) / I_o \times 1/f \times V_o / V_i [H]$$

V_i : Input voltage [V]
 V_o : Output voltage [V]
 I_o : Output current [A]
 f : Oscillation frequency ($\approx 190KHz$)
 n : Ripple current condition
 I_o/n is ripple current. Normally, $n=2.5\sim 5$ is recommended.

L is determined from above.

Peak current flowed into the inductor by the determined L is

$$I_p = I_o + (V_i - V_o) / 2 \times 1/L1 \times 1/f \times (1 - V_o/V_i) [A]$$

I_p for actual usage is calculated back by the L of the expression above.

Ripple current I_r by the determined L is

$$I_r = (V_i - V_o) / L1 \times 1/f \times V_o / V_i [A]$$

As stated above, after $L1[H]$ inductor and the $I_p[A]$ peak current are determined, an inductor for these specifications can be determined. Output ripple voltage is determined by the multiplication of the $I_r[A]$ ripple current and the impedance of the smoothing capacitor.

$$V_r = I_r \times Z_c$$

V_r : Output ripple voltage [Vp-p]

Z_c : Impedance of smoothing capacitor [Ω]

(4) Flywheel diode(SD1)

- Rated current must be twice as much as the maximum overload current(Iomax) or more.
- Rated voltage must be 1.3 times as much as the maximum input voltage or more.
- Please use the high-speed switching schottky barrier diode that reverse recovery time is 50ns or less.
- If it used in high temperature, please be careful about the temperature characteristics of IR.

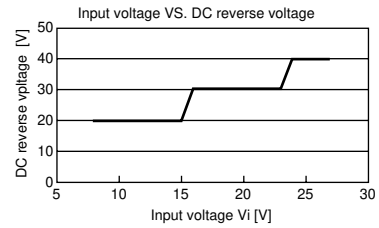

(5) Overcurrent detection resistor(R1)

Overcurrent detection resistor is determined by the following expression.

$$R1 = VLT1 / I_{omax} \text{ [m}\Omega\text{]}$$

VLT1 : Overcurrent offset voltage1(60~76mV)

Iomax : Maximum overload current [A]

And, ISL current at short circuit is

$$ISL = VLT2 / R1 \text{ [A]}$$

VLT2 : Overcurrent detection offset voltage2(20~36mV)

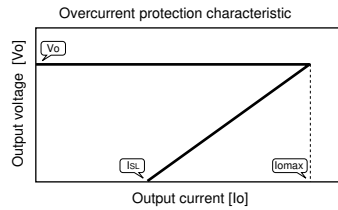

From the above-mentioned, fold-back current characteristic when the overcurrent protection is operated is shown. Both Iomax, and ISL may be different value from the actual value because they are detected at the peak current. Please make sure to confirm it in the actual operating.

(6) Input smoothing capacitor(C1)

Large ripple current flow into the input smoothing capacitor. The current is determined by the following expression. For actual usage, please use the larger one than this numeric value.

$$I_{rms} = i_r \times \sqrt{V_o / 3V_i} + (i_p - i_r) \times \sqrt{V_o / V_i} \text{ [A]}$$

I_{rms} : Input ripple current actual-value [Arms]

i_r : Ripple current [A]

i_p : Peak current [A]

V : Input voltage [V]

V_o : Output voltage [V]

- Voltage of the used capacitor must be more than V_i × 2.
- Allowable ripple current of the used capacitor must be larger than the ripple current.

(7) Output smoothing capacitor(C2)

Output smoothing capacitor is determined by the impedance of smoothing capacitor from the mark value of output ripple voltage.

$$Z_c \leq V_r / i_r \text{ [}\Omega\text{]}$$

Z_c : Impedance of capacitor [Ω]

V_r : Mark value of output ripple voltage[V_{p-p}]

i_r : Ripple current [A]

- Voltage of the used capacitor must be more than V_o × 2.
- Allowable ripple current of the used capacitor must be larger than the ripple current.

● External dimensions (Units : mm)

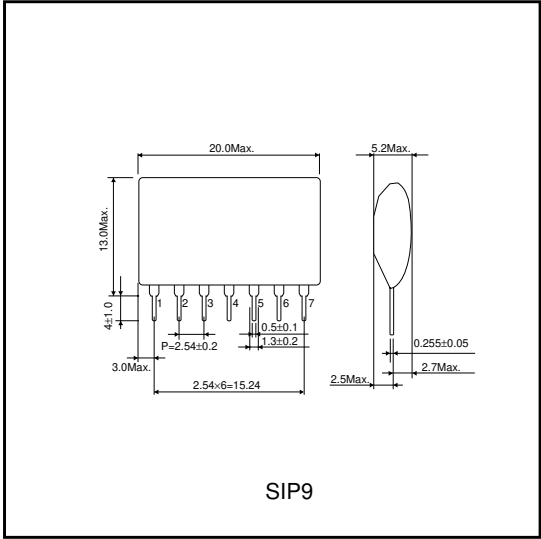

● BP5250 external reference components

Input voltage 12V

Output current	1A					Note
output voltage	1.5V±3%	2.5V±3%	3.3V±3%	5V±3%	8V±3%	
Q 1	CPH6306	CPH6306	CPH6306	CPH6306	CPH6306	
SD1	RB050L-40	RB050L-40	RB050L-40	RB050L-40	RB050L-40	
L1	17~34μH±10%	26~52μH±10%	31~63μH±10%	38~77μH±10%	35~70μH±10%	Rated current
	1.3A or higher	1.3A or higher	1.3A or higher	1.4A or higher	1.5A or higher	
C1	0.4Arms or higher	0.5Arms or higher	0.6Arms or higher	0.7Arms or higher	0.9Arms or higher	Allowable ripple currnt
	220~4700μF	220~4700μF	220~4700μF	220~4700μF	330~4700μF	
C2	0.3Arms or higher	0.3Arms or higher	0.3Arms or higher	0.3Arms or higher	0.3Arms or higher	Allowable ripple currnt
	220~1000μF	220~1000μF	220~1000μF	220~1000μF	220~1000μF	
C3	0.1μF/16V (R)	0.1μF/16V (R)	0.1μF/16V (R)	0.1μF/16V (R)	0.1μF/16V (R)	
C4	0.1μF/25V (R)	0.1μF/25V (R)	0.1μF/25V (R)	0.1μF/25V (R)	0.1μF/25V (R)	
R1	56mΩ±5% less than	56mΩ±5% less than	56mΩ±5% less than	56mΩ±5% less than	56mΩ±5% less than	
R2	10kΩ±1%	10kΩ±1%	20kΩ±1%	10kΩ±1%	3.3kΩ±1%	
R3	2kΩ±1%	10kΩ±1%	33kΩ±1%	30kΩ±1%	18kΩ±1%	

Output current	2A					Note
output voltage	1.5V±3%	2.5V±3%	3.3V±3%	5V±3%	8V±3%	
Q 1	2SJ529S	2SJ529S	2SJ529S	2SJ529S	2SJ529S	
SD1	RB050L-40	RB050L-40	RB050L-40	RB050L-40	RB050L-40	
L1	9~17μH±10%	13~26μH±10%	16~31μH±10%	19~38μH±10%	17~35μH±10%	Rated current
	2.5A or higher	2.5A or higher	2.5A or higher	2.5A or higher	2.6A or higher	
C1	0.8Arms or higher	1Arms or higher	1Arms or higher	1.5Arms or higher	1.8Arms or higher	Allowable ripple currnt
	330~4700μF	330~4700μF	330~4700μF	680~4700μF	680~4700μF	
C2	0.6Arms or higher	0.6Arms or higher	0.6Arms or higher	0.6Arms or higher	0.7Arms or higher	
	560~1500μF	560~1500μF	560~1500μF	560~1500μF	560~1500μF	
C3	0.1μF/16V (R)	0.1μF/16V (R)	0.1μF/16V (R)	0.1μF/16V (R)	0.1μF/16V (R)	
C4	0.1μF/25V (R)	0.1μF/25V (R)	0.1μF/25V (R)	0.1μF/25V (R)	0.1μF/25V (R)	
R1	27mΩ±5% less than	27mΩ±5% less than	27mΩ±5% less than	27mΩ±5% less than	27mΩ±5% less than	
R2	10kΩ±1%	10kΩ±1%	20kΩ±1%	10kΩ±1%	3.3kΩ±1%	
R3	2kΩ±1%	10kΩ±1%	33kΩ±1%	30kΩ±1%	18kΩ±1%	

Output current	3A					Note
output voltage	1.5V±3%	2.5V±3%	3.3V±3%	5V±3%	8V±3%	
Q 1	2SJ529S×2	2SJ529S×2	2SJ529S×2	2SJ529S×2	2SJ529S×2	
SD1	RB050L-40×2	RB050L-40×2	RB050L-40×2	RB050L-40×2	RB050L-40×2	
L1	6~11μH±10%	9~17μH±10%	10~21μH±10%	13~26μH±10%	12~23μH±10%	Rated current
	3.7A or higher	3.7A or higher	3.8A or higher	3.8A or higher	3.9A or higher	
C1	1.2Arms or higher	1.5Arms or higher	1.8Arms or higher	2.2Arms or higher	2.7Arms or higher	Allowable ripple currnt
	470~4700μF	680~4700μF	680~4700μF	1000~4700μF	1500~4700μF	
C2	0.8Arms or higher	0.9Arms or higher	0.9Arms or higher	0.9Arms or higher	1Arms or higher	
	680~1500μF	680~1500μF	680~1500μF	680~1500μF	680~1500μF	
C3	0.1μF/16V (R)	0.1μF/16V (R)	0.1μF/16V (R)	0.1μF/16V (R)	0.1μF/16V (R)	
C4	0.1μF/25V (R)	0.1μF/25V (R)	0.1μF/25V (R)	0.1μF/25V (R)	0.1μF/25V (R)	
R1	18mΩ±5% less than	18mΩ±5% less than	18mΩ±5% less than	18mΩ±5% less than	18mΩ±5% less than	
R2	10kΩ±1%	10kΩ±1%	20kΩ±1%	10kΩ±1%	3.3kΩ±1%	
R3	2kΩ±1%	10kΩ±1%	33kΩ±1%	30kΩ±1%	18kΩ±1%	

● BP5250-24 external referene components

Input voltage 24V

Output current	1A					Note
Output voltage	1.5V±3%	2.5V±3%	3.3V±3%	5V±3%	8V±3%	
Q 1	CPH6306	CPH6306	CPH6306	CPH6306	CPH6306	
SD1	RB050L-40	RB050L-40	RB050L-40	RB050L-40	RB050L-40	
L1	18~37μH±10%	30~59μH±10%	37~75μH±10%	52~105μH±10%	70~140μH±10%	
	1.3A or higher	1.3A or higher	1.3A or higher	1.3A or higher	1.3A or higher	Rated current
C1	0.3Arms or higher	0.4Arms or higher	0.4Arms or higher	0.5Arms or higher	0.7Arms or higher	Allowable ripple current
	33~4700μF	100~4700μF	100~4700μF	100~4700μF	100~4700μF	
C2	0.3Arms or higher	0.3Arms or higher	0.3Arms or higher	0.3Arms or higher	0.3Arms or higher	Allowable ripple current
	220~1000μF	220~1000μF	220~1000μF	220~1000μF	220~1000μF	
C3	0.1μF/16V (R)	0.1μF/16V (R)	0.1μF/16V (R)	0.1μF/16V (R)	0.1μF/16V (R)	
C4	0.1μF/50V (R)	0.1μF/50V (R)	0.1μF/50V (R)	0.1μF/50V (R)	0.1μF/50V (R)	
R1	56mΩ±5% less than	56mΩ±5% less than	56mΩ±5% less than	56mΩ±5% less than	56mΩ±5% less than	
R2	10kΩ±1%	10kΩ±1%	20kΩ±1%	10kΩ±1%	3.3kΩ±1%	
R3	2kΩ±1%	10kΩ±1%	33kΩ±1%	30kΩ±1%	18kΩ±1%	

Output current	2A					Note
Output voltage	1.5V±3%	2.5V±3%	3.3V±3%	5V±3%	8V±3%	
Q 1	2SJ529S	2SJ529S	2SJ529S	2SJ529S	2SJ529S	
SD1	RB050L-40	RB050L-40	RB050L-40	RB050L-40	RB050L-40	
L1	9~18μH±10%	15~30μH±10%	19~38μH±10%	26~52μH±10%	35~70μH±10%	
	2.5A or higher	2.5A or higher	2.5A or higher	2.5A or higher	2.5A or higher	Rated current
C1	0.6Arms or higher	0.7Arms or higher	0.8Arms or higher	1Arms or higher	1.3Arms or higher	Allowable ripple current
	100~4700μF	100~4700μF	220~4700μF	220~4700μF	220~4700μF	
C2	0.6Arms or higher	0.6Arms or higher	0.6Arms or higher	0.6Arms or higher	0.6Arms or higher	Allowable ripple current
	560~1500μF	560~1500μF	560~1500μF	560~1500μF	560~1500μF	
C3	0.1μF/16V (R)	0.1μF/16V (R)	0.1μF/16V (R)	0.1μF/16V (R)	0.1μF/16V (R)	
C4	0.1μF/50V (R)	0.1μF/50V (R)	0.1μF/50V (R)	0.1μF/50V (R)	0.1μF/50V (R)	
R1	27mΩ±5% less than	27mΩ±5% less than	27mΩ±5% less than	27mΩ±5% less than	27mΩ±5% less than	
R2	10kΩ±1%	10kΩ±1%	20kΩ±1%	10kΩ±1%	3.3kΩ±1%	
R3	2kΩ±1%	10kΩ±1%	33kΩ±1%	30kΩ±1%	18kΩ±1%	

Output current	3A					Note
Output voltage	1.5V±3%	2.5V±3%	3.3V±3%	5V±3%	8V±3%	
Q 1	2SJ529S×2	2SJ529S×2	2SJ529S×2	2SJ529S×2	2SJ529S×2	
SD1	RB050L-40×2	RB050L-40×2	RB050L-40×2	RB050L-40×2	RB050L-40×2	
L1	6~12μH±10%	10~20μH±10%	13~25μH±10%	17~35μH±10%	23~47μH±10%	
	3.8A or higher	3.8A or higher	3.8A or higher	3.8A or higher	3.8A or higher	Rated current
C1	0.9Arms or higher	1Arms or higher	1.2Arms or higher	1.5Arms or higher	1.9Arms or higher	Allowable ripple current
	220~4700μF	220~4700μF	220~4700μF	470~4700μF	470~4700μF	
C2	0.9Arms or higher	0.9Arms or higher	0.9Arms or higher	0.9Arms or higher	0.9Arms or higher	Allowable ripple current
	680~1500μF	680~1500μF	680~1500μF	680~1500μF	680~1500μF	
C3	0.1μF/16V (R)	0.1μF/16V (R)	0.1μF/16V (R)	0.1μF/16V (R)	0.1μF/16V (R)	
C4	0.1μF/25V (R)	0.1μF/25V (R)	0.1μF/25V (R)	0.1μF/25V (R)	0.1μF/25V (R)	
R1	18mΩ±5% less than	18mΩ±5% less than	18mΩ±5% less than	18mΩ±5% less than	18mΩ±5% less than	
R2	10kΩ±1%	10kΩ±1%	20kΩ±1%	10kΩ±1%	3.3kΩ±1%	
R3	2kΩ±1%	10kΩ±1%	33kΩ±1%	30kΩ±1%	18kΩ±1%	

Precautions on Use of ROHM Power Module

Safety Precautions

- 1) The products are designed and produced for application in ordinary electronic equipment (AV equipment, OA equipment, telecommunication equipment, home appliances, amusement equipment etc.).
If the products are to be used in devices requiring extremely high reliability (medical equipment, transport equipment, aircraft/spacecraft, nuclear power controllers, fuel controllers, car equipment including car accessories, safety devices, etc.) and whose malfunction or operational error may endanger human life and sufficient fail-safe measures, please consult with the Company's sales staff in advance. If product malfunctions may result in serious damage, including that to human life, sufficient fail-safe measures must be taken, including the following:
 - [a] Installation of protection circuits or other protective devices to improve system safety
 - [b] Installation of redundant circuits in the case of single-circuit failure
- 2) The products are designed for use in a standard environment and not in any special environments. Application of the products in a special environment can deteriorate product performance. Accordingly, verification and confirmation of product performance, prior to use, is recommended if used under the following conditions:
 - [a] Use in various types of liquid, including water, oils, chemicals, and organic solvents
 - [b] Use outdoors where the products are exposed to direct sunlight, or in dusty places
 - [c] Use in places where the products are exposed to sea winds or corrosive gases, including Cl₂, H₂S, NH₃, SO₂, and NO₂
 - [d] Use in places where the products are exposed to static electricity or electromagnetic waves
 - [e] Use in proximity to heat-producing components, plastic cords, or other flammable items
 - [f] Use involving sealing or coating the products with resin or other coating materials
 - [g] Use involving unclean solder or use of water or water-soluble cleaning agents for cleaning after soldering
 - [h] Use of the products in places subject to dew condensation
- 3) The products are not radiation resistant.
- 4) The Company is not responsible for any problems resulting from use of the products under conditions not recommended herein.
- 5) The Company should be notified of any product safety issues. Moreover, product safety issues should be periodically monitored by the customer.

Precautions Regarding Application Example and External Circuits

- 1) If change is made to the constant of an external circuit, allow a sufficient margin due to variations of the characteristics of the products and external components, including transient characteristics, as well as static characteristics. Please be informed that the Company has not conducted investigations on whether or not particular changes in the application examples or external circuits would result in the infringement of patent rights of a third party.
- 2) The application examples, their constants, and other types of information contained herein are applicable only when the products are used in accordance with standard methods.
Therefore, if mass production is intended, sufficient consideration to external conditions must be made.

Prohibitions Regarding Industrial Property

- 1) These Specifications contain information related to the Company's industrial property. Any use of them other than pertaining to the usage of appropriate products is not permitted. Duplication of these Specifications and its disclosure to a third party without the Company's permission is prohibited.
- 2) Information and data on products, including application examples, contained in these specifications are simply for reference; the Company does not guarantee any industrial property rights, intellectual property rights, or any other rights of a third party regarding this information or data. Accordingly, the Company does not bear any responsibility for:
 - [a] infringement of the intellectual property rights of a third party
 - [b] any problems incurred by the use of the products listed herein.
- 3) The Company prohibits the purchaser of its products to exercise or use the intellectual property rights, industrial property rights, or any other rights that either belong to or are controlled by the Company, other than the right to use, sell, or dispose of the products.