



Chipsmall Limited consists of a professional team with an average of over 10 year of expertise in the distribution of electronic components. Based in Hongkong, we have already established firm and mutual-benefit business relationships with customers from,Europe,America and south Asia,supplying obsolete and hard-to-find components to meet their specific needs.

With the principle of "Quality Parts,Customers Priority,Honest Operation,and Considerate Service",our business mainly focus on the distribution of electronic components. Line cards we deal with include Microchip,ALPS,ROHM,Xilinx,Pulse,ON,Everlight and Freescale. Main products comprise IC,Modules,Potentiometer,IC Socket,Relay,Connector.Our parts cover such applications as commercial,industrial, and automotives areas.

We are looking forward to setting up business relationship with you and hope to provide you with the best service and solution. Let us make a better world for our industry!



Contact us

Tel: +86-755-8981 8866 Fax: +86-755-8427 6832

Email & Skype: info@chipsmall.com Web: www.chipsmall.com

Address: A1208, Overseas Decoration Building, #122 Zhenhua RD., Futian, Shenzhen, China



SHARP

OPTO-ELECTRONIC DEVICES DIVISION
ELECTRONIC COMPONENTS GROUP
SHARP CORPORATION

SPECIFICATION

DEVICE SPECIFICATION FOR

Blue-sensitive photodiode

MODEL No.

BS120E0F

Specified for

Enclosed please find copies of the Specifications which consists of 8 pages including cover.
After confirmation of the contents, please be sure to send back copies of the Specifications
with approving signature on each.

CUSTOMER'S APPROVAL

DATE

BY

PRESENTED

DATE

BY

H. O
H. Ogura,
Department General Manager of
Engineering Dept., III
Opto-Electronic Devices Div.
ELECOM Group
SHARP CORPORATION

SHARP CORPORATION RECORDS OF REVISION	Model No.	BS120E0F
	FIRST ISSUE	April 28, 2005
	IDENT. DATA No.	ED-05G104

DATE	REF PAGE PARAGRAPH DRAWING No.	REVISED No.	SUMMARY	CHECK & APPROVAL
Apr 28, 2005			Establish	

Product name BLUE SENSITIVE PHOTODIODE

Model No. BS120E0F

1. These specification sheets include materials protected under copyright of Sharp Corporation ("Sharp"). Please do not reproduce or cause anyone to reproduce them without Sharp's consent.
2. When using this product, please observe the absolute maximum ratings and the instructions for use outlined in these specification sheets, as well as the precautions mentioned below. Sharp assumes no responsibility for any damage resulting from use of the product which does not comply with the absolute maximum ratings and the instructions included in these specification sheets, and the precautions mentioned below.

(Precautions)

- (1) This product is designed for use in the following application areas ;

(· OA equipment · Audio visual equipment · Home appliances
· Telecommunication equipment (Terminal) · Measuring equipment
· Tooling machines · Computers)

If the use of the product in the above application areas is for equipment listed in paragraphs (2) or (3), please be sure to observe the precautions given in those respective paragraphs.

- (2) Appropriate measures, such as fail-safe design and redundant design considering the safety design of the overall system and equipment, should be taken to ensure reliability and safety when this product is used for equipment which demands high reliability and safety in function and precision, such as ;

(· Transportation control and safety equipment (aircraft, train, automobile etc.)
· Traffic signals · Gas leakage sensor breakers · Rescue and security equipment
· Other safety equipment etc.)

- (3) Please do not use this product for equipment which require extremely high reliability and safety in function and precision, such as ;

(· Space equipment · Telecommunication equipment (for trunk lines)
· Nuclear power control equipment · Medical equipment etc.)

- (4) Please contact and consult with a Sharp sales representative if there are any questions regarding interpretation of the above three paragraphs.

3. Please contact and consult with a Sharp sales representative for any questions about this product.

1. Application

This specification applies to the outline and characteristics of Silicon photodiode Model No.BS120E0F.

2. Outline

Outline Dimensions: Refer to the attached drawing No. CY13053D02.

3. Ratings and characteristics

Refer to the attached sheet, page 4.

4. Reliability

Refer to the attached sheet, page 5.

5. Outgoing inspection

Refer to the attached sheet, page 6.

6. Supplement

6.1 This product is not designed as electromagnetic and ionized-particle radiation resistant.

6.2 This product shall not contain the following materials.

Also, the following materials shall not be used in the production process for this product.

Materials for ODS: CFCs, Halon, Carbon tetrachloride

1.1.1-Trichloroethane (Methyl chloroform)

6.3 Lead (Pb) is not used for this product.

6.4 Product mass (Piece): Approximately 120mg

7. Notes

7.1 Cleaning conditions:

Solvent cleaning: Solvent temperature 45°C or less Immersion for 30 s or less

Ultrasonic cleaning: The effect on the product depends on the size of cleaning tank, ultrasonic output, time, board size, mounting method of product.

Please certainly confirm that there is no defect under the actual conditions before the cleaning

The cleaning shall be carried out with solvent below.

Solvent: Ethyl alcohol, Methyl alcohol, Isopropyl alcohol

7.2

The lead pins should be soldered according to the item 3-1 absolute maximum ratings.

While or after soldering, the lead pins shall be free from external force.

This device shall not be soldered with preheat or reflow.

The lead-free solder is used for the leads' surface finishing.

Regarding the lead-free solder, the boundary separation between the solder and the land (lift-off) may be caused with depending on the kind of solder. Please certainly confirm that there is no defect under the actual conditions before the use.

SHARP

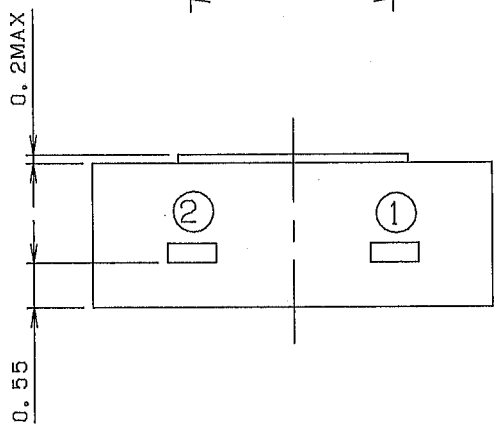
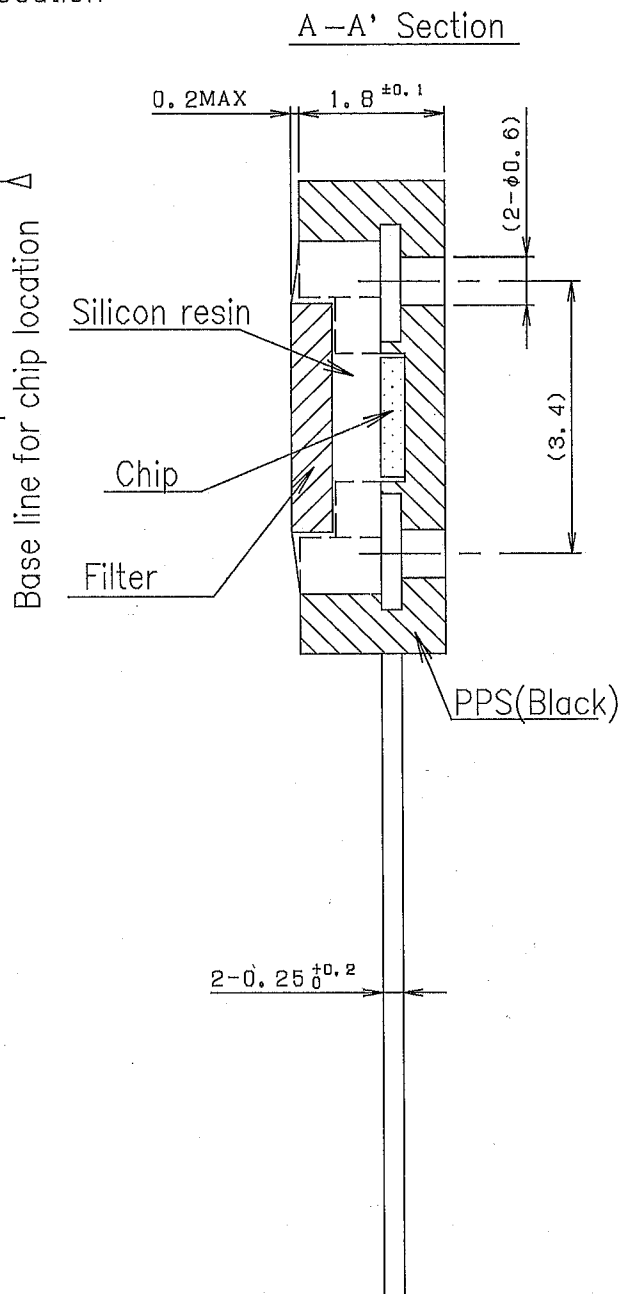
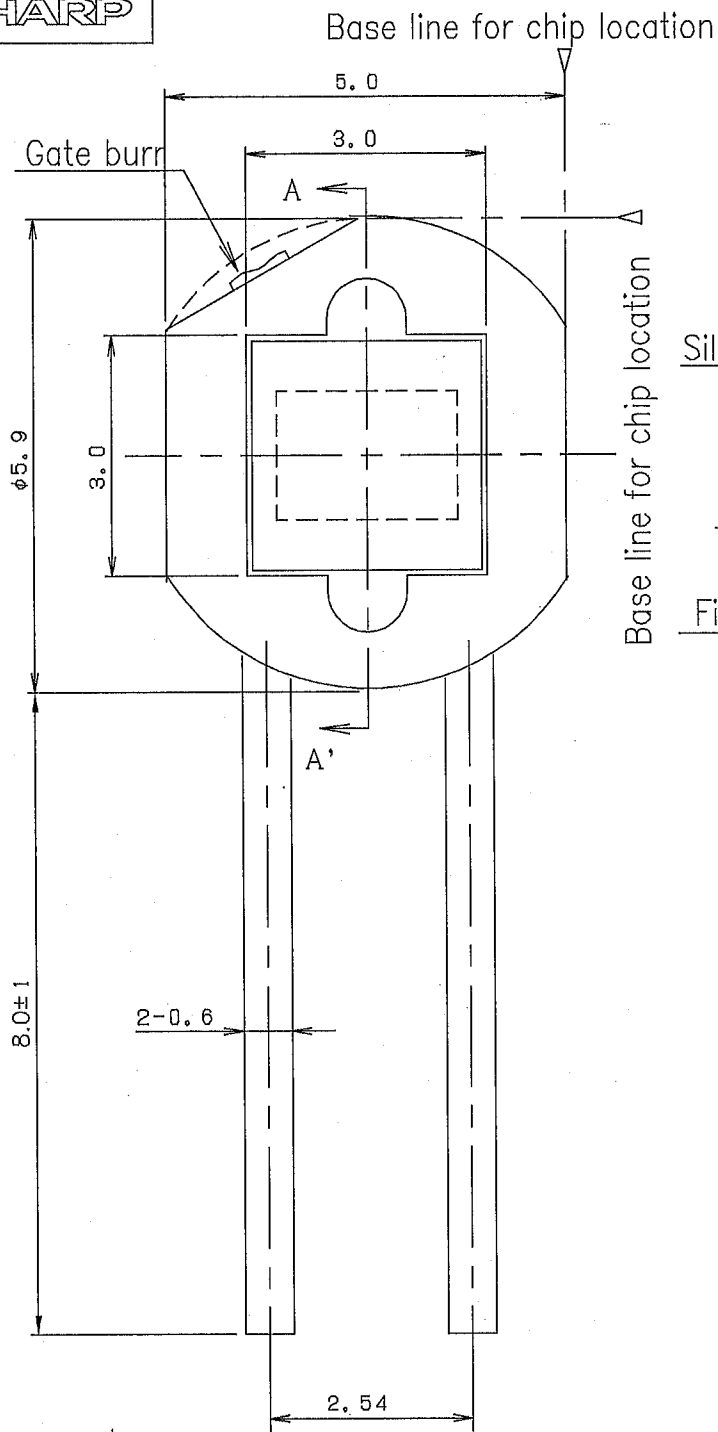

- 1) Unspecified tolerance shall be ± 0.2 .
- 2) Dimensions in parenthesis are shown for reference.
- 3) Centering accuracy of the chip is ± 0.2 mm.

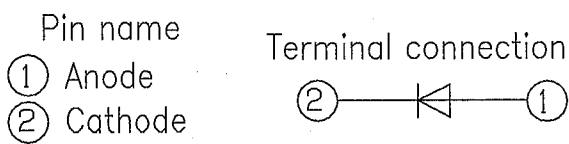

尺度 SCALE	材質 MATERIAL	仕上 FINISH	名称	BS120E0F					
10 / 1	Lead: Phosphor bronze	Lead:Solder dip	NAME	Outline Dimensions					
單位 UNIT		Lead-free solder use Composition (Standard value) Sn96.5%, Ag3.0%, Cu0.5%	圖 番	C Y 1 3 0 5 3 D 0 2					
1 = 1 / 1 mm			DRAWING No.						

3. Ratings and characteristics

3.1 Absolute maximum ratings

Ta=25°C

Parameter	Symbol	Rating	Unit
Reverse voltage	V _R	10	V
Operating temperature	Topr	-20 to +60	°C
Storage temperature	Tstg	-30 to +80	°C
Soldering temperature *	Tsol	260	°C

* Max. for 10 s at the position of 2.5mm from the resin edge

3.2 Electro-optical characteristics

Ta=25°C

Parameter	Symbol	Condition	MIN.	TYP.	MAX.	Unit
Short circuit current	I _{sc}	※1 E _v =100 lx	140	160	210	nA
Short circuit current Temperature coefficient	β T	※1 E _v =100 lx	-0.03	0.02	0.07	%/°C
Reverse voltage	V _R	I _R =1 μA	10	-	-	V
Dark current	I _d	V _R =1V, RH≤65%	-	3.0	10	pA
Dark current temperature coefficient	α T	V _R =1V, RH≤65%	-	3.5	5.0	double/10°C
Terminal capacitance	C _t	V _R =0, f=1MHz	-	-	500	pF
Spectral sensitivity infrared Radiation ratio	Δ I _R	※2 I _{sc} '/I _{sc}	-	6.0	10	%
Park emission wavelength	λ p		500	560	600	nm
Response time	t _r , t _f	R _L =100 k Ω	-	60	-	μs

※1 E_v: Illuminance by CIE standard light source A (tungsten lamp)

※2 Δ I_R=I_{sc}(700 nm or more) / (All wavelength)

3.3 Spectral sensitivity characteristics

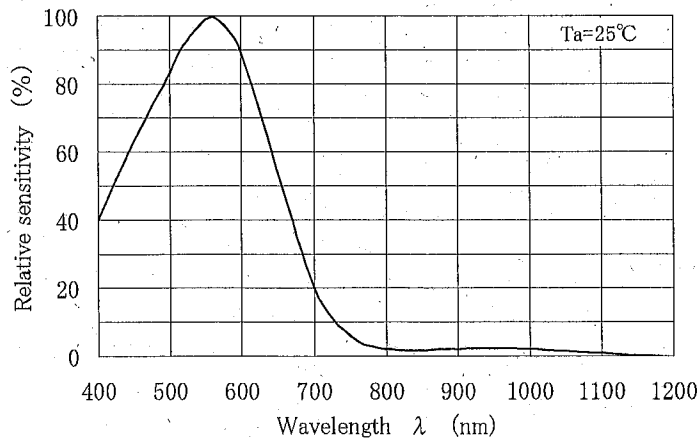

4. Reliability

The reliability of products shall satisfy items listed below.

Confidence level : 90%

LTPD : 10 or 20

Test Items	Test Conditions	Failure Judgement Criteria	Samples (n) Defective(C)
Temperature cycling	1 cycle -30°C←→+80°C (30min) (30min) 5 cycles test	After testing, leave the elements for 2 to 6 hours at the room temperature and then, perform measurement	n=22, C=0
High temp. and high humidity storage	+40°C, 90%RH, 500h		n=22, C=0
High temp. storage	+80°C, 500h		n=22, C=0
Low temp. storage	-30°C, 500h		n=22, C=0
High temperature bias	Ta= +60°C, VR=5V, 500h		n=22, C=0
Variable frequency vibration	10 to 55Hz, amplitude 1.5mm, sweep for one minute, X, Y, Z direction each 2 hours Total 6 hours	U: Upper specification limit L: Lower specification limit $I_{sc} < L \times 0.8$ $I_{sc} > U \times 1.2$ $I_d > U \times 2.0$ $\Delta I_R > U \times 1.2$	n=11, C=0
Terminal strength (Tension)	Weight: 5N 10 s/each terminal		n=11, C=0
Terminal strength (Bending)	Weight: 2.5N 0° → 90° → 0° → 90° → 0° The one test should be performed.		n=11, C=0
Soldering heat	260 ± 5°C, 10 ± 1 s Position of 2.5mm from the resin edge.		n=11, C=0
Solderability	245 ± 5°C, 5 ± 1s Position of 2.5mm from the resin edge Flux.: EC-19S (TAMURA KAKEN CO., LTD) Without pretreatment		Solder shall be adhered at less than 95% area of dipped portion.

5. Outgoing inspection

(1) Inspection lot

Inspection shall be carried out per each delivery lot.

(2) Inspection method

A single sampling plan, normal inspection level II based on ISO2859 shall be adopted.

Parameter	Inspection items and test method				AQL(%)		
Major defect	1	Disconnection, short				0.065	
	2	Inverse polarity on terminal					
	3	Characteristics defect					
		Parameter	Symbol	Judgement criteria			Unit
				MIN.	MAX.		
		Short circuit current	Isc	140	210		nA
	Reverse voltage	VR	10	-	V		
	Dark current	Id	-	10	PA		
	Test conditions refer to parameter 3.2.						
Minor defect	1	Appearance defect				0.25	
		Parameter	Judgement criteria				
		Split, Chip, Scratch Stain, Blur, Foreign matter, Bubble	One which affects the characteristics of parameter 3.2 shall be defect.				