



Chipsmall Limited consists of a professional team with an average of over 10 year of expertise in the distribution of electronic components. Based in Hongkong, we have already established firm and mutual-benefit business relationships with customers from,Europe,America and south Asia,supplying obsolete and hard-to-find components to meet their specific needs.

With the principle of “Quality Parts,Customers Priority,Honest Operation,and Considerate Service”,our business mainly focus on the distribution of electronic components. Line cards we deal with include Microchip,ALPS,ROHM,Xilinx,Pulse,ON,Everlight and Freescale. Main products comprise IC,Modules,Potentiometer,IC Socket,Relay,Connector.Our parts cover such applications as commercial,industrial, and automotives areas.

We are looking forward to setting up business relationship with you and hope to provide you with the best service and solution. Let us make a better world for our industry!



Contact us

Tel: +86-755-8981 8866 Fax: +86-755-8427 6832

Email & Skype: info@chipsmall.com Web: www.chipsmall.com

Address: A1208, Overseas Decoration Building, #122 Zhenhua RD., Futian, Shenzhen, China



BSS83

MOSFET N-channel enhancement switching transistor

Rev. 03 — 21 November 2007

Product data sheet

IMPORTANT NOTICE

Dear customer,

As from October 1st, 2006 Philips Semiconductors has a new trade name - NXP Semiconductors, which will be used in future data sheets together with new contact details.

In data sheets where the previous Philips references remain, please use the new links as shown below.

<http://www.philips.semiconductors.com> use <http://www.nxp.com>

<http://www.semiconductors.philips.com> use <http://www.nxp.com> (Internet)

sales.addresses@www.semiconductors.philips.com use salesaddresses@nxp.com (email)

The copyright notice at the bottom of each page (or elsewhere in the document, depending on the version)

- © Koninklijke Philips Electronics N.V. (year). All rights reserved -

is replaced with:

- © NXP B.V. (year). All rights reserved. -

If you have any questions related to the data sheet, please contact our nearest sales office via e-mail or phone (details via salesaddresses@nxp.com). Thank you for your cooperation and understanding,

NXP Semiconductors

MOSFET N-channel enhancement switching transistor

BSS83

DESCRIPTION

Symmetrical insulated-gate silicon MOS field-effect transistor of the N-channel enhancement mode type. The transistor is sealed in a SOT143 envelope and features a low ON resistance and low capacitances. The transistor is protected against excessive input voltages by integrated back-to-back diodes between gate and substrate.

Marking code:

BSS83 = % M9

APPLICATIONS

- analog and/or digital switch
- switch driver

PINNING

- 1 = substrate (b)
- 2 = source
- 3 = drain
- 4 = gate

Note

1. Drain and source are interchangeable.

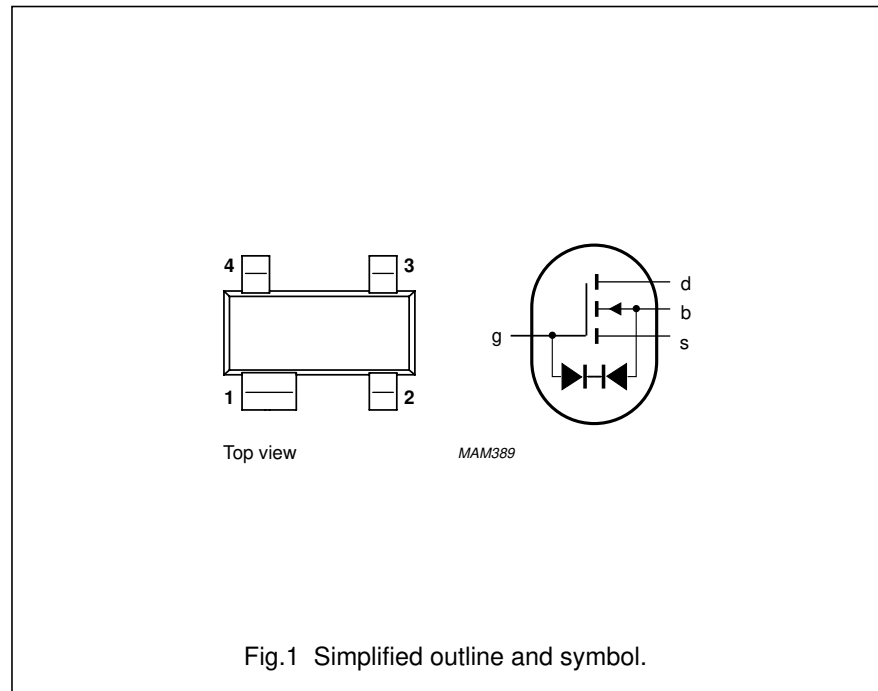

QUICK REFERENCE DATA

Drain-source voltage	V_{DS}	max.	10 V
Source-drain voltage	V_{SD}	max.	10 V
Drain-substrate voltage	V_{DB}	max.	15 V
Source-substrate voltage	V_{SB}	max.	15 V
Drain current (DC)	I_D	max.	50 mA
Total power dissipation up to $T_{amb} = 25\text{ °C}$	P_{tot}	max.	230 mW
Gate-source threshold voltage			
$V_{DS} = V_{GS}; V_{SB} = 0;$			
$I_D = 1\text{ }\mu\text{A}$	$V_{GS(th)}$	>	0.1 V
		<	2.0 V
Drain-source ON-resistance			
$V_{GS} = 10\text{ V}; V_{SB} = 0; I_D = 0.1\text{ mA}$	R_{DSon}	<	45 Ω
Feed-back capacitance			
$V_{GS} = V_{BS} = -15\text{ V};$			
$V_{DS} = 10\text{ V}; f = 1\text{ MHz}$	C_{rss}	typ.	0.6 pF

MOSFET N-channel enhancement switching transistor

BSS83**RATINGS**

Limiting values in accordance with the Absolute Maximum System (IEC 134)

Drain-source voltage	V_{DS}	max.	10 V
Source-drain voltage	V_{SD}	max.	10 V
Drain-substrate voltage	V_{DB}	max.	15 V
Source-substrate voltage	V_{SB}	max.	15 V
Drain current (DC)	I_D	max.	50 mA
Total power dissipation up to $T_{amb} = 25\text{ °C}^{(1)}$	P_{tot}	max.	230 mW
Storage temperature range	T_{stg}		-65 to + 150 °C
Junction temperature	T_j	max.	125 °C

THERMAL RESISTANCE

From junction to ambient in free air ⁽¹⁾	$R_{th\ j-a}$	=	430 K/W
---	---------------	---	---------

MOSFET N-channel enhancement switching transistor

BSS83

CHARACTERISTICS $T_{amb} = 25\text{ °C}$ unless otherwise specified

Drain-source breakdown voltage $V_{GS} = V_{BS} = -5\text{ V}$; $I_D = 10\text{ nA}$	$V_{(BR)DSX}$	>	10 V
Source-drain breakdown voltage $V_{GD} = V_{BD} = -5\text{ V}$; $I_D = 10\text{ nA}$	$V_{(BR)SDX}$	>	10 V
Drain-substrate breakdown voltage $V_{GB} = 0$; $I_D = 10\text{ nA}$; open source	$V_{(BR)DBO}$	>	15 V
Source-substrate breakdown voltage $V_{GB} = 0$; $I_D = 10\text{ nA}$; open drain	$V_{(BR)SBO}$	>	15 V
Drain-source leakage current $V_{GS} = V_{BS} = -2\text{ V}$; $V_{DS} = 6,6\text{ V}$	$I_{D\text{Soff}}$	<	10 nA
Source-drain leakage current $V_{GD} = V_{BD} = -2\text{ V}$; $V_{SD} = 6,6\text{ V}$	$I_{S\text{Doff}}$	<	10 nA
Forward transconductance at $f = 1\text{ kHz}$ $V_{DS} = 10\text{ V}$; $V_{SB} = 0$; $I_D = 20\text{ mA}$	g_{fs}	> typ.	10 mS 15 mS
Gate-source threshold voltage $V_{DS} = V_{GS}$; $V_{SB} = 0$; $I_D = 1\text{ }\mu\text{A}$	$V_{GS(th)}$	> <	0,1 V 2,0 V
Drain-source ON-resistance $I_D = 0,1\text{ mA}$; $V_{GS} = 5\text{ V}$; $V_{SB} = 0$ $V_{GS} = 10\text{ V}$; $V_{SB} = 0$ $V_{GS} = 3,2\text{ V}$; $V_{SB} = 6,8\text{ V}$ (see Fig.4)	R_{DSon}	< < typ. <	70 Ω 45 Ω 80 Ω 120 Ω
Gate-substrate zener voltages $V_{DB} = V_{SB} = 0$; $-I_G = 10\text{ }\mu\text{A}$ $V_{DB} = V_{SB} = 0$; $+I_G = 10\text{ }\mu\text{A}$	$V_{Z(1)}$ $V_{Z(2)}$	> >	12,5 V 12,5 V
Capacitances at $f = 1\text{ MHz}$ $V_{GS} = V_{BS} = -15\text{ V}$; $V_{DS} = 10\text{ V}$			
Feed-back capacitance	C_{rss}	typ.	0,6 pF
Input capacitance	C_{iss}	typ.	1,5 pF
Output capacitance	C_{oss}	typ.	1,0 pF
Switching times (see Fig.2) $V_{DD} = 10\text{ V}$; $V_i = 5\text{ V}$	t_{on} t_{off}	typ. typ.	1,0 ns 5,0 ns

Note

1. Device mounted on a ceramic substrate of $8\text{ mm} \times 10\text{ mm} \times 0,7\text{ mm}$.

MOSFET N-channel enhancement switching transistor

BSS83

Pulse generator:

- $R_i = 50 \Omega$
- $t_r < 0,5 \text{ ns}$
- $t_f < 1,0 \text{ ns}$
- $t_p = 20 \text{ ns}$
- $\delta < 0,01$

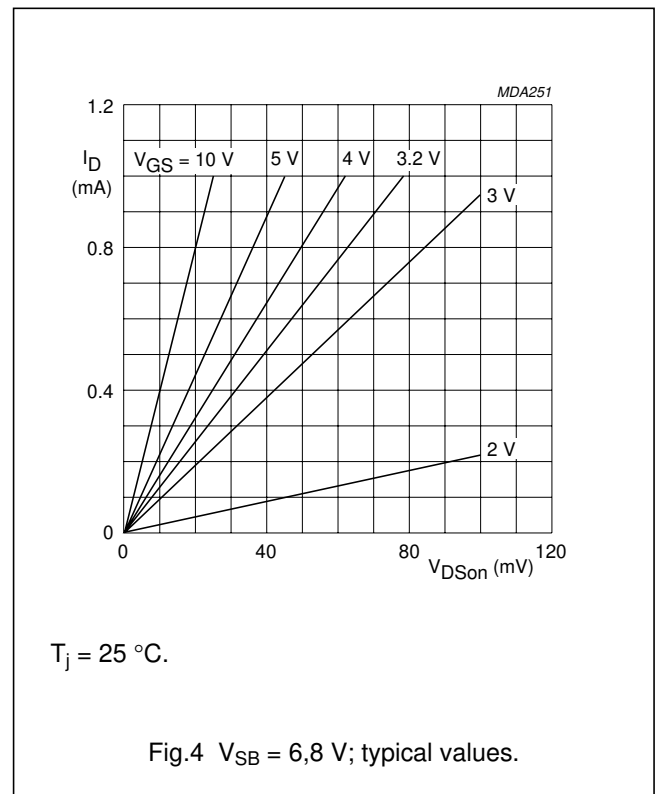
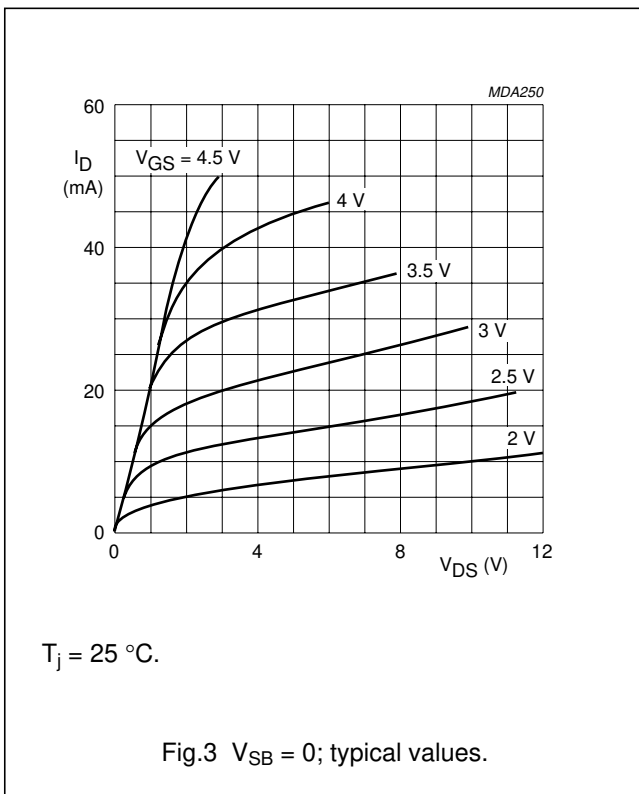
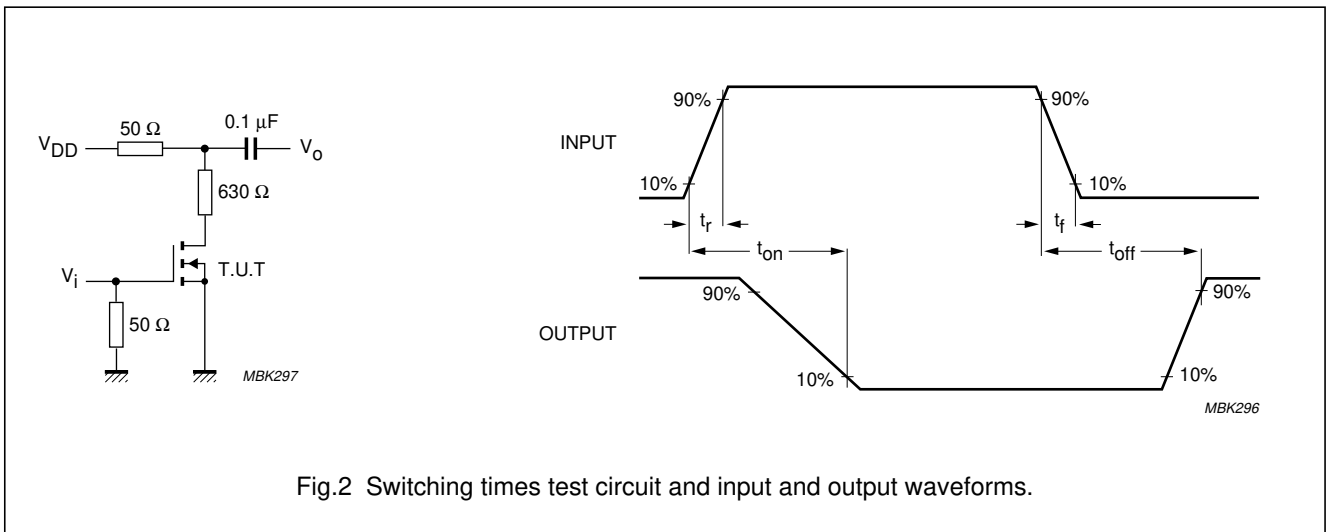

MOSFET N-channel enhancement switching transistor

BSS83

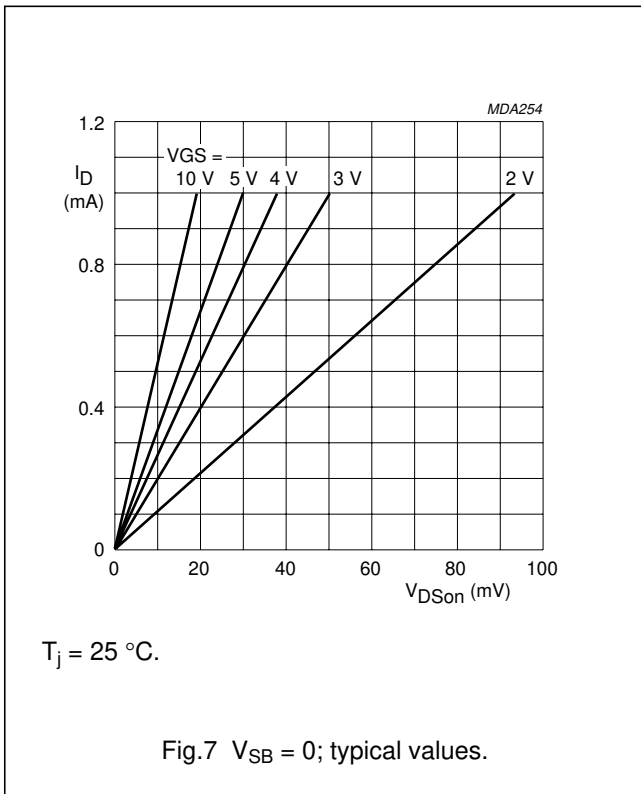
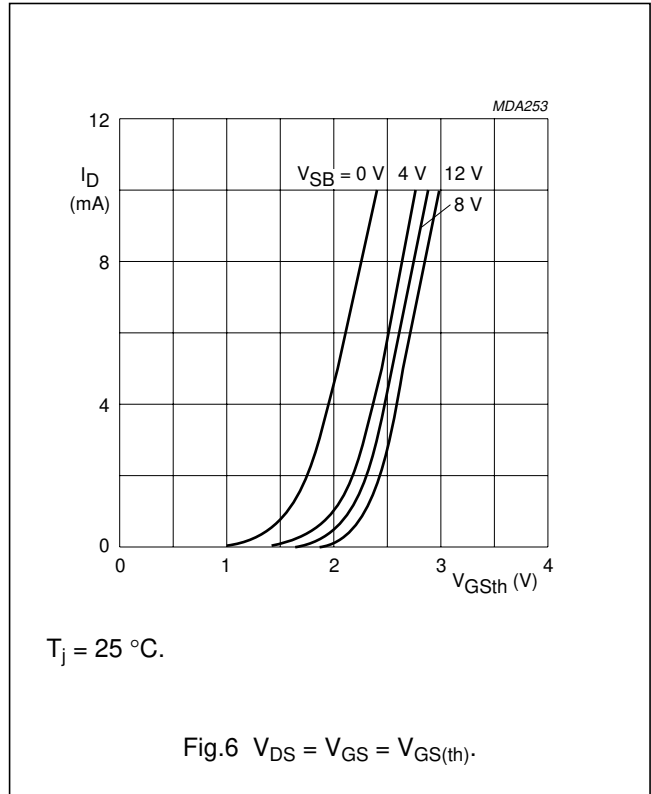
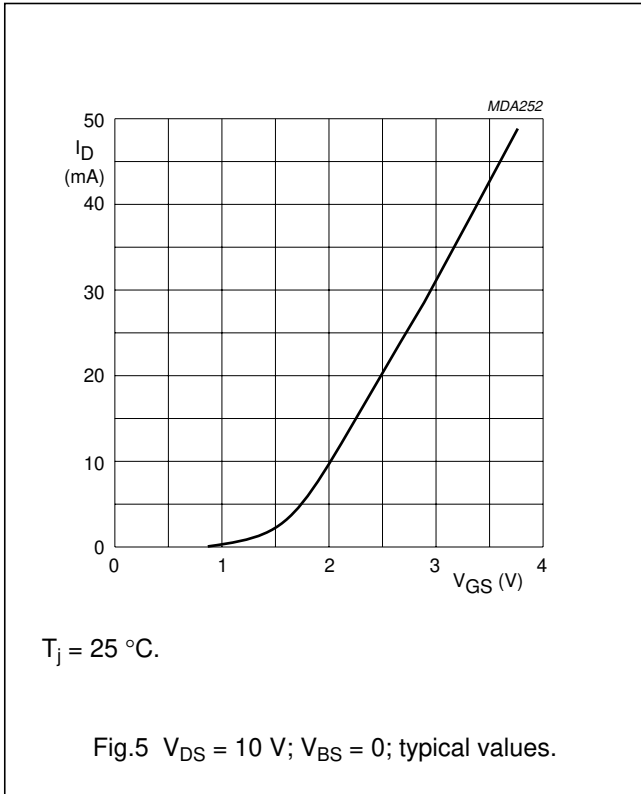

MOSFET N-channel enhancement switching transistor

BSS83

PACKAGE OUTLINE

Plastic surface mounted package; 4 leads

SOT143B

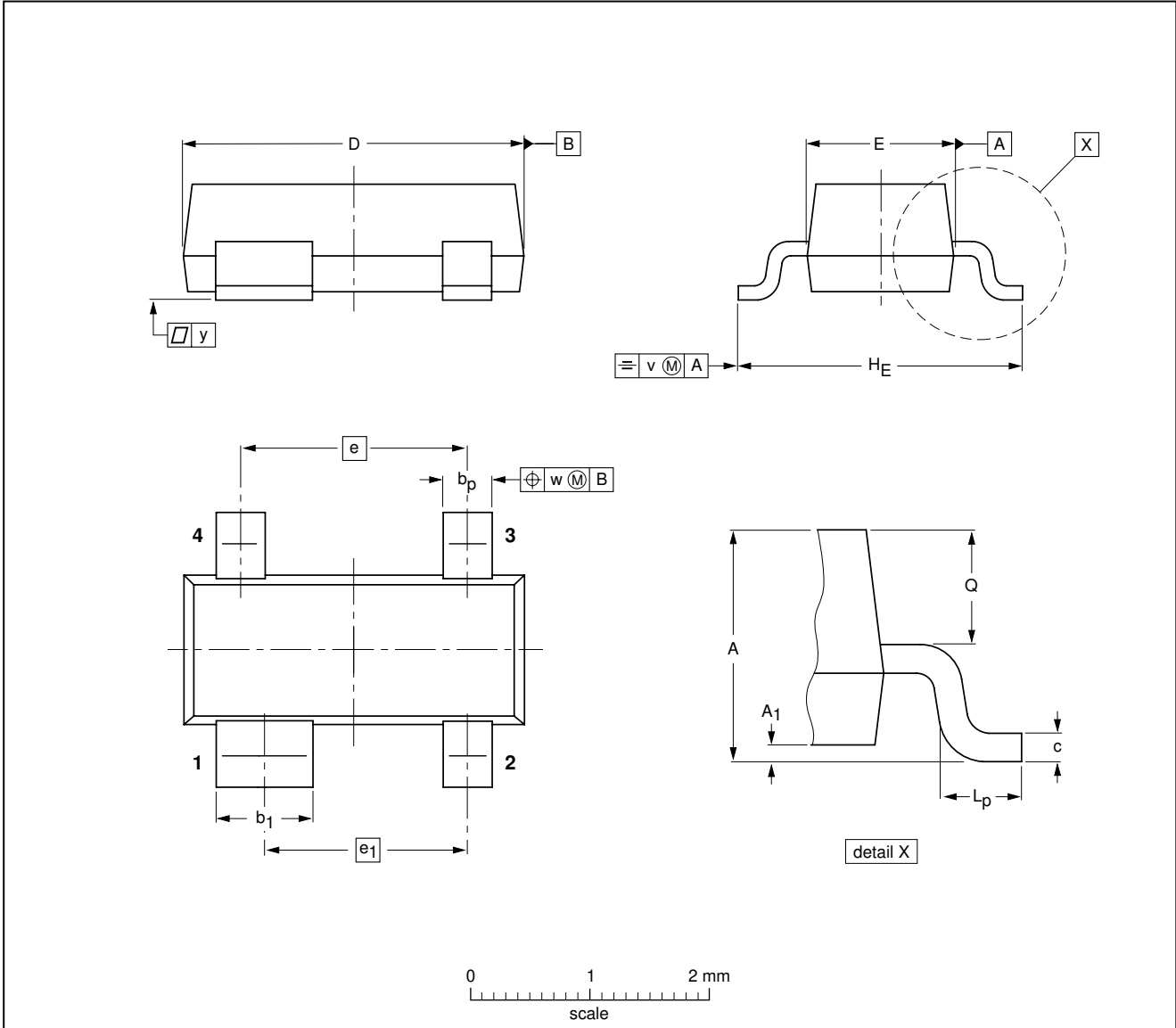

DIMENSIONS (mm are the original dimensions)

UNIT	A	A ₁ max	b _p	b ₁	c	D	E	e	e ₁	H _E	L _p	Q	v	w	y
mm	1.1 0.9	0.1	0.48 0.38	0.88 0.78	0.15 0.09	3.0 2.8	1.4 1.2	1.9	1.7	2.5 2.1	0.45 0.15	0.55 0.45	0.2	0.1	0.1

OUTLINE VERSION	REFERENCES				EUROPEAN PROJECTION	ISSUE DATE
	IEC	JEDEC	EIAJ			
SOT143B						97-02-28

Legal information

Data sheet status

Document status ^{[1][2]}	Product status ^[3]	Definition
Objective [short] data sheet	Development	This document contains data from the objective specification for product development.
Preliminary [short] data sheet	Qualification	This document contains data from the preliminary specification.
Product [short] data sheet	Production	This document contains the product specification.

[1] Please consult the most recently issued document before initiating or completing a design.

[2] The term 'short data sheet' is explained in section "Definitions".

[3] The product status of device(s) described in this document may have changed since this document was published and may differ in case of multiple devices. The latest product status information is available on the Internet at URL <http://www.nxp.com>.

Definitions

Draft — The document is a draft version only. The content is still under internal review and subject to formal approval, which may result in modifications or additions. NXP Semiconductors does not give any representations or warranties as to the accuracy or completeness of information included herein and shall have no liability for the consequences of use of such information.

Short data sheet — A short data sheet is an extract from a full data sheet with the same product type number(s) and title. A short data sheet is intended for quick reference only and should not be relied upon to contain detailed and full information. For detailed and full information see the relevant full data sheet, which is available on request via the local NXP Semiconductors sales office. In case of any inconsistency or conflict with the short data sheet, the full data sheet shall prevail.

Disclaimers

General — Information in this document is believed to be accurate and reliable. However, NXP Semiconductors does not give any representations or warranties, expressed or implied, as to the accuracy or completeness of such information and shall have no liability for the consequences of use of such information.

Right to make changes — NXP Semiconductors reserves the right to make changes to information published in this document, including without limitation specifications and product descriptions, at any time and without notice. This document supersedes and replaces all information supplied prior to the publication hereof.

Suitability for use — NXP Semiconductors products are not designed, authorized or warranted to be suitable for use in medical, military, aircraft, space or life support equipment, nor in applications where failure or

malfunction of an NXP Semiconductors product can reasonably be expected to result in personal injury, death or severe property or environmental damage. NXP Semiconductors accepts no liability for inclusion and/or use of NXP Semiconductors products in such equipment or applications and therefore such inclusion and/or use is at the customer's own risk.

Applications — Applications that are described herein for any of these products are for illustrative purposes only. NXP Semiconductors makes no representation or warranty that such applications will be suitable for the specified use without further testing or modification.

Limiting values — Stress above one or more limiting values (as defined in the Absolute Maximum Ratings System of IEC 60134) may cause permanent damage to the device. Limiting values are stress ratings only and operation of the device at these or any other conditions above those given in the Characteristics sections of this document is not implied. Exposure to limiting values for extended periods may affect device reliability.

Terms and conditions of sale — NXP Semiconductors products are sold subject to the general terms and conditions of commercial sale, as published at <http://www.nxp.com/profile/terms>, including those pertaining to warranty, intellectual property rights infringement and limitation of liability, unless explicitly otherwise agreed to in writing by NXP Semiconductors. In case of any inconsistency or conflict between information in this document and such terms and conditions, the latter will prevail.

No offer to sell or license — Nothing in this document may be interpreted or construed as an offer to sell products that is open for acceptance or the grant, conveyance or implication of any license under any copyrights, patents or other industrial or intellectual property rights.

Trademarks

Notice: All referenced brands, product names, service names and trademarks are the property of their respective owners.

Contact information

For additional information, please visit: <http://www.nxp.com>

For sales office addresses, send an email to: salesaddresses@nxp.com

Revision history

Revision history

Document ID	Release date	Data sheet status	Change notice	Supersedes
BSS83_N_3	20071121	Product data sheet	-	BSS83_CNV_2
Modifications:	• Page 2; column 2; Marking code; row 1 changed			
BSS83_CNV_2	19910401	Product specification	-	-

Please be aware that important notices concerning this document and the product(s) described herein, have been included in section 'Legal information'.

founded by

PHILIPS

© NXP B.V. 2007.

All rights reserved.

For more information, please visit: <http://www.nxp.com>

For sales office addresses, please send an email to: salesaddresses@nxp.com

Date of release: 21 November 2007

Document identifier: BSS83_N_3