



Chipsmall Limited consists of a professional team with an average of over 10 year of expertise in the distribution of electronic components. Based in Hongkong, we have already established firm and mutual-benefit business relationships with customers from,Europe,America and south Asia,supplying obsolete and hard-to-find components to meet their specific needs.

With the principle of "Quality Parts,Customers Priority,Honest Operation,and Considerate Service",our business mainly focus on the distribution of electronic components. Line cards we deal with include Microchip,ALPS,ROHM,Xilinx,Pulse,ON,Everlight and Freescale. Main products comprise IC,Modules,Potentiometer,IC Socket,Relay,Connector.Our parts cover such applications as commercial,industrial, and automotives areas.

We are looking forward to setting up business relationship with you and hope to provide you with the best service and solution. Let us make a better world for our industry!



Contact us

Tel: +86-755-8981 8866 Fax: +86-755-8427 6832

Email & Skype: info@chipsmall.com Web: www.chipsmall.com

Address: A1208, Overseas Decoration Building, #122 Zhenhua RD., Futian, Shenzhen, China



DATA SHEET

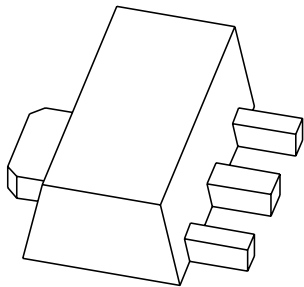

BST50; BST51; BST52 NPN Darlington transistors

Product specification
Supersedes data of 2001 Feb 20

2004 Dec 09

NPN Darlington transistors

BST50; BST51; BST52

FEATURES

- High current (max. 0.5 A)
- Low voltage (max. 80 V)
- Integrated diode and resistor.

APPLICATIONS

- Industrial switching applications such as:
 - Print hammer
 - Solenoid
 - Relay and lamp driving.

DESCRIPTION

NPN Darlington transistor in a SOT89 plastic package.
PNP complements: BST60, BST61 and BST62.

MARKING

TYPE NUMBER	MARKING CODE
BST50	AS1
BST51	AS2
BST52	AS3

PINNING

PIN	DESCRIPTION
1	emitter
2	collector
3	base

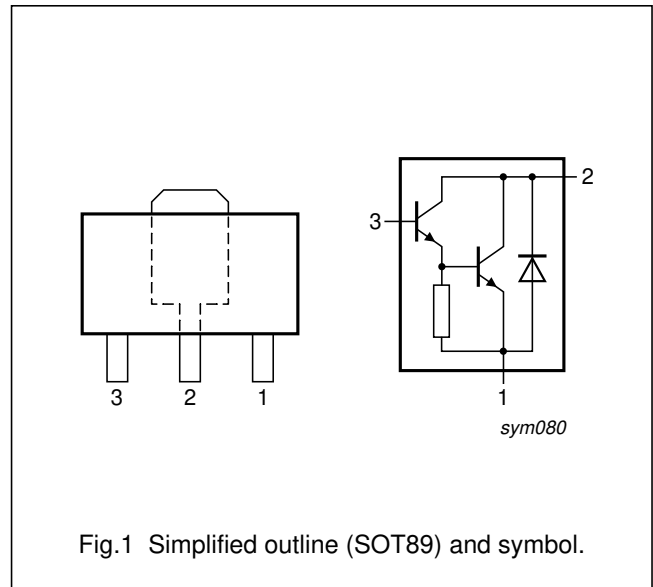

ORDERING INFORMATION

TYPE NUMBER	PACKAGE		
	NAME	DESCRIPTION	VERSION
BST50	SC-62	plastic surface mounted package; collector pad for good heat transfer; 3 leads	SOT89
BST51			
BST52			

NPN Darlington transistors

BST50; BST51; BST52

LIMITING VALUES

In accordance with the Absolute Maximum Rating System (IEC 60134).

SYMBOL	PARAMETER	CONDITIONS	MIN.	MAX.	UNIT
V _{CBO}	collector-base voltage	open emitter			
	BST50		–	60	V
	BST51		–	80	V
	BST52		–	90	V
V _{CES}	collector-emitter voltage	V _{BE} = 0 V			
	BST50		–	45	V
	BST51		–	60	V
	BST52		–	80	V
V _{EBO}	emitter-base voltage	open collector	–	5	V
I _C	collector current (DC)		–	1	A
I _{CM}	peak collector current		–	2	A
I _B	base current (DC)		–	100	mA
P _{tot}	total power dissipation	T _{amb} ≤ 25 °C; note 1	–	1.3	W
T _j	junction temperature		–	150	°C
T _{amb}	ambient temperature		–65	+150	°C
T _{stg}	storage temperature		–65	+150	°C

Note

- Device mounted on a printed-circuit board, single-sided copper, tin-plated, mounting pad for collector 6 cm².
For other mounting conditions, see “*Thermal considerations for SOT89 in the General Part of associated Handbook*”.

THERMAL CHARACTERISTICS

SYMBOL	PARAMETER	CONDITIONS	VALUE	UNIT
R _{th(j-a)}	thermal resistance from junction to ambient	note 1	96	K/W
R _{th(j-s)}	thermal resistance from junction to soldering point		16	K/W

Note

- Device mounted on a printed-circuit board, single-sided copper, tin-plated, mounting pad for collector 6 cm².
For other mounting conditions, see “*Thermal considerations for SOT89 in the General Part of associated Handbook*”.

NPN Darlington transistors

BST50; BST51; BST52

CHARACTERISTICS

$T_{amb} = 25\text{ °C}$ unless otherwise specified.

SYMBOL	PARAMETER	CONDITIONS	MIN.	TYP.	MAX.	UNIT
I_{CES}	collector-emitter cut-off current					
	BST50	$V_{BE} = 0\text{ V}; V_{CE} = 45\text{ V}$	–	–	50	nA
	BST51	$V_{BE} = 0\text{ V}; V_{CE} = 60\text{ V}$	–	–	50	nA
	BST52	$V_{BE} = 0\text{ V}; V_{CE} = 80\text{ V}$	–	–	50	nA
I_{EBO}	emitter-base cut-off current	$I_C = 0\text{ A}; V_{EB} = 4\text{ V}$	–	–	50	nA
h_{FE}	DC current gain	$V_{CE} = 10\text{ V}$; note 1; (see Fig.2)				
		$I_C = 150\text{ mA}$	1000	–	–	
		$I_C = 500\text{ mA}$	2000	–	–	
V_{CEsat}	collector-emitter saturation voltage	$I_C = 500\text{ mA}; I_B = 0.5\text{ mA}$	–	–	1.3	V
		$I_C = 500\text{ mA}; I_B = 0.5\text{ mA}; T_j = 150\text{ °C}$	–	–	1.3	V
V_{BEsat}	base-emitter saturation voltage	$I_C = 500\text{ mA}; I_B = 0.5\text{ mA}$	–	–	1.9	V
f_T	transition frequency	$I_C = 500\text{ mA}; V_{CE} = 5\text{ V}; f = 100\text{ MHz}$	–	200	–	MHz
Switching times (between 10% and 90% levels); (see Fig.3)						
t_{on}	turn-on time	$I_{Con} = 500\text{ mA}; I_{Bon} = 0.5\text{ mA}; I_{Boff} = -0.5\text{ mA}$	–	400	–	ns
t_{off}	turn-off time		–	1500	–	ns

Note

1. Pulse test: $t_p \leq 300\text{ }\mu\text{s}$; $\delta \leq 0.02$.

NPN Darlington transistors

BST50; BST51; BST52

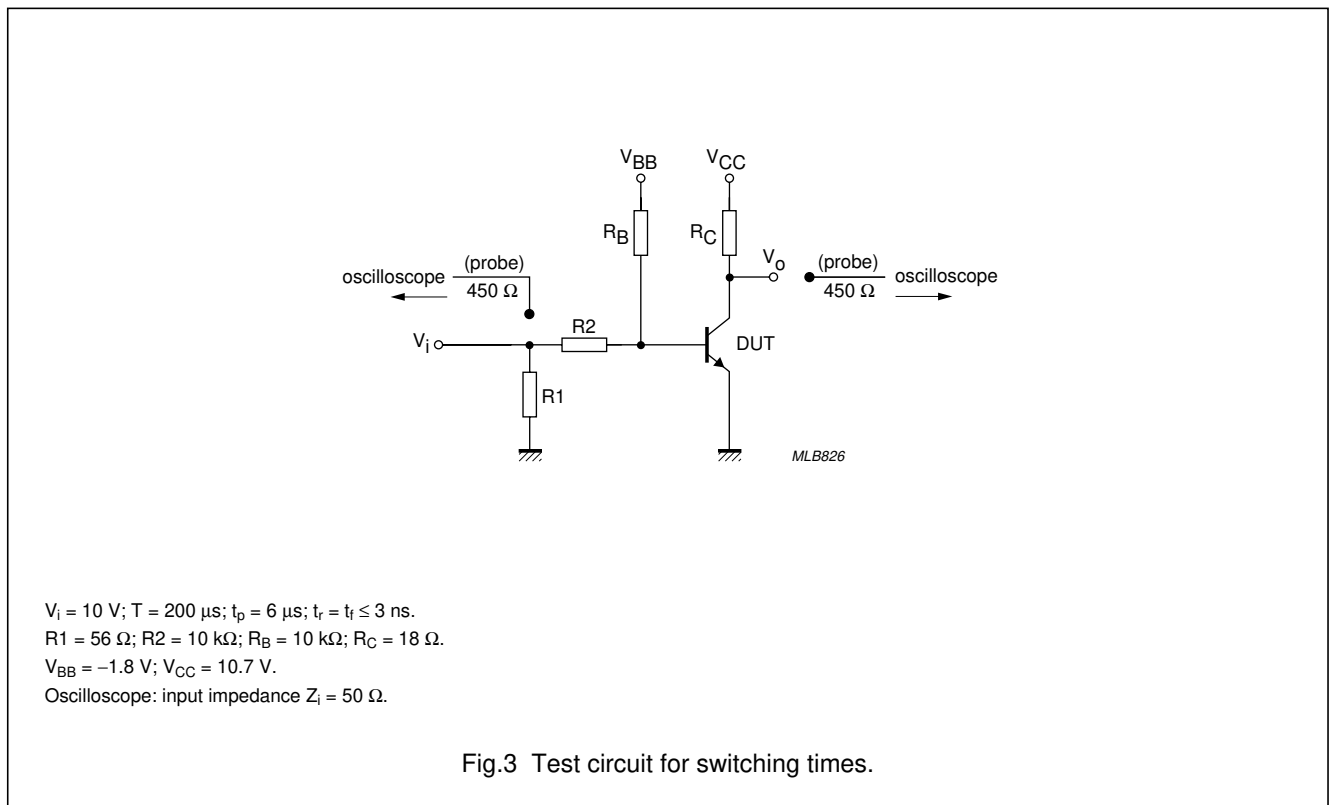
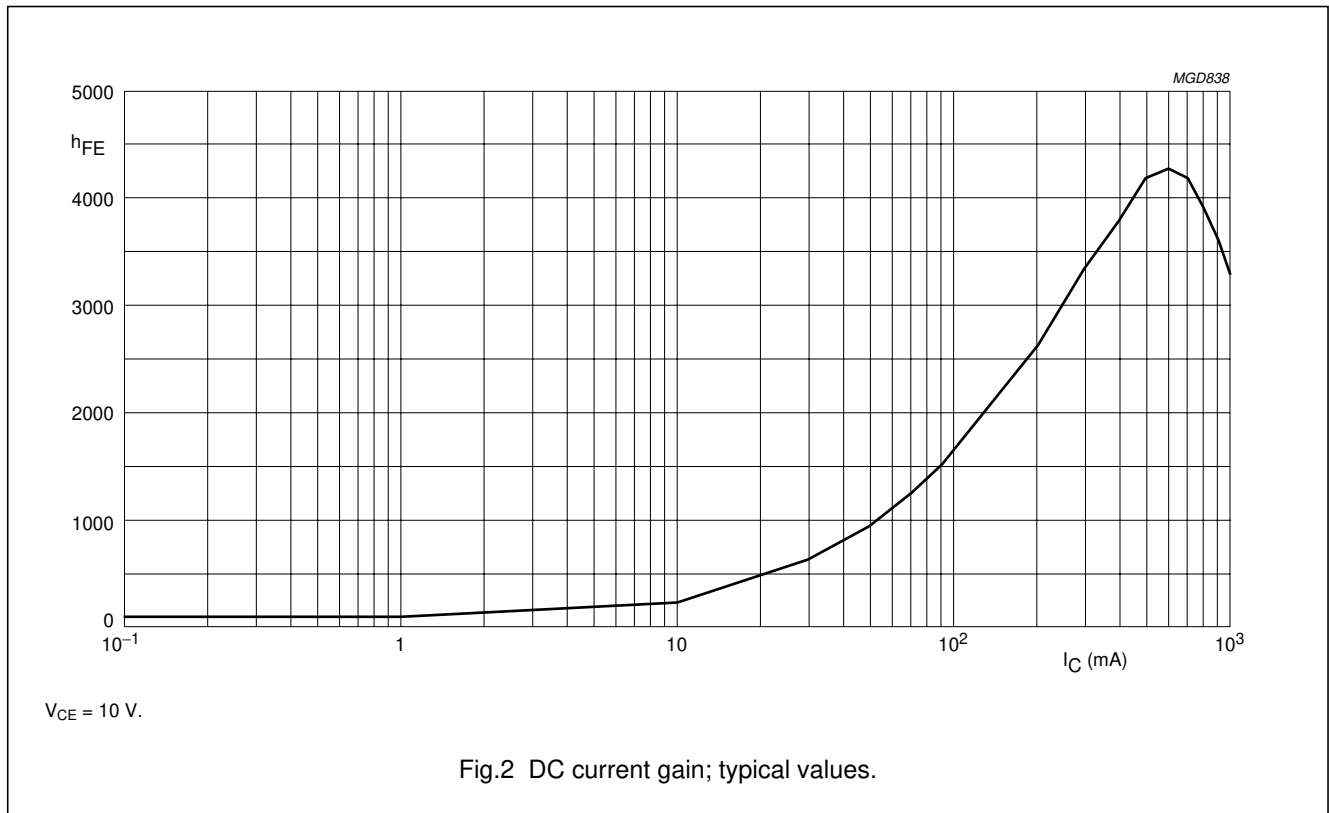

NPN Darlington transistors

BST50; BST51; BST52

PACKAGE OUTLINE

Plastic surface mounted package; collector pad for good heat transfer; 3 leads

SOT89

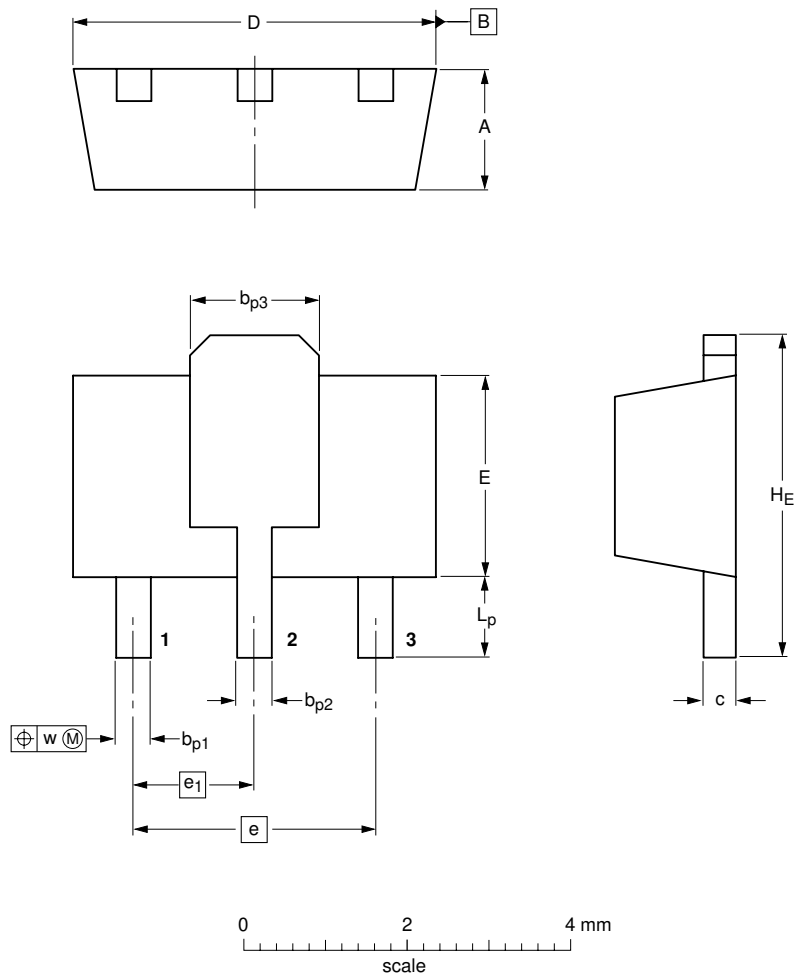

DIMENSIONS (mm are the original dimensions)

UNIT	A	b _{p1}	b _{p2}	b _{p3}	c	D	E	e	e ₁	H _E	L _p	w
mm	1.6 1.4	0.48 0.35	0.53 0.40	1.8 1.4	0.44 0.23	4.6 4.4	2.6 2.4	3.0	1.5	4.25 3.75	1.2 0.8	0.13

OUTLINE VERSION	REFERENCES			EUROPEAN PROJECTION	ISSUE DATE
	IEC	JEDEC	JEITA		
SOT89		TO-243	SC-62		99-09-13 04-08-03

NPN Darlington transistors

BST50; BST51; BST52

DATA SHEET STATUS

LEVEL	DATA SHEET STATUS ⁽¹⁾	PRODUCT STATUS ⁽²⁾⁽³⁾	DEFINITION
I	Objective data	Development	This data sheet contains data from the objective specification for product development. Philips Semiconductors reserves the right to change the specification in any manner without notice.
II	Preliminary data	Qualification	This data sheet contains data from the preliminary specification. Supplementary data will be published at a later date. Philips Semiconductors reserves the right to change the specification without notice, in order to improve the design and supply the best possible product.
III	Product data	Production	This data sheet contains data from the product specification. Philips Semiconductors reserves the right to make changes at any time in order to improve the design, manufacturing and supply. Relevant changes will be communicated via a Customer Product/Process Change Notification (CPCN).

Notes

1. Please consult the most recently issued data sheet before initiating or completing a design.
2. The product status of the device(s) described in this data sheet may have changed since this data sheet was published. The latest information is available on the Internet at URL <http://www.semiconductors.philips.com>.
3. For data sheets describing multiple type numbers, the highest-level product status determines the data sheet status.

DEFINITIONS

Short-form specification — The data in a short-form specification is extracted from a full data sheet with the same type number and title. For detailed information see the relevant data sheet or data handbook.

Limiting values definition — Limiting values given are in accordance with the Absolute Maximum Rating System (IEC 60134). Stress above one or more of the limiting values may cause permanent damage to the device. These are stress ratings only and operation of the device at these or at any other conditions above those given in the Characteristics sections of the specification is not implied. Exposure to limiting values for extended periods may affect device reliability.

Application information — Applications that are described herein for any of these products are for illustrative purposes only. Philips Semiconductors make no representation or warranty that such applications will be suitable for the specified use without further testing or modification.

DISCLAIMERS

Life support applications — These products are not designed for use in life support appliances, devices, or systems where malfunction of these products can reasonably be expected to result in personal injury. Philips Semiconductors customers using or selling these products for use in such applications do so at their own risk and agree to fully indemnify Philips Semiconductors for any damages resulting from such application.

Right to make changes — Philips Semiconductors reserves the right to make changes in the products - including circuits, standard cells, and/or software - described or contained herein in order to improve design and/or performance. When the product is in full production (status 'Production'), relevant changes will be communicated via a Customer Product/Process Change Notification (CPCN). Philips Semiconductors assumes no responsibility or liability for the use of any of these products, conveys no licence or title under any patent, copyright, or mask work right to these products, and makes no representations or warranties that these products are free from patent, copyright, or mask work right infringement, unless otherwise specified

Philips Semiconductors – a worldwide company

Contact information

For additional information please visit <http://www.semiconductors.philips.com>. Fax: +31 40 27 24825

For sales offices addresses send e-mail to: sales.addresses@www.semiconductors.philips.com.

© Koninklijke Philips Electronics N.V. 2004

SCA76

All rights are reserved. Reproduction in whole or in part is prohibited without the prior written consent of the copyright owner.

The information presented in this document does not form part of any quotation or contract, is believed to be accurate and reliable and may be changed without notice. No liability will be accepted by the publisher for any consequence of its use. Publication thereof does not convey nor imply any license under patent- or other industrial or intellectual property rights.

Printed in The Netherlands

R75/05/pp8

Date of release: 2004 Dec 09

Document order number: 9397 750 13877

Let's make things better.

**Philips
Semiconductors**



PHILIPS