



Chipsmall Limited consists of a professional team with an average of over 10 year of expertise in the distribution of electronic components. Based in Hongkong, we have already established firm and mutual-benefit business relationships with customers from,Europe,America and south Asia,supplying obsolete and hard-to-find components to meet their specific needs.

With the principle of “Quality Parts,Customers Priority,Honest Operation,and Considerate Service”,our business mainly focus on the distribution of electronic components. Line cards we deal with include Microchip,ALPS,ROHM,Xilinx,Pulse,ON,Everlight and Freescale. Main products comprise IC,Modules,Potentiometer,IC Socket,Relay,Connector.Our parts cover such applications as commercial,industrial, and automotives areas.

We are looking forward to setting up business relationship with you and hope to provide you with the best service and solution. Let us make a better world for our industry!



Contact us

Tel: +86-755-8981 8866 Fax: +86-755-8427 6832

Email & Skype: info@chipsmall.com Web: www.chipsmall.com

Address: A1208, Overseas Decoration Building, #122 Zhenhua RD., Futian, Shenzhen, China



Bluetooth 5 Modules with Amplifier, BT832X and BT832XE

BluNor BT832X is a powerful, highly flexible, Bluetooth Low Energy (BLE) using Nordic nRF52832 SoC. With an ARM Cortex™ M4F MCU, available 512KB flash, 64KB RAM, embedded 2.4GHz multi-protocol transceiver, power amplifier, and an integrated PCB trace antenna, or an u.FL connector for external antenna. It allows faster time to market with reduced development cost.

For applications needing limited number of IO pins, prototyping and production are easier using 16 castellated pins. Additional 24 LGA (Land Grid Array) pins provide access to 29 GPIOs of nRF52832.

Line of sight range between 2 BT832X is 1170 meters. Ranges between 2 BT832XE with ANT060 external antenna is 1350 meters.



Specifications:

- Nordic nRF52832 with ARM Cortex M4F.
- Integrated DC-DC converter, inductors on board
- Serial Wire Debug (SWD)
- Nordic SoftDevice Ready
- Over-the-Air (OTA) firmware update
- Flash/RAM: 512KB/64KB
- 29 GPIO pins
- 12 bit/200KSPS ADC, 8 configurable channels with programmable gain.
- 3X SPI Master/Slave (8Mbps)
- 3X 4-channel pulse width modulator (PWM)
- Low power comparator
- 2X 2-wire Master/Slave (I²C compatible)
- I2S audio interface
- UART (with CTS/RTS and DMA)
- 20 channel CPU independent Programmable Peripheral Interconnect (PPI).
- Quadrature Demodulator (QDEC)
- 128-bit AES HW encryption
- 5 x 32 bits, 3 x 24 bits Real Time Counters (RTC)
- NFC-A tag interface for OOB pairing
- Receiver Sensitivity: -105 dBm
- TX power: +20 dBm
- Sizes: 15.0x28.0x1.9mm
- Hybrid pins: 16 castellated and 24 LGA.
- Integrated 32.768 kHz sleep crystal
- BT832X with an Integrated high performance PCB trace antenna
- BT832XE with an u.FL for external antenna
- Operation voltage: 1.8V to 3.6V
- FCC ID: X8WBT832XE
- IC ID: 4100A-BT832XE
- QDID: 97989
- Operation temperature: -40° C to +85° C

Applications

- IoT (Internet of Things)
- Beacons
- Fitness/Sports
- Connected appliances
- Lighting products
- Sensors
- Home and building automation
- Long range equipment tracking
- Drone remote control
- Video and audio transmission

Model Summaries

module	BT832X	BT832XE
SoC	nRF52832-QFAA	nRF52832-QFAA
Flash/RAM	512KB/64KB	512KB/64KB
BT Antenna	PCB trace	u.FL
Range at 1Mbps	1170 meters	1350 meters with ANT060
Availability	Production	Production

Table Of Contents

1. Introduction.....	3
BT832X Block Diagram	3
BT832X.....	3
BT832XE with ANT060.....	4
Antennas ANT060 and ANT061	4
2. Codes Development Using Nordic Tools.....	5
Easy, fast and safe code development.....	5
Over-The-Air DFU	5
SoftDevices	5
Development Tools	5
3. Product Overview	6
Block Diagram of nRF52832	6
Mechanical Drawings	8
Pin Assignments of BT832X.....	9
Pin Functions.....	10
Host PCB Layout Guidelines	11
Mounting BT832X on the Host PCB.....	12
Control Skyworks Power Amplifier.....	13
4. AT Commands.....	15
Brief description of AT commands	15
Command mode.....	16
Data Mode	19
Communicating with a PC	19
5. Evaluation Boards and Reference Designs.....	19
Schematics and Gerber Files	19
Evaluation Board EV BT832X Schematics.....	20
6. Bluetooth Line of Sight Range Measurements.....	21
Test Conditions	21
Measurement results	21
Conclusions and suggestions for deployment	22
7. Miscellaneous.....	23
Soldering Temperature-Time Profile for Re-Flow Soldering	23
Cautions, Design Notes, and Installation Notes	23
Packaging.....	26
FCC Label	26
Revision History	27
Contact Us	28

1. Introduction

BluNor BT832X is powerful, highly flexible, ultra low power Bluetooth Low Energy (BLE) modules using Nordic nRF52832 SoCs. With an ARM Cortex™ M4F MCU, available 512KB flash, 64KB RAM, embedded 2.4GHz multi-protocol transceiver, power amplifier, and an integrated antenna or an u.FL connector for external antenna, it allows faster time to market with reduced development cost.

The following is a block diagram of BT832X. Antenna circuit, 32 MHz main clock, and 32.768 KHz sleep clock are integrated. Three GPIOs are used to control SKY66112 power amplifier. The other 29 GPIOs of nRF52832 can be accessed from main board. Connection to an external NFC (Near Field Communication) antenna is provided.

BT832X Block Diagram

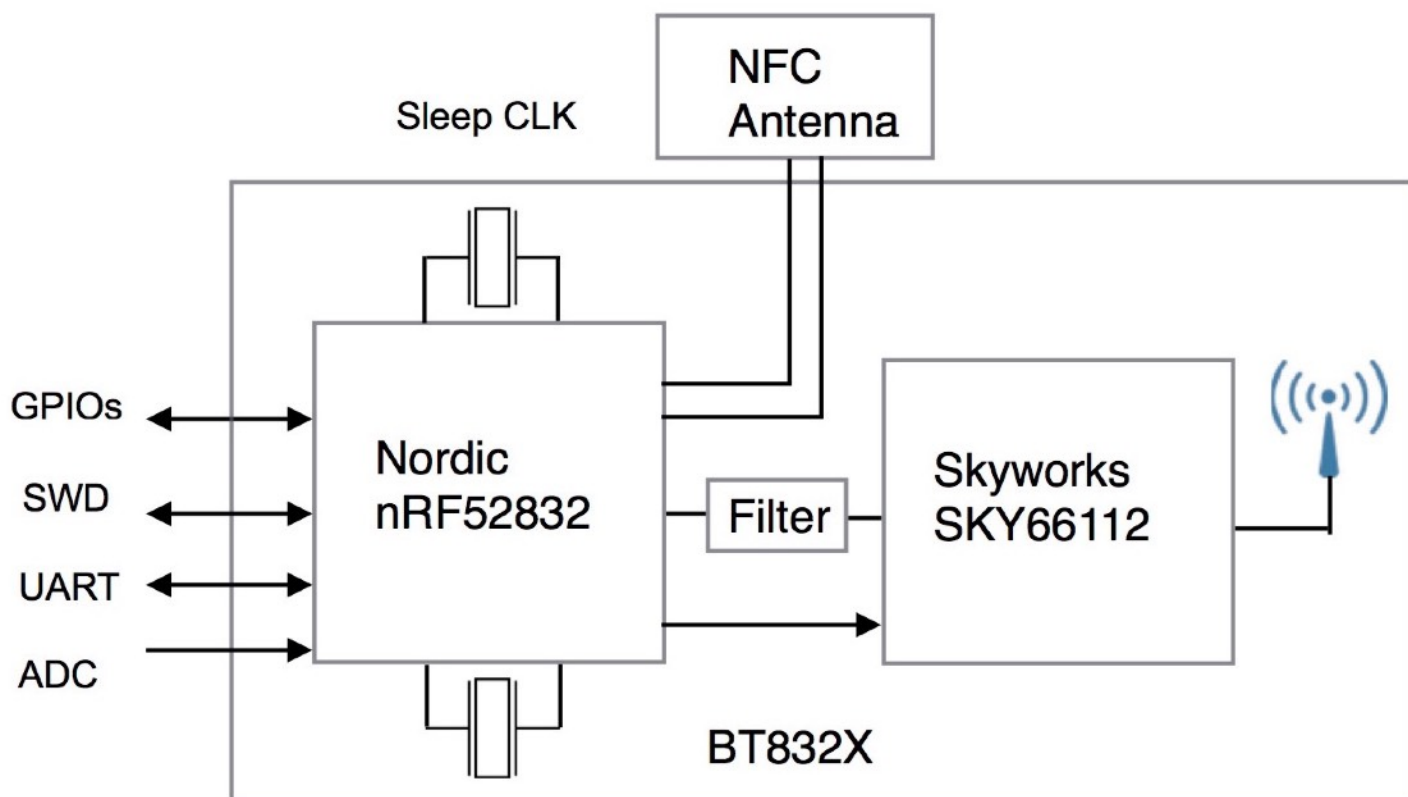

A high performance PCB trace antenna is integrated on BT832X. An u.FL connector on BT832XE provides connection to an external antenna. In this data sheets, both BT832X and BT832XE can be referred as BT832X.

BT832X

The followings are difference between BT832X and BT832 module

- Uses an nRF52832 QFAA with a Skyworks SKY66112 power amplifier
- Integrated PCB trace range antenna. Average range is 1170 meters. Minimum range and Maximum range around a circle is



Bluetooth 5 Modules with Amplifier, BT832X and BT832XE

1060 meters and 1320 meters, respectively.

- Higher power consumption
- 32.768 KHz sleep clock on board
- 29 GPIOs, 3 GPIOs are used to control SKY66112
- Size: 15x28x1.9mm



BT832XE with ANT060

ANT060 includes an antenna with SMA connector and an SMA to u.FL adaptor cable. The SMA connector side is panel-mountable.



The followings are difference between BT832XE and BT832 module

- Uses an nRF52832 QFAA with a Skyworks SKY66112 power amplifier
- An u.FL for external antenna. When ANT060 antenna is used, range is 1350 meters for all angles.
- Higher power consumption
- 32.768 KHz sleep clock on board
- 29 GPIOs, 3 GPIOs are used to control SKY66112
- Size: 15x28x1.9mm

Antennas ANT060 and ANT061

Two external antennas ANT060 and ANT061 are FCC and IC certified to be used with BT832XE. A photo of ANT060:



A photo of ANT061:



2. Codes Development Using Nordic Tools

Development tools by Nordic and other third party development tools recommended by Nordic should be used .

Easy, fast and safe code development

Nordic development environment for nRF52832 offers a clean separation between application code development and embedded protocol stacks. This means compile, link and run time dependencies with the embedded stack and associated debugging challenges are removed. The Bluetooth low energy and ANT stack is a pre-compiled binary, leaving application code to be compiled stand-alone. The embedded stack interface uses an asynchronous and event driven model removing the need for RTOS frameworks.

Over-The-Air DFU

The nRF52832 is supported by an Over-The-Air Device Firmware Upgrade (OTA DFU) feature. This allows for in the field updates of application software and SoftDevice.

SoftDevices

The Nordic protocol stacks are known as SoftDevices and complement the nRF52 Series SoCs. All nRF52 Series are programmable with software stacks from Nordic. This bring maximum flexibility to application development and allows the latest stack version to be programmed into the SoC.

SoftDevices available from Nordic:

S132: Bluetooth low energy concurrent central/peripheral/observer/broadcaster stack.

Development Tools

Nordic Semiconductor provides a complete range of hardware and software development tools for the nRF52 Series devices. nRF52 DK board is recommended for firmware development.

Nordic software development tools can be downloaded from the following webpage.

http://infocenter.nordicsemi.com/index.jsp?topic=/com.nordic.infocenter.nrf52/dita/nrf52/development/nrf52_dev_kit.html&cp=1_1

3. Product Overview

Brief description of nRF52832 SoC is provided. For full description of the SoC, please download from Nordic Semiconductor website.

<https://www.nordicsemi.com/eng/Products/Bluetooth-low-energy>

Block Diagram of nRF52832

The following is a block diagram of Nordic nRF52832 Bluetooth Low Energy (BLE) SoC.

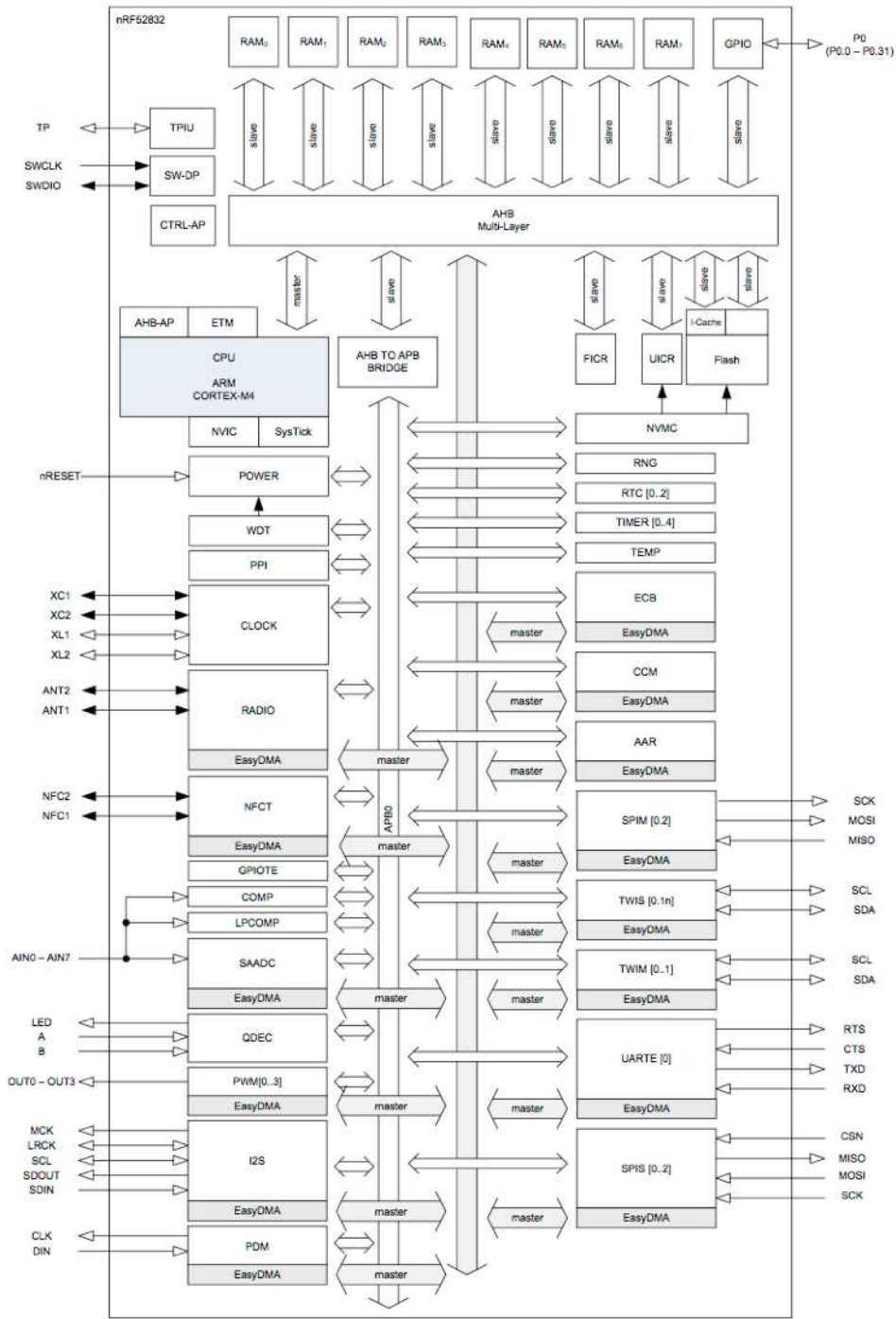

Bluetooth 5 Modules with Amplifier, BT832X and BT832XE

The 32 bit ARM Cortex M4F MCU with hardware supports for DSP instructions and floating point operations, code density and execution speed are higher than other Cortex M MCU. The Programmable Peripheral Interconnect (PPI) system provides a 20-channel bus for direct and autonomous system peripheral communication without CPU intervention. This brings predictable latency times for peripheral to peripheral interaction and power saving benefits associated with leaving CPU idle. The device has 2 global power modes ON/OFF, but all system blocks and peripherals have individual power management control which allows for an automatic switching RUN/IDLE for system blocks based only on those required/not required to achieve particular tasks.

The radio supports Bluetooth low energy and ANT. Output power is scalable from a maximum of +20dBm down to -4 dBm in 4dB steps.

The NFC block supports NFC-A tags with proximity detection and Wake-on-field from low power mode. The NFC enables Out-Of-Band (OOB) Bluetooth pairing of devices and thus greatly simplifying deployment.

Mechanical Drawings

The followings are mechanical drawings of BT832X. Two types of pins are available to meet different application requirements.

- 16 castellated pins for application needing limited number of IOs. SMT equipment is not required for soldering castellated pins.
- 24 LGA (Land Grid Array) pins to access 29 GPIOs of nRF52832 when needed. 3 GPIO pins are used to control SKY66112 power amplifier.

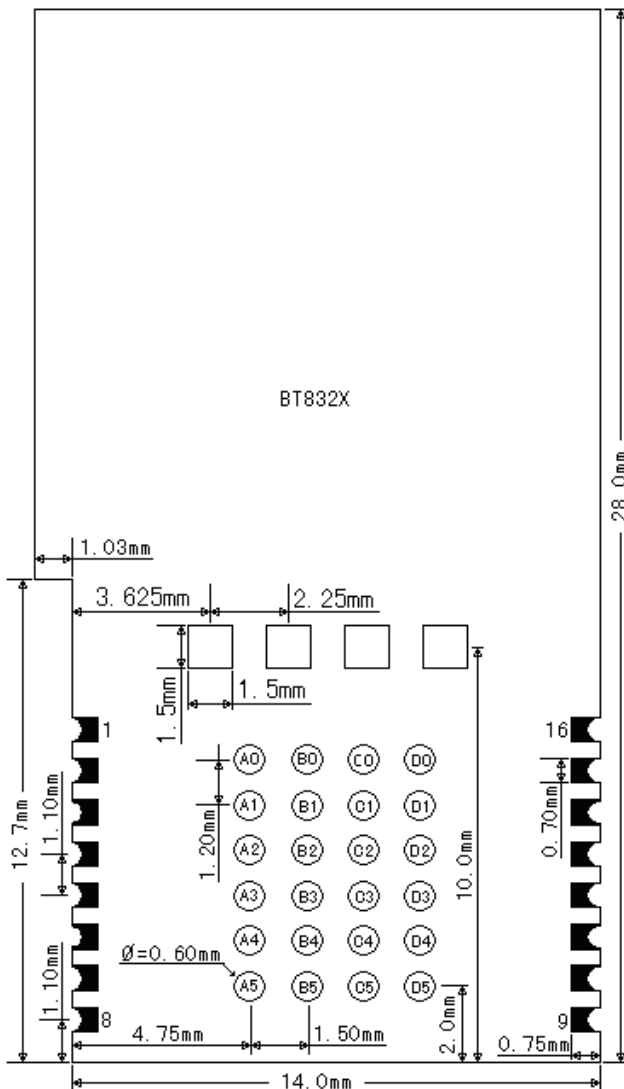

Pin Assignments of BT832X

The followings are BT832X pin assignment. Pin functions are in a table in next section. Please refer to Nordic nRF52832 Product Specifications for detailed descriptions and features supported.

http://infocenter.nordicsemi.com/pdf/nRF52832_PS_v1.1.pdf

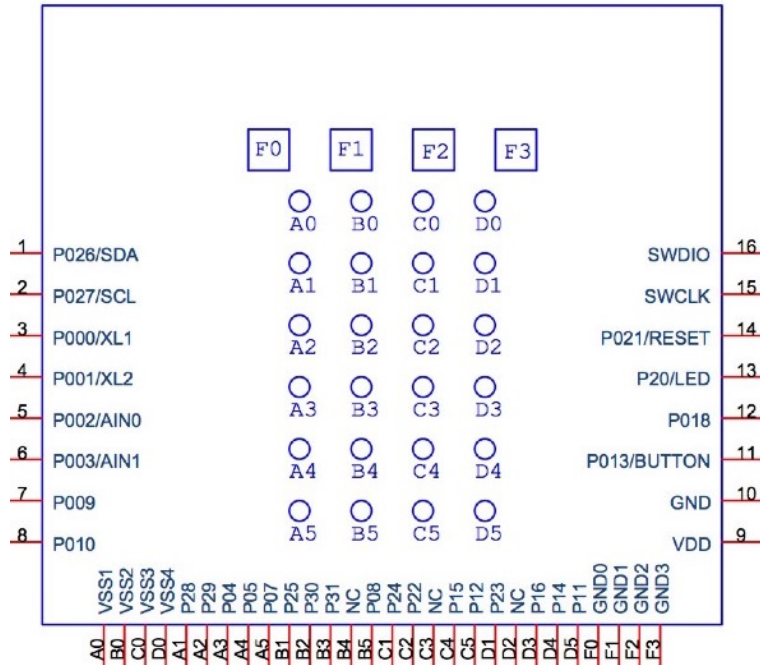

Pin Functions

BT832X		nRF52832		Descriptions
pin#	pin name	pin#	pin name	
1	P26/SDA	38	P0.26	GPIO, configured as I2C SDA on EV-BT832
2	P27/SCL	39	P0.27	GPIO, configured as I2C SCL on EV-BT832
3	NC	2	P0.00/XL1	32.768kHz crystal on module
4	NC	3	P0.01/XL2	32.768kHz crystal on module
5	P02/AIN0	4	P0.02/AIN0	GPIO, Analog input
6	P03/AIN1	5	P0.03/AIN1	GPIO, Analog input
7	P09/NFC1	11	P0.09/NFC1	GPIO, NFC antenna connection
8	P10/NFC2	12	P0.10/NFC2	GPIO, NFC antenna connection
9	VDD	13	VDD	DC supply 1.7V to 3.6V
10	GND	45	VSS	Ground
11	P13	16	P0.13	GPIO
12	P18	21	P0.18	GPIO
13	P20	23	P0.20	GPIO
14	P021/RESET	24	P0.21/RESET	GPIO, configurable as RESET pin
15	SWDCLK	25	SWDCLK	Serial Wire Debug clock input
16	SWDIO	26	SWDIO	Serial Wire Debug I/O
A0	GND	45	VSS	Ground
A1	P28	40	P0.28/AIN4	GPIO, Analog input
A2	P29	41	P0.29/AIN5	GPIO, Analog input
A3	P04	6	P0.04/AIN2	GPIO, Analog input
A4	P05	7	P0.05/AIN3	GPIO, Analog input
A5	P07	9	P0.07	GPIO
B0	GND	45	VSS	Ground
B1	P25	37	P0.25	GPIO
B2	P30	42	P0.30	GPIO
B3	P31	43	P0.31	GPIO
B4	NC	8	P0.06	No Connect, used for SKY66112 on module
B5	P08	10	P0.08	GPIO
C0	GND	45	VSS	Ground
C1	P24	29	P0.24	GPIO
C2	P22	27	P0.22	GPIO
C3	NC	20	P0.17	No Connect, used for SKY66112 on module
C4	P15	18	P0.15	GPIO
C5	P12	15	P0.12	GPIO
D0	GND	45	VSS	Ground
D1	P23	28	P0.23	GPIO
D2	NC	22	P0.19	No Connect, used for SKY66112 on module
D3	P16	19	P0.16	GPIO
D4	P14	17	P0.14	GPIO
D5	P11	14	P0.11	GPIO
F0	GND			Ground

F1	GND			Ground
F2	GND			Ground
F3	GND			Ground

Host PCB Layout Guidelines

For the best Bluetooth range performance, we recommend using library component extracted from EV BT840F V3 or newer Gerber files. It can be downloaded from <http://www.fanstel.com/download-document/>.

- There are 21 additional BT840F pins not used by BT832X. These pins are in solid dark color below.
- As much ground plane under BT832X, on top side of host PCB as possible. Use EV BT840F/EV BT832X Gerber files as an example.
- We recommend 4 or more layers for the host PCB. The top side shall be mostly ground. Signal routing shall be in the middle layers.

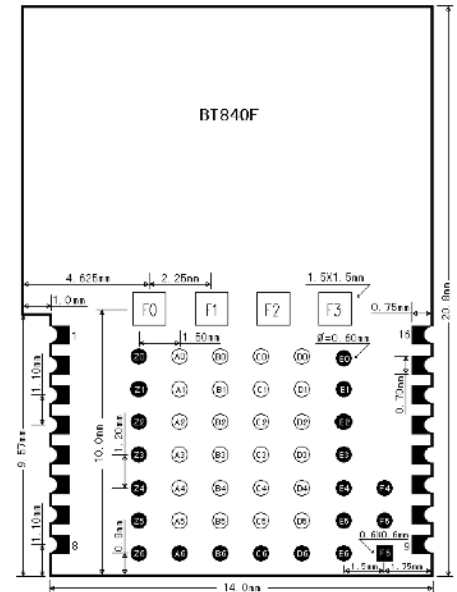

Bluetooth 5 Modules with Amplifier, BT832X and BT832XE

Mounting BT832X on the Host PCB

The following figure shows recommended mounting of BT832X module on the host PCB. These mounting guidelines are not applicable for BT832XE.

- For the best Bluetooth range performance, the antenna area of module shall extend 11.2 mm outside the edge of host PCB board, or 11.2 mm outside the edge of a ground plane.
- Except required for pin connection, ground plane to cover top layer of main board. We recommend multiple layers main board avoiding routing on the top layer.

For the best Bluetooth range performance, keep all external metal away from the antenna area.

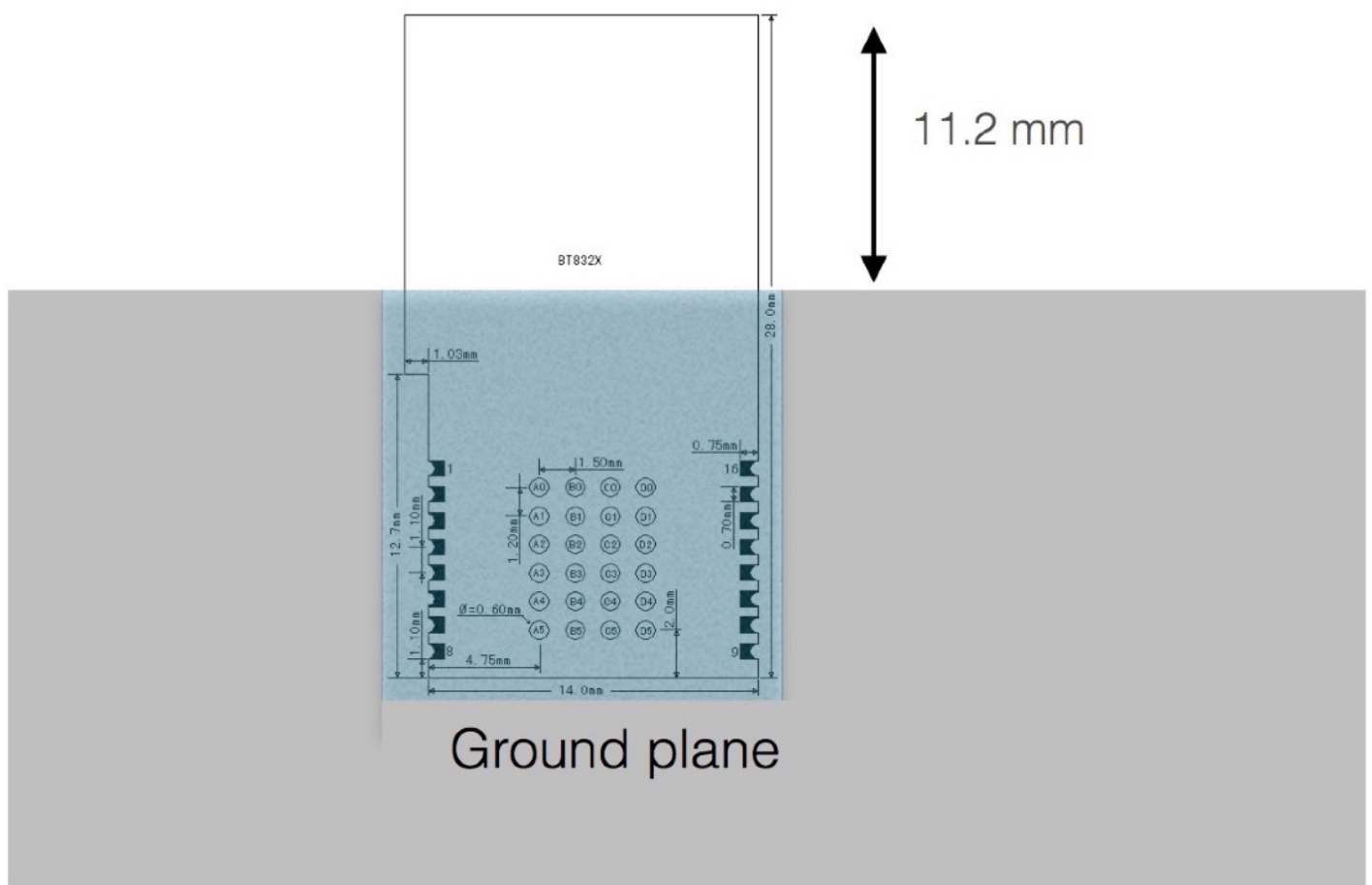

1. BT832X module extends 11.2 mm from edge or ground plane of the host PCB board
2. Except required for pin connection, ground plane on top layer of main board.

Control Skyworks Power Amplifier

BT832X uses SKYWORKS SKY66112-11 power amplifier. The connection diagram with control signal pins is below.

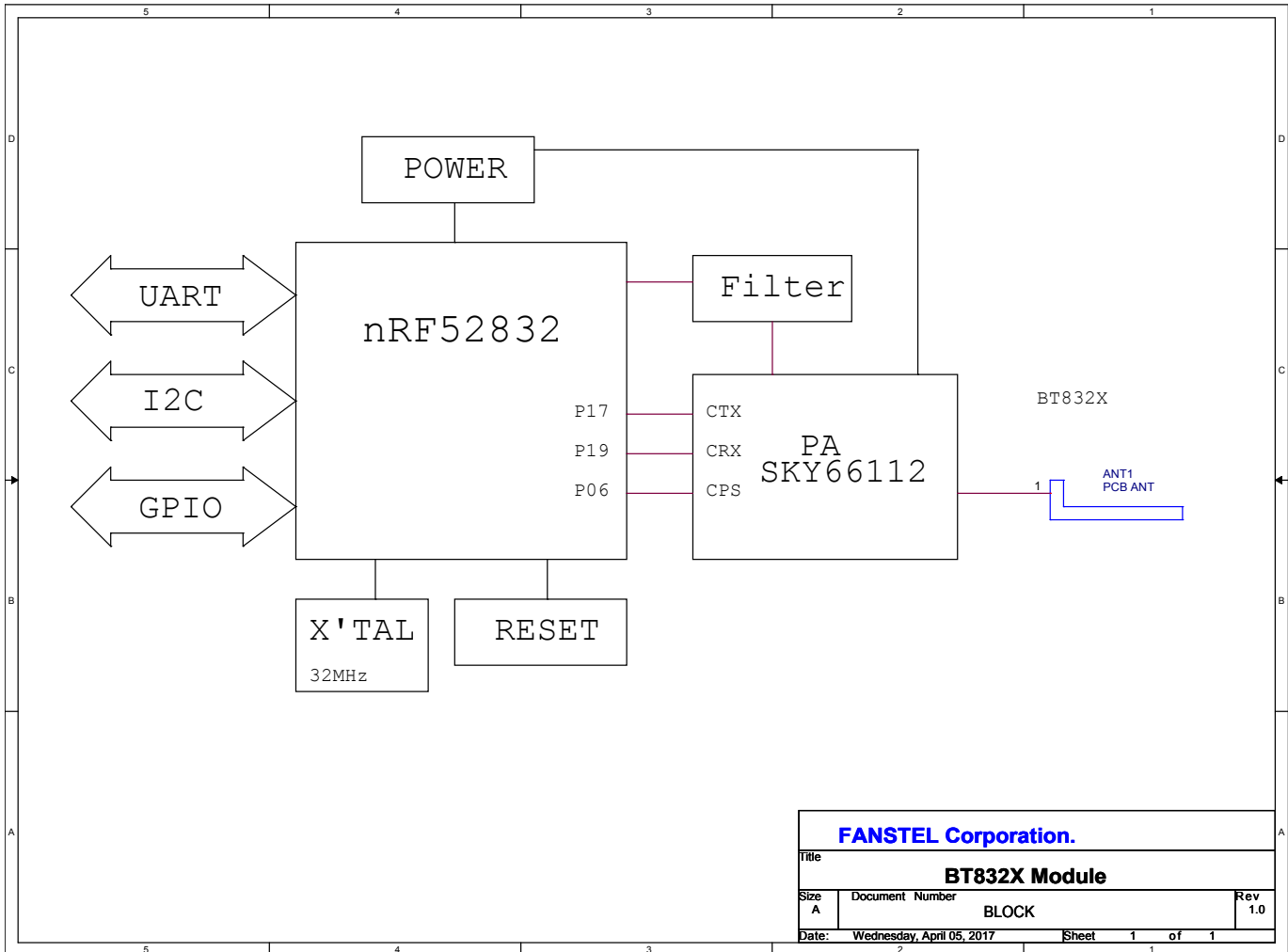

A firmware configuration example to control Skyworks SKY66112 power amplifier is below. This firmware file, SKY66112_PAconfig.txt can be downloaded from <http://www.fanstel.com/download-document/>.

```
//PCA10040.h
//set the clock
#define NRF_CLOCK_LFCLKSRC {source = NRF_CLOCK_LF_SRC_SYNTH, \
    .rc_ctiv = 0, \
    .rc_temp_ctiv = 0, \
    .xtal_accuracy = NRF_CLOCK_LF_XTAL_ACCURACY_250_PPM}
```

```
//main.c

//config the PA/LNA

#ifdef APP_PA_LAN

#define APP_PA_PIN          17
#define APP_LNA_PIN        19

#define APP_CPS_PIN          6

#define APP_AMP_PPI_CH_ID_SET  0
#define APP_AMP_PPI_CH_ID_CLR  1
#define APP_AMP_GPIOTE_CH_ID  0

static void pa_lna_setup(void)
{
    uint32_t err_code;
    nrf_gpio_cfg_output(APP_CPS_PIN);
        nrf_gpio_pin_clear(APP_CPS_PIN); //enable
        nrf_gpio_cfg_output(APP_PA_PIN);
        nrf_gpio_pin_clear(APP_PA_PIN); //
        nrf_gpio_cfg_output(APP_LNA_PIN);
        nrf_gpio_pin_clear(APP_LNA_PIN); //

    static ble_opt_t pa_lna_opts = {
        .common_opt = {
            .pa_lna = {

                .pa_cfg = {
                    .enable = 1,
                    .active_high = 1,
```

Bluetooth 5 Modules with Amplifier, BT832X and BT832XE

```
.gpio_pin = APP_PA_PIN
},

.lna_cfg = {
    .enable = 1,
    .active_high = 1,
    .gpio_pin = APP_LNA_PIN
},

.ppi_ch_id_set = APP_AMP_PPI_CH_ID_SET,
.ppi_ch_id_clr = APP_AMP_PPI_CH_ID_CLR,
.gpiote_ch_id = APP_AMP_GPIOTE_CH_ID
}
}
};
NRF_GPIO->DIRSET |= (1 << APP_PA_PIN) | (1 << APP_LNA_PIN);
err_code = sd_ble_opt_set(BLE_COMMON_OPT_PA_LNA, &pa_lna_opts);
APP_ERROR_CHECK(err_code);

}
#endif
```

4. AT Commands

AT command firmware is available for BT832X.

Brief description of AT commands

- Each command line consists of a prefix, a body and a terminator.
- All command lines begin with the prefix AT (ASCII 065, 084) or at (ASCII 097, 116).
- The body is a string of characters in the ASCII range 032-255. Control characters other than <CR> (carriage return; ASCII 013) and <BS> (back space; ASCII 008) in a command line are ignored.
- The terminator is <CR>.

Bluetooth 5 Modules with Amplifier, BT832X and BT832XE

- There is no distinction between upper-case and lower-case characters. A command line can have a maximum length of 80 characters. It is automatically discarded if the input is longer. Corrections are made
- AT command is case-insensitive, following /r/n for end code.
- The default baud rate is 9600 one stop bit and no parity

Command mode

When P0.03 of nRF52832 (pin 6 of BT832X) is pulled high, it is set to AT command mode. In AT command mode, the host processor communicates with the processor on BT832X.

Bluetooth 5 Modules with Amplifier, BT832X and BT832XE Ver 2.01 June 2018

<i>Command</i>	<i>Response</i>	<i>Parameter</i>	<i>example</i>
AT	OK or FAIL	none	AT/r/n OK/r/n
AT+RESET	OK or FAIL	none	AT+RESET/r/n OK/r/n
AT+VERSION?	+VERSION:<param> OK	Software version number	AT+VERSION?/r/n +VERSION140804 OK/r/n
AT+NAME?	+NAME:<param> OK	Device name	AT+NAME?/r/n +NAME:EZPro OK/r/n
AT+NAME=<param>	OK or FAIL	Device name	AT+NAME=Fanstel/r/n Or AT_Name="Fanstel"/r/n OK/r/n
AT+UART?	+UART:<param>,<param2>,<param3> > OK	Baud rate, Stop bit, Parity	AT+UART?/r/n +UART:115200,1,0 OK/r/n
AT+UART=<parm>	+UART:<parm>	Baud rate	AT+UART=115200/r/n +UART:115200,1,0 OK/r/n 1200 2400 4800 9600 default 19200 38400 57600 115200 230400 460800 921600 1000000
		Device	AT+ADDR?/r/n

Bluetooth 5 Modules with Amplifier, BT832X and BT832XE

Ver 2.01 June 2018

AT+ADDR?	+ADDR:<param> OK	MAC address	+ADDR:abb5:cd:604ace OK/r/n
AT+REGISTER	OK or FAIL	none	AT+REGISTER/r/n OK/r/n
AT+QUITREGISTER	OK or FAIL	none	AT+QUITREGISTER/r/n OK/r/n
AT+RX?	+Name:<parm> +UART:<parm> +ADDR:<parm>	none	AT+RX?/r/n +NAME:EZPro/r/n +UART:115200,1,1/r/n +ADDR: abb5:cd:604ace/r/n
AT+DEFAULT	OK or FAIL	none	AT+DEFAULT/r/n OK/r/n
AT_RFPW?	+RFPW:parm	+4~-8	AT+RFPW?/r/n +RFPW:-4 OK/r/n 0:+4 1:+0 default 2:-4 3:-8
AT_RFPW=<parm>	OK or FAIL	+4~-8	AT+RFPW= 1/r/n OK/r/n 0:+4 1:+0 2:-4 3:-8
AT+PIO=<param><param1>	OK or FAIL	P00-P05 1=High , 0=low	AT+PIO=05, 0\r/n OK/r/n
AT+PIS=<param><param1>	OK or FAIL	P00-P05 1=output, 0=input	AT+PIS=05, 1\r/n OK/r/n

Bluetooth 5 Modules with Amplifier, BT832X and BT832XE

Data Mode

When P0.03 of nRF52832 (pin 6 of BT832X) is pulled low, it is set to data mode. In data mode, BT832X provides transparent data transfer between the host processor and a remote device, for example, a smartphone.

Communicating with a PC

A quick and easy way to evaluate BT832X is to use a PC as the host processor. Connect the development board EV-BT832X to a PC with an USB cable. Then,

- Set S1, BT832X is set to command mode. PC will communicate with BT832X.
- Set switch S1 to the other position, BT832X is set to data mode. PC will communicate with a remote device through BT832X Bluetooth wireless connection.

Docklight is a testing, analysis and simulation tool for serial communication protocols (RS232, RS485/422 and others). It allows you to monitor the communication between two serial devices or to test the serial communication of a single device. Docklight significantly increases productivity in a broad range of industries, including automation and control, communications, automotive, equipment manufacturers, and embedded / consumer products. Docklight is easy to use and runs on almost any standard PC using Windows 10, Windows 8, Windows 7, Windows Vista or Windows XP operating system.

Docklight software can be downloaded from the following:

http://www.docklight.de/download_en.htm

5. Evaluation Boards and Reference Designs

Schematics and Gerber Files

Evaluation board schematics and Gerber files can be downloaded from

<http://www.fanstel.com/download-document/>

Evaluation board can be used as a reference design for using modules. EV BT840F V4 is designed for the BT840F soldering pads with 61 pins. When a BT832X is mounted on an EV BT840F, it becomes an EV BT832X. These 21 pins in solid dark color are not connected when a BT832X is mounted.

BT832X has the same soldering pad footprint as BT832 or BT832F. Library component for BT832 and BT840F can be used. For the Bluetooth range performance, BT840F library component shall be used for your BT832X design.

Evaluation Board EV BT832X Schematics

EV BT832X V4 evaluation board is developed for BT840F and BT832X. It can be used for BT832 and BT832F. Pins in solid color are used only for BT840F.

On EV BT832X, SW5 must be set to OFF and use on-board 32.768 KHz clock. Around U1 BT840 (832) red color pin functions are for BT840F and blue color pin functions are for BT832X.

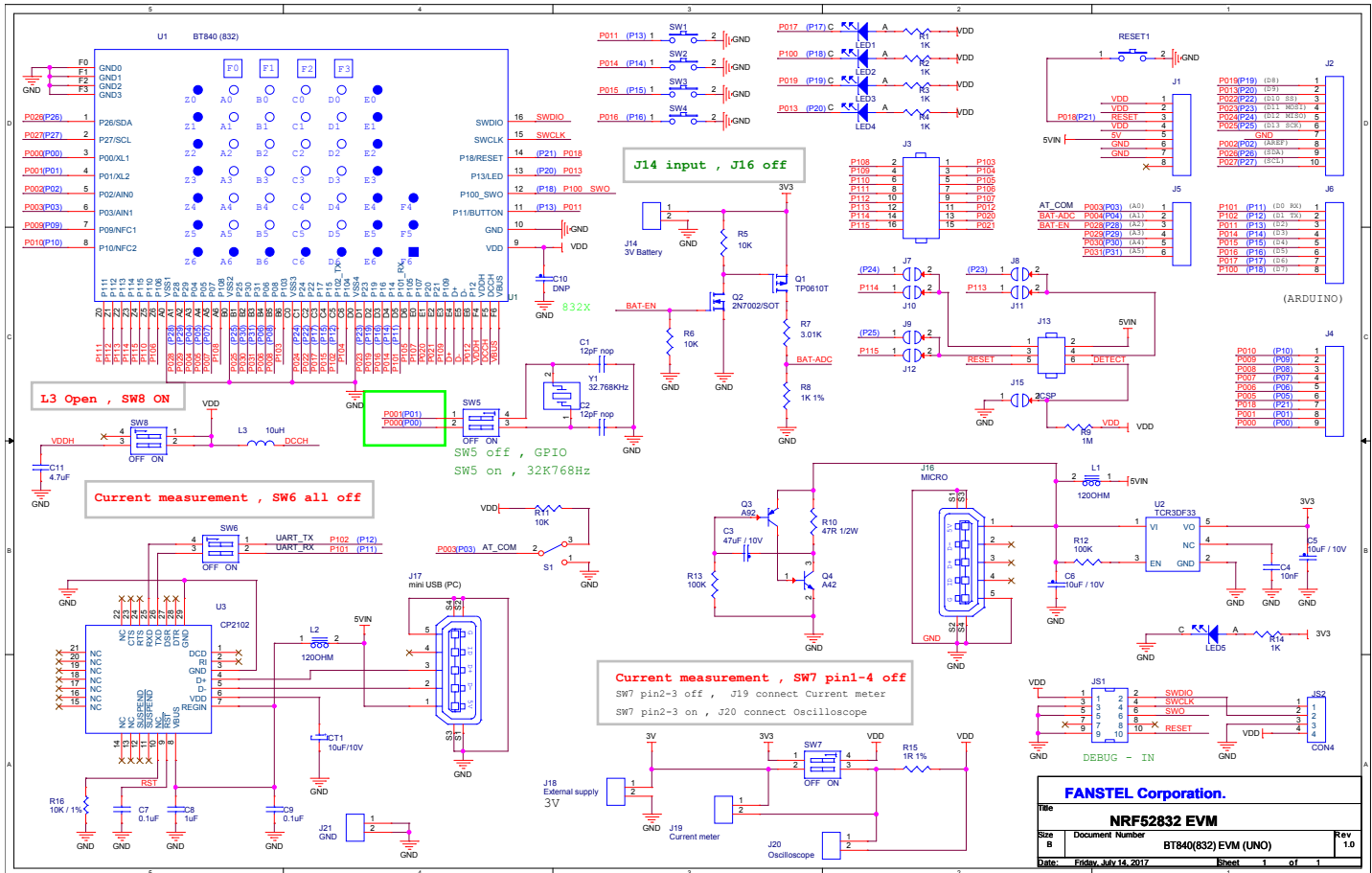

Additional feature enhancements for version V4 evaluation board:

1. It has the same foot print as Arduino Uno R3. Additional connectors are added for connection to extra GPIO pins of BlueNor modules.
2. EV BT832X is not an UNO R3 compatible board. You can use Nordic develop tools to develop firmware for many UNO R3 compatible shields.
3. SW5 must be set to OFF and use internal 32.768 kHz crystal or oscillator.
4. Portable smartphone charger can be used to power this board. The circuitry to the left of micro USB connector, J16 produces periodic load to prevent portable smartphone charger from shutting down.

Bluetooth 5 Modules with Amplifier, BT832X and BT832XE

5. Bluetooth Line of Sight Range Measurements

Test Conditions

We use evaluation boards EV BT832X and EV BT832XE for range measurement. A portable smartphone charger is used to power each board.

Bluetooth line of sight ranges are measured in Shen Zhen, China and Scottsdale, Arizona, USA. The Scottsdale test site is a better controlled environment. Except for dust blown up by wind or drive-by car, it is relatively interference free.

Each evaluation board is either loaded with Master firmware or Slave firmware. Each board sends a data packet out every second. When a valid data package is received, an LED toggles ON and OFF. Blinking LED indicates a valid data is received. We measure the maximum range between two boards that the LED is blinking.

The first evaluation board is mounted on a stick. The antenna is on vertical direction and at 2.1 meters above ground. The second evaluation board is mounted on a shorter stick carrier by a tester. After each measurement, the second evaluation board is rotated by about 30° for 12 total measurements.



Measurement results

- Ranges between two BT832X boards are average of 6 pairs of Master-Slave boards. BT832X antenna is not omni directional. Range at worst case angle is 1060 meters and at best case angle is 1320 meters. Average range is 1170 meters.
- BT832XE with external antenna ANT060 is omni-directional. Range is 1350 meters between two BT832XE boards for all directions.
- When BT832X is used with a BT832XE with ANT060, it is almost omni-directional. Ranges are between 1347 meters and 1350 meters for all angles.
- When tester lift the second stick, Bluetooth range is slightly longer.

Bluetooth 5 Modules with Amplifier, BT832X and BT832XE Ver 2.01 June 2018

- When BT832XE is used with a +12 dBi antenna (instead of ANT060 at +6 dBi), Bluetooth range increases from 1350 meters to 1352 meters.

	Range in meters between		
	BT832XE- BT832XE	BT832XE- BT832X	BT832X- BT832X
0	1350	1347	1305
30	1350	1350	1317
60	1350	1350	1322
90	1350	1350	1288
120	1350	1350	1142
150	1350	1350	1083
180	1350	1350	1075
210	1350	1347	1067
240	1350	1347	1092
270	1350	1350	1100
300	1350	1350	1117
330	1350	1347	1183
Average	1350	1349	1174

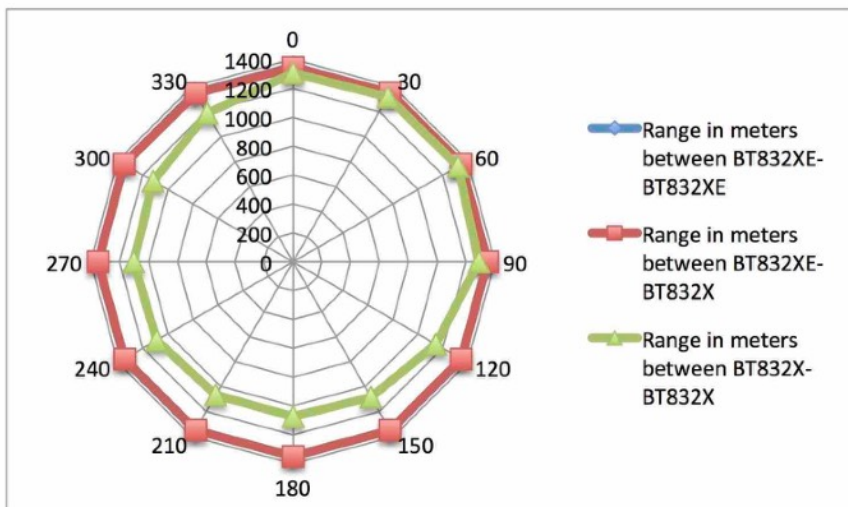

Conclusions and suggestions for deployment

- For the best range performance, antenna shall be vertically mounted.
- For omni-directional performance, at least one external antenna should be used in point to point deployment.
- In mesh network, an external antenna shall be used in each Relay node for omni directional performance.
- Mounting one or both antenna higher above ground and far away from physical objects can increase range.
- Our measurements are for clear line of sight. Range is reduced with plastic enclosure or with metal part nearby.
- External antenna ANA060 is panel mountable and with plastic cover.

6. Miscellaneous

Soldering Temperature-Time Profile for Re-Flow Soldering

Maximum number of cycles for re-flow is 2. No opposite side re-flow is allowed due to module weight.

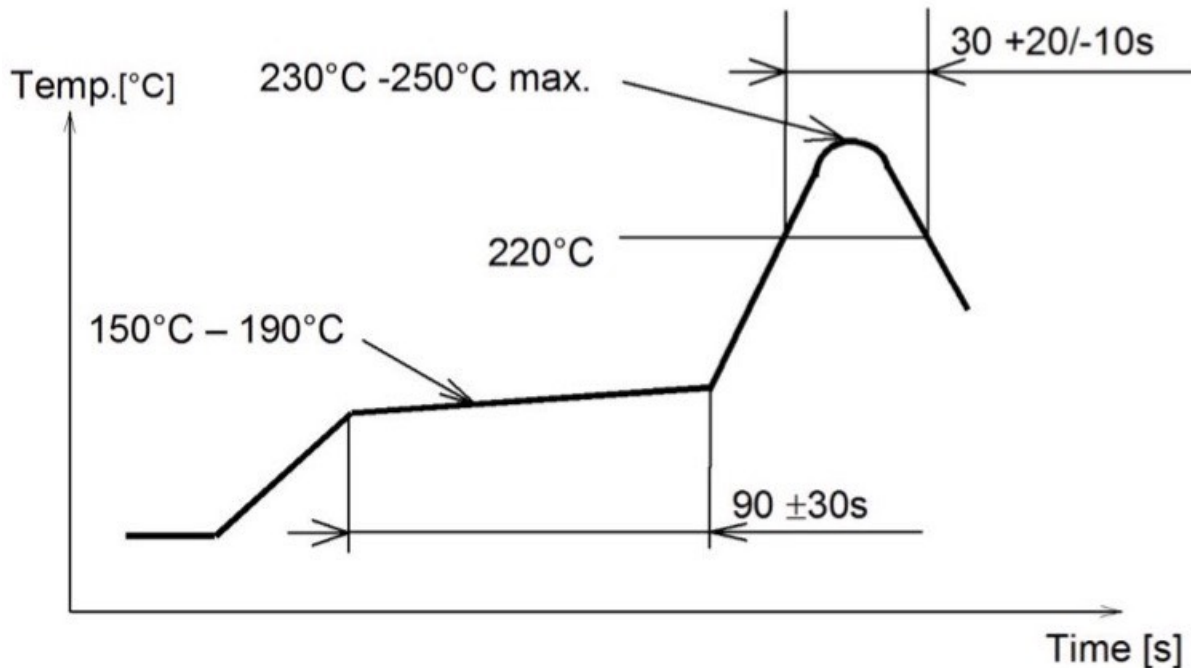

Cautions, Design Notes, and Installation Notes

Failure to follow the guidelines set forth in this document may result in degrading of the product's functions and damage to the product.

Design Notes

- (1) Follow the conditions written in this specification, especially the control signals of this module.
- (2) The supply voltage has to be free of AC ripple voltage (for example from a battery or a low noise regulator output). For noisy supply voltages, provide a decoupling circuit (for example a ferrite in series connection and a bypass capacitor to ground of at least 47uF directly at the module).
- (3) This product should not be mechanically stressed when installed.
- (4) Keep this product away from heat. Heat is the major cause of decreasing the life of these products.
- (5) Avoid assembly and use of the target equipment in conditions where the products' temperature may exceed the maximum tolerance.
- (6) The supply voltage should not be exceedingly high or reversed. It should not carry noise and/or spikes.

Bluetooth 5 Modules with Amplifier, BT832X and BT832XE

(7) this product away from other high frequency circuits.

Notes on Antenna and PCB Layout

(1) Don't use a module with internal antenna inside a metal case.

(2) For PCB layout:

- Avoid running any signal line below module whenever possible,
- No ground plane below antenna,
- If possible, cut-off the portion of main board PCB below antenna.

Installation Notes

(1) Reflow soldering is possible twice based on the time-temperature profile in this data sheets. Set up the temperature at the soldering portion of this product according to this reflow profile.

(2) Carefully position the products so that their heat will not burn into printed circuit boards or affect the other components that are susceptible to heat.

(3) Carefully locate these products so that their temperatures will not increase due to the effects of heat generated by neighboring components.

(4) If a vinyl-covered wire comes into contact with the products, then the cover will melt and generate toxic gas, damaging the insulation. Never allow contact between the cover and these products to occur.

(5) This product should not be mechanically stressed or vibrated when reflowed.

(6) If you want to repair your board by hand soldering, please keep the conditions of this chapter.

(7) Do not wash this product.

(8) Refer to the recommended pattern when designing a board.

(9) Pressing on parts of the metal cover or fastening objects to the metal will cause damage to the unit.

(10) For more details on LGA (Land Grid Array) soldering processes refer to the application note.

Usage Condition Notes

(1) Take measures to protect the unit against static electricity. If pulses or other transient loads (a large load applied in a short time) are applied to the products, check and evaluate their operation before assembly on the final products.

(2) Do not use dropped products.

(3) Do not touch, damage or soil the pins.

(4) Follow the recommended condition ratings about the power supply applied to this product.

(5) Electrode peeling strength: Do not add pressure of more than 4.9N when soldered on PCB

(6) Pressing on parts of the metal cover or fastening objects to the metal cover will cause damage.

Bluetooth 5 Modules with Amplifier, BT832X and BT832XE

(7) These products are intended for general purpose and standard use in general electronic equipment, such as home appliances, office equipment, information and communication equipment.

Storage Notes

(1) The module should not be stressed mechanically during storage.

(2) Do not store these products in the following conditions or the performance characteristics of the product, such as RF performance will be adversely affected:

- Storage in salty air or in an environment with a high concentration of corrosive gas.
- Storage in direct sunlight
- Storage in an environment where the temperature may be outside the range specified.
- Storage of the products for more than one year after the date of delivery storage period.

(3) Keep this product away from water, poisonous gas and corrosive gas.

(4) This product should not be stressed or shocked when transported.

(5) Follow the specification when stacking packed crates (max. 10).

Safety Conditions

These specifications are intended to preserve the quality assurance of products and individual components. Before use, check and evaluate the operation when mounted on your products. Abide by these specifications, without deviation when using the products. These products may short-circuit. If electrical shocks, smoke, fire, and/or accidents involving human life are anticipated when a short circuit occurs, then provide the following failsafe functions, as a minimum.

(1) Ensure the safety of the whole system by installing a protection circuit and a protection device.

(2) Ensure the safety of the whole system by installing a redundant circuit or another system to prevent a dual fault causing an unsafe status.

Other Cautions

(1) This specification sheet is copyrighted. Reproduction of this data sheet is permissible only if reproduction is without alteration and is accompanied by all associated warranties, conditions, limitations, and notices.

(2) Do not use the products for other purposes than those listed.

(3) Be sure to provide an appropriate failsafe function on your product to prevent an additional damage that may be caused by the abnormal function or the failure of the product.

(4) This product has been manufactured without any ozone chemical controlled under the Montreal Protocol.

(5) These products are not intended for other uses, other than under the special conditions shown below. Before using these products under such special conditions, check their performance and reliability under the said special conditions carefully to determine whether or not they can be used in such a manner.