



Chipsmall Limited consists of a professional team with an average of over 10 year of expertise in the distribution of electronic components. Based in Hongkong, we have already established firm and mutual-benefit business relationships with customers from,Europe,America and south Asia,supplying obsolete and hard-to-find components to meet their specific needs.

With the principle of “Quality Parts,Customers Priority,Honest Operation,and Considerate Service”,our business mainly focus on the distribution of electronic components. Line cards we deal with include Microchip,ALPS,ROHM,Xilinx,Pulse,ON,Everlight and Freescale. Main products comprise IC,Modules,Potentiometer,IC Socket,Relay,Connector.Our parts cover such applications as commercial,industrial, and automotives areas.

We are looking forward to setting up business relationship with you and hope to provide you with the best service and solution. Let us make a better world for our industry!



Contact us

Tel: +86-755-8981 8866 Fax: +86-755-8427 6832

Email & Skype: info@chipsmall.com Web: www.chipsmall.com

Address: A1208, Overseas Decoration Building, #122 Zhenhua RD., Futian, Shenzhen, China



Datasheet

BT85x Series

Bluetooth v4.2 Dual-Mode USB HCI Module

Version 1.1

CONTENTS

1	Scope	4
2	Operational Description	4
3	Block Diagram and Descriptions	5
4	Specifications	6
5	Pin Definitions	7
6	DC Electrical Characteristics	8
7	RF Characteristics	9
8	Interface	10
8.1.	Global Coexistence Interface.....	10
8.2.	USB Interface	10
8.3.	PCM Interface	10
8.4.	I ² S Interface	16
9	Antenna Performance	18
10	Mechanical Dimensions and Land Pattern	20
11	Implementation Note	21
11.1.	PCB Layout on Host PCB	21
12	Application Note for Surface Mount Modules	23
12.1.	Introduction.....	23
12.2.	Shipping	23
12.3.	Reflow Parameters	25
13	Japan (MIC) Regulatory	26
14	FCC Regulatory	26
14.1.	Documentation Requirements	27
15	Industry Canada Regulatory	28
16	European Union Regulatory	30
17	Ordering Information	31
18	Bluetooth SIG Approvals	31
19	Additional Assistance	33

1 SCOPE

This document describes key hardware aspects of the Laird BT85x Bluetooth HCI module and Adapter. This document is mainly intended to assist device manufacturers and related parties with the integration of this module into their host devices. Data in this document are drawn from several sources including data sheets for the Cypress CYW20704A2.

Because the BT850-Sx is currently in development stage, this document is preliminary and the information in this document is subject to change. Please contact Laird Technologies or visit the [product page](#) on the Laird website to obtain the most recent version of this document.



BT850-SA



BT850-ST



BT851

2 OPERATIONAL DESCRIPTION

The BT85x series of USB HCI modules and Adapter leverage the Cypress CYW20704 A2 chipset to provide exceptionally low power consumption with outstanding range for OEMs needing both Classic Bluetooth and Bluetooth Low Energy support. The Bluetooth v4.2 core specification shortens your development time and provides enhanced throughput, security and privacy.

The BT850 modules are ideal when designers need both performance and minimum size. For maximum flexibility in integration, they support a host USB interface, I²S and PCM audio interfaces, GPIO, and Cypress'GCI coexistence (2-wire). The modules provide excellent RF performance and identical footprint options for integrated antenna or an external antenna via a trace pin.

These modules present a Bluetooth standard HCI interface with native support for Windows, Linux and Android Bluetooth software stacks for operating system backed devices. The BT851 Pluggable USB Adapter with inbuilt Bluetooth stack simply plugs into any Windows, Android or Linux device via external USB connection.

Additionally, Laird has partnered with [Searan](#) for support of their ultra small, flexible 'dotstack' platform for embedded Cortex M3 and M4 implementations.

Features and Benefits

- Bluetooth v4.2 - Dual Mode (Classic Bluetooth and BLE)
- Compact footprint
- 2-wire Cypress Global Coexistence Interface (GCI)
- High antenna radiation gain and efficiency
- Good interference rejection for multi-com system (GSM/WCDMA)
- Class 1 output – 8 dBm
- USB, I²S, and PCM
- Industrial temperature range
- 512 k EEPROM support
- Bluetooth Controller subsystem
- FCC, IC, CE, RCM and Giteki approvals

Application Areas

- Medical devices
- ePOS terminals
- Barcode scanners
- Industrial cable replacement
- IoT Platforms Automotive Diagnostic Equipment
- Personal Digital Assistants (PDA)

3 BLOCK DIAGRAM AND DESCRIPTIONS

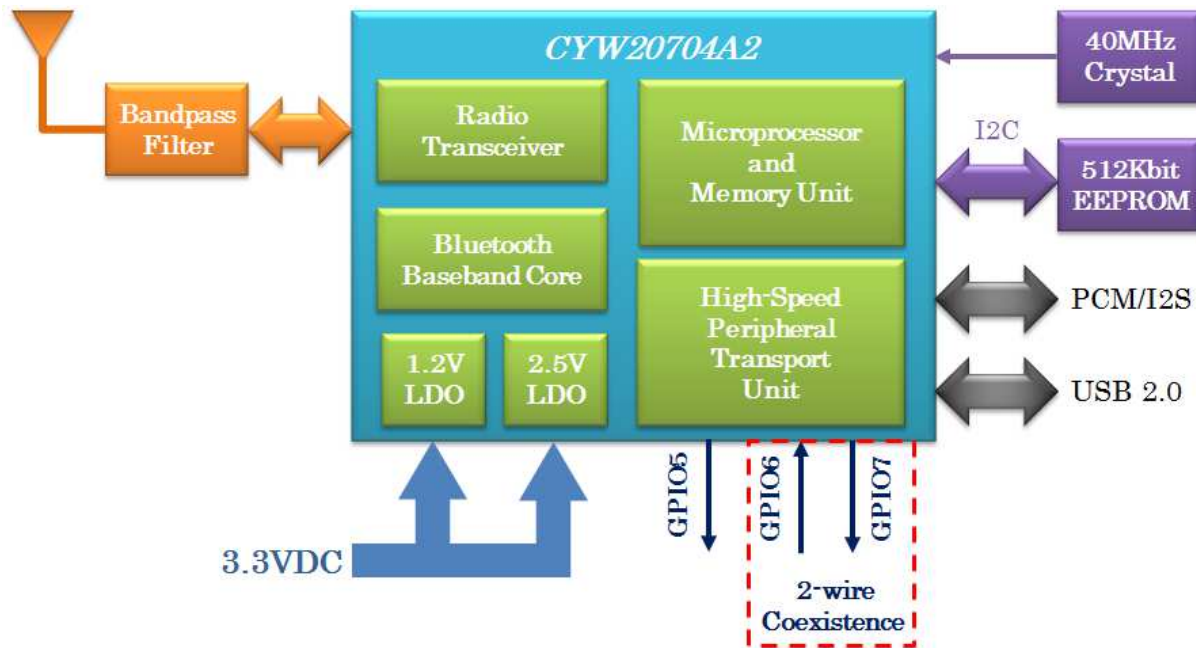

Figure 1: BT850 module block diagram

Table 1: Block diagram descriptions

CYW20704A2 (Main chip)	The BT85x is based on CYW20704A2 dual mode chip. The chip is a single-chip radio with on-chip LDO regulators and baseband IC for Bluetooth 2.4 GHz systems including EDR to 3 Mbps. Dedicated signal and baseband processing is included for full Bluetooth operation. The chip provides I ² S/PCM and USB interfaces. There are two general purpose I/Os be configured for proprietary of Cypress GCI used and a general purpose I/O can be configured for scan/inquire/paging/data traffic of indicator. These three I/O pins are controlled by firmware.
Antenna	BT850-SA & BT851 – The antenna is a ceramic monopole chip antenna. BT850-ST – Trace Pad provision for use with a range of certified External Antennas
Band Pass Filter	The band pass filter filters the out-of-band emissions from the transmitter to meet the specific regulations for type approvals of various countries.
EEPROM	There are 512 k bits EEPROM embedded on the BT85x which can be used to store parameters, such as BD_ADDR, USB enumeration information, maximum TX power, PCM configuration, USB product ID, USB vendor ID, and USB product description.
Crystal	The embedded 40 MHz crystal is used for generating the clock for the entire module.

4 SPECIFICATIONS

Table 2: BT850 specifications

Categories	Feature	Implementation
Wireless Specification	Bluetooth®	V4.2 Dual Mode – BR / EDR / LE
	Frequency	2.402 - 2.480 GHz
	Maximum Transmit Power	Class 1 +8 dBm from antenna
	Receive Sensitivity	-94 dBm
	Range	Circa 100 meters
	Data Rates	Up to 3 Mbps (over-the-air)
Host Interface	USB	Full speed USB 2.0
	GPIO	3.3V for all general purpose I/Os
Operational Mode	HCI	Host Controller Interface over USB
EEPROM	2-wire	512 K bits
Coexistence	802.11 (Wi-Fi)	2-Wire Cypress Global Coexistence Interface (GCI)
Supply Voltage	Supply	3.0V - 3.6V
Power Consumption	Current	Idle Mode ~8 mA
		File Transfer ~43 mA
Antenna Options	Internal	Multilayer ceramic antenna
	External	Trace Pad
Physical (Width x Length x Height)	Dimensions	8.5 x 12.85 x 2.2 mm (BT850-SA)
		8.5 x 12.85 x 1.9 mm (BT850-ST)
		16 x 43 x 11 (BT851 – USB dongle)
Environmental	Operating	-30° C to +85° C
	Storage	-40° C to +85° C
Miscellaneous	Lead Free	Lead-free and RoHS-compliant
	Warranty	One-year warranty
Approvals	Bluetooth®	Controller Subsystem Approved
	FCC/IC/CE/RCM/Giteki	All BT85x series

5 PIN DEFINITIONS

Table 3: BT850 pin definitions

Pin No.	Pin Name	I/O	Supply Domain	Description	If Unused
1	NC				NC
2	NC				
3	GND	GND		Ground	GND
4	USB_D+	Bidirectional	3V3	USB data plus	N/A
5	USB_D-	Bidirectional	3V3	USB data negative	N/A
6	GND	GND		Ground	GND
7	NC				NC
8	RESET	Input	3v3	Active-low reset input	N/A
9	3v3	Input	3v3	Module main DC power supply, Input to internal 1.2V and 2.5V LDO	N/A
10	NC				NC
11	GND	GND		Ground	GND
12	GND	GND		Ground	GND
13	GND	GND		Ground	GND
14	GND	GND		Ground	GND
15	GND	GND		Ground	GND
16	GND	GND		Ground	GND
17	RF			BT850-ST RF signal output (50Ω) BT850-SA No connection	
18	GND	GND		Ground	GND
19	I2S_WS/PCM_SYNC	Bidirectional	3V3	PCM sync/I2S word select	NC
20	I2S_CLK/PCM_CLK	Bidirectional	3V3	PCM/I2S clock	NC
21	I2S_DI/PCM_IN	Bidirectional	3V3	PCM/I2S data input	NC
22	I2S_OUT/PCM_OUT	Bidirectional	3V3	PCM/I2S data output	NC
23	NC				NC
24	GND	GND		Ground	GND
25	BT_SECI_IN	Input	3V3	Coexistence data input	NC
26	BT_SECI_OUT	Output	3V3	Coexistence data output	NC
27	NC				NC
28	GPIO_5	Bidirectional	3V3	Programmable input/output line	NC

Pin Definition Note 1:

The GPIO_5 is controlled by the default firmware for the status of BT850 indications.

6 DC ELECTRICAL CHARACTERISTICS

Table 4: Absolute Maximum Rating

Rating	Min	Max	Unit
Storage temperature	-40	+150	°C
Operating Temperature	-30	+85	°C
ESD Contact Discharge	-4	+4	KV
ESD Air Discharge	-8	+8	KV
Moisture Sensitivity Level	3	-	-
3V3 Input	3.0	3.6	V

Table 5: Recommended operating conditions

Rating	Min	Max	Unit
Storage temperature	-40	+150	°C
Operating Temperature	-30	+85	°C
3V3 Input	3.0	3.6	V

Table 6: Digital I/O characteristics

Normal Operation	Min	Typ.	Max	Unit
V _{IL} Input Low Voltage (VDDO* = 3V3)	-	-	0.8	V
V _{IH} Input High Voltage (VDDO* = 3V3)	2.0	-	-	V
V _{OL} Output Low Voltage	-	-	0.4	V
V _{OH} Output High Voltage	3V3-0.4	-	-	V
I _{IL} Input Low Current	-	-	1.0	µA
I _{IH} Input High Current	-	-	1.0	µA
I _{OL} Output Low Current (VDDO* = 3V3, V _{OL} = 0.4V)	-	-	2.0	mA
I _{OH} Output Low Current (VDDO* = 3V3, V _{OH} = 2.9V)	-	-	2.0	mA
C _{IN} Input Capacitance	-	-	0.4	pF

*: The VDDO is denoted the digital I/O voltage and it's depended on the Pin9 (3V3) input of module.

Table 7: Current consumption

Normal Operation	Peak (8 dBm)	Unit
Idle	8	mA
Inquiry	23	mA
File Transfer	43	mA
BLE Connected (Master)	26	mA
BLE Scan (Master)	26	mA
BLE File Transfer	27	mA

7 RF CHARACTERISTICS

Table 8: BDR/EDR/LE transmitter characteristics (Input = 3V3 @ 25 °C)

Parameter	Min	Typ.	Max	BT. Spec.	Unit	
Classic BT (BDR) - GFSK Maximum RF Transmit Power	6	8	10	20	dBm	
Classic BT - EDR Maximum RF Transmit Power	2	4	6	20	dBm	
BLE Maximum RF Transmit Power	6	8	10	20	dBm	
RF power variation over temperature range	-	2.0	-	-	dB	
RF power variation over BT band	-	2	-	-	dB	
RF power control step	2	4	8	-	dB	
Initial Carrier Frequency Tolerance	-	10	-	±75	kHz	
BLE Frequency Accuracy	-	10	-	±150	kHz	
20 dB Bandwidth	-	920	-	1000	kHz	
In-Band Spurious Emissions	1.0 MHz < M-N < 1.5 MHz	-	-	-39	-26	dBc
	1.5 MHz < M-N < 2.5 MHz	-	-	-39	-20	dBm
	M-N ≥ 2.5 MHz	-	-	-47	-40	dBm
BLE In-Band Emission	$f_{TX} \pm 2$ MHz	-	-	-48	-20	dBm
	$f_{TX} \pm [3 + n]$ MHz	-	-	-47	-30	dBm
Drift rate	-	10	-	+/-25	kHz	
$\Delta F1_{Avg}$	-	152	-	140<>175	kHz	
$\Delta F2_{Max}$	100	-	-	99.9	%	
$\Delta F2_{Avg} / \Delta F1_{Avg}$	-	1.0	-	≥ 0.8		
BLE $\Delta F1_{Avg}$	-	245	-	225<>275	kHz	
BLE $\Delta F2_{Max}$	100	-	-	99.9	%	
BLE $\Delta F2_{Avg} / \Delta F1_{Avg}$	-	1.0	-	≥ 0.8		

Table 9: BDR/EDR/LE receiver sensitivity (Input = 3V3 @ 25 °C)

Parameter	Conditions	Min	Typ.	Max	BT. Spec.	Unit
Sensitivity	GFSK, 0.1% BER, 1 Mbps	-	-90	-	-70	dBm
	$\pi/4$ -DQPSK, 0.01% BER, 2 Mbps	-	-94	-	-70	dBm
	8-DPSK, 0.01% BER, 3 Mbps	-	-87	-	-70	dBm
	BLE GFSK, 30.8% PER, 1 Mbps	-	-94	-	-70	dBm
Sensitivity variation	All Modulations (Over BT band)	-	2	-	-	dB

8 INTERFACE

8.1. Global Coexistence Interface

The BT850-Sx supports the proprietary Cypress Global Coexistence Interface (GCI) which is a two-wire interface.

The following key features are associated with the interface:

- Enhanced coexistence data can be exchanged over GCI_SECI_IN and GCI_SECI_OUT a two-wire interface, one serial input (GCI_SECI_IN), and one serial output (GCI_SECI_OUT). The both pins are controlled by the configuration file that is stored in EEPROM from the host.
- It supports generic UART communication between WLAN and Bluetooth devices.
- To conserve power, it is disabled when inactive.
- It supports automatic resynchronization upon waking from sleep mode.
- It supports a baud rate of up to 4 Mbps.

Table 10 shows the two-wire BT coexistence interface assignments.

Table 10: BDR/EDR/LE receiver sensitivity (Input = 3V3 @ 25 °C)

Coexistence Signal Name	Signal Assignment
BT_SECI_IN	GPIO_6
BT_SECI_OUT	GPIO_7

8.2. USB Interface

BT85x has a full-speed (12 Mbps) USB interface for communicating with other compatible digital devices. The USB interface on the BT85x acts as a USB peripheral, responding to requests from a master host controller.

BT85x supports the Universal Serial Bus Specification (USB v2.0 Specification) and USB Battery Charging Specification, available from <http://www.usb.org>. For more information on how to integrate the USB interface on BT85xd, see Figure 14 located in the following section: [USB Dongle Design Example Using BT850](#).

The following USB interface features are supported:

- USB Protocol, revision 2.0, full-speed compliant with LPM support (up to 12 Mbps)
- Bluetooth HCI
- Integrated detach resistor
- USB termination when interface is not in use
- Internal modules, certification, and non-specification compliant operation

8.3. PCM Interface

The BT850-Sx supports two independent PCM interfaces that share the pins with I²S interfaces. The PCM interface on the BT850-Sx can connect to linear PCM Codec devices in master or slave mode. In master mode, the BT850-Sx generates the PCM_CLK and PCM_SYNC signals; in slave mode, these signals are provided by another master on the PCM interface and are inputs to the BT850-Sx.

The configuration of the PCM interface may be adjusted by the host using vendor-specific HCI commands.

For additional information, refer to the DVK-BT85x-Sx User Guide available from the [BT85x product page](#) of the Laird website.

8.3.1. Slot Mapping

The BT850-Sx supports up to three simultaneous full-duplex SCO or eSCO channels through the PCM interface. These three channels are time-multiplexed onto the single PCM interface by using a time-slotting scheme where the 8 kHz or 16 kHz audio sample interval is divided into as many as 16 slots. The number of slots is dependent on the selected interface rate of 128 kHz, 512 kHz, or 1024 kHz. The corresponding number of slots for these interface rate is 1, 2, 4, 8, and 16, respectively. Transmit and receive PCM data from an SCO channel is always mapped to the same slot. The PCM data output driver tristates its output on unused slots to allow other devices to share the same PCM interface signals. The data output driver tristates its output after the falling edge of the PCM clock during the last bit of the slot.

8.3.2. Frame Synchronization

The BT850-Sx supports both short- and long-frame synchronization in both master and slave modes. In short-frame synchronization mode, the frame synchronization signals an active-high pulse at the audio frame rate that is a single-bit period in width and is synchronized to the rising edge of the bit clock. The PCM slave looks for a high on the falling edge of the bit clock and expects the first bit of the first slot to start at the next rising edge of the clock.

Figure 2 and Table 11 shows PCM Timing Diagram and Specifications for the master mode of short-frame.

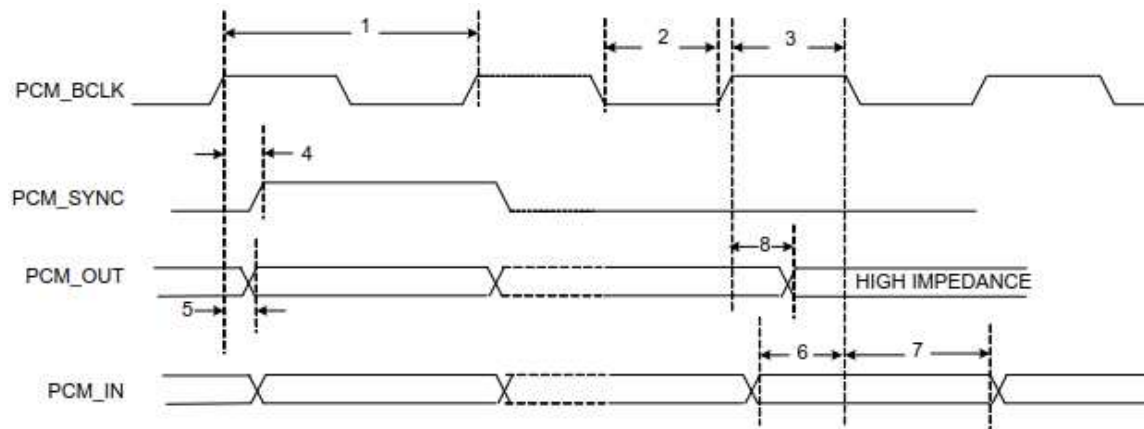

Figure 2: PCM timing diagram (Short-Frame Sync, Master Mode)

Table 11: PCM Interface timing specifications (Short-Frame Sync, Master Mode)

Ref No.	Characteristics	Minimum	Typical	Maximum	Unit
1	PCM bit clock frequency	-	-	12	MHz
2	PCM bit clock LOW	41	-	-	ns
3	PCM bit clock HIGH	41	-	-	ns
4	PCM_SYNC setup	0	-	25	ns
5	PCM_OUT delay	0	-	25	ns
6	PCM_IN setup	8	-	-	ns
7	PCM_IN hold	8	-	-	ns
8	Delay from rising edge of PCM_BCLK during last bit period to PCM_OUT becoming high impedance	0	-	25	ns

Figure 3 and Table 12 shows PCM Timing Diagram and Specifications for the slave mode of short-frame.

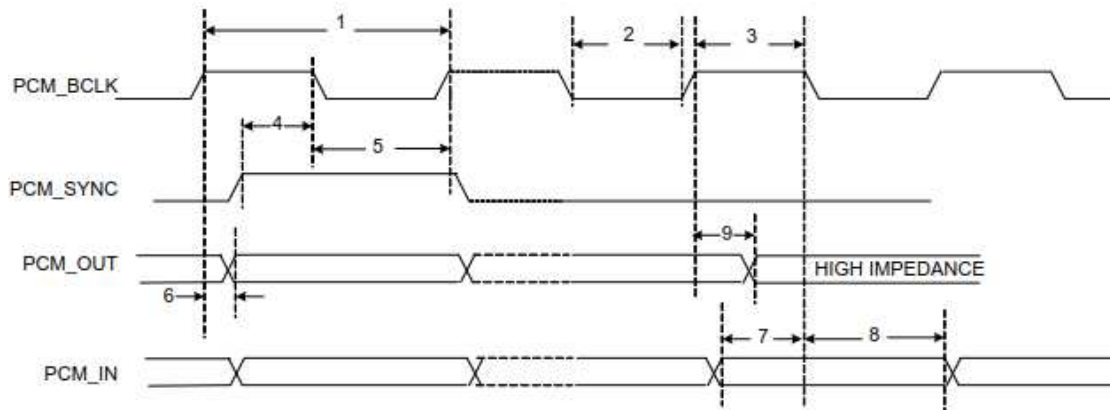

Figure 3: PCM timing diagram (Short-Frame Sync, Slave Mode)

Table 12: PCM Interface timing specifications (Short-Frame Sync, Slave Mode)

Ref No.	Characteristics	Minimum	Typical	Maximum	Unit
1	PCM bit clock frequency	-	-	12	MHz
2	PCM bit clock LOW	41	-	-	ns
3	PCM bit clock HIGH	41	-	-	ns
4	PCM_SYNC setup	8	-	-	ns
5	PCM_SYNC hold	8	-	-	ns
6	PCM_OUT delay	0	-	25	ns
7	PCM_IN setup	8	-	-	ns
8	PCM_IN hold	8	-	-	ns
9	Delay from rising edge of PCM_BCLK during last bit period to PCM_OUT becoming high impedance	0	-	25	ns

In long-frame synchronization mode, the frame synchronization signal is again an active-high pulse at the audio frame rate; however, the duration is three bit periods and the pulse starts coincident with the first bit of the first slot.

Figure 4 and Table 13 shows PCM Timing Diagram and Specifications for the master mode of long-frame.

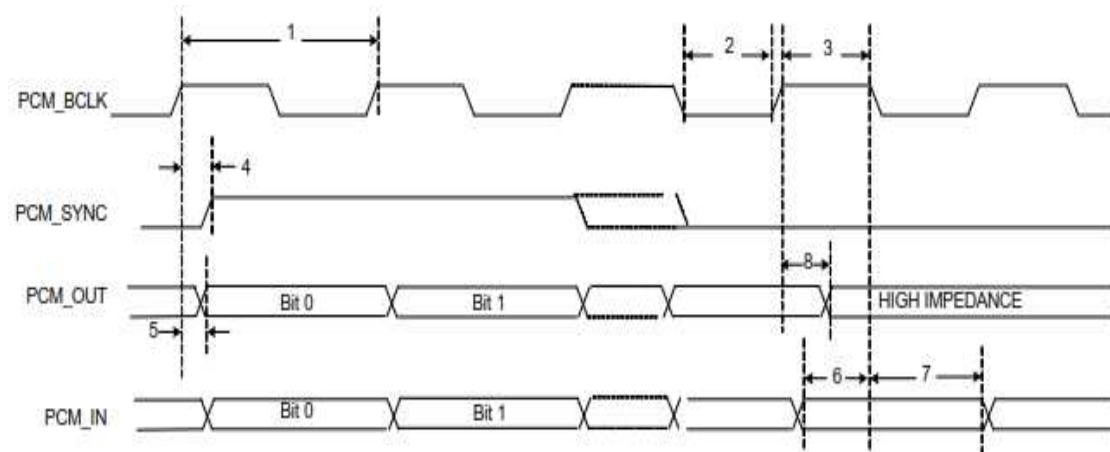

Figure 4: PCM timing diagram (Long-Frame Sync, Master Mode)

Table 13: PCM Interface timing specifications (Long-Frame Sync, Master Mode)

Ref No.	Characteristics	Minimum	Typical	Maximum	Unit
1	PCM bit clock frequency	-	-	12	MHz
2	PCM bit clock LOW	41	-	-	ns
3	PCM bit clock HIGH	41	-	-	ns
4	PCM_SYNC delay	0	-	25	ns
5	PCM_OUT delay	0	-	25	ns
6	PCM_IN setup	8	-	-	ns
7	PCM_IN hold	8	-	-	ns
8	Delay from rising edge of PCM_BCLK during last bit period to PCM_OUT becoming high impedance	0	-	25	ns

Figure 5 and Table 14 shows PCM Timing Diagram and Specifications for the slave mode of long-frame.

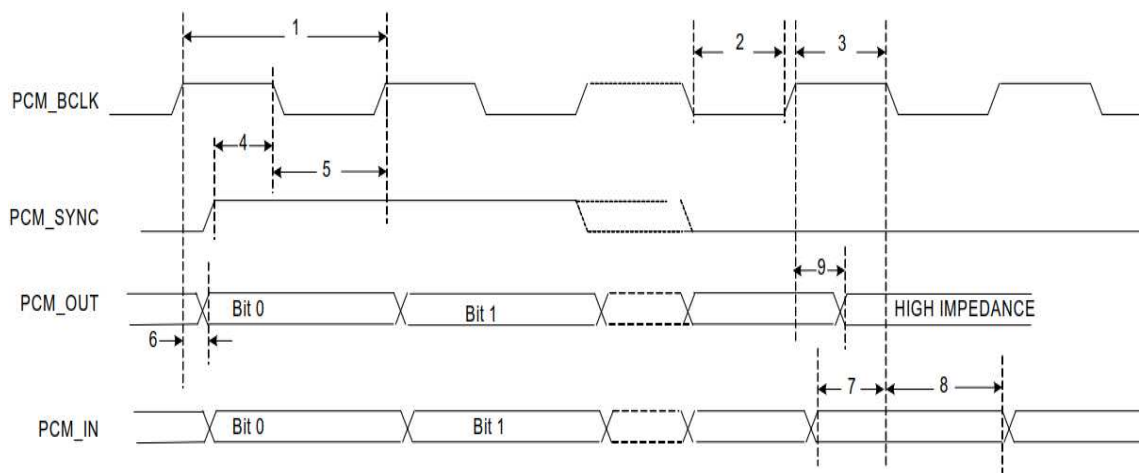

Figure 5: PCM timing diagram (Long-Frame Sync, Slave Mode)

Table 14: PCM Interface timing specifications (Long-Frame Sync, Slave Mode)

Ref No.	Characteristics	Minimum	Typical	Maximum	Unit
1	PCM bit clock frequency	-	-	12	MHz
2	PCM bit clock LOW	41	-	-	ns
3	PCM bit clock HIGH	41	-	-	ns
4	PCM_SYNC setup	8	-	-	ns
5	PCM_SYNC hold	8	-	-	ns
6	PCM_OUT delay	0	-	25	ns
7	PCM_IN setup	8	-	-	ns
8	PCM_IN hold	8	-	-	ns
9	Delay from rising edge of PCM_BCLK during last bit period to PCM_OUT becoming high impedance	0	-	25	ns

8.3.3. Data Formatting

The BT850-Sx may be configured to generate and accept several different data formats. For conventional narrowband speech mode, the BT850-Sx uses 13 of the 16 bits in each PCM frame. The location and order of these 13 bits can be configured to support various data formats on the PCM interface. The remaining three bits are ignored on the input and may be filled with 0s, 1s, a sign bit, or a programmed value on the output. The default format is 13-bit 2's complement data, left justified, and clocked MSB first.

8.3.4. Wideband Speech Support

When the host encodes Wideband Speech (WBS) packets in transparent mode, the encoded packets are transferred over the PCM bus for an eSCO voice connection. In this mode, the PCM bus is typically configured in master mode for a 4-kHz sync rate with 16-bit samples, resulting in a 64 Kbps bit rate. The BT850-Sx also supports slave transparent mode using a proprietary rate-matching scheme. In SBC-code mode, linear 16-bit data at 16 kHz (256 Kbps rate) is transferred over the PCM bus.

8.3.5. Multiplexed Bluetooth Over PCM

Bluetooth supports multiple audio streams within the Bluetooth channel and both 16 kHz and 8 kHz streams can be multiplexed. This mode of operation is only supported when the Bluetooth host is the master. Figure 6 shows the operation of the multiplexed transport with three simultaneous SCO connections. To accommodate additional SCO channels, the transport clock speed is increased. To change between modes of operation, the transport must be halted and restarted in the new configuration.

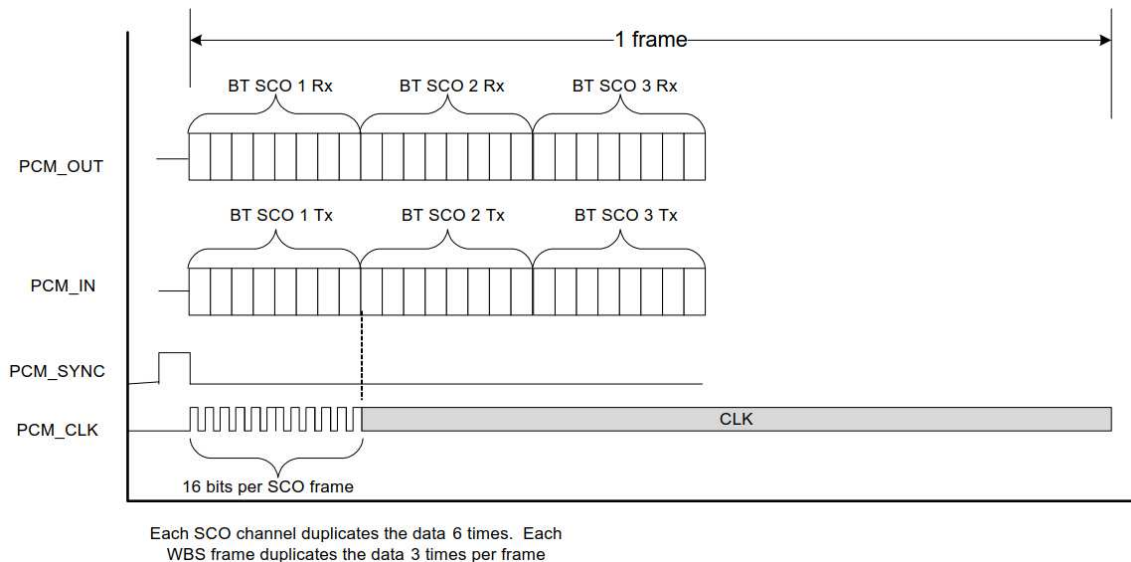

Figure 6: Functional multiples data diagram

8.3.6. Burst PCM Mode

In this mode of operation, the PCM bus runs at a significantly higher rate of operation to allow the host to duty cycle its operation and save current. In this mode of operation, the PCM bus can operate at a rate of up to 24 MHz. This mode of operation is initiated with an HCI command from the host.

Figure 7 and Table 15 shows PCM Burst mode timing diagram and specifications for the receive-only mode of short-frame sync.

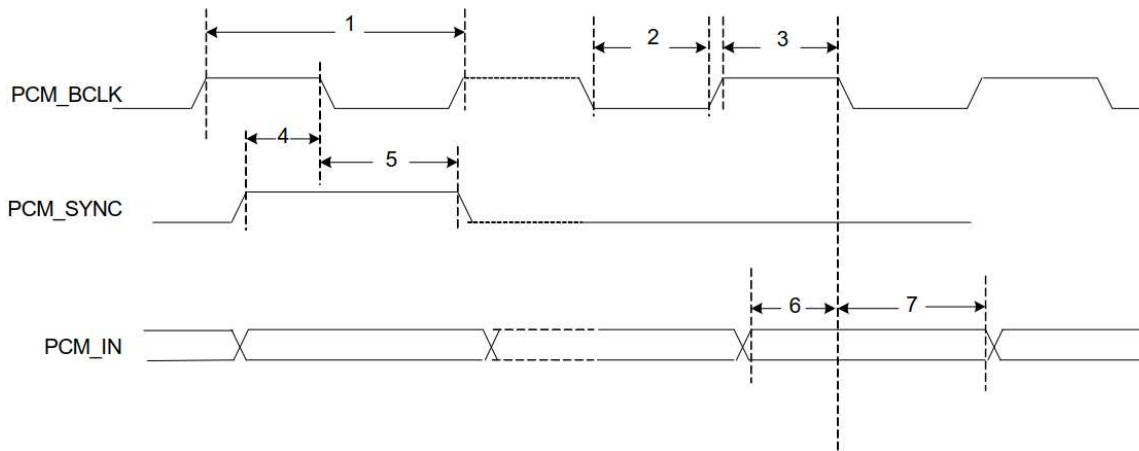

Figure 7: PCM burst mode timing (Receive Only, Short Frame Sync)

Table 15: PCM burst mode specifications (Receive Only, Short-Frame Sync)

Ref No.	Characteristics	Minimum	Typical	Maximum	Unit
1	PCM bit clock frequency	-	-	24	MHz
2	PCM bit clock LOW	20.8	-	-	ns
3	PCM bit clock HIGH	20.8	-	-	ns
4	PCM_SYNC setup	8	-	-	ns
5	PCM_SYNC_hold	8	-	-	ns
6	PCM_IN setup	8	-	-	ns
7	PCM_IN hold	8	-	-	ns

Figure 8 and Table 16 shows PCM Burst mode timing diagram and specifications for the receive-only mode of long-frame sync.

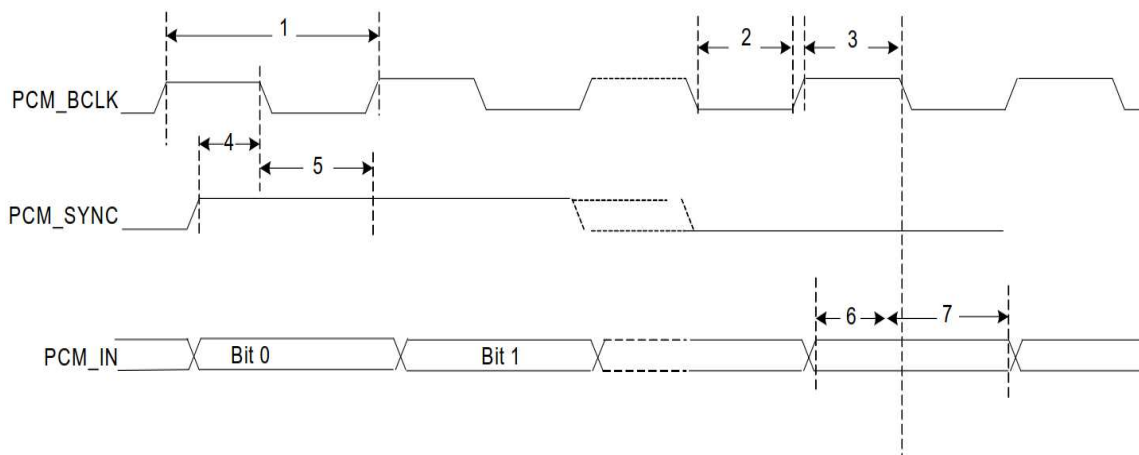

Figure 8: PCM burst mode timing (Receive Only, Long Frame Sync)

Table 16: PCM burst mode specifications (Receive Only, Long-Frame Sync)

Ref No.	Characteristics	Minimum	Typical	Maximum	Unit
1	PCM bit clock frequency	-	-	24	MHz
2	PCM bit clock LOW	20.8	-	-	ns

Ref No.	Characteristics	Minimum	Typical	Maximum	Unit
3	PCM bit clock HIGH	20.8	-	-	ns
4	PCM_SYNC setup	8	-	-	ns
5	PCM_SYNC_hold	8	-	-	ns
6	PCM_IN setup	8	-	-	ns
7	PCM_IN hold	8	-	-	ns

8.4. I²S Interface

The BT850-Sx supports two independent I²S digital audio ports. The I²S interface supports both master and slave modes. The I²S signals are:

- I²S clock: I²S SCK
- I²S Word Select: I²S WS
- I²S Data Out: I²S SDO
- I²S Data In: I²S SDI

I²S SCK and I²S WS become outputs in master mode and inputs in slave mode, while I²S SDO always stays as an output. The channel word length is 16 bits and the data is justified so that the MSB of the left-channel data is aligned with the MSB of the I²S bus, per the I²S specification. The MSB of each data word is transmitted one bit clock cycle after the I²S WS transition, synchronous with the falling edge of bit clock. Left-channel data is transmitted when I²S WS is low, and right-channel data is transmitted when I²S WS is high. Data bits sent by the BT850 are synchronized with the falling edge of I2S_SCK and should be sampled by the receiver on the rising edge of I2S_SSCK.

The clock rate in master mode is either of the following:

$$48 \text{ kHz} \times 32 \text{ bits per frame} = 1.536 \text{ MHz}$$

$$48 \text{ kHz} \times 50 \text{ bits per frame} = 2.400 \text{ MHz}$$

The master clock is generated from the input reference clock using a N/M clock divider.

In the slave mode, any clock rate is supported to a maximum of 3.072 MHz.

8.4.1. I²S Timing

Timing values specified in Table 17 are relative to high and low threshold levels.

Table 17: Timing for I2S transmitters and receivers

	Transmitter				Receiver				Notes
	Lower Limit		Upper Limit		Lower Limit		Upper Limit		
	Min	Max	Min	Max	Min	Max	Min	Max	
Clock Period T	T _{tr}	-	-	-	T _r	-	-	-	
Master Mode: Clock generated by transmitter or receiver									
HIGH t _{HC}	0.35T _{tr}	-	-	-	0.35T _{tr}	-	-	-	
LOW t _{LC}	0.35T _{tr}	-	-	-	0.35T _{tr}	-	-	-	
Master Mode: Clock generated by transmitter or receiver									
HIGH t _{HC}	-	0.35T _{tr}	-	-	-	0.35T _{tr}	-	-	
LOW t _{LC}	-	0.35T _{tr}	-	-	-	0.35T _{tr}	-	-	

	Transmitter				Receiver				Notes
Rise time t_{RC}	-	-	$0.15T_{tr}$	-	-	-	-	-	
Transmitter									
Delay t_{dtr}	-	-	-	$0.8T$	-	-	-	-	
Hold time t_{htr}	0	-	-	-	-	-	-	-	
Receiver									
Setup time t_{sr}	-	-	-	-	-	$0.2T_r$	-	-	
Hold time t_{hr}	-	-	-	-	-	0	-	-	

The time periods specified in Figure 9 and Figure 10 are defined by the transmitter speed. The receiver specifications must match transmitter performance.

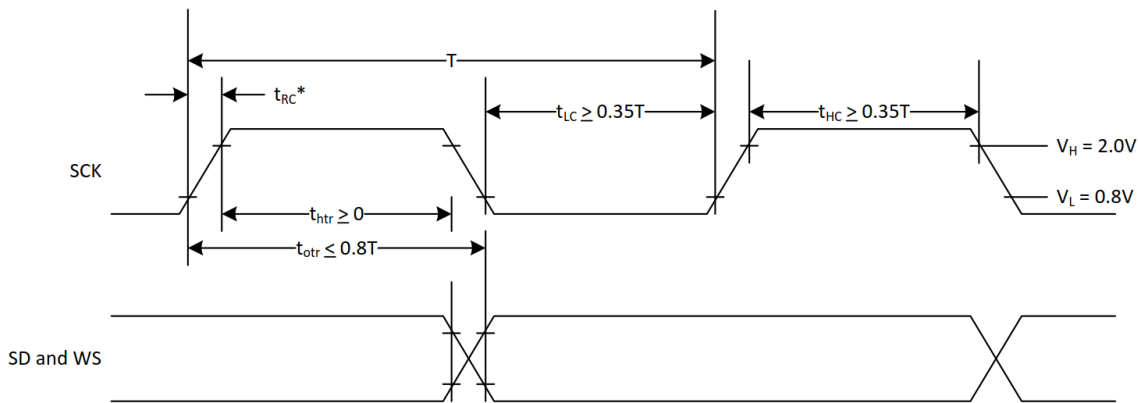

T = Clock period
 T_{tr} = Minimum allowed clock period for transmitter
 $T = T_{tr}$
 * t_{RC} is only relevant for transmitters in slave mode.

Figure 9: I2S transmitter timing

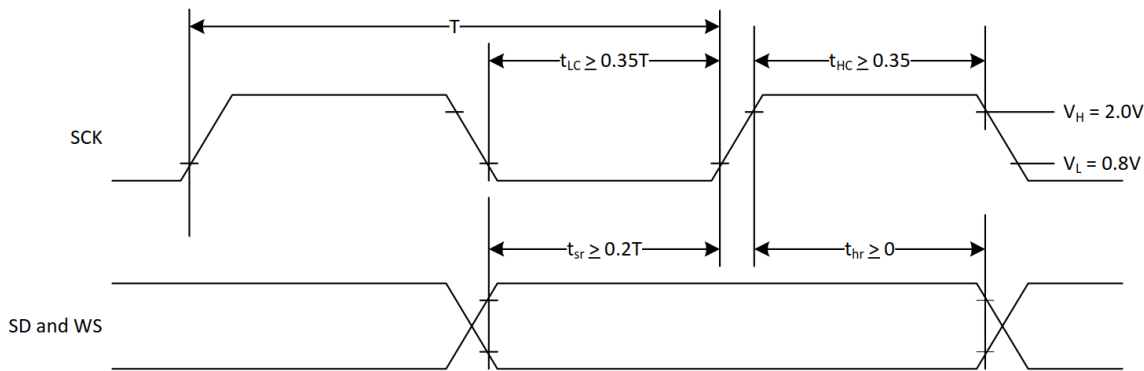

T = Clock period
 T_r = Minimum allowed clock period for transmitter
 $T > T_r$

Figure 10: I2S receiver timing

9 ANTENNA PERFORMANCE

Table 18, Figure 11: Antenna return loss, Figure 12, and Figure 12 shows the antenna gain and performance.

Table 18: Antenna gain

Unit in dBi @ 2440 MHz	XY-plane		XZ-plane		YZ-plane		Efficiency
	Peak	Avg.	Peak	Avg.	Peak	Avg.	
AT3216-B2R7HAA	0.1	-4.1	1.8	-3.3	-0.2	-6.8	41%

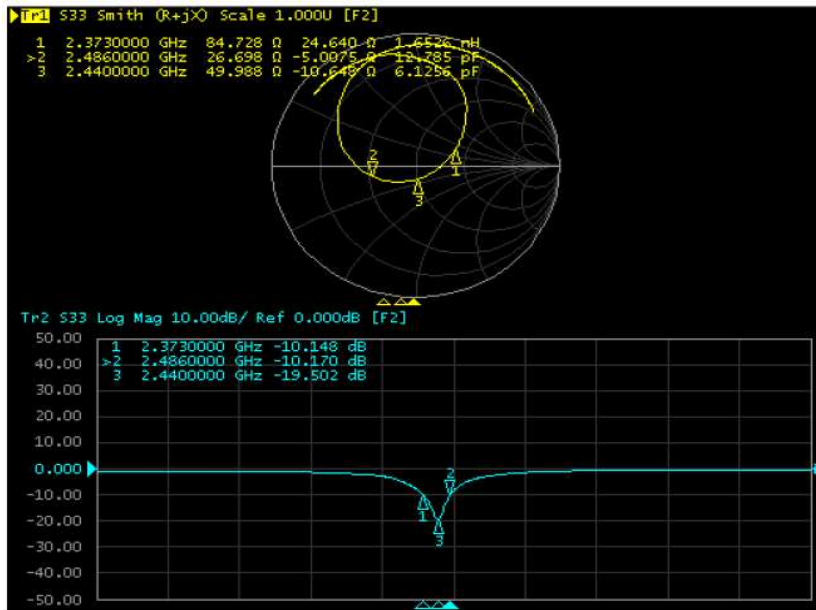

Figure 11: Antenna return loss

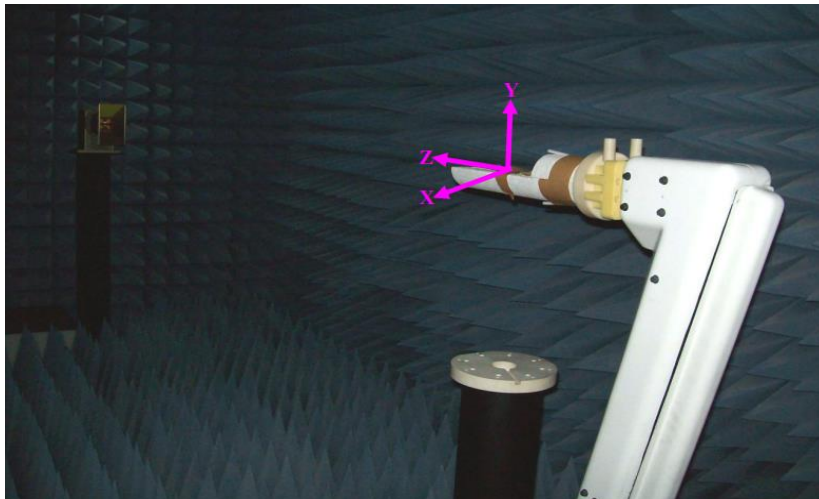
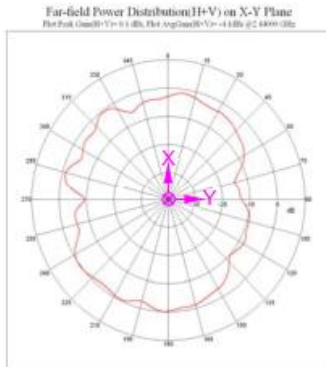

Figure 11: Measurement XYZ polarization

Table 19: Plane definitions

XY - Plane	Theta = 90°
XZ – Plane	Phi = 0°
YZ - Plane	Phi = 90°

◆XY-plane



Unit : dBi

	Peak gain	Avg. gain
XY-plane	0.1	-4.1

◆XZ-plane

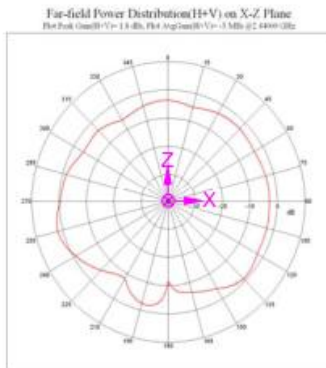

	Peak gain	Avg. gain
XZ-plane	1.8	-3.3

◆YZ-plane

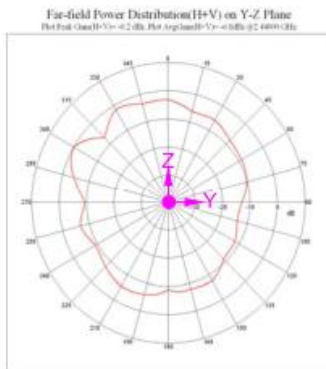

	Peak gain	Avg. gain
YZ-plane	-0.2	-6.8

Figure 12: Antenna patterns

10 MECHANICAL DIMENSIONS AND LAND PATTERN

10.1. BT850-Sx Mechanical Drawing

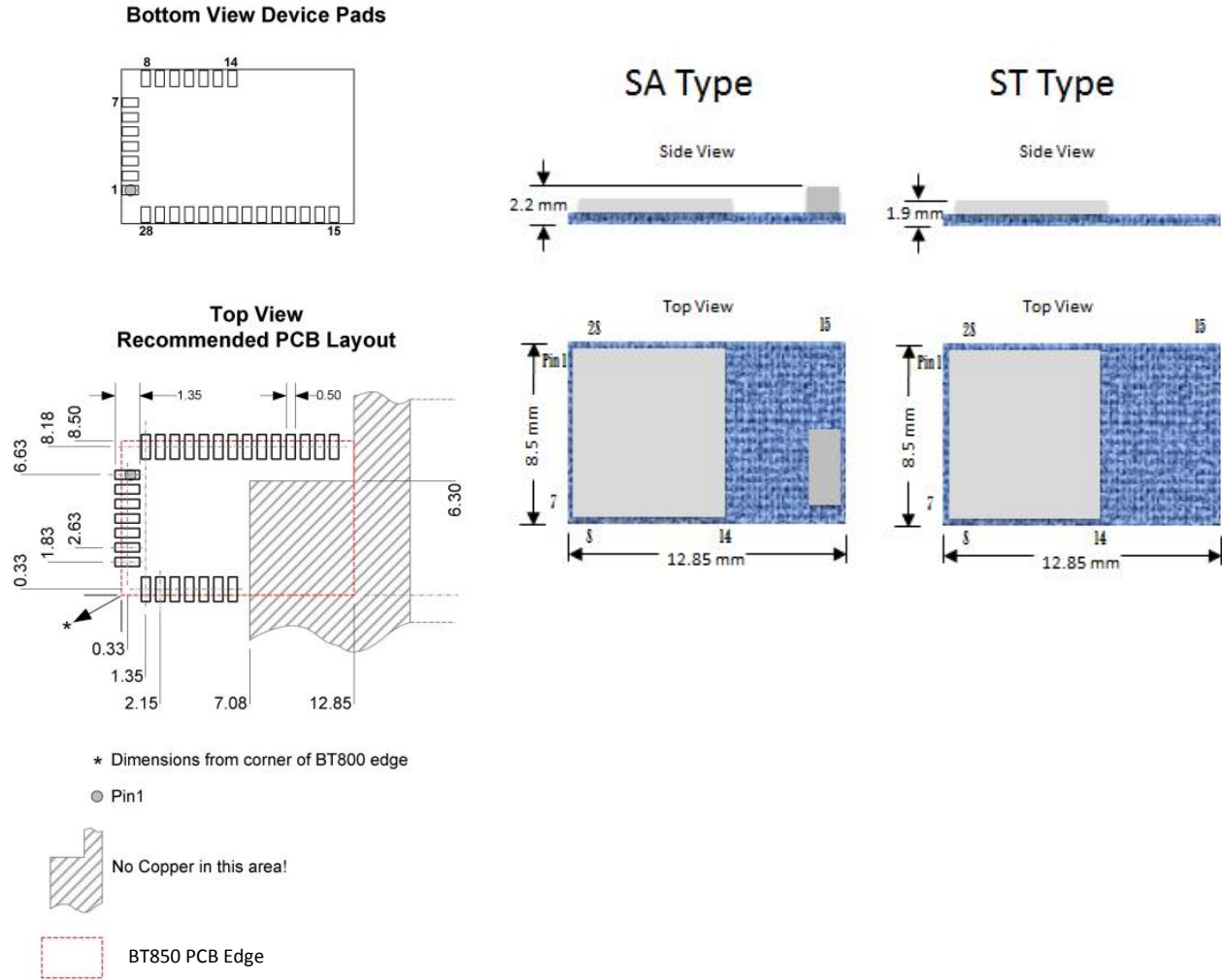

Note: Dimensions are in millimetres
 Tolerances: .xx ±0.03 mm
 .x ±1.3 mm

11 IMPLEMENTATION NOTE

11.1. PCB Layout on Host PCB

Checklist (for PCB):

- **MUST** locate the BT850 module close to the edge of PCB.
- Use solid GND plane on inner layer (for best EMC and RF performance).
- Place GND vias close to module GND pads as possible
- Route traces to avoid noise being picked up on VCC supply.
- Antenna Keep-out area:
 - Ensure there is no copper in the antenna keep-out area on any layers of the host PCB.
 - Keep all mounting hardware and metal clear of the area to allow proper antenna radiation.
 - For best antenna performance, place the BT850 module on the edge of the host PCB, preferably in the corner with the antenna facing the corner.
 - A different host PCB thickness dielectric will have small effect on antenna.

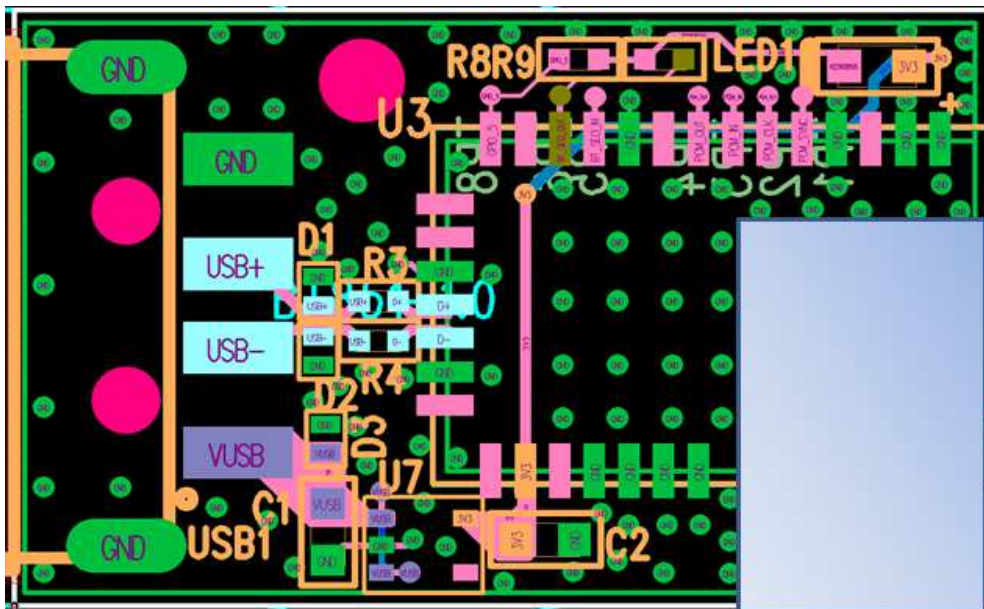

Figure 13: Recommend antenna keep-out area (in blue) used on the BT850

11.1.1. Antenna Keep-out and Proximity to Metal or Plastic

Checklist (for metal/plastic enclosure):

- Minimum safe distance for metals without seriously compromising the antenna (tuning) is 40 mm top/bottom and 30 mm left or right.
- Metal close to the BT850-SA chip monopole antenna (bottom, top, left, right, any direction) will have degradation on the antenna performance. The amount of degradation is entirely system-dependent which means some testing by customers is required (in their host application).
- Any metal closer than 20 mm starts to significantly degrade performance (S11, gain, radiation efficiency).
- It is best that the customer tests the range with mock-up (or actual prototype) of the product to assess effects of enclosure height (and material, whether metal or plastic).

11.1.2. USB Dongle Design Example Using BT850-SA

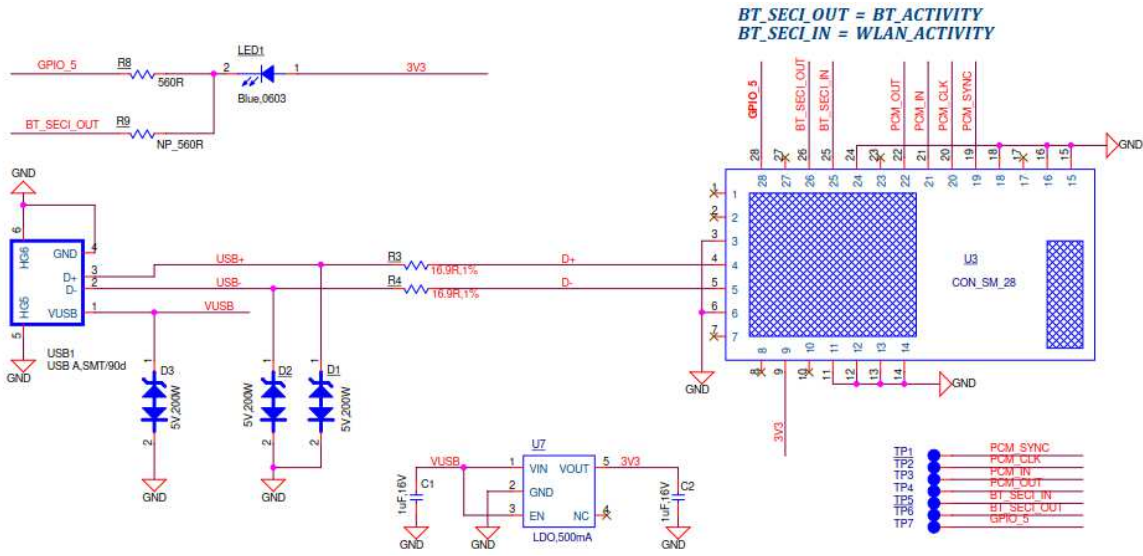

Figure 14: USB dongle design schematic

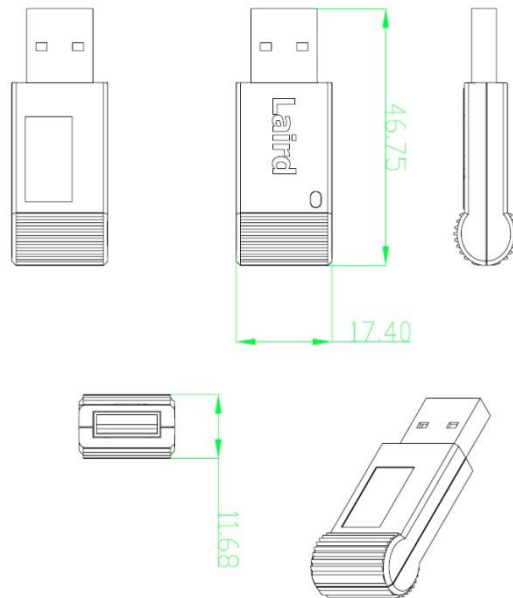

Figure 15: BT851 USB dongle, containing embedded BT850-SA

12 APPLICATION NOTE FOR SURFACE MOUNT MODULES

12.1. Introduction

Laird surface mount modules are designed to conform to all major manufacturing guidelines. This application note is intended to provide additional guidance beyond the information that is presented in the user manual. This application note is considered a living document and is updated as new information is presented.

The modules are designed to meet the needs of a number of commercial and industrial applications. They are easy to manufacture and they conform to current automated manufacturing processes.

12.2. Shipping

12.2.1. Tape and Reel Package Information

Note: Ordering information for Tape and Reel packaging is an addition of T/R to the end of the full module part number. For example, BT850-Sx becomes BT850-Sx-T/R.

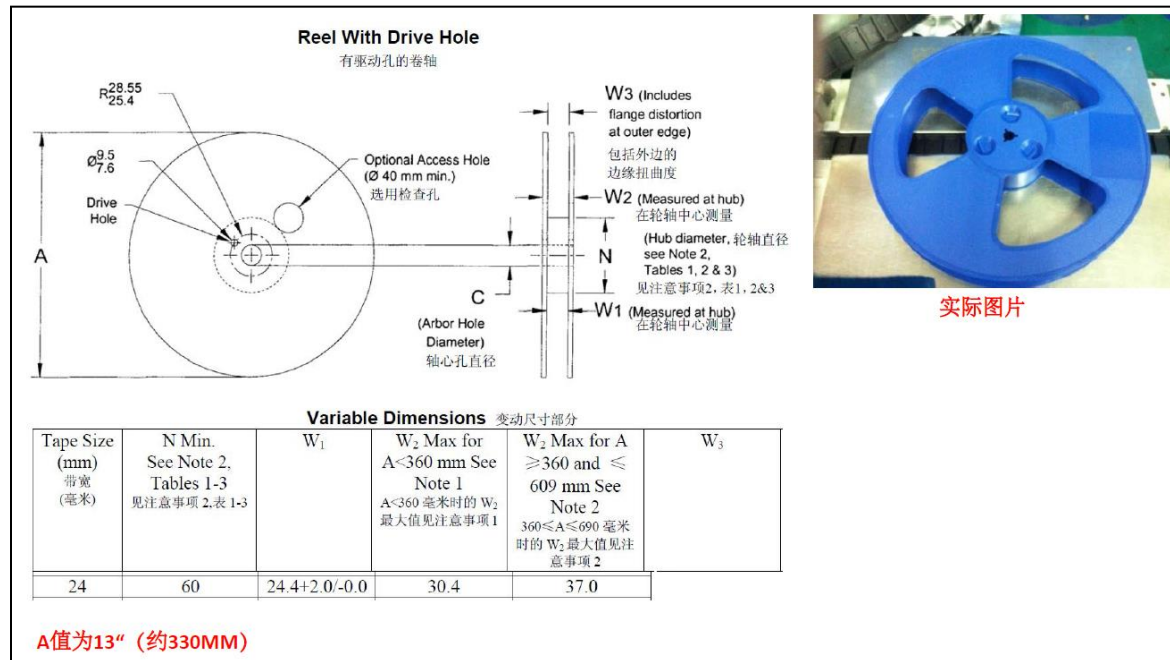

Figure 16: Reel specifications

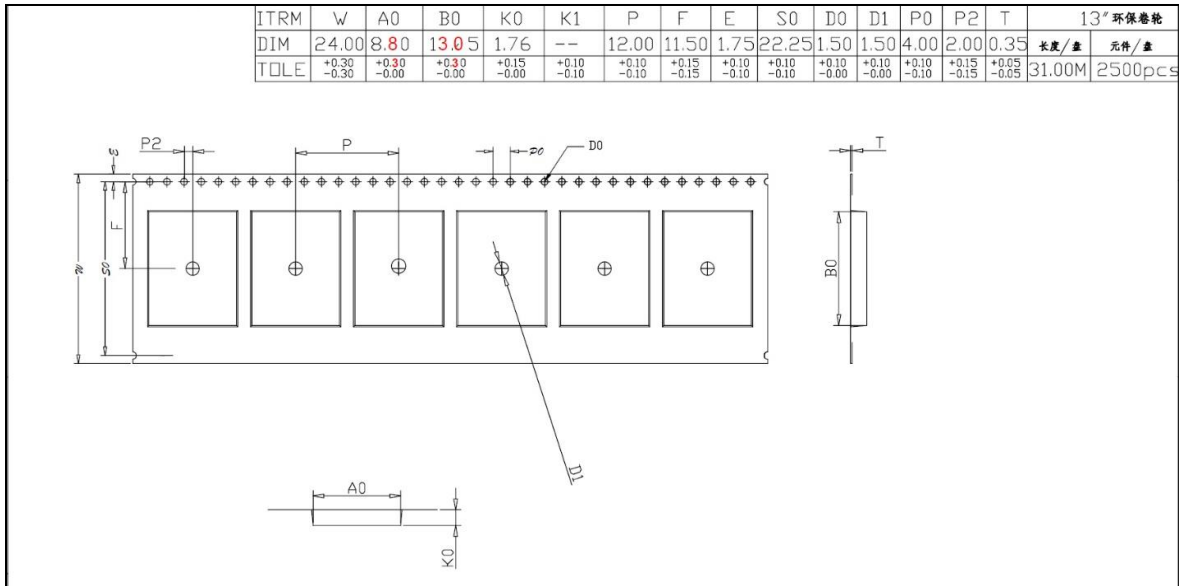

Figure 17: Tape specifications

There are 2500 BT850-Sx modules taped in a reel (and packaged in a pizza box) and five boxes per carton (12,500 modules per carton). Reel, boxes, and carton are labeled with the appropriate labels. See [Figure 18](#).

12.2.2. Packaging Process

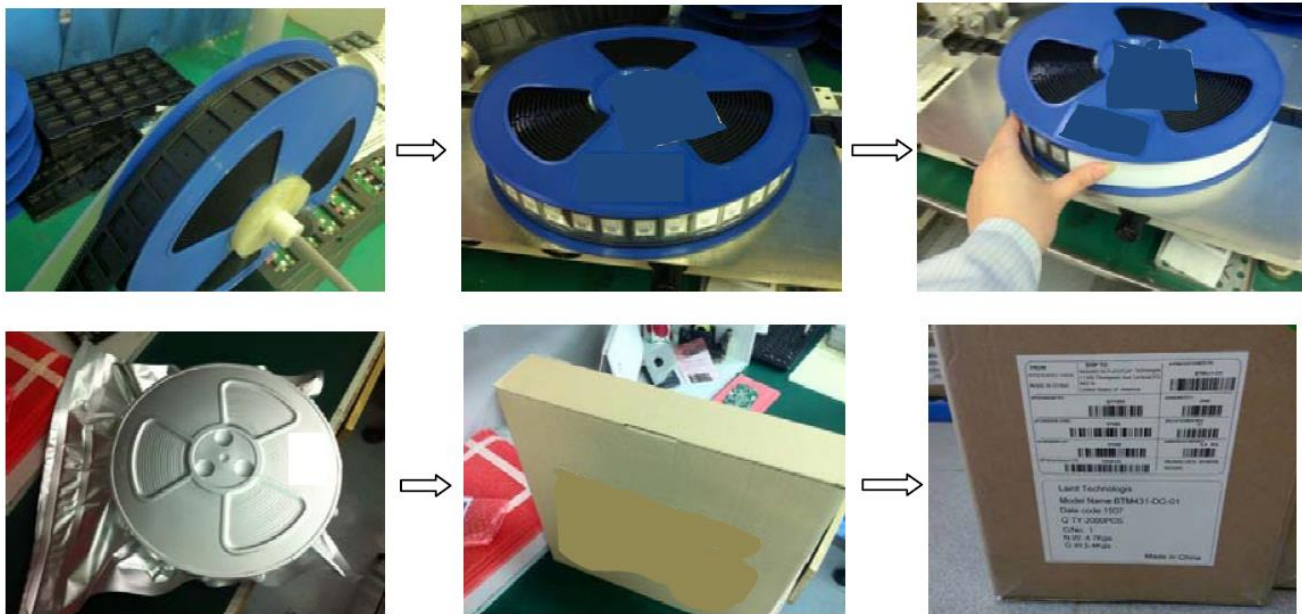

Figure 18: Packaging process

12.3. Reflow Parameters

Laird surface mount modules are designed to be easily manufactured, including reflow soldering to a PCB. Ultimately it is the responsibility of the customer to choose the appropriate solder paste and to ensure oven temperatures during reflow meet the requirements of the solder paste. Laird’s surface mount modules conform to J-STD-020D1 standards for reflow temperatures.

Important: During reflow, modules should not be above 260° and not for more than 30 seconds. In addition, strongly recommend doesn’t let the module to go through the reflow over 1 time. Otherwise, it will to impact the soldering of module own.

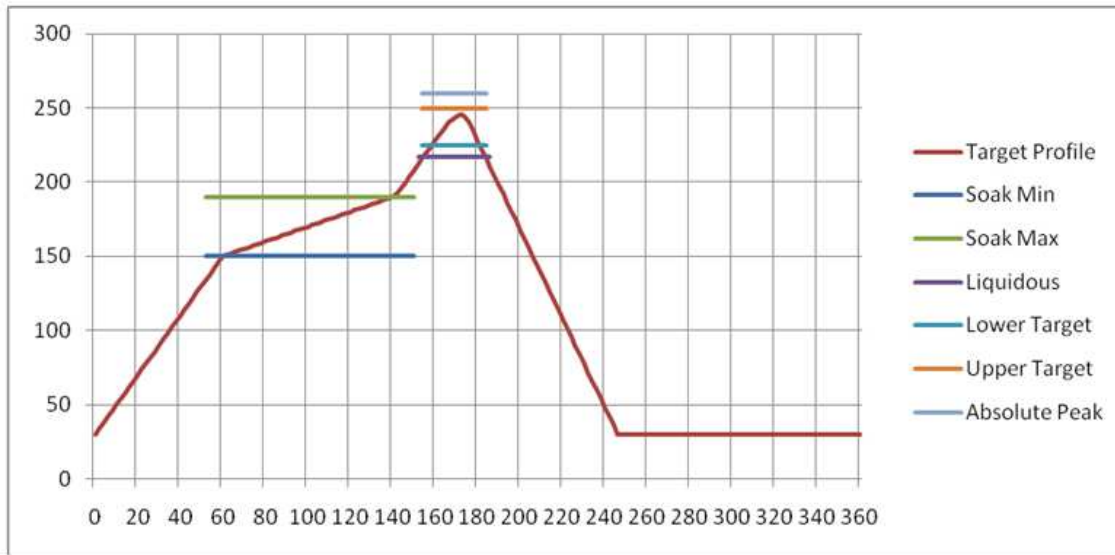

Figure 19: Recommended reflow temperature

Temperatures should not exceed the minimums or maximums presented in Table 20.

Table 20: Recommended maximum and minimum temperatures

Specification	Value	Unit
Temperature Inc./Dec. Rate (max)	1~3	°C / Sec
Temperature Decrease rate (goal)	2-4	°C / Sec
Soak Temp Increase rate (goal)	.5 - 1	°C / Sec
Flux Soak Period (Min)	70	Sec
Flux Soak Period (Max)	120	Sec
Flux Soak Temp (Min)	150	°C
Flux Soak Temp (max)	190	°C
Time Above Liquidous (max)	70	Sec
Time Above Liquidous (min)	50	Sec
Time in Target Reflow Range (goal)	30	Sec
Time at Absolute Peak (max)	5	Sec
Liquidous Temperature (SAC305)	218	°C
Lower Target Reflow Temperature	240	°C