



Chipsmall Limited consists of a professional team with an average of over 10 year of expertise in the distribution of electronic components. Based in Hongkong, we have already established firm and mutual-benefit business relationships with customers from,Europe,America and south Asia,supplying obsolete and hard-to-find components to meet their specific needs.

With the principle of “Quality Parts,Customers Priority,Honest Operation,and Considerate Service”,our business mainly focus on the distribution of electronic components. Line cards we deal with include Microchip,ALPS,ROHM,Xilinx,Pulse,ON,Everlight and Freescale. Main products comprise IC,Modules,Potentiometer,IC Socket,Relay,Connector.Our parts cover such applications as commercial,industrial, and automotives areas.

We are looking forward to setting up business relationship with you and hope to provide you with the best service and solution. Let us make a better world for our industry!



Contact us

Tel: +86-755-8981 8866 Fax: +86-755-8427 6832

Email & Skype: info@chipsmall.com Web: www.chipsmall.com

Address: A1208, Overseas Decoration Building, #122 Zhenhua RD., Futian, Shenzhen, China



HITFET - BTS3205G

Smart Low-Side Power Switch

Automotive Power



Never stop thinking

1	Overview	3
2	Block Diagram	5
2.1	Terms	5
3	Pin Configuration	6
3.1	Pin Assignment BTS3205G	6
3.2	Pin Definitions and Functions	6
4	General Product Characteristics	7
4.1	Absolute Maximum Ratings	7
4.2	Thermal Resistance	8
4.2.1	Transient Thermal Impedance	8
5	Block Description and Characteristics	10
5.1	Input and Power Stage	10
5.1.1	Input Circuit	10
5.1.2	Failure Feedback	11
5.1.3	Output On-State Resistance	11
5.1.4	Power Dissipation	12
5.1.5	Output Timing	12
5.1.6	Characteristics	13
6	Protection Functions	15
6.1	Thermal Protection	15
6.2	Overvoltage Protection	15
6.3	Short Circuit Protection	17
6.4	Characteristics	18
7	Package Outlines BTS3205G	19
8	Revision History	20



1 Overview

Features

- Low input current
- Short circuit and Overload protection
- Current limitation
- Input protection (ESD)
- Thermal protection with auto restart
- Compatible to standard Power MOSFET
- Analog driving possible
- Green Product (RoHS compliant)
- AEC Qualified

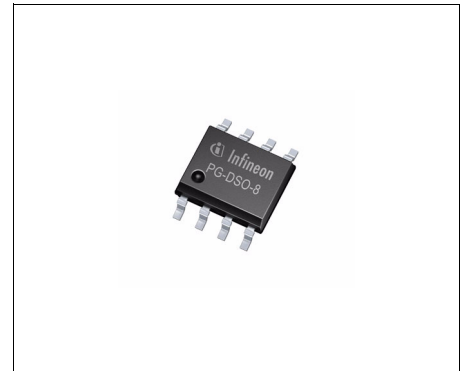

PG-DSO-8-24

Description

The BTS3205G is a one channel low-side power switch in PG-DSO-8-24 package providing embedded protective functions. The device is monolithic integrated and consist of an N-channel power MOSFET transistor and additional protection circuitry.

Table 1 Product Summary

Drain Voltage	V_D	42 V ¹⁾
Input Voltage	$V_{IN(max)}$	10 V
Typical On-State Resistance at $T_j = 25^\circ\text{C}$ and $V_{in} = 10\text{V}$	$R_{DS(ON,amb typ)}$	0.7 Ω
Maximum On-State Resistance at $T_j = 150^\circ\text{C}$ and $V_{in} = 10\text{V}$	$R_{DS(ON,hot max)}$	1.9 Ω
Nominal Load Current	$I_{Dnom(min)}$	350 mA
Drain Current	I_D	600 mA ²⁾
Single Clamping Energy	E_{AS}	65 mJ

1) Active clamped

2) Internally limited

Type	Package	Marking
BTS3205G	PG-DSO-8-24	BTS3205G

Protective Functions

- Electrostatic discharge protection (ESD)
- Active clamp over voltage protection
- Thermal shutdown with auto restart
- Short circuit protection

Fault Information

- Thermal shutdown
- Short to Battery and overload

Applications

- Designed for driving Relays in Automotive Applications
- All types of resistive, inductive and capacitive loads
- Suitable for loads with peak currents
- Replaces discrete circuits

Detailed Description

The device is able to switch all kind of resistive, inductive and capacitive loads, limited by E_{AS} and maximum current capabilities.

The BTS3205G offers ESD protection of the IN Pin in relation to the Source Pin.

The overtemperature protection prevents the device from overheating due to overload and/or bad cooling conditions. The temperature information is given by a temperature sensor in the power MOSFET. During thermal shutdown the device tries to sink an increased input current to feedback the fault condition.

The BTS3205G has a thermal-auto-restart function, the device will turn on again after the measured temperature has dropped down for the thermal hysteresis.

The over voltage protection is active during load-dump or inductive turn off conditions. The power MOSFET is limiting the Drain - Source voltage to the defined clamping voltage. This function is available regardless of the input pin state.

2 Block Diagram

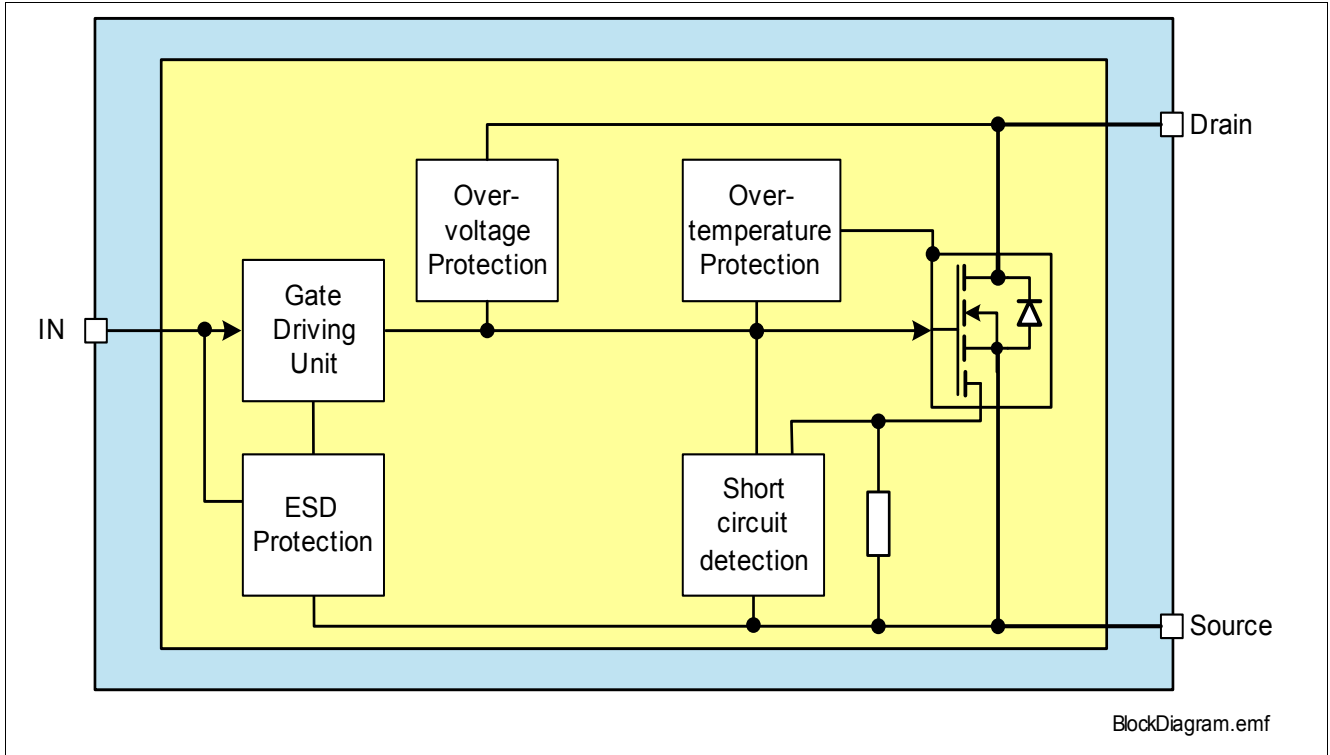

Figure 1 Block Diagram

2.1 Terms

Figure 2 shows all external terms used in this data sheet.

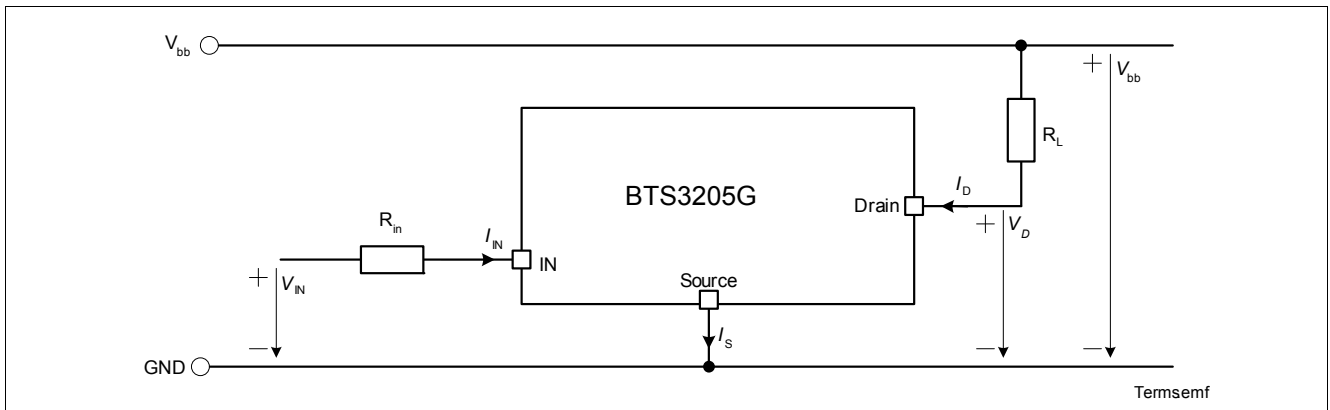

Figure 2 Terms

3 Pin Configuration

3.1 Pin Assignment BTS3205G

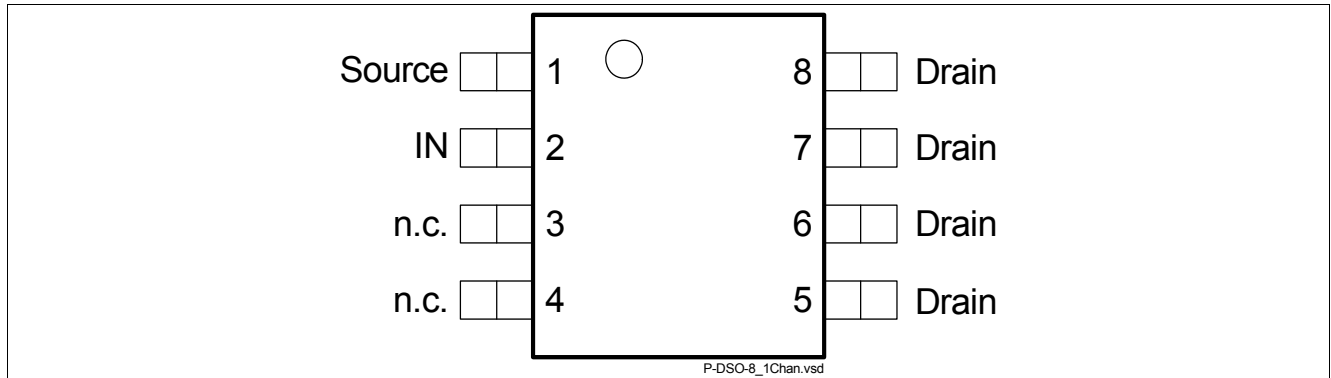

Figure 3 Pin Configuration PG-DSO-8-24

3.2 Pin Definitions and Functions

Pin	Symbol	Function
1	Source	Ground connection
2	IN	Input / Fault feedback
3, 4	nc	not connected
5, 6, 7, 8	Drain	Load connection

4 General Product Characteristics

4.1 Absolute Maximum Ratings

Absolute Maximum Ratings ¹⁾

$T_j = -40 \text{ °C}$ to $+150 \text{ °C}$; all voltages with respect to ground, positive current flowing into pin
(unless otherwise specified)

Pos.	Parameter	Symbol	Limit Values		Unit	Test Conditions
			Min.	Max.		
Voltages						
4.1.1	Drain voltage	V_D	–	42	V	²⁾ $V_{IN} = 0 \text{ V}$, $I_D = 10 \text{ mA}$
4.1.2	Input Voltage	V_{IN}	-0.2	10	V	–
4.1.3	Input Current	I_{IN}	self limited		mA	$-0.2 \text{ V} < V_{IN} < 10 \text{ V}$
4.1.4			-2	2	mA	$V_{IN} < -0.2 \text{ V}$ or $V_{IN} > 10 \text{ V}$
4.1.5	Drain Current	I_D	–	600	mA	³⁾ $T_j = 25 \text{ °C}$
Energies						
4.1.6	Unclamped single pulse inductive energy single pulse	E_{AS}	0	65	mJ	$I_D = 350 \text{ mA}$; $V_{bb} = 28 \text{ V}$; $T_{J(\text{start})} = 85 \text{ °C}$
4.1.7	Unclamped single pulse inductive energy single pulse		–	30	mJ	$I_D = 250 \text{ mA}$; $V_{bb} = 28 \text{ V}$; $T_{J(\text{start})} = 150 \text{ °C}$
4.1.8	Unclamped repetitive pulse inductive energy 1×10^4 cycles	E_{AR}	0	18	mJ	$I_D = 200 \text{ mA}$; $V_{bb} = 13.5 \text{ V}$; $T_{J(\text{start})} = 105 \text{ °C}$
4.1.9	Unclamped repetitive pulse inductive energy 1×10^6 cycles		–	13	mJ	$I_D = 170 \text{ mA}$; $V_{bb} = 13.5 \text{ V}$; $T_{J(\text{start})} = 105 \text{ °C}$
4.1.10	Total Power Dissipation	P_{tot}	–	0.78	W	⁴⁾ $T_a = 85 \text{ °C}$
Temperatures						
4.1.11	Operating temperature	T_j	-40	+150	°C	–
4.1.12	Storage temperature	T_{stg}	-55	+150	°C	–
ESD Susceptibility						
4.1.13	Electrostatic discharge voltage ⁵⁾	V_{ESD}	-2	2	kV	IN Pin $R = 1.5 \text{ k}$; $C = 100 \text{ pF}$; $T_j = 25 \text{ °C}$

1) Not subject to production test, specified by design.

2) Active clamped.

3) Internally limited.

4) Device mounted on PCB according EIA/JEDEC standard JESD51-7 (4-layer FR4, 76.2 mm × 114.3 mm with buried planes). PCB is mounted vertical without blown air.

5) ESD susceptibility HBM according to EIA/JESD 22-A 114B, section 4.

4.2 Thermal Resistance

Pos.	Parameter	Symbol	Limit Values			Unit	Conditions
			Min.	Typ.	Max.		
4.2.1	Junction to Soldering Point	R_{thJC}	–	–	44	K/W	1) 2)
4.2.2	Junction to Ambient	R_{thJA}	–	90	–	K/W	1) 2)

1) Not subject to production test, specified by design.

2) Device mounted on PCB according EIA/JEDEC standard JESD51-7 (4-layer FR4, 76.2 mm × 114.3 mm with buried planes). PCB is mounted vertical without blown air with 0.78W power dissipation generated on the DMOS.

Note: Stresses above the ones listed here may cause permanent damage to the device. Exposure to absolute maximum rating conditions for extended periods may affect device reliability.

Note: Integrated protection functions are designed to prevent IC destruction under fault conditions described in the data sheet. Fault conditions are considered as “outside” normal operating range. Protection functions are not designed for continuous repetitive operation.

4.2.1 Transient Thermal Impedance

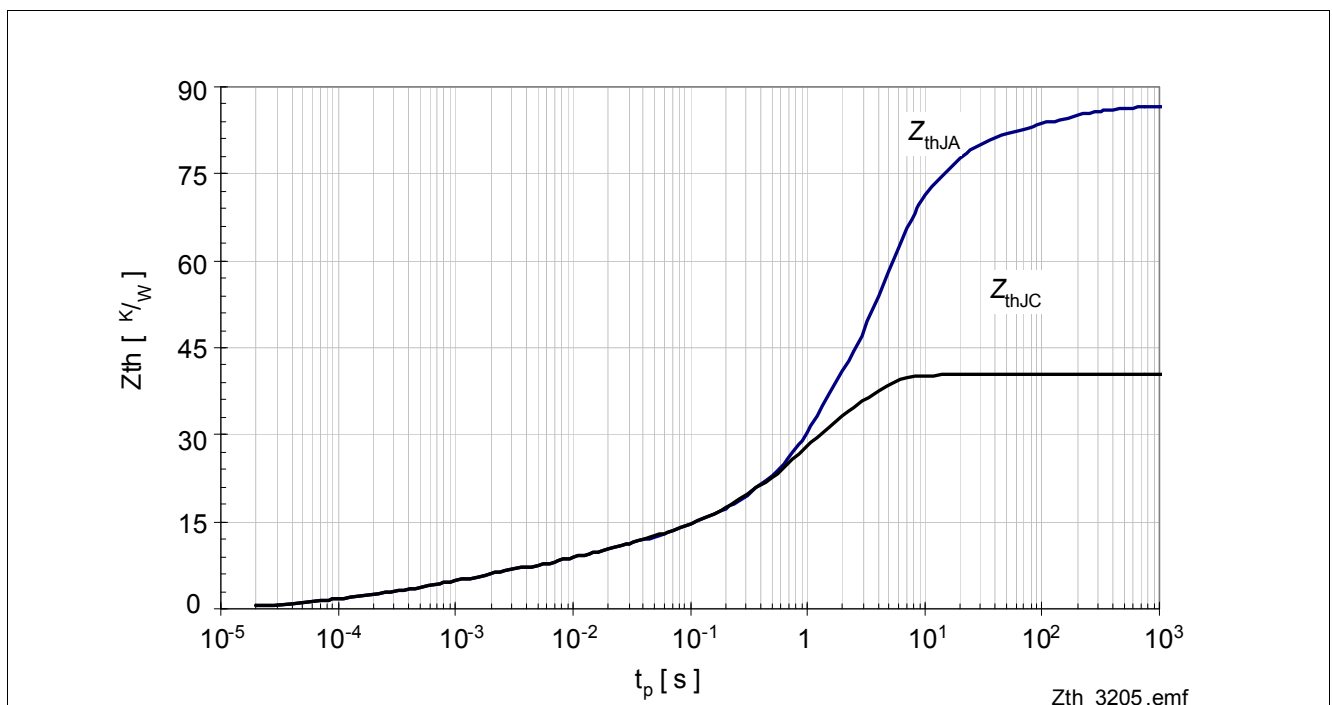

Figure 4 Typical Transient Thermal Impedance single pulse, Z_{thJA} and Z_{thJC}

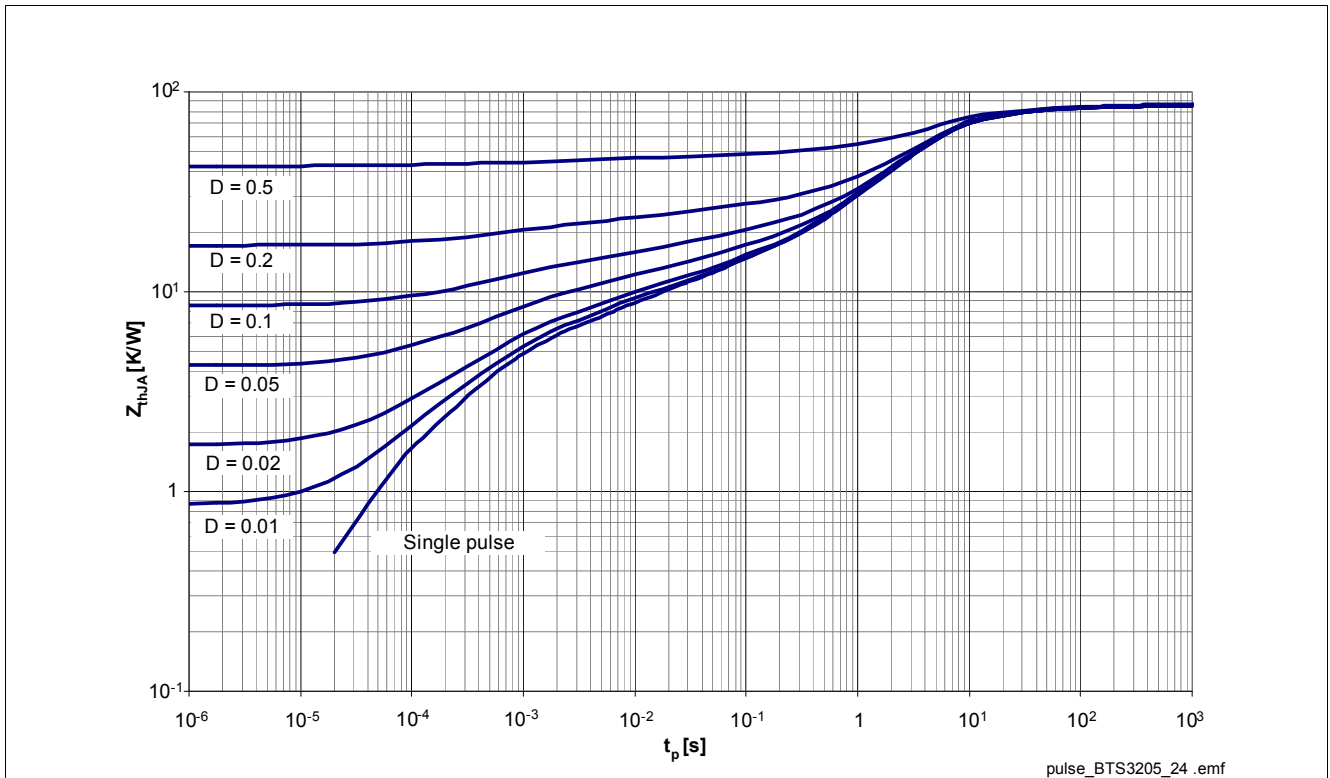

Figure 5 Typical Transient Thermal Impedance Z_{thJA} with different Duty cycles

$$Z_{thJA} = f(t_p), D = t_p/T, T_a = 25\text{ °C}$$

Device mounted on PCB according EIA/JEDEC standard JESD51-7 (4-layer FR4, 76.2 mm × 114.3 mm with buried planes). PCB is mounted vertical without blown air with 0.78W power dissipation generated for single pulse on the DMOS

5 Block Description and Characteristics

5.1 Input and Power Stage

5.1.1 Input Circuit

Figure 6 shows the input circuit of the BTS3205G. The zener Diode protects the input circuit against ESD pulses. The internal circuitry is supplied by the input PIN. During normal operation the Input is connected to the Gate of the power MOSFET. During fault condition the device tries to sink the current I_{INlim} in order to give the fault information back to the driving circuit.

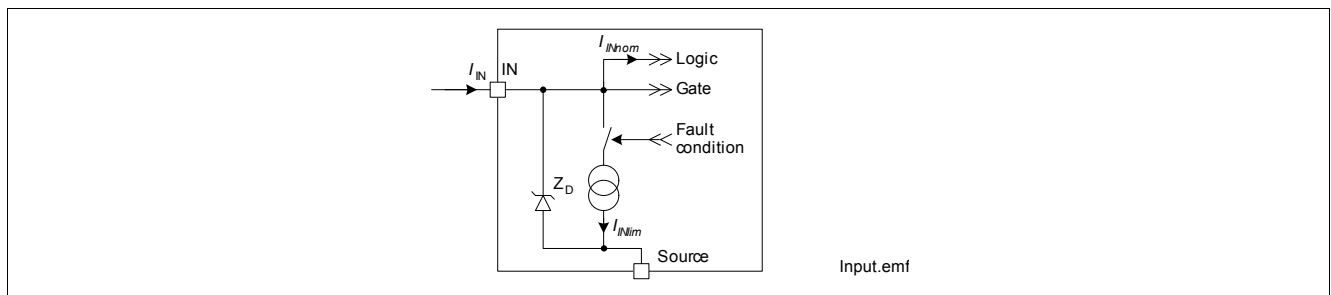

Figure 6 Input Circuit

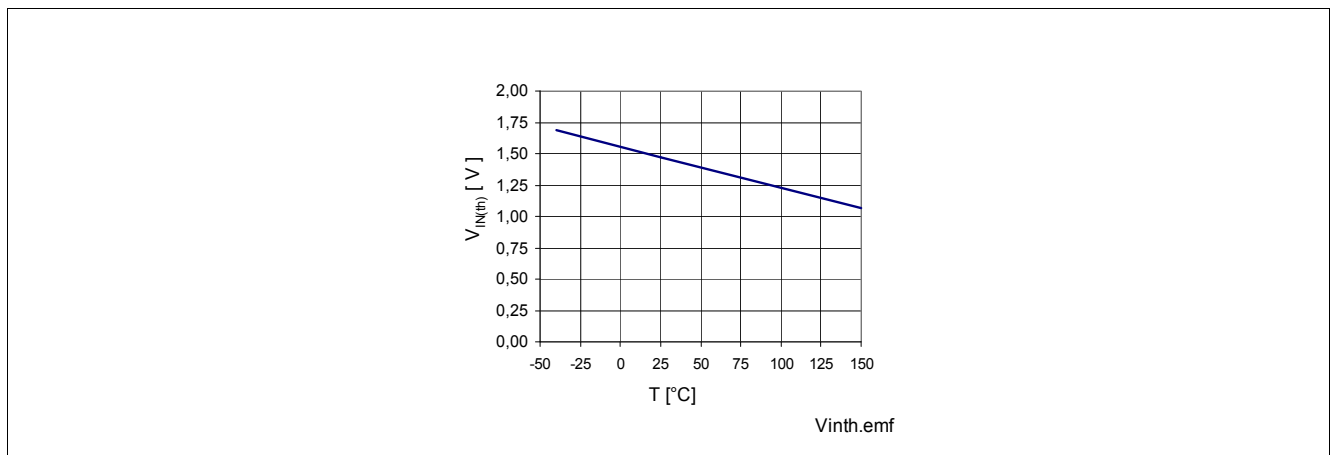

Figure 7 Typical Input Threshold Voltage $V_{in th} = f(T_J)$; $I_D = 50 \mu A$, $V_D = V_{IN}$

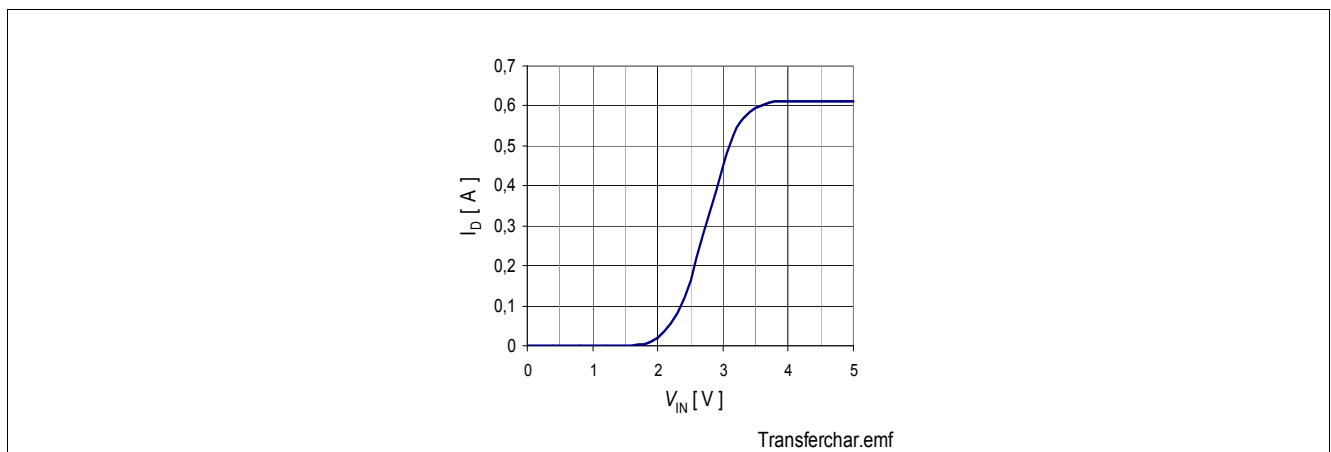

Figure 8 Typical Transfer Characteristic $I_D = f(V_{IN})$; $V_D = 12 V$, $T_{Jstart} = 25 \text{ }^\circ\text{C}$

5.1.2 Failure Feedback

During failure condition the BTS3205G tries to sink a increased input current I_{Nlim} .

5.1.3 Output On-State Resistance

The on-state resistance depends on the junction temperature T_J . **Figure 9** shows this dependency for the typical on-state resistance $R_{DS(on)}$.

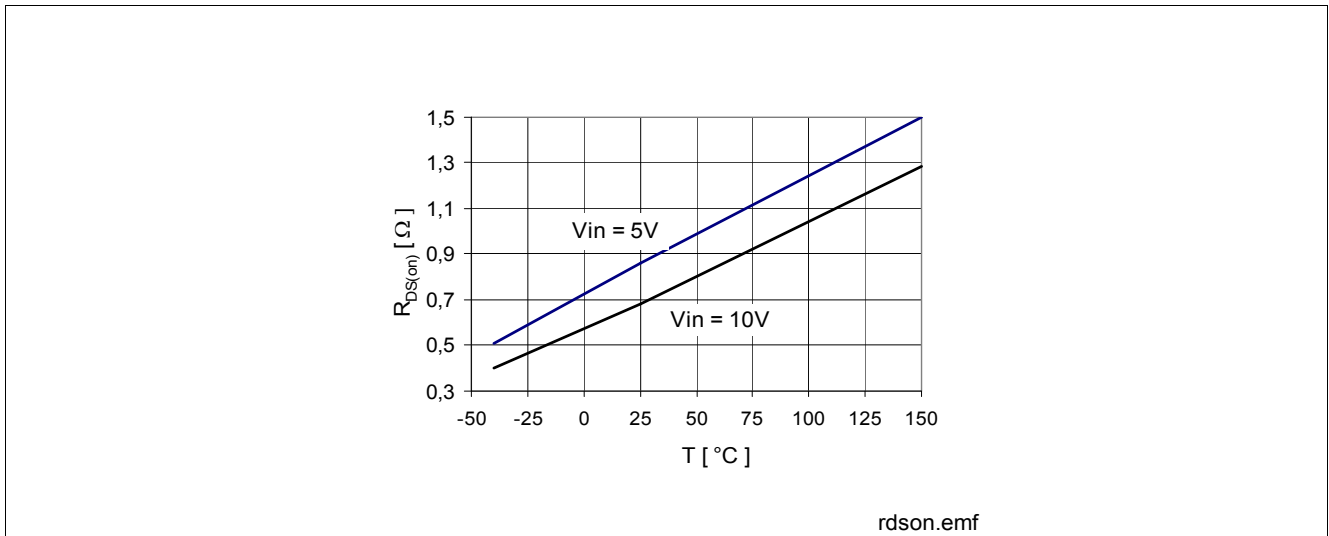

Figure 9 Typical On-State Resistance, $R_{DS(on)} = f(T_J)$

5.1.4 Power Dissipation

The maximum allowed power dissipation in [Figure 10](#) is calculated by R_{thJC} and R_{thJA} .

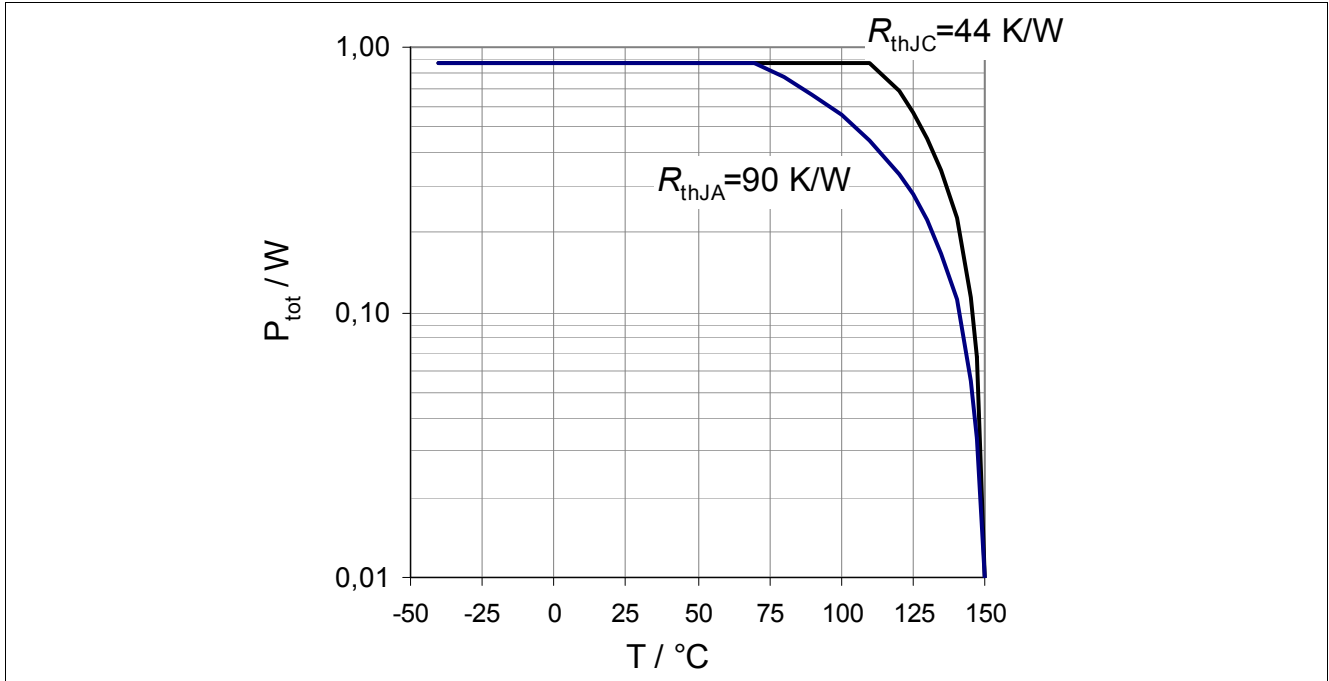

Figure 10 Maximal Allowable Power Dissipation

5.1.5 Output Timing

A voltage signal at the input pin above the threshold voltage causes the power MOSFET to switch on with a dedicated slope which is optimized for low EMC emission. [Figure 11](#) shows the timing definition.

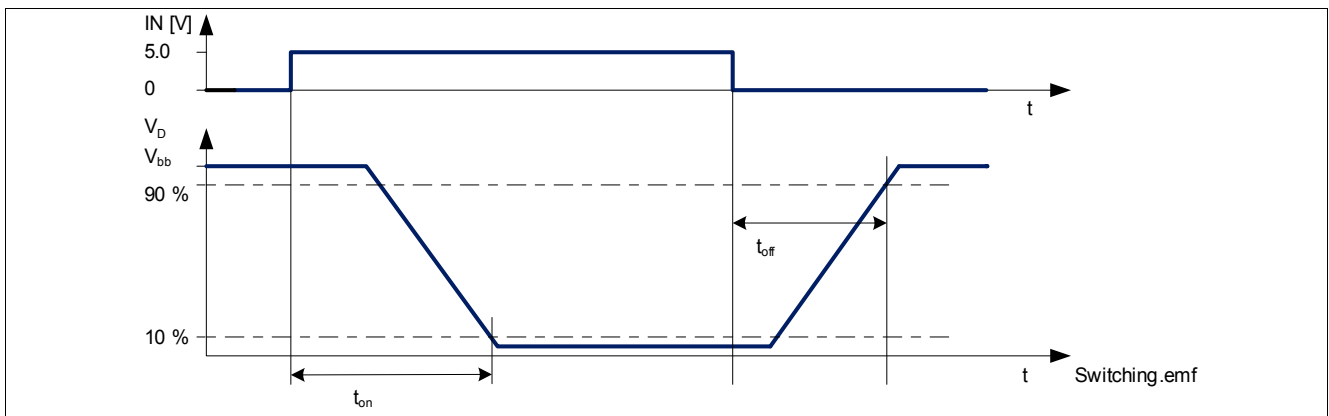

Figure 11 Definition of Power Output Timing for Resistive Load

Block Description and Characteristics Input and Power Stage
5.1.6 Characteristics

Note: Characteristics show the deviation of parameter at given input voltage and junction temperature. Typical values show the typical parameters expected from manufacturing.

All voltages with respect to Source Pin unless otherwise stated.

Electrical Characteristics: Input and Power Stage

$T_j = -40 \text{ °C}$ to $+150 \text{ °C}$, all voltages with respect to ground, positive current flowing into pin (unless otherwise specified)

Pos.	Parameter	Symbol	Limit Values			Unit	Test Conditions
			Min.	Typ.	Max.		
Input							
5.1.1	Nominal Input current	I_{INnom}	–	10	30	μA	$V_D = 0 \text{ V};$ $V_{IN} = 10 \text{ V}$
5.1.2	Input current protection mode	I_{INlim}	–	100	150	μA	$V_{IN} = 10 \text{ V};$ $T_J = 150 \text{ °C}$
5.1.3	Input threshold voltage	V_{INTH}	1.3	1.7	2.2	V	$V_D = V_{IN};$ $I_D = 50 \mu\text{A}$ $T_J = 25 \text{ °C}$
5.1.4			0.8	–	–	V	$V_D = V_{IN};$ $I_D = 50 \mu\text{A}, 150 \text{ °C}$
Power Stage							
5.1.5	On-State Resistance	$R_{DS(on)}$	–	0.9	–	Ω	¹⁾ $T_J = 25 \text{ °C};$ $V_{IN} = 5 \text{ V};$ $I_D = 200\text{mA}$
5.1.6			–	1.8	2.4	Ω	$T_J = 150 \text{ °C};$ $V_{IN} = 5 \text{ V};$ $I_D = 200\text{mA}$
5.1.7			–	0.7	–	Ω	¹⁾ $T_J = 25 \text{ °C};$ $V_{IN} = 10 \text{ V};$ $I_D = 200\text{mA}$
5.1.8			–	1.4	1.9	Ω	$T_J = 150 \text{ °C};$ $V_{IN} = 10 \text{ V};$ $I_D = 200\text{mA}$
5.1.9	Nominal load current	I_{Dnom}	350	520	–	mA	¹⁾ $T_J < 150 \text{ °C};$ $T_A = 105 \text{ °C}^{2)}$; $V_{IN} = 5 \text{ V}$
5.1.10	Zero input voltage drain current	I_{DSS}	–	–	5	μA	$V_{DS} = 13.5 \text{ V}; V_{IN} = 0 \text{ V};$ $T_J = 150 \text{ °C}$
			–	2.5	6	μA	$V_{DS} = 32 \text{ V}; V_{IN} = 0 \text{ V};$ $T_J = -40 \text{ °C}$ to 85 °C
			–	4	7	μA	$V_{DS} = 32 \text{ V}; V_{IN} = 0 \text{ V};$ $T_J = 150 \text{ °C}$

Block Description and Characteristics Input and Power Stage
Electrical Characteristics: Input and Power Stage (cont'd)

$T_j = -40 \text{ °C to } +150 \text{ °C}$, all voltages with respect to ground, positive current flowing into pin
(unless otherwise specified)

Pos.	Parameter	Symbol	Limit Values			Unit	Test Conditions
			Min.	Typ.	Max.		
Switching $V_{bb} = 12 \text{ V}$, $R_L = 82 \text{ } \Omega$							
5.1.11	Turn-on time	t_{on}	–	16	38	μs	$V_{IN} = 10 \text{ V to } 90\% I_D$
5.1.12	Turn-off time	t_{off}	–	15	45	μs	$V_{IN} = 0 \text{ V to } 10\% I_D$
5.1.13	Slew rate on	dV_{ds}/dt_{on}	–	2.5	9.3	$\text{V}/\mu\text{s}$	50% - 30% V_{bb} ; $R_L = 82 \text{ } \Omega$; $V_{IN} = 0 \text{ V to } 10 \text{ V}$; $V_{bb} = 12 \text{ V}$
5.1.14	Slew rate off	dV_{ds}/dt_{off}	–	6.0	18.2	$\text{V}/\mu\text{s}$	30% - 50% V_{bb} ; $R_L = 82 \text{ } \Omega$; $V_{IN} = 10 \text{ V to } 0 \text{ V}$; $V_{bb} = 12 \text{ V}$
Inverse Diode							
5.1.15	Inverse Diode forward voltage	V_D	–	-1.0	-1.5	V	$I_D = -1 \text{ A}$; $V_{IN} = 0 \text{ V}$

1) Not subject to production test, calculated by R_{thJA} and $R_{DS(on)}$.

2) Device mounted on PCB according EIA/JEDEC standard JESD51-7 (4-layer FR4, 76.2 mm × 114.3 mm with buried planes). PCB is mounted vertical without blown air.

6 Protection Functions

The device provides embedded protection functions. Integrated protection functions are designed to prevent IC destruction under fault conditions described in the data sheet. Fault conditions are considered as “outside” normal operation.

6.1 Thermal Protection

The device is protected against over temperature due to overload and / or bad cooling conditions. To ensure this a temperature sensor located in the Power MOSFET is used.

The BTS3205G has a thermal auto-restart function. After the device has cooled down it will switch on again see [Figure 12](#).

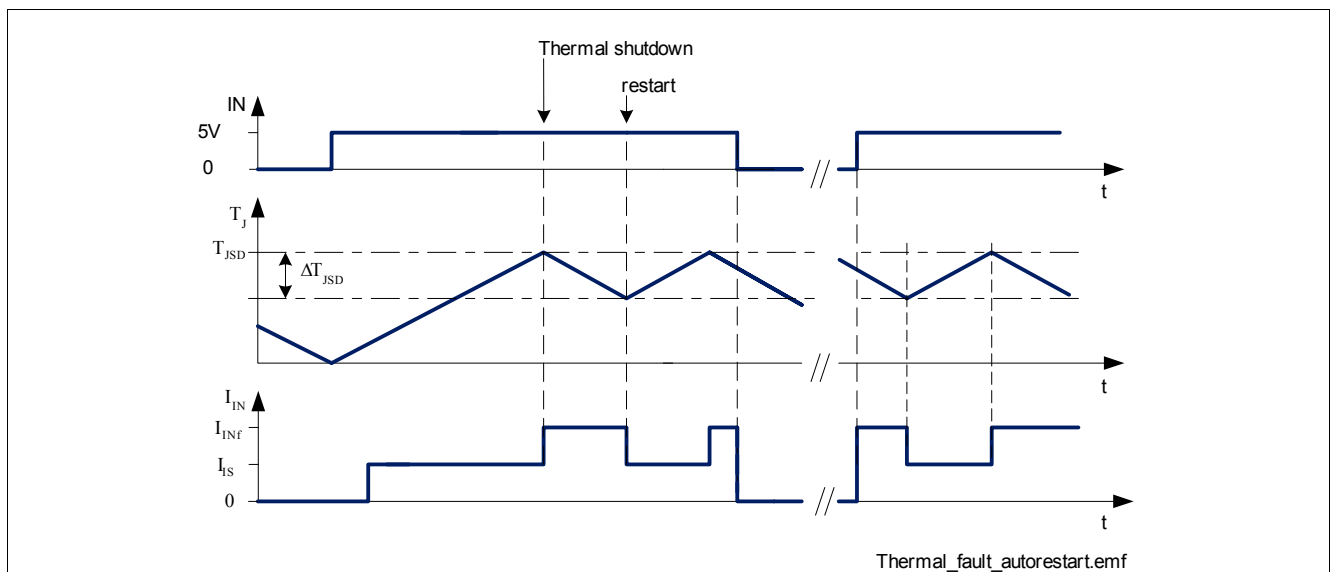

Figure 12 Error Signal via Input Current at Thermal Shutdown

6.2 Overvoltage Protection

When switching off inductive loads with low-side switches, the Drain-Source voltage V_D rises above battery potential, because the inductance intends to continue driving the current.

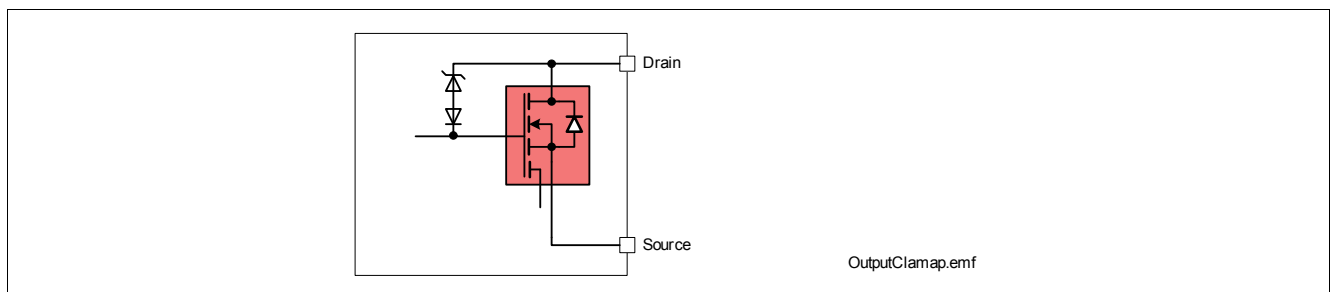

Figure 13 Output Clamp

The BTS3205G is equipped with a voltage clamp mechanism that keeps the Drain-Source voltage V_D at a certain level. See [Figure 13](#) and [Figure 14](#) for more details.

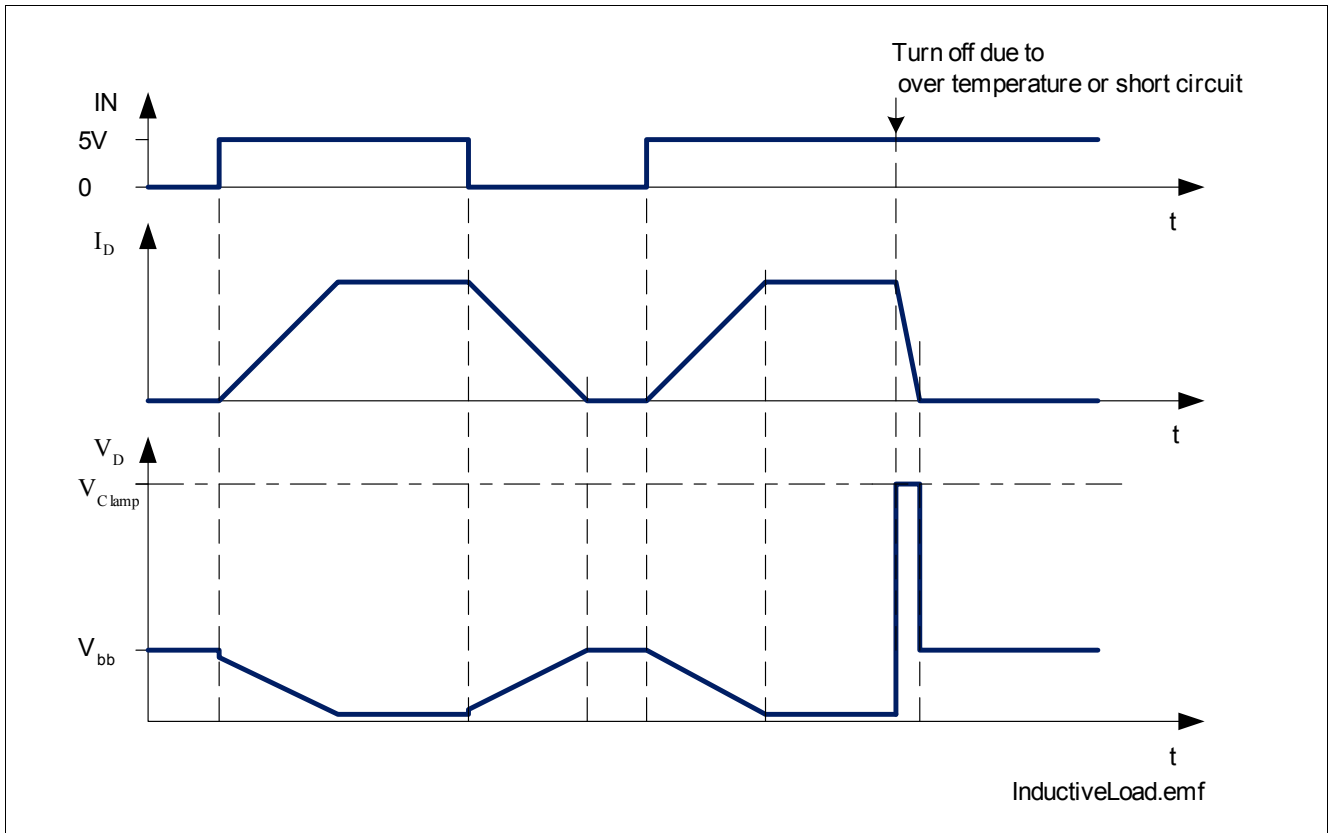

Figure 14 Switching an Inductance

While demagnetization of inductive loads, energy has to be dissipated in the BTS3205G. This energy can be calculated with following equation:

$$E = (V_{bb} + |V_{out(CL)}|) \cdot \left[\frac{|V_{out(CL)}|}{R_L} \cdot \ln \left(1 + \frac{R_L \cdot I_L}{|V_{out(CL)}|} \right) + I_L \right] \cdot \frac{L}{R_L} \quad (1)$$

Following equation simplifies under assumption of $R_L = 0$

$$E = \frac{1}{2} L I_L^2 \cdot \left(1 + \frac{V_{bb}}{|V_{out(CL)} - V_{bb}|} \right) \quad (2)$$

6.3 Short Circuit Protection

The condition short circuit is an overload condition of the device. If the current reaches the value of I_{lim} the device starts to limit the current. In the condition of current limitation the device heats up. If the thermal shutdown temperature is reached the device turns off. **Figure 15** shows this behavior. During the current limitation the input current is above I_{INnom} . During the time period t_{dlim} , the current can be above I_{lim} .

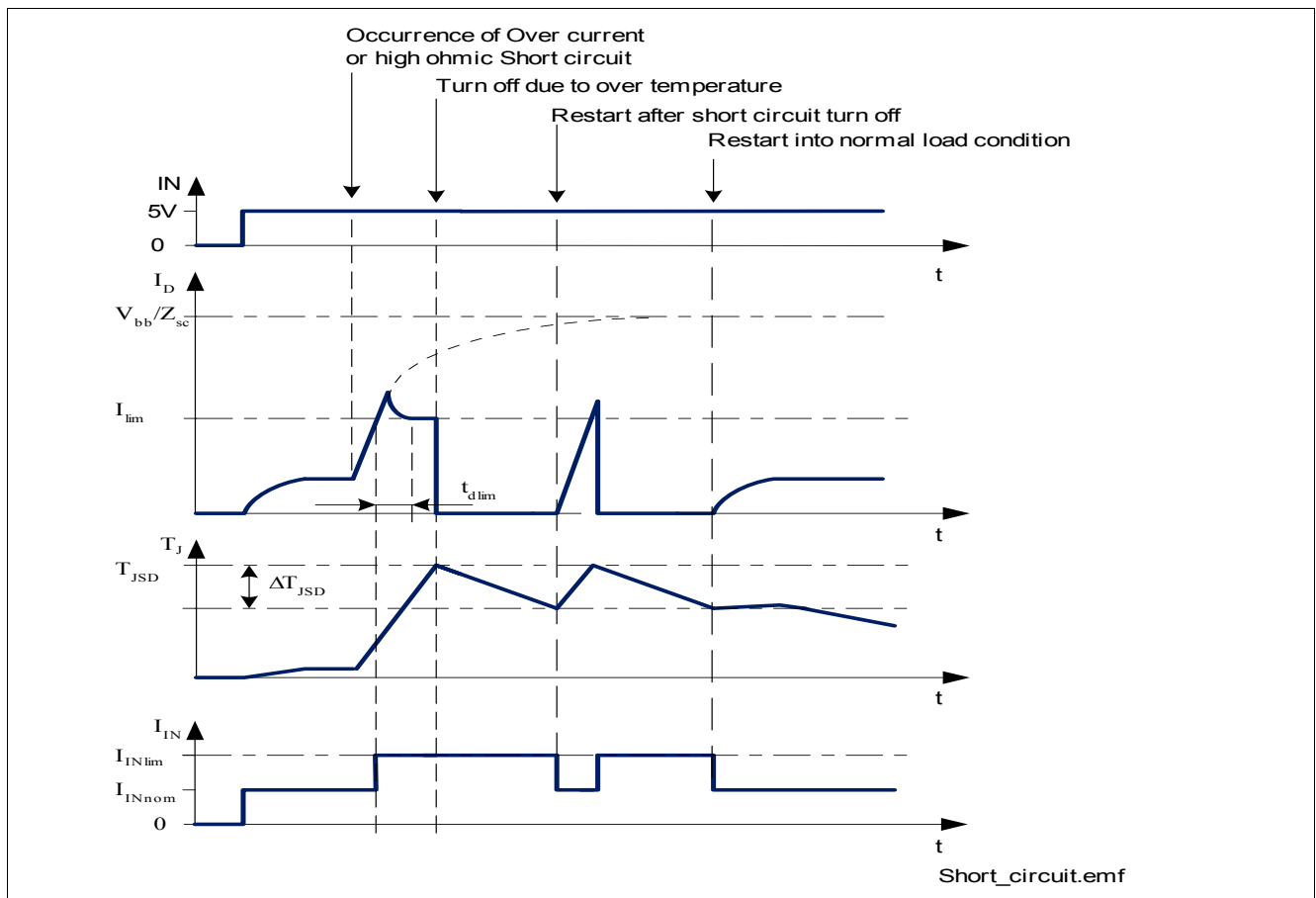

Figure 15 Short Circuit Behavior of BTS3205G

As the device is a low side switch it can be assumed that the Source to Ground path has a neglectable low impedance and resistance. Therefore all impedance and resistance in the load path during short circuit is merged into Z_{sc} .

6.4 Characteristics

Note: Characteristics show the deviation of parameter at given input voltage and junction temperature. Typical values show the typical parameters expected from manufacturing.

Electrical Characteristics: Protection Functions

$T_j = -40 \text{ °C}$ to $+150 \text{ °C}$; all voltages with respect to ground, positive current flowing into pin (unless otherwise specified)

Pos.	Parameter	Symbol	Limit Values			Unit	Test Conditions	
			Min.	Typ.	Max.			
Thermal Protection								
6.4.1	Thermal shut down junction temperature	T_{JSD}	150	175 ¹⁾	–	°C	–	
6.4.2	Thermal hysteresis	ΔT_{JSD}	–	10	–	K	¹⁾	
Overvoltage Protection								
6.4.3	Drain clamp voltage	V_{Clamp}	42	–	55	V	$V_{\text{IN}} = 0 \text{ V};$ $I_{\text{D}} = 10 \text{ mA};$	
Current Limitation and Short Circuit Protection								
6.4.4	Current limitation	I_{lim}	0.6	0.9	1.2	A	$V_{\text{IN}} = 10 \text{ V}; V_{\text{DS}} = 12 \text{ V};$ $t_{\text{measure}} = 4 \times t_{\text{dlim}}$ $T_{\text{J}} = 25 \text{ °C}^{1)}$	
			0.3	–	–			$T_{\text{J}} = 150 \text{ °C}$
			–	–	1.4			$T_{\text{J}} = -40 \text{ °C}^{1)}$
6.4.5	Current limitation delay time	t_{dlim}	–	–	50	μs	¹⁾	

1) Not subject to production test, specified by design.

7 Package Outlines BTS3205G

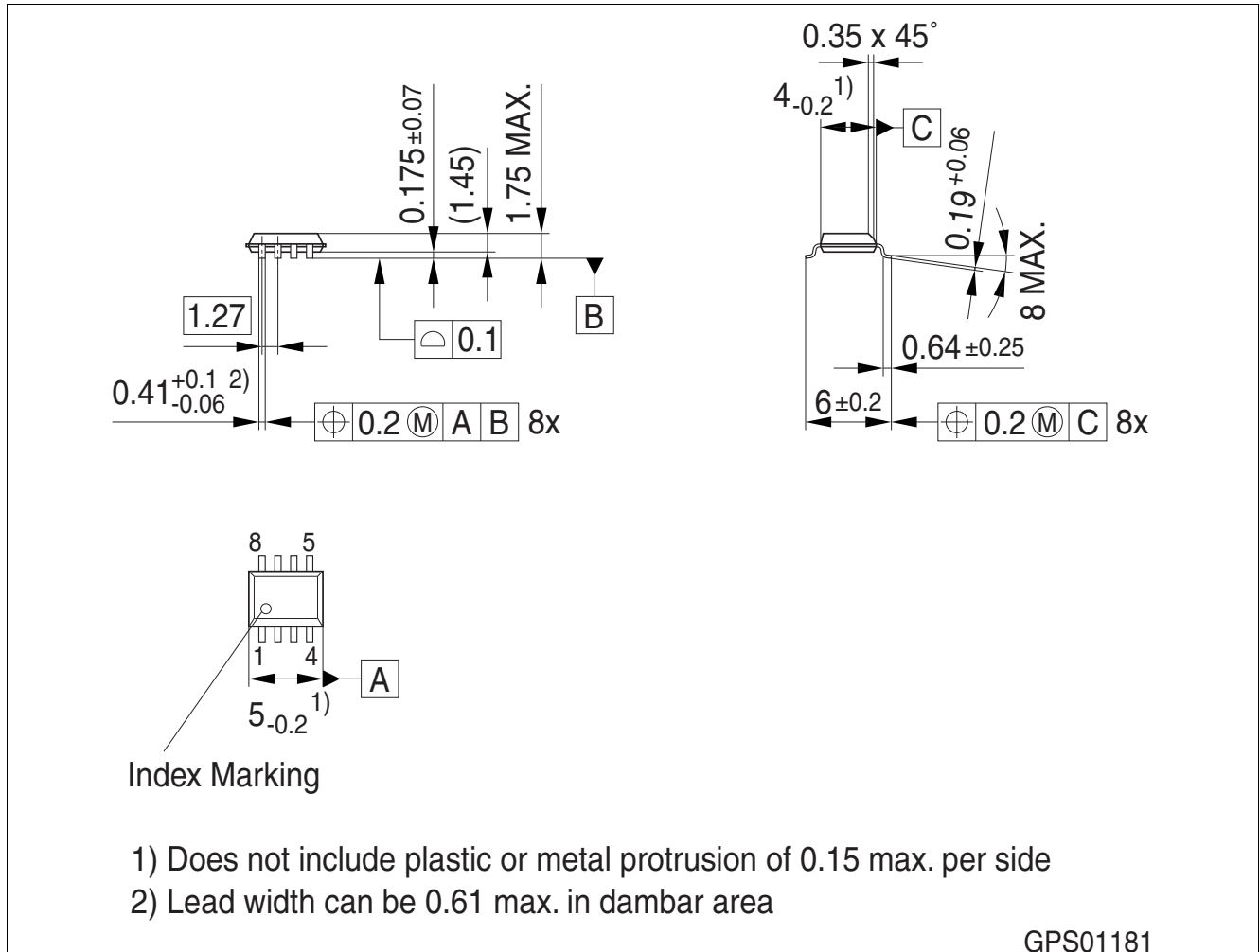

Figure 16 PG-DSO-8-24 (Plastic Dual Small Outline Package)

Green Product (RoHS compliant)

To meet the world-wide customer requirements for environmentally friendly products and to be compliant with government regulations the device is available as a green product. Green products are RoHS-Compliant (i.e. Pb-free finish on leads and suitable for Pb-free soldering according to IPC/JEDEC J-STD-020).

8 Revision History

Version	Date	Changes
Rev. 1.1	2011-09-01	fixed a typo in EAR test conditions in chapter Max ratings updated Feature list and rephrased Detailed Description fixed a spelling error in 5.1.3 regarding "dependency"
Rev. 1.0	2008-09-25	released data sheet

Edition 2011-09-01

**Published by
Infineon Technologies AG
81726 Munich, Germany**

**© 2011 Infineon Technologies AG
All Rights Reserved.**

Legal Disclaimer

The information given in this document shall in no event be regarded as a guarantee of conditions or characteristics. With respect to any examples or hints given herein, any typical values stated herein and/or any information regarding the application of the device, Infineon Technologies hereby disclaims any and all warranties and liabilities of any kind, including without limitation, warranties of non-infringement of intellectual property rights of any third party.

Information

For further information on technology, delivery terms and conditions and prices, please contact the nearest Infineon Technologies Office (www.infineon.com).

Warnings

Due to technical requirements, components may contain dangerous substances. For information on the types in question, please contact the nearest Infineon Technologies Office.

Infineon Technologies components may be used in life-support devices or systems only with the express written approval of Infineon Technologies, if a failure of such components can reasonably be expected to cause the failure of that life-support device or system or to affect the safety or effectiveness of that device or system. Life support devices or systems are intended to be implanted in the human body or to support and/or maintain and sustain and/or protect human life. If they fail, it is reasonable to assume that the health of the user or other persons may be endangered.