



Chipsmall Limited consists of a professional team with an average of over 10 year of expertise in the distribution of electronic components. Based in Hongkong, we have already established firm and mutual-benefit business relationships with customers from,Europe,America and south Asia,supplying obsolete and hard-to-find components to meet their specific needs.

With the principle of “Quality Parts,Customers Priority,Honest Operation,and Considerate Service”,our business mainly focus on the distribution of electronic components. Line cards we deal with include Microchip,ALPS,ROHM,Xilinx,Pulse,ON,Everlight and Freescale. Main products comprise IC,Modules,Potentiometer,IC Socket,Relay,Connector.Our parts cover such applications as commercial,industrial, and automotives areas.

We are looking forward to setting up business relationship with you and hope to provide you with the best service and solution. Let us make a better world for our industry!



Contact us

Tel: +86-755-8981 8866 Fax: +86-755-8427 6832

Email & Skype: info@chipsmall.com Web: www.chipsmall.com

Address: A1208, Overseas Decoration Building, #122 Zhenhua RD., Futian, Shenzhen, China



Smart Highside Power Switch

Features

- Overload protection
- Current limitation
- Short-circuit protection
- Thermal shutdown
- Overvoltage protection (including load dump)
- Fast demagnetization of inductive loads
- Reverse battery protection¹⁾
- Undervoltage and overvoltage shutdown with auto-restart and hysteresis
- Open drain diagnostic output
- Open load detection in ON-state
- CMOS compatible input
- Loss of ground and loss of V_{bb} protection²⁾
- **Electrostatic discharge (ESD)** protection

Product Summary

Overvoltage protection	$V_{bb(AZ)}$	63	V
Operating voltage	$V_{bb(on)}$	4.5 ... 42	V
On-state resistance	R_{ON}	18	m Ω
Load current (ISO)	$I_L(ISO)$	21	A
Current limitation	$I_L(SCr)$	70	A

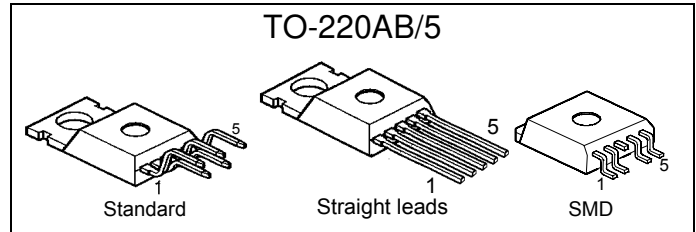

Application

- μ C compatible power switch with diagnostic feedback for 12 V and 24 V DC grounded loads
- All types of resistive, inductive and capacitive loads
- Replaces electromechanical relays and discrete circuits

General Description

N channel vertical power FET with charge pump, ground referenced CMOS compatible input and diagnostic feedback, integrated in Smart SIPMOS® chip on chip technology. Providing embedded protective functions.

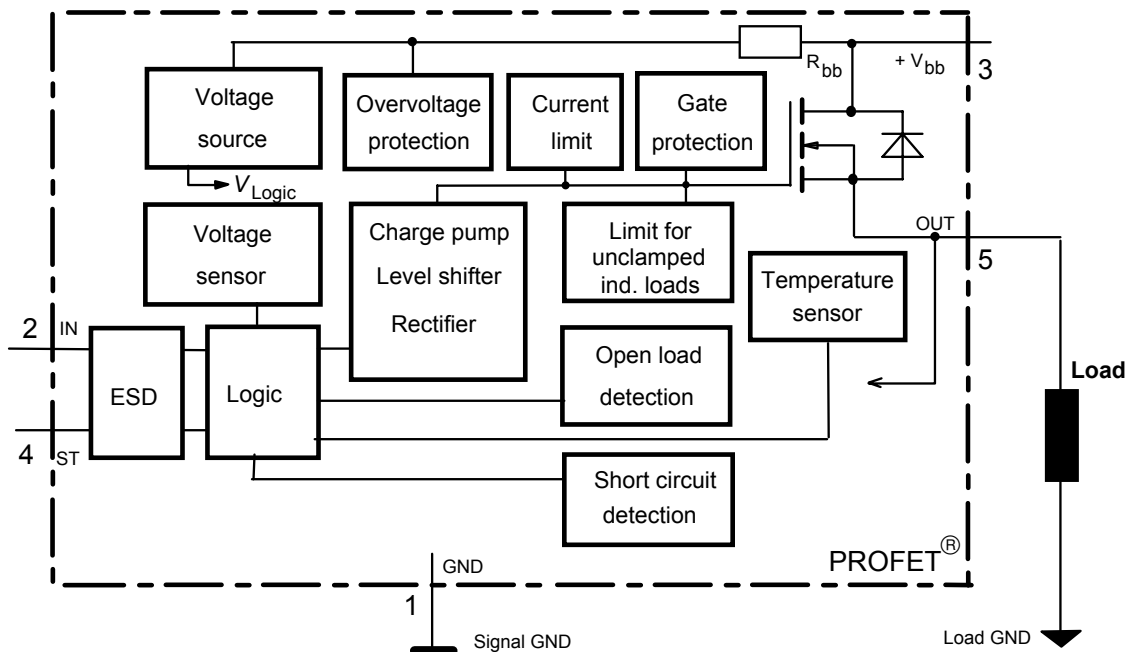

1) No external components required, reverse load current limited by connected load.

2) Additional external diode required for charged inductive loads

Pin	Symbol		Function
1	GND	-	Logic ground
2	IN	I	Input, activates the power switch in case of logical high signal
3	V _{bb}	+	Positive power supply voltage, the tab is shorted to this pin
4	ST	S	Diagnostic feedback, low on failure
5	OUT (Load, L)	O	Output to the load

Maximum Ratings at $T_j = 25\text{ °C}$ unless otherwise specified

Parameter	Symbol	Values	Unit	
Supply voltage (overvoltage protection see page 3)	V_{bb}	63	V	
Load dump protection $V_{LoadDump} = U_A + V_s$, $U_A = 13.5\text{ V}$ $R_I = 2\ \Omega$, $R_L = 1.1\ \Omega$, $t_d = 200\text{ ms}$, IN= low or high	$V_{Load\ dump}^{3)}$	80	V	
Load current (Short-circuit current, see page 4)	I_L	self-limited	A	
Operating temperature range	T_j	-40 ... +150	°C	
Storage temperature range	T_{stg}	-55 ... +150		
Power dissipation (DC)	P_{tot}	167	W	
Inductive load switch-off energy dissipation, single pulse $T_j = 150\text{ °C}$:	E_{AS}	2.1	J	
Electrostatic discharge capability (ESD) (Human Body Model)	V_{ESD}	2.0	kV	
Input voltage (DC)	V_{IN}	-0.5 ... +6	V	
Current through input pin (DC)	I_{IN}	±5.0	mA	
Current through status pin (DC) see internal circuit diagrams page 6...	I_{ST}	±5.0		
Thermal resistance	chip - case: junction - ambient (free air): SMD version, device on pcb ⁴⁾ :	R_{thJC} R_{thJA}	≤ 0.75 ≤ 75 ≤ tbd	K/W

3) $V_{Load\ dump}$ is setup without the DUT connected to the generator per ISO 7637-1 and DIN 40839

4) Device on 50mm*50mm*1.5mm epoxy PCB FR4 with 6cm² (one layer, 70µm thick) copper area for V_{bb} connection. PCB is vertical without blown air.

Electrical Characteristics

Parameter and Conditions at $T_j = 25\text{ °C}$, $V_{bb} = 12\text{ V}$ unless otherwise specified	Symbol	Values			Unit
		min	typ	max	
Load Switching Capabilities and Characteristics					
On-state resistance (pin 3 to 5) $I_L = 5\text{ A}$	$T_j = 25\text{ °C}$: $T_j = 150\text{ °C}$: R_{ON}	--	15 28	18 35	$m\Omega$
Nominal load current (pin 3 to 5) ISO Proposal: $V_{ON} = 0.5\text{ V}$, $T_C = 85\text{ °C}$	$I_{L(ISO)}$	17	21	--	A
Output current (pin 5) while GND disconnected or GND pulled up, $V_{IN} = 0$, see diagram page 7, $T_j = -40\dots+150\text{ °C}$	$I_{L(GNDhigh)}$	--	--	1	mA
Turn-on time to 90% V_{OUT} :	t_{on}	100	--	350	μs
Turn-off time to 10% V_{OUT} :	t_{off}	10	--	130	μs
$R_L = 12\ \Omega$, $T_j = -40\dots+150\text{ °C}$					
Slew rate on 10 to 30% V_{OUT} , $R_L = 12\ \Omega$, $T_j = -40\dots+150\text{ °C}$	dV/dt_{on}	0.2	--	2	$\text{V}/\mu\text{s}$
Slew rate off 70 to 40% V_{OUT} , $R_L = 12\ \Omega$, $T_j = -40\dots+150\text{ °C}$	$-dV/dt_{off}$	0.4	--	5	$\text{V}/\mu\text{s}$

Operating Parameters

Operating voltage ⁵⁾	$T_j = -40\dots+150\text{ °C}$:	$V_{bb(on)}$	4.5	--	42	V
Undervoltage shutdown	$T_j = -40\dots+150\text{ °C}$:	$V_{bb(under)}$	2.4	--	4.5	V
Undervoltage restart	$T_j = -40\dots+150\text{ °C}$:	$V_{bb(u\ rst)}$	--	--	4.5	V
Undervoltage restart of charge pump see diagram page 12	$T_j = -40\dots+150\text{ °C}$:	$V_{bb(ucp)}$	--	6.5	7.5	V
Undervoltage hysteresis $\Delta V_{bb(under)} = V_{bb(u\ rst)} - V_{bb(under)}$		$\Delta V_{bb(under)}$	--	0.2	--	V
Overshoot shutdown	$T_j = -40\dots+150\text{ °C}$:	$V_{bb(over)}$	42	--	52	V
Overshoot restart	$T_j = -40\dots+150\text{ °C}$:	$V_{bb(o\ rst)}$	42	--	--	V
Overshoot hysteresis	$T_j = -40\dots+150\text{ °C}$:	$\Delta V_{bb(over)}$	--	0.2	--	V
Overshoot protection ⁶⁾	$T_j = -40\text{ °C}$:	$V_{bb(AZ)}$	60	--	--	V
$I_{bb} = 40\text{ mA}$	$T_j = 25\dots+150\text{ °C}$:		63	67		
Standby current (pin 3) $V_{IN} = 0$	$T_j = -40\dots+25\text{ °C}$:	$I_{bb(off)}$	--	12	25	μA
	$T_j = 150\text{ °C}$:		--	18	60	
Leakage output current (included in $I_{bb(off)}$) $V_{IN} = 0$		$I_{L(off)}$	--	6	--	μA
Operating current (Pin 1) ⁷⁾ , $V_{IN} = 5\text{ V}$		I_{GND}	--	1.1	--	mA

5) At supply voltage increase up to $V_{bb} = 6.5\text{ V}$ typ without charge pump, $V_{OUT} \approx V_{bb} - 2\text{ V}$

6) see also $V_{ON(CL)}$ in table of protection functions and circuit diagram page 7. Measured without load.

7) Add I_{ST} , if $I_{ST} > 0$, add I_{IN} , if $V_{IN} > 5.5\text{ V}$

Parameter and Conditions at $T_j = 25\text{ °C}$, $V_{bb} = 12\text{ V}$ unless otherwise specified	Symbol	Values			Unit
		min	typ	max	
Protection Functions⁸⁾					
Initial peak short circuit current limit (pin 3 to 5) ⁹⁾ , (max 400 μs if $V_{ON} > V_{ON(SC)}$)	$I_{L(SCp)}$				
$T_j = -40\text{ °C}$: $T_j = 25\text{ °C}$: $T_j = +150\text{ °C}$:		-- -- 45	-- 95 --	140 -- --	A
Repetitive short circuit current limit $T_j = T_{jt}$ (see timing diagrams, page 10)	$I_{L(SCr)}$	30	70	--	A
Short circuit shutdown delay after input pos. slope $V_{ON} > V_{ON(SC)}$, min value valid only, if input "low" time exceeds 30 μs	$t_{d(SC)}$	80	--	400	μs
Output clamp (inductive load switch off) at $V_{OUT} = V_{bb} - V_{ON(CL)}$, $I_L = 30\text{ mA}$	$V_{ON(CL)}$	--	58	--	V
Short circuit shutdown detection voltage (pin 3 to 5)	$V_{ON(SC)}$	--	8.3	--	V
Thermal overload trip temperature	T_{jt}	150	--	--	°C
Thermal hysteresis	ΔT_{jt}	--	10	--	K
Inductive load switch-off energy dissipation ¹⁰⁾ , $T_{j\text{Start}} = 150\text{ °C}$, single pulse	E_{AS} E_{Load12} E_{Load24}	--	--	2.1 1.7 1.2	J
$V_{bb} = 12\text{ V}$: $V_{bb} = 24\text{ V}$:					
Reverse battery (pin 3 to 1) ¹¹⁾	$-V_{bb}$	--	--	32	V
Integrated resistor in V_{bb} line	R_{bb}	--	120	--	Ω

Diagnostic Characteristics

Open load detection current (on-condition)	$T_j = -40\text{ °C}$: $T_j = 25\text{..}150\text{ °C}$:	$I_{L(OL)}$	2 2	-- --	1900 1500	mA
-----------------------------------------------	---------------------------------------------------------------	-------------	--------	----------	--------------	----



8) Integrated protection functions are designed to prevent IC destruction under fault conditions described in the data sheet. Fault conditions are considered as "outside" normal operating range. Protection functions are not designed for continuous repetitive operation.

9) Short circuit current limit for max. duration of $t_{d(SC)\text{max}} = 400\text{ }\mu\text{s}$, prior to shutdown

10) While demagnetizing load inductance, dissipated energy in PROFET is $E_{AS} = V_{ON(CL)} * \int i_L(t) dt$, approx.

$$E_{AS} = \frac{1}{2} * L * I_L^2 * \left(\frac{V_{ON(CL)}}{V_{ON(CL)} - V_{bb}} \right), \text{ see diagram page 8}$$

11) Reverse load current (through intrinsic drain-source diode) is normally limited by the connected load. Reverse current I_{GND} of $\approx 0.3\text{ A}$ at $V_{bb} = -32\text{ V}$ through the logic heats up the device. Time allowed under these condition is dependent on the size of the heatsink. Reverse I_{GND} can be reduced by an additional external GND-resistor (150 Ω). Input and Status currents have to be limited (see max. ratings page 2 and circuit page 7).

Parameter and Conditions at $T_j = 25\text{ °C}$, $V_{bb} = 12\text{ V}$ unless otherwise specified	Symbol	Values			Unit
		min	typ	max	
Input and Status Feedback¹²⁾					
Input turn-on threshold voltage  $T_j = -40\dots+150\text{ °C}$:	$V_{IN(T+)}$	1.5	--	2.4	V
Input turn-off threshold voltage  $T_j = -40\dots+150\text{ °C}$:	$V_{IN(T-)}$	1.0	--	--	V
Input threshold hysteresis	$\Delta V_{IN(T)}$	--	0.5	--	V
Off state input current (pin 2), $V_{IN} = 0.4\text{ V}$	$I_{IN(off)}$	1	--	30	μA
On state input current (pin 2), $V_{IN} = 3.5\text{ V}$	$I_{IN(on)}$	10	25	50	μA
Status invalid after positive input slope (short circuit) $T_j = -40\dots+150\text{ °C}$:	$t_{d(ST\ SC)}$	80	200	400	μs
Status invalid after positive input slope (open load) $T_j = -40\dots+150\text{ °C}$:	$t_{d(ST)}$	350	--	1600	μs
Status output (open drain)					
Zener limit voltage $T_j = -40\dots+150\text{ °C}$, $I_{ST} = +1.6\text{ mA}$:	$V_{ST(high)}$	5.4	6.1	--	V
ST low voltage $T_j = -40\dots+150\text{ °C}$, $I_{ST} = +1.6\text{ mA}$:	$V_{ST(low)}$	--	--	0.4	

¹²⁾ If a ground resistor R_{GND} is used, add the voltage drop across this resistor.

Truth Table

	Input-level	Output level	Status	
			442 D2	442 E2
Normal operation	L	L	H	H
	H	H	H	H
Open load	L	13)	H	H
	H	H	L	L
Short circuit to GND	L	L	H	H
	H	L	L	L
Short circuit to V _{bb}	L	H	H	H
	H	H	H (L ¹⁴)	H (L ¹⁴)
Overtemperature	L	L	L	L
	H	L	L	L
Under-voltage	L	L	L ¹⁵⁾	H
	H	L	L ¹⁵⁾	H
Overvoltage	L	L	L	H
	H	L	L	H

L = "Low" Level
H = "High" Level

Terms

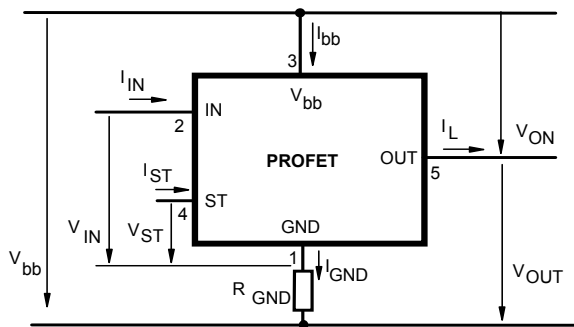

Input circuit (ESD protection)

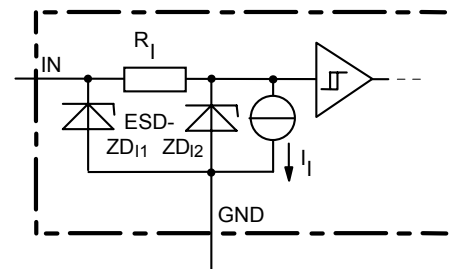

ZD11 6.1 V typ., ESD zener diodes are not to be used as voltage clamp at DC conditions. Operation in this mode may result in a drift of the zener voltage (increase of up to 1 V).

- 13) Power Transistor off, high impedance
- 14) Low resistance short V_{bb} to output may be detected by no-load-detection
- 15) No current sink capability during undervoltage shutdown

Status output

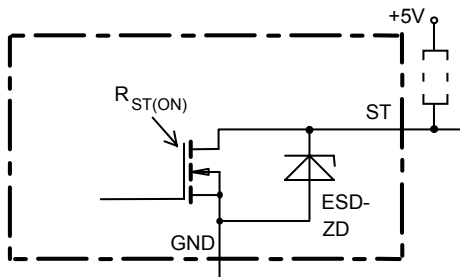

ESD-Zener diode: 6.1 V typ., max 5 mA;
 $R_{ST(ON)} < 250 \Omega$ at 1.6 mA, ESD zener diodes are not to be used as voltage clamp at DC conditions.
 Operation in this mode may result in a drift of the zener voltage (increase of up to 1 V).

Short Circuit detection

Fault Condition: $V_{ON} > 8.3 \text{ V typ.};$ IN high

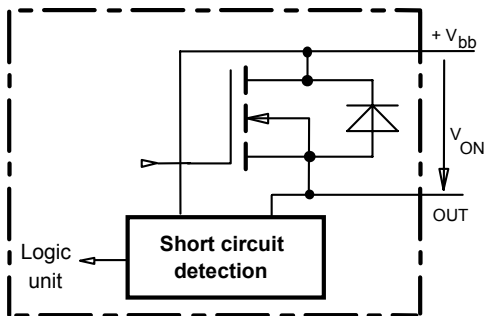

Inductive and overvoltage output clamp

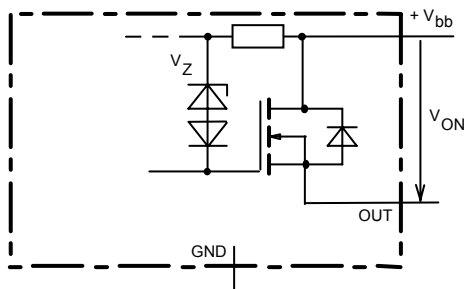

V_{ON} clamped to 58 V typ.

Overvolt. and reverse batt. protection

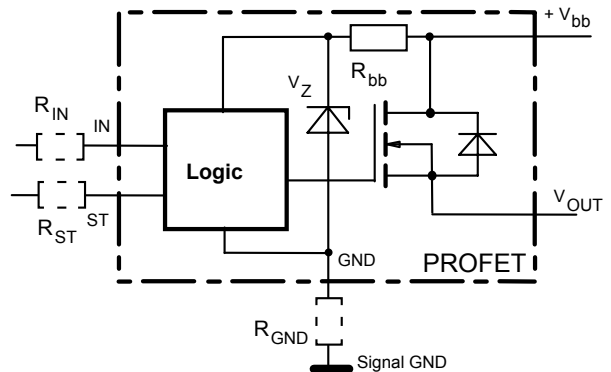

$R_{bb} = 120 \Omega$ typ., $V_Z + R_{bb} * 40 \text{ mA} = 67 \text{ V typ.}$, add R_{GND} , R_{IN} , R_{ST} for extended protection

Open-load detection

ON-state diagnostic condition: $V_{ON} < R_{ON} * I_{L(OL)};$ IN high

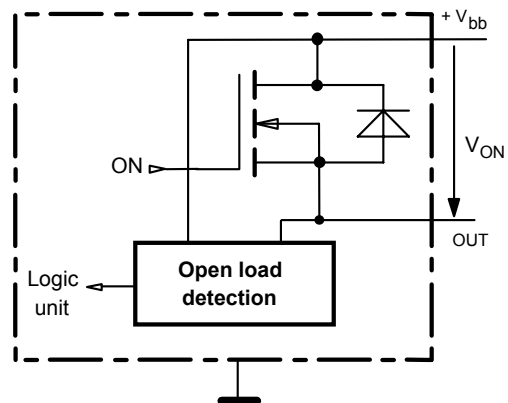

GND disconnect

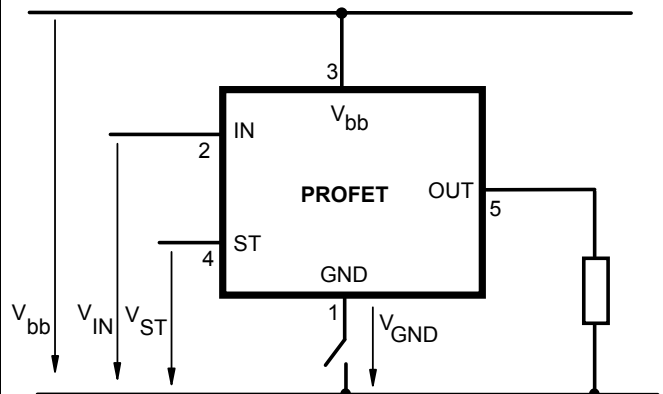

Any kind of load. In case of Input=high is $V_{OUT} \approx V_{IN} - V_{IN(T+)}.$
 Due to $V_{GND} > 0$, no $V_{ST} = \text{low}$ signal available.

GND disconnect with GND pull up

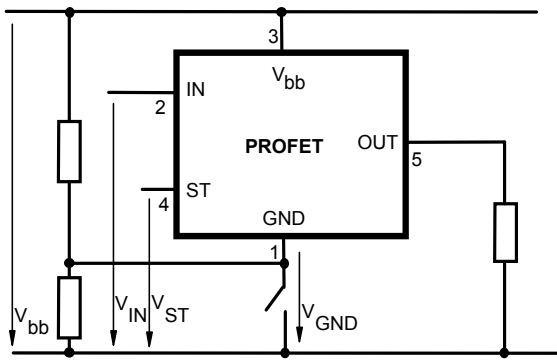

Any kind of load. If $V_{GND} > V_{IN} - V_{IN(T+)}$ device stays off
 Due to $V_{GND} > 0$, no V_{ST} = low signal available.

Vbb disconnect with charged inductive load

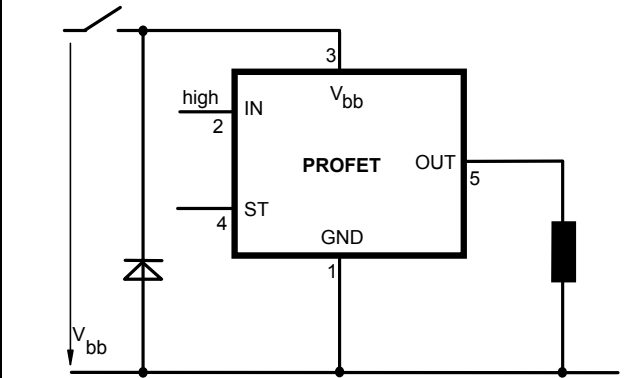
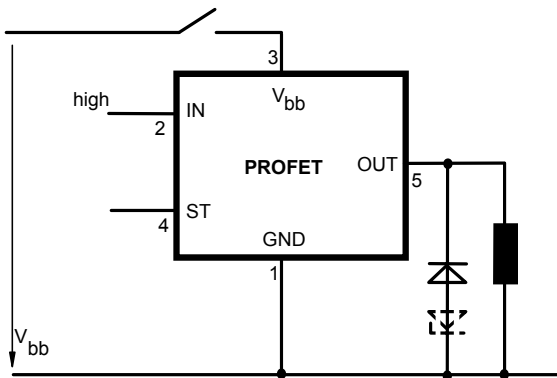

Inductive Load switch-off energy dissipation

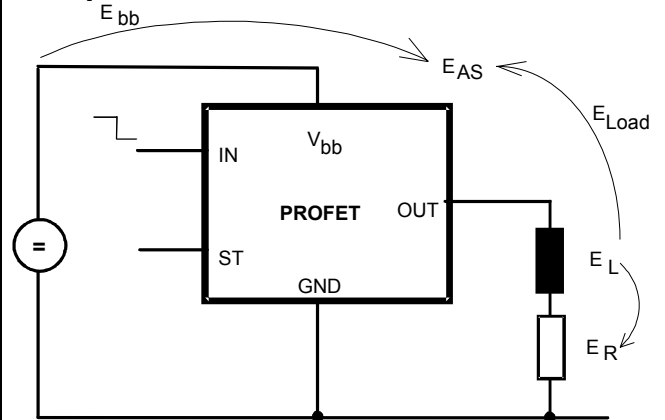

Energy dissipated in PROFET $E_{AS} = E_{bb} + E_L - E_R$.
 $E_{Load} < E_L$, $E_L = 1/2 * L * I_L^2$

Options Overview

all versions: High-side switch, Input protection, ESD protection, load dump and reverse battery protection , protection against loss of ground

Type	BTS	442D2	442E2
Logic version		D	E
Overtemperature protection $T_j > 150\text{ °C}$, latch function ¹⁶⁾¹⁷⁾ $T_j > 150\text{ °C}$, with auto-restart on cooling		X	X
Short-circuit to GND protection switches off when $V_{ON} > 8.3\text{ V}$ typ. ¹⁶⁾ (when first turned on after approx. 200 μs)		X	X
Open load detection in OFF-state with sensing current 30 μA typ. in ON-state with sensing voltage drop across power transistor		X	X
Undervoltage shutdown with auto restart		X	X
Overvoltage shutdown with auto restart		X	X
Status feedback for			
overtemperature		X	X
short circuit to GND		X	X
short to V_{bb}		- ¹⁸⁾	- ¹⁸⁾
open load		X	X
undervoltage		X	-
overvoltage		X	-
Status output type			
CMOS		X	
Open drain			X
Output negative voltage transient limit (fast inductive load switch off)			
to $V_{bb} - V_{ON(CL)}$		X	X
Load current limit			
high level (can handle loads with high inrush currents)		X	X
medium level			
low level (better protection of application)			

¹⁶⁾ Latch except when $V_{bb} - V_{OUT} < V_{ON(SC)}$ after shutdown. In most cases $V_{OUT} = 0\text{ V}$ after shutdown ($V_{OUT} \neq 0\text{ V}$ only if forced externally). So the device remains latched unless $V_{bb} < V_{ON(SC)}$ (see page 4). No latch between turn on and $t_{d(SC)}$.

¹⁷⁾ With latch function. Reseted by a) Input low, b) Undervoltage, c) Overvoltage

¹⁸⁾ Low resistance short V_{bb} to output may be detected by no-load-detection

Timing diagrams

Figure 1a: V_{bb} turn on:

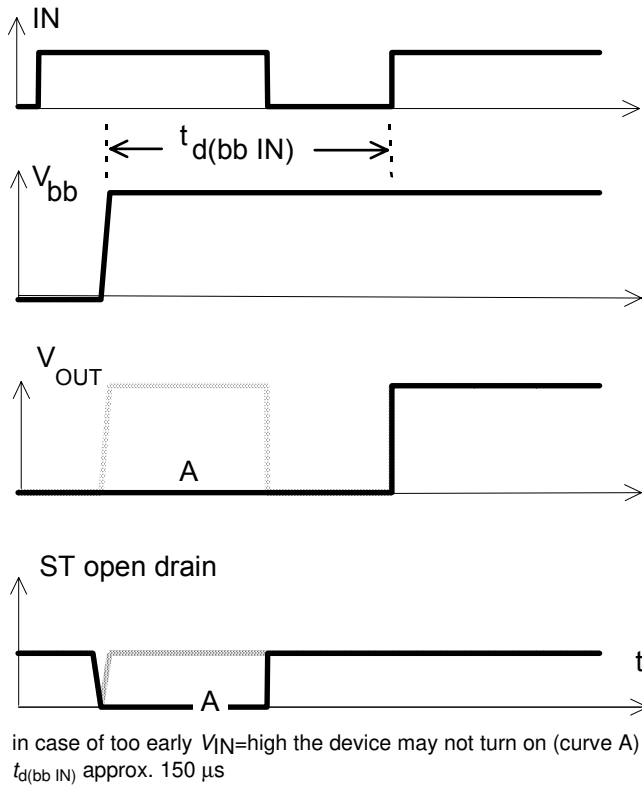

Figure 2a: Switching a lamp,

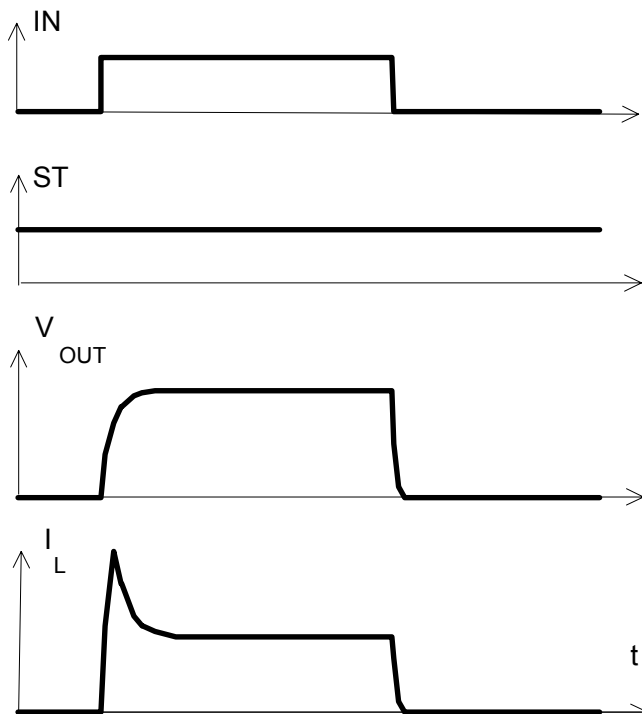
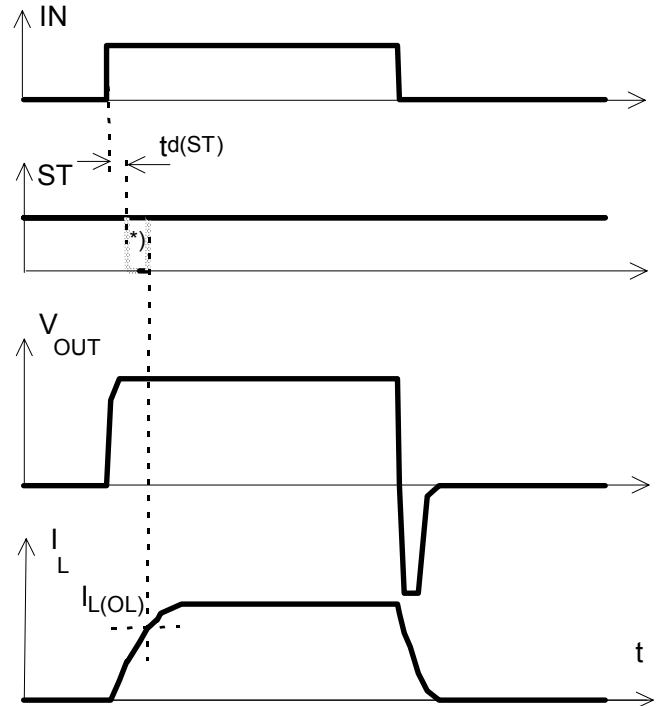

Figure 2b: Switching an inductive load



*) if the time constant of load is too large, open-load-status may occur

Figure 3a: Turn on into short circuit,

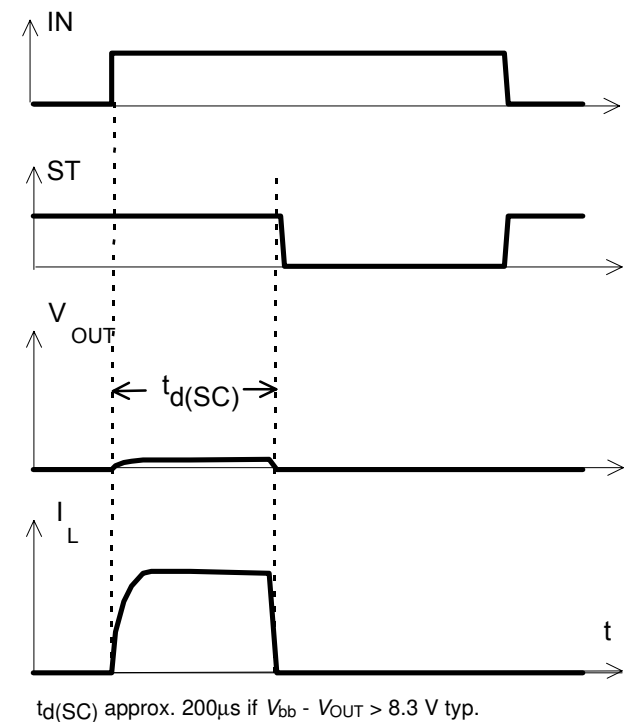
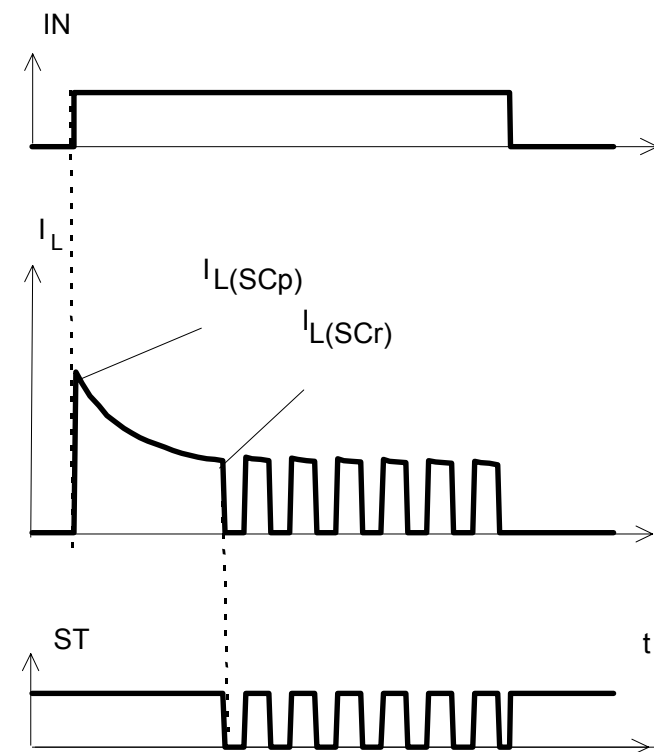
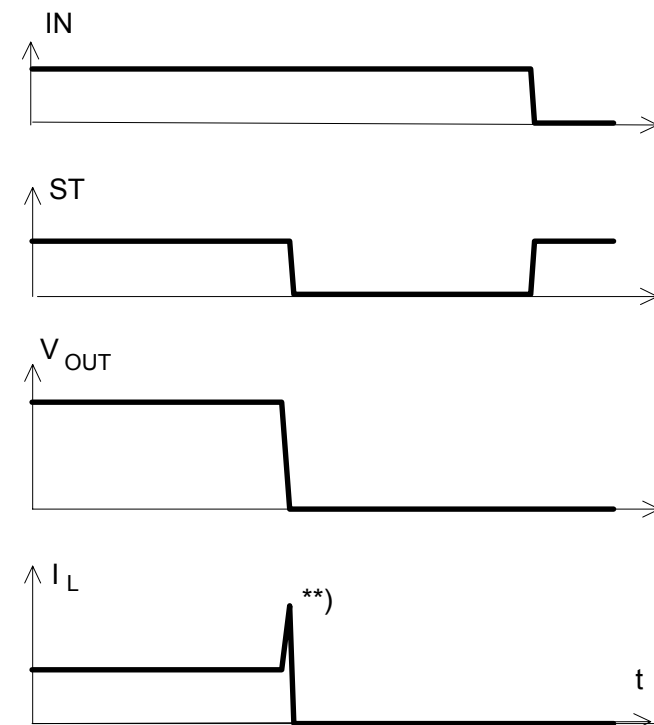

Figure 3b: Turn on into overload,



Heating up may require several milliseconds,
 $V_{bb} - V_{OUT} < 8.3$ V typ.

Figure 3c: Short circuit while on:



***) current peak approx. 20 μ s

Figure 4a: Overtemperature:
 Reset if $T_j < T_{jt}$

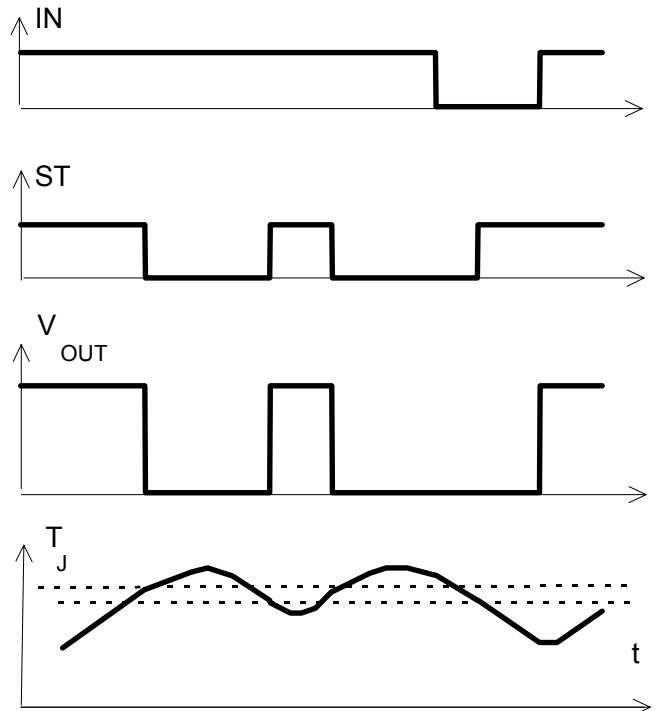

Figure 5a: Open load: detection in ON-state, turn on/off to open load

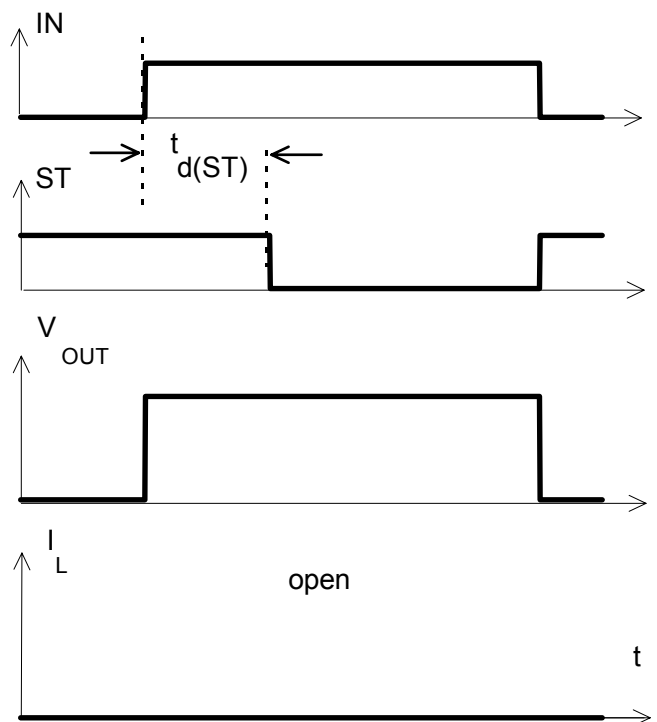

Figure 5b: Open load: detection in ON-state, open load occurs in on-state

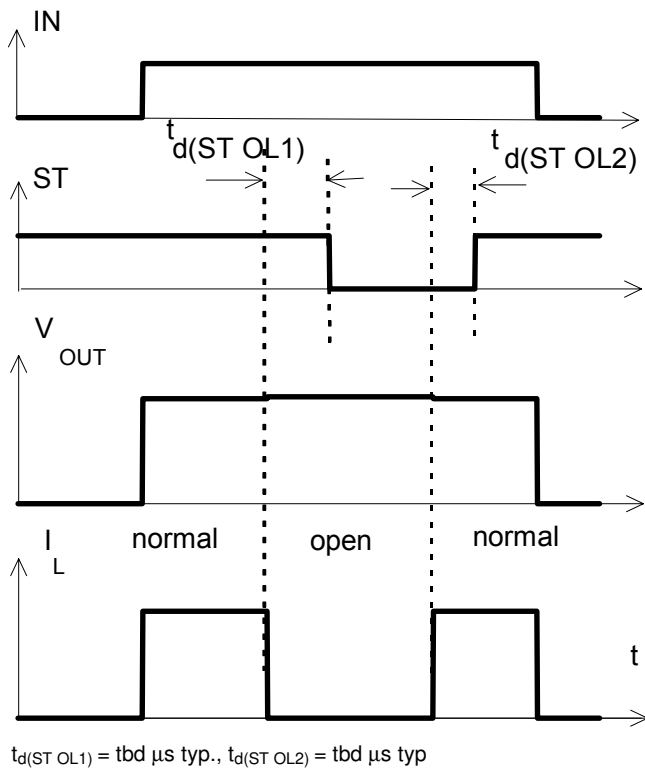

Figure 6a: Undervoltage:

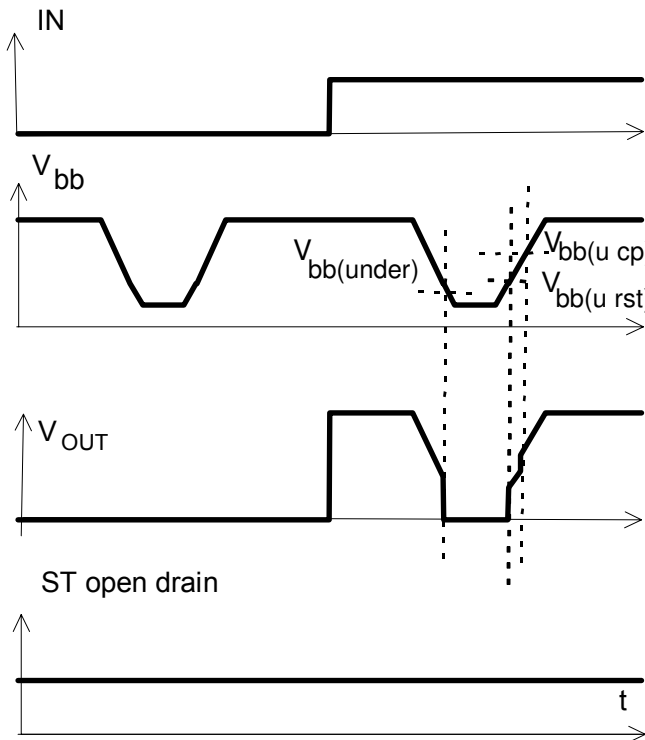

Figure 6b: Undervoltage restart of charge pump

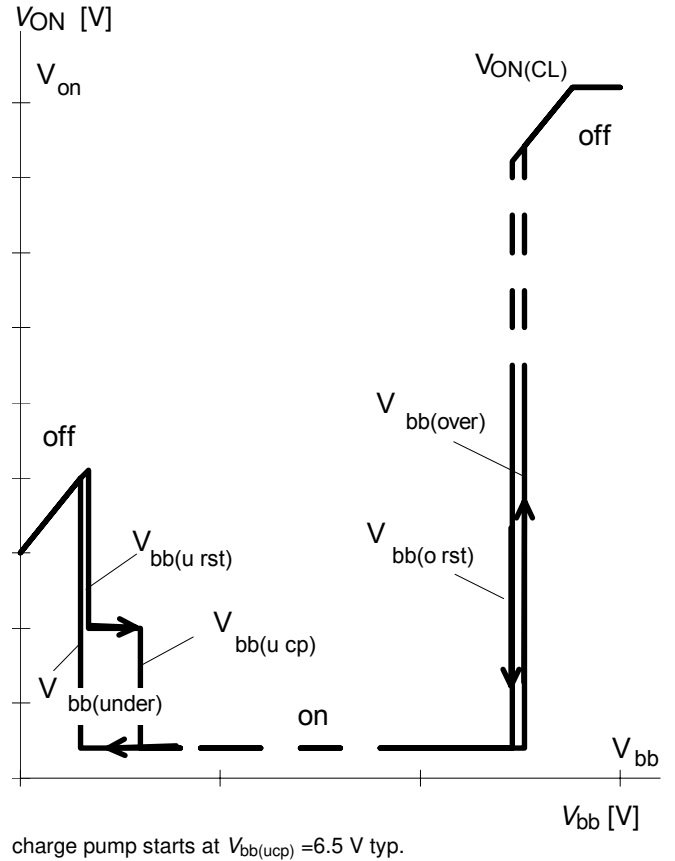
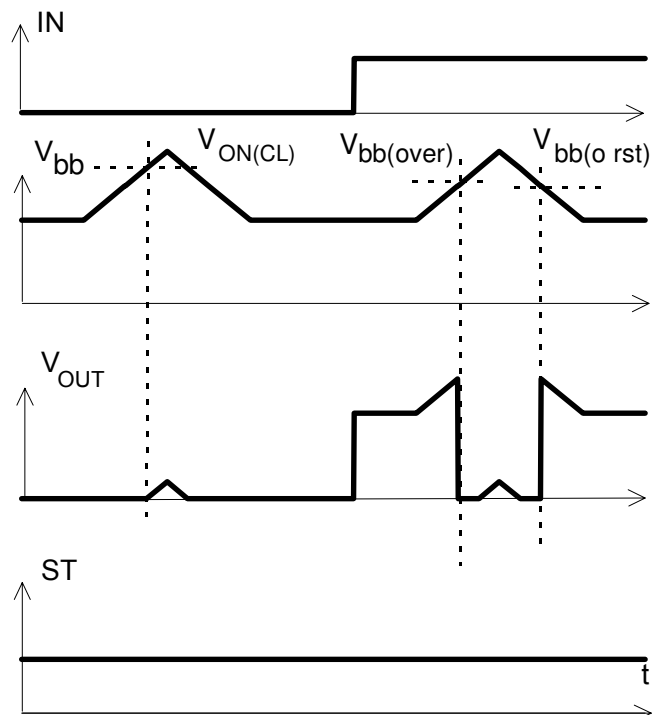

Figure 7a: Overvoltage:



Package and Ordering Code

All dimensions in mm

Standard TO-220AB/5

Ordering code

BTS 442 E2	Q67060-S6206-A2
------------	-----------------

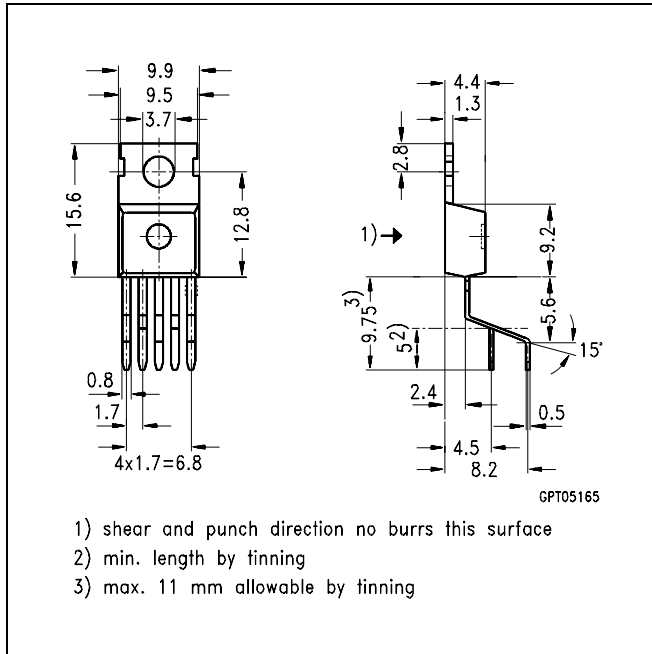

TO-220AB/5, Option E3043 Ordering code

BTS 442 E2 E3043	Q67060-S6206-A3
------------------	-----------------

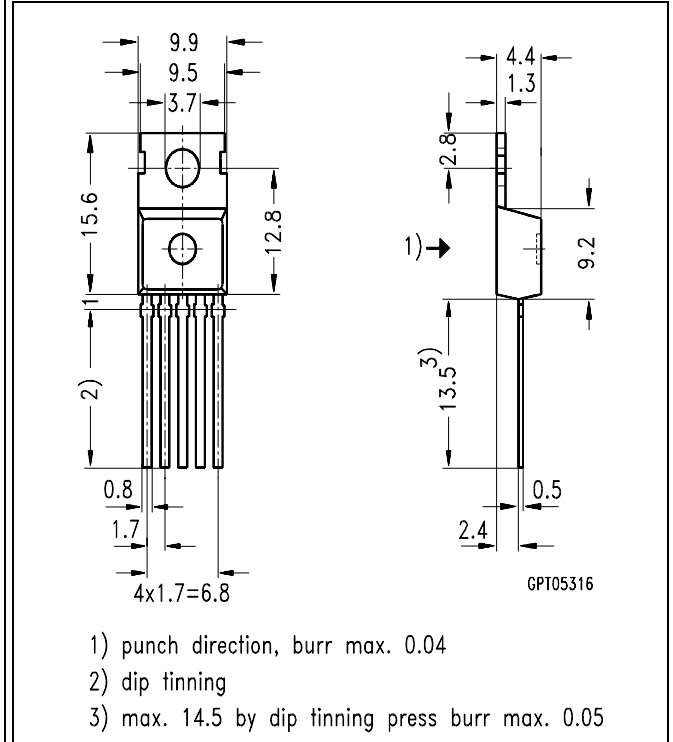

SMD TO-220AB/5, Opt. E3062 Ordering code

BTS442E2 E3062A	T&R: Q67060-S6206-A4
-----------------	----------------------

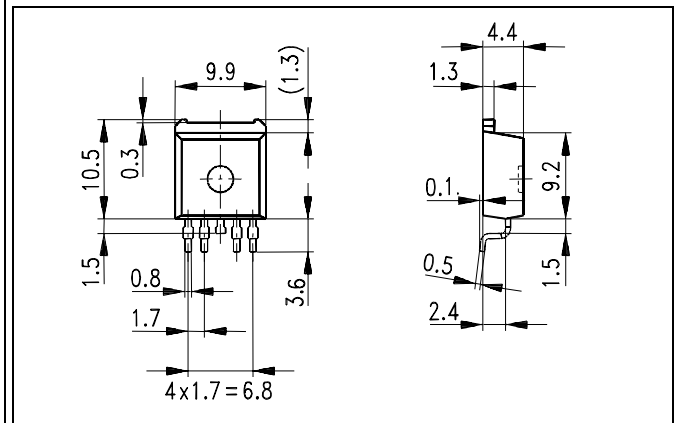

Published by
Infineon Technologies AG,
St.-Martin-Strasse 53,
D-81669 München
© Infineon Technologies AG 2001
All Rights Reserved.

Attention please!

The information herein is given to describe certain components and shall not be considered as a guarantee of characteristics.

Terms of delivery and rights to technical change reserved.

We hereby disclaim any and all warranties, including but not limited to warranties of non-infringement, regarding circuits, descriptions and charts stated herein.

Infineon Technologies is an approved CECC manufacturer.

Information

For further information on technology, delivery terms and conditions and prices please contact your nearest Infineon Technologies Office in Germany or our Infineon Technologies Representatives worldwide (see address list).

Warnings

Due to technical requirements components may contain dangerous substances. For information on the types in question please contact your nearest Infineon Technologies Office.

Infineon Technologies Components may only be used in life-support devices or systems with the express written approval of Infineon Technologies, if a failure of such components can reasonably be expected to cause the failure of that life-support device or system, or to affect the safety or effectiveness of that device or system. Life support devices or systems are intended to be implanted in the human body, or to support and/or maintain and sustain and/or protect human life. If they fail, it is reasonable to assume that the health of the user or other persons may be endangered.