



Chipsmall Limited consists of a professional team with an average of over 10 year of expertise in the distribution of electronic components. Based in Hongkong, we have already established firm and mutual-benefit business relationships with customers from,Europe,America and south Asia,supplying obsolete and hard-to-find components to meet their specific needs.

With the principle of “Quality Parts,Customers Priority,Honest Operation,and Considerate Service”,our business mainly focus on the distribution of electronic components. Line cards we deal with include Microchip,ALPS,ROHM,Xilinx,Pulse,ON,Everlight and Freescale. Main products comprise IC,Modules,Potentiometer,IC Socket,Relay,Connector.Our parts cover such applications as commercial,industrial, and automotives areas.

We are looking forward to setting up business relationship with you and hope to provide you with the best service and solution. Let us make a better world for our industry!



## Contact us

Tel: +86-755-8981 8866 Fax: +86-755-8427 6832

Email & Skype: info@chipsmall.com Web: www.chipsmall.com

Address: A1208, Overseas Decoration Building, #122 Zhenhua RD., Futian, Shenzhen, China





## Smart Highside High Current Power Switch

### Reversave™

- Reverse battery protection by self turn on of power MOSFET

### Features

- Overload protection
- Current limitation
- Short circuit protection
- Over temperature protection
- Over voltage protection (including load dump)
- Clamp of negative voltage at output
- Fast deenergizing of inductive loads <sup>1)</sup>
- Low ohmic inverse current operation
- Diagnostic feedback with load current sense
- Open load detection via current sense
- Loss of  $V_{bb}$  protection<sup>2)</sup>
- **Electrostatic discharge (ESD)** protection
- Green product (RoHS compliant)
- AEC qualified

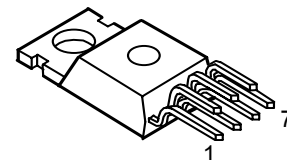
### Application

- Power switch with current sense diagnostic feedback for up to 48V DC grounded loads
- Most suitable for loads with high inrush current like lamps and motors; all types of resistive and inductive loads
- Replaces electromechanical relays, fuses and discrete circuits

### Product Summary

Overvoltage protection	$V_{bb(AZ)}$	70	V
Output clamp	$V_{ON(CL)}$	62	V
Operating voltage	$V_{bb(on)}$	5.0 ... 58	V
On-state resistance	$R_{ON}$	9	mΩ
Load current (ISO)	$I_L(ISO)$	44	A
Short circuit current limitation	$I_L(SC)$	90	A
Current sense ratio	$I_L : I_{IS}$	13 000	

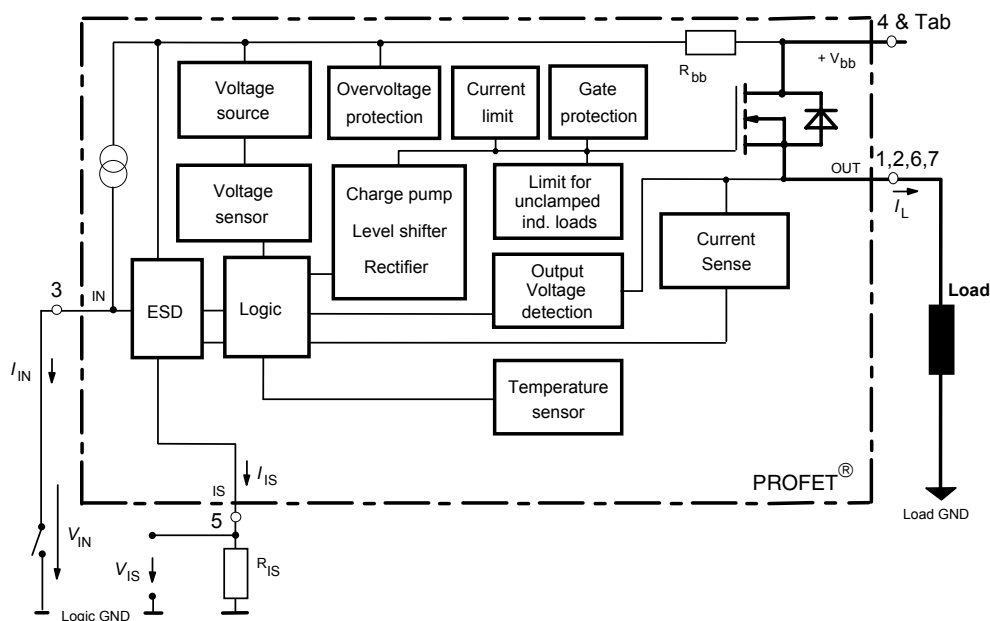
PG-TO220-7-11



Standard

### General Description

N channel vertical power FET with charge pump, current controlled input and diagnostic feedback with load current sense, integrated in Smart SIPMOS® chip on chip technology. Providing embedded protection functions.



<sup>1)</sup> With additional external diode.

<sup>2)</sup> Additional external diode required for energized inductive loads (see page 9).

Pin	Symbol		Function
1	OUT	O	Output to the load. The pins 1,2,6 and 7 must be shorted with each other especially in high current applications! <sup>3)</sup>
2	OUT	O	Output to the load. The pins 1,2,6 and 7 must be shorted with each other especially in high current applications! <sup>3)</sup>
3	IN	I	Input, activates the power switch in case of short to ground
4	V <sub>bb</sub>	+	Positive power supply voltage, the tab is electrically connected to this pin. In high current applications the tab should be used for the V <sub>bb</sub> connection instead of this pin <sup>4)</sup> .
5	IS	S	Diagnostic feedback providing a sense current proportional to the load current; zero current on failure (see Truth Table on page 7)
6	OUT	O	Output to the load. The pins 1,2,6 and 7 must be shorted with each other especially in high current applications! <sup>3)</sup>
7	OUT	O	Output to the load. The pins 1,2,6 and 7 must be shorted with each other especially in high current applications! <sup>3)</sup>

**Maximum Ratings** at  $T_j = 25\text{ °C}$  unless otherwise specified

Parameter	Symbol	Values	Unit
Supply voltage (over voltage protection see page 4)	V <sub>bb</sub>	62	V
Supply voltage for full short circuit protection, (E <sub>AS</sub> limitation see diagram on page 10) $T_{j,start} = -40 \dots +150\text{ °C}$ :	V <sub>bb</sub>	58	V
Load current (short circuit current, see page 5)	I <sub>L</sub>	self-limited	A
Load dump protection $V_{LoadDump} = U_A + V_S$ , $U_A = 13.5\text{ V}$ $R_i^{5)} = 2\ \Omega$ , $R_L = 0.23\ \Omega$ , $t_d = 200\text{ ms}$ , IN, IS = open or grounded	V <sub>Load dump</sub> <sup>6)</sup>	80	V
Operating temperature range	T <sub>j</sub>	-40 ...+150	°C
Storage temperature range	T <sub>stg</sub>	-55 ...+150	
Power dissipation (DC), T <sub>C</sub> ≤ 25 °C	P <sub>tot</sub>	170	W
Inductive load switch-off energy dissipation, single pulse V <sub>bb</sub> = 12V, T <sub>j,start</sub> = 150°C, T <sub>C</sub> = 150°C const., I <sub>L</sub> = 20 A, Z <sub>L</sub> = 6 mH, 0 Ω, see diagrams on page 10	E <sub>AS</sub>	1.2	J
Electrostatic discharge capability (ESD) Human Body Model acc. MIL-STD883D, method 3015.7 and ESD assn. std. S5.1-1993, C = 100 pF, R = 1.5 kΩ	V <sub>ESD</sub>	4.0	kV
Current through input pin (DC)	I <sub>IN</sub>	+15, -250	mA
Current through current sense status pin (DC) see internal circuit diagrams on page 7 and 8	I <sub>IS</sub>	+15, -250	

<sup>3)</sup> Not shorting all outputs will considerably increase the on-state resistance, reduce the peak current capability and decrease the current sense accuracy

<sup>4)</sup> Otherwise add up to 0.7 mΩ (depending on used length of the pin) to the R<sub>ON</sub> if the pin is used instead of the tab.

<sup>5)</sup> R<sub>i</sub> = internal resistance of the load dump test pulse generator.

<sup>6)</sup> V<sub>Load dump</sub> is setup without the DUT connected to the generator per ISO 7637-1 and DIN 40839.



**Thermal Characteristics**

Parameter and Conditions	Symbol	Values			Unit
		min	typ	max	
Thermal resistance chip - case: junction - ambient (free air): SMD version, device on PCB <sup>8)</sup> :	$R_{thJC}$ <sup>7)</sup>	--	--	0.75	K/W
	$R_{thJA}$	--	60	--	
	$R_{thJA}$	--	33	--	

**Electrical Characteristics**

Parameter and Conditions	Symbol	Values			Unit
		min	typ	max	
at $T_j = -40 \dots +150^\circ\text{C}$ , $V_{bb} = 24\text{V}$ unless otherwise specified					

**Load Switching Capabilities and Characteristics**

On-state resistance (Tab to pins 1,2,6,7, see measurement circuit page 7) $I_L = 20\text{A}$ , $T_j = 25^\circ\text{C}$ : $V_{IN} = 0$ , $I_L = 20\text{A}$ , $T_j = 150^\circ\text{C}$ : $I_L = 80\text{A}$ , $T_j = 150^\circ\text{C}$ : $V_{bb} = 6\text{V}$ , $I_L = 20\text{A}$ , $T_j = 150^\circ\text{C}$ :	$R_{ON}$   $R_{ON(Static)}$	--	7.2 14.6 --	9 17 17	m $\Omega$
Nominal load current <sup>9)</sup> (Tab to pins 1,2,6,7) ISO 10483-1/6.7: $V_{ON} = 0.5\text{V}$ , $T_C = 85^\circ\text{C}$ <sup>10)</sup>	$I_{L(ISO)}$	38	44	--	A
Nominal load current <sup>9)</sup> , device on PCB <sup>8)</sup> $T_A = 85^\circ\text{C}$ , $T_j \leq 150^\circ\text{C}$ $V_{ON} \leq 0.5\text{V}$ ,	$I_{L(NOM)}$	9.9	11.1	--	A
Maximum load current in resistive range (Tab to pins 1,2,6,7) $V_{ON} = 1.8\text{V}$ , $T_C = 25^\circ\text{C}$ : see diagram on page 13 $V_{ON} = 1.8\text{V}$ , $T_C = 150^\circ\text{C}$ :	$I_{L(Max)}$	185 105	-- --	-- --	A
Turn-on time <sup>11)</sup> $I_{IN}$  to 90% $V_{OUT}$ :	$t_{on}$	50	--	400	$\mu\text{s}$
Turn-off time $I_{IN}$  to 10% $V_{OUT}$ : $R_L = 1\Omega$ , $T_j = -40 \dots +150^\circ\text{C}$	$t_{off}$	30	--	110	$\mu\text{s}$
Slew rate on <sup>11)</sup> (10 to 30% $V_{OUT}$ ) $R_L = 1\Omega$	$dV/dt_{on}$	1.0	1.5	2.2	V/ $\mu\text{s}$
Slew rate off <sup>11)</sup> (70 to 40% $V_{OUT}$ ) $R_L = 1\Omega$	$-dV/dt_{off}$	1.1	1.9	2.6	V/ $\mu\text{s}$

<sup>7)</sup> Thermal resistance  $R_{thCH}$  case to heatsink (about 0.5 ... 0.9 K/W with silicone paste) not included!

<sup>8)</sup> Device on 50mm\*50mm\*1.5mm epoxy PCB FR4 with 6cm<sup>2</sup> (one layer, 70 $\mu\text{m}$  thick) copper area for  $V_{bb}$  connection. PCB is vertical without blown air.

<sup>9)</sup> not subject to production test, specified by design

<sup>10)</sup>  $T_j$  is about 105 $^\circ\text{C}$  under these conditions.

<sup>11)</sup> See timing diagram on page 14.

Parameter and Conditions at $T_j = -40 \dots +150^\circ\text{C}$ , $V_{bb} = 24\text{ V}$ unless otherwise specified	Symbol	Values			Unit
		min	typ	max	

**Inverse Load Current Operation**

On-state resistance (Pins 1,2,6,7 to pin 4) $V_{bIN} = 12\text{ V}$ , $I_L = -20\text{ A}$ see diagram on page 10	$T_j = 25^\circ\text{C}$ : $T_j = 150^\circ\text{C}$ :	$R_{ON(inv)}$	--	7.2 14.6	9 17	$\text{m}\Omega$
Nominal inverse load current (Pins 1,2,6,7 to Tab) $V_{ON} = -0.5\text{ V}$ , $T_C = 85^\circ\text{C}$		$I_{L(inv)}$	50	60	--	A
Drain-source diode voltage ( $V_{out} > V_{bb}$ ) $I_L = -20\text{ A}$ , $I_{IN} = 0$ , $T_j = +150^\circ\text{C}$		$-V_{ON}$	--	0.6	0.7	mV

**Operating Parameters**

Operating voltage ( $V_{IN} = 0$ ) <sup>12)</sup>		$V_{bb(on)}$	5.0	--	58	V
Under voltage shutdown <sup>13)14)</sup>		$V_{bIN(u)}$	1.5	3.0	4.5	V
Under voltage start of charge pump see diagram page 15		$V_{bIN(ucp)}$	3.0	4.5	6.0	V
Over voltage protection <sup>15)</sup> $I_{bb} = 15\text{ mA}$	$T_j = -40^\circ\text{C}$ : $T_j = 25\dots+150^\circ\text{C}$ :	$V_{bIN(z)}$	68 70	-- 72	-- --	V
Standby current $I_{IN} = 0$ , $V_{bb} = 35\text{ V}$	$T_j = -40\dots+25^\circ\text{C}$ : $T_j = 150^\circ\text{C}$ :	$I_{bb(off)}$	-- --	15 25	25 50	$\mu\text{A}$

<sup>12)</sup> If the device is turned on before a  $V_{bb}$ -decrease, the operating voltage range is extended down to  $V_{bIN(u)}$ . For the voltage range 0..58 V the device provides embedded protection functions against overtemperature and short circuit.

<sup>13)</sup> not subject to production test, specified by design

<sup>14)</sup>  $V_{bIN} = V_{bb} - V_{IN}$  see diagram on page 15. When  $V_{bIN}$  increases from less than  $V_{bIN(u)}$  up to  $V_{bIN(ucp)} = 5\text{ V}$  (typ.) the charge pump is not active and  $V_{OUT} \approx V_{bb} - 3\text{ V}$ .

<sup>15)</sup> See also  $V_{ON(CL)}$  in circuit diagram on page 9.

Parameter and Conditions at $T_j = -40 \dots +150^\circ\text{C}$ , $V_{bb} = 24\text{ V}$ unless otherwise specified	Symbol	Values			Unit
		min	typ	max	
<b>Protection Functions<sup>16)</sup></b>					
Short circuit current limit (Tab to pins 1,2,6,7) $V_{ON} = 24\text{ V}$ , time until shutdown max. 300 $\mu\text{s}$ see page 8 and 13	$I_{L(SC)}$	--	90	180	A
	$I_{L(SC)}$	--	90	--	
	$I_{L(SC)}$	50	80	--	
Short circuit shutdown delay after input current positive slope, $V_{ON} > V_{ON(SC)}$ <sup>17)</sup> min. value valid only if input "off-signal" time exceeds 30 $\mu\text{s}$	$t_{d(SC)}$	80	--	350	$\mu\text{s}$
Output clamp (inductive load switch off) at $V_{OUT} = V_{bb} - V_{ON(CL)}$ (e.g. over voltage) $I_L = 40\text{ mA}$	$V_{ON(CL)}$	62	65	72	V
Short circuit shutdown detection voltage <sup>17)</sup> (pin 4 to pins 1,2,6,7)	$V_{ON(SC)}$	--	6	--	V
Thermal overload trip temperature	$T_{jt}$	150	--	--	$^\circ\text{C}$
Thermal hysteresis	$\Delta T_{jt}$	--	10	--	K

### Reverse Battery

Reverse battery voltage <sup>18)</sup>	$-V_{bb}$	--	--	42	V
On-state resistance (Pins 1,2,6,7 to pin 4) $V_{bb} = -12\text{ V}$ , $V_{IN} = 0$ , $I_L = -20\text{ A}$ , $R_{IS} = 1\text{ k}\Omega$	$R_{ON(rev)}$	--	8.8	10.5	$\text{m}\Omega$
			--	20	
Integrated resistor in $V_{bb}$ line	$R_{bb}$	90	120	135	$\Omega$
		105	125	150	

<sup>16)</sup> Integrated protection functions are designed to prevent IC destruction under fault conditions described in the data sheet. Fault conditions are considered as "outside" normal operating range. Protection functions are not designed for continuous repetitive operation.

<sup>17)</sup> not subject to production test, specified by design.

<sup>18)</sup> The reverse load current through the intrinsic drain-source diode has to be limited by the connected load (as it is done with all polarity symmetric loads). Note that under off-conditions ( $I_{IN} = I_{IS} = 0$ ) the power transistor is not activated. This results in raised power dissipation due to the higher voltage drop across the intrinsic drain-source diode. The temperature protection is not active during reverse current operation! To reduce the power dissipation at the integrated  $R_{bb}$  resistor an input resistor is recommended as described on page 9.

Parameter and Conditions at $T_j = -40 \dots +150^\circ\text{C}$ , $V_{bb} = 24\text{ V}$ unless otherwise specified	Symbol	Values			Unit
		min	typ	max	

**Diagnostic Characteristics**

Current sense ratio, static on-condition, $k_{\text{ILIS}} = I_L : I_{\text{S}}$ , $V_{\text{ON}} < 1.5\text{ V}^{19)}$ , $V_{\text{IS}} < V_{\text{OUT}} - 5\text{ v}$ , $V_{\text{bIN}} > 4.0\text{ V}$ see diagram on page 12	$I_L = 80\text{ A}, T_j = -40^\circ\text{C}$ :	$k_{\text{ILIS}}$	11 400	13 000	15 400	
	$T_j = 25^\circ\text{C}$ :		11 400	13 000	14 600	
	$T_j = 150^\circ\text{C}$ :		11 000	13 000	14 200	
	$I_L = 20\text{ A}, T_j = -40^\circ\text{C}$ :		11 000	13 000	16 000	
	$T_j = 25^\circ\text{C}$ :		11 000	13 000	15 000	
	$T_j = 150^\circ\text{C}$ :		11 000	13 000	14 500	
	$I_L = 10\text{ A}, T_j = -40^\circ\text{C}$ :		10 500	13 000	17 000	
	$T_j = 25^\circ\text{C}$ :		10 500	13 000	15 500	
	$T_j = 150^\circ\text{C}$ :		11 000	13 000	15 000	
	$I_L = 4\text{ A}, T_j = -40^\circ\text{C}$ :		9 000	13 000	22 000	
	$T_j = 25^\circ\text{C}$ :		10 000	13 000	18 500	
	$T_j = 150^\circ\text{C}$ :		10 800	13 000	16 000	
$I_{\text{IN}} = 0, I_{\text{S}} = 0$ (e.g. during deenergizing of inductive loads):		--	--	--		
Sense current saturation	$I_{\text{S,lim}}$	6.5	--	--	mA	
Current sense leakage current	$I_{\text{IN}} = 0$	$I_{\text{S(LL)}}$	--	--	0.5	$\mu\text{A}$
	$V_{\text{IN}} = 0, I_L < 0$ :	$I_{\text{S(LH)}}$	--	2	65	
Current sense over voltage protection $I_{\text{bb}} = 15\text{ mA}$	$T_j = -40^\circ\text{C}$ :	$V_{\text{bIS(Z)}}$	68	--	--	V
	$T_j = 25 \dots +150^\circ\text{C}$ :		70	72	--	
Current sense settling time <sup>20)</sup>		$t_{\text{S(IS)}}$	--	--	500	$\mu\text{s}$

**Input**

Input and operating current (see diagram page 13) IN grounded ( $V_{\text{IN}} = 0$ )	$I_{\text{IN(on)}}$	--	0.8	1.5	mA
Input current for turn-off <sup>21)</sup>	$I_{\text{IN(off)}}$	--	--	80	$\mu\text{A}$

<sup>19)</sup> If  $V_{\text{ON}}$  is higher, the sense current is no longer proportional to the load current due to sense current saturation, see  $I_{\text{S,lim}}$ .

<sup>20)</sup> not subject to production test, specified by design

<sup>21)</sup> We recommend the resistance between IN and GND to be less than  $0.5\text{ k}\Omega$  for turn-on and more than  $500\text{ k}\Omega$  for turn-off. Consider that when the device is switched off ( $I_{\text{IN}} = 0$ ) the voltage between IN and GND reaches almost  $V_{\text{bb}}$ .

Truth Table

	Input current level	Output level	Current Sense $I_{IS}$	Remark
Normal operation	L H	L H	0 nominal	$=I_L / k_{IIS}$ , up to $I_{IS}=I_{IS,lim}$
Very high load current	H	H	$I_{IS, lim}$	up to $V_{ON}=V_{ON(Fold\ back)}$ $I_{IS}$ no longer proportional to $I_L$
Current-limitation	H	H	0	$V_{ON} > V_{ON(Fold\ back)}$ if $V_{ON}>V_{ON(SC)}$ , shutdown will occur
Short circuit to GND	L H	L L	0 0	
Over-temperature	L H	L L	0 0	
Short circuit to $V_{bb}$	L H	H H	0 <nominal <sup>22)</sup>	
Open load	L H	Z <sup>23)</sup> H	0 0	
Negative output voltage clamp	L	L	0	
Inverse load current	L H	H H	0 0	

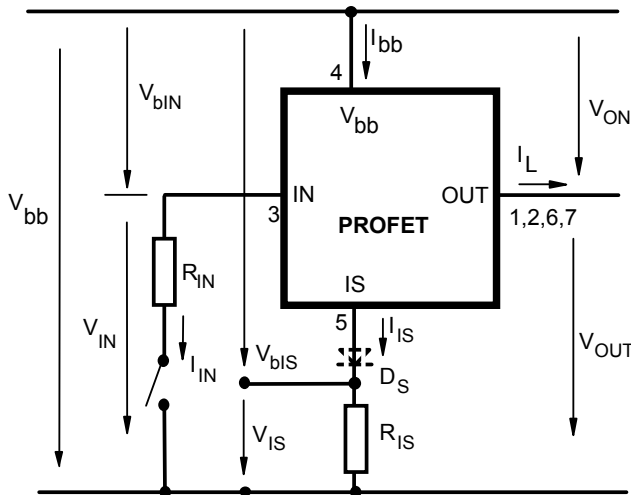
L = "Low" Level

H = "High" Level

Over temperature reset by cooling:  $T_j < T_{jt}$  (see diagram on page 15)

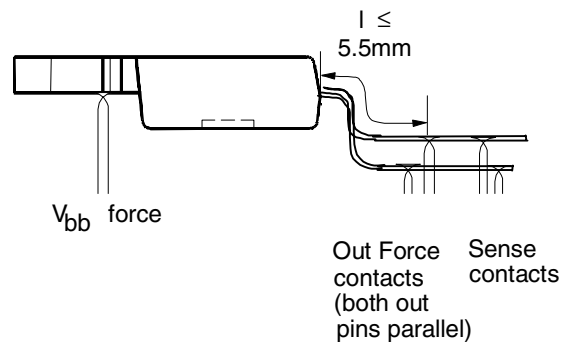
Short circuit to GND: Shutdown remains latched until next reset via input (see diagram on page 14)

Terms



Two or more devices can easily be connected in parallel to increase load current capability.

RON measurement layout



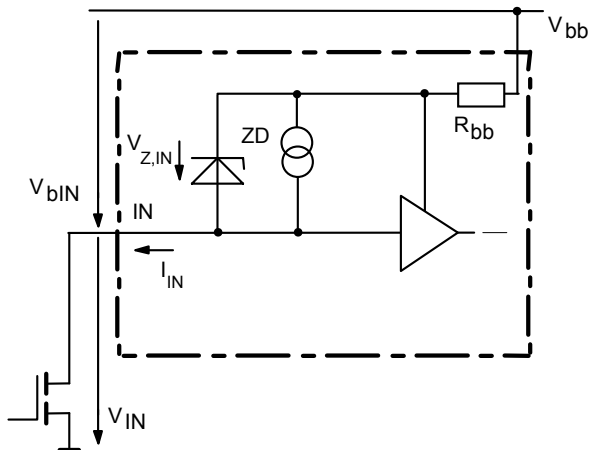
Typical RON for SMD version is about 0.2 mΩ less than straight leads due to  $l \approx 2\text{ mm}$

<sup>22)</sup> Low ohmic short to  $V_{bb}$  may reduce the output current  $I_L$  and can thus be detected via the sense current  $I_{IS}$ .

<sup>23)</sup> Power Transistor "OFF", potential defined by external impedance.



**Input circuit (ESD protection)**

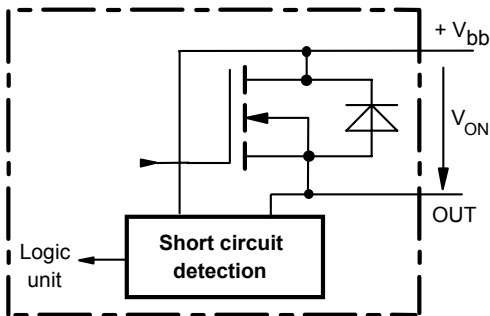


When the device is switched off ( $I_{IN} = 0$ ) the voltage between IN and GND reaches almost  $V_{bb}$ . Use a bipolar or MOS transistor with appropriate breakdown voltage as driver.

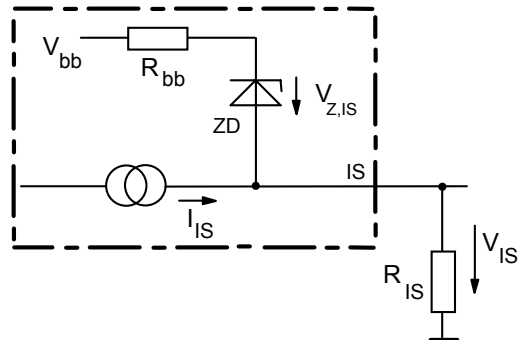
$V_{Z,IN} = 74\text{ V (typ.)}$

**Short circuit detection**

Fault Condition:  $V_{ON} > V_{ON(SC)}$  (6 V typ.) and  $t > t_{d(SC)}$  (80 ...300  $\mu\text{s}$ ).



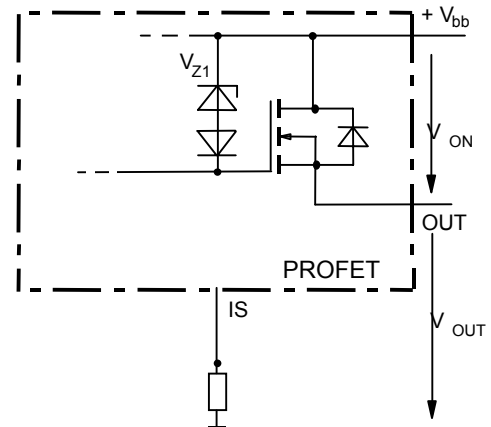
**Current sense status output**



$V_{Z,IS} = 74\text{ V (typ.)}$ ,  $R_{IS} = 1\text{ k}\Omega$  nominal (or  $1\text{ k}\Omega/n$ , if  $n$  devices are connected in parallel).  $I_S = I_L/k_{ILIS}$  can be driven only by the internal circuit as long as  $V_{out} - V_{IS} > 5\text{ V}$ . If you want measure load currents up to  $I_{L(M)}$ ,  $R_{IS}$  should be less than  $\frac{V_{bb} - 5\text{ V}}{I_{L(M)} / K_{ILIS}}$ .

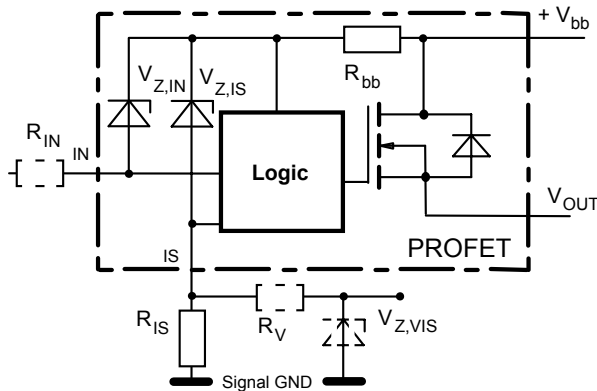
Note: For large values of  $R_{IS}$  the voltage  $V_{IS}$  can reach almost  $V_{bb}$ . See also over voltage protection. If you don't use the current sense output in your application, you can leave it open.

**Inductive and over voltage output clamp**



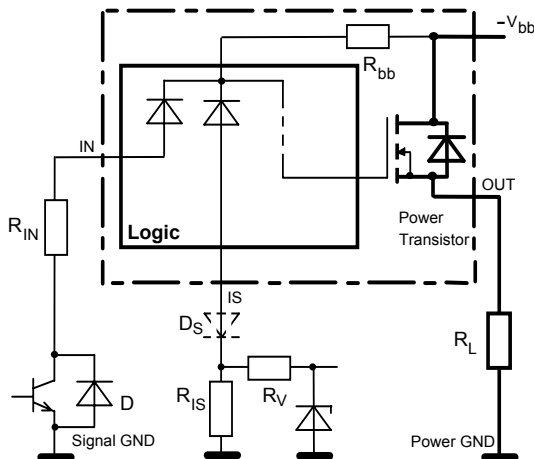
$V_{ON}$  is clamped to  $V_{ON(Cl)} = 62\text{ V typ}$

**Over voltage protection of logic part**



$R_{bb} = 120\Omega$  typ.,  $V_{Z,IN} = V_{Z,IS} = 74V$  typ.,  $R_{IS} = 1k\Omega$  nominal. Note that when over voltage exceeds 79V typ. a voltage above 5V can occur between IS and GND, if  $R_V, V_{Z,VIS}$  are not used.

**Reverse battery protection**



$R_V \geq 1k\Omega, R_{IS} = 1k\Omega$  nominal. Add  $R_{IN}$  for reverse battery protection in applications with  $V_{bb}$  above 16V<sup>18)</sup>;

recommended value:  $\frac{1}{R_{IN}} + \frac{1}{R_{IS}} + \frac{1}{R_V} = \frac{0.1A}{|V_{bb}| - 12V}$  if  $D_S$

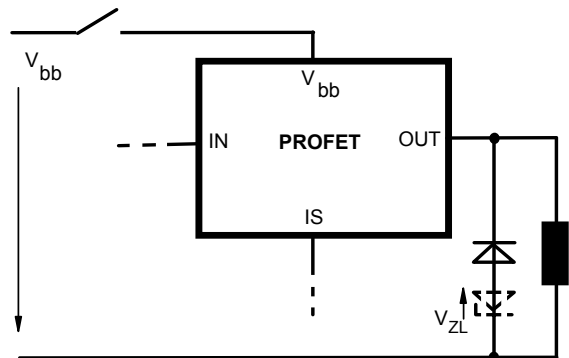
is not used (or  $\frac{1}{R_{IN}} = \frac{0.1A}{|V_{bb}| - 12V}$  if  $D_S$  is used).

To minimize power dissipation at reverse battery operation, the overall current into the IN and IS pin should be about 120mA. The current can be provided by using a small signal diode D in parallel to the input switch, by using a MOSFET input switch or by proper adjusting the current through  $R_{IS}$  and  $R_V$ .

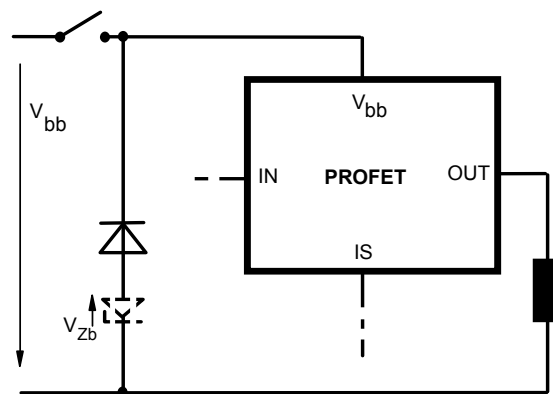
**V<sub>bb</sub> disconnect with energized inductive load**

Provide a current path with load current capability by using a diode, a Z-diode, or a varistor. ( $V_{ZL} < 70V$  or  $V_{Zb} < 42V$  if  $R_{IN}=0$ ). For higher clamp voltages currents at IN and IS have to be limited to 250 mA.

Version a:

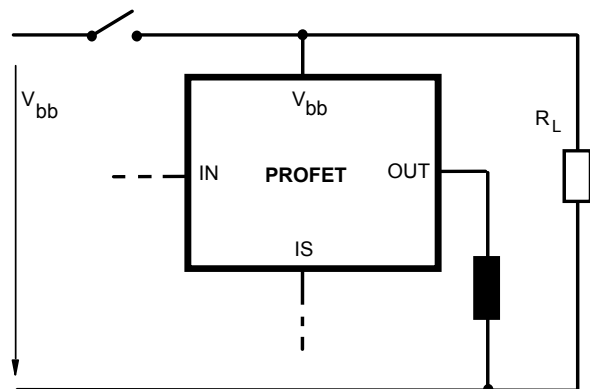


Version b:

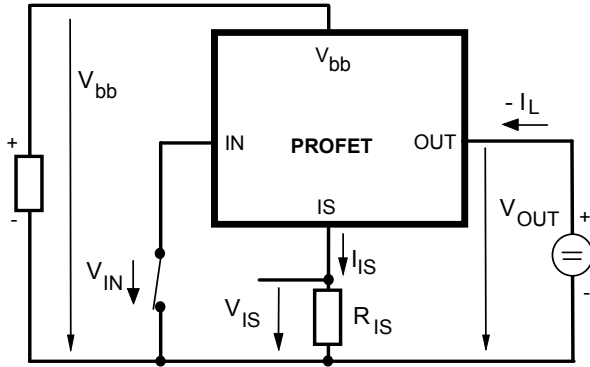


Note that there is no reverse battery protection when using a diode without additional Z-diode  $V_{ZL}, V_{Zb}$ .

Version c: Sometimes a necessary voltage clamp is given by non inductive loads  $R_L$  connected to the same switch and eliminates the need of clamping circuit:



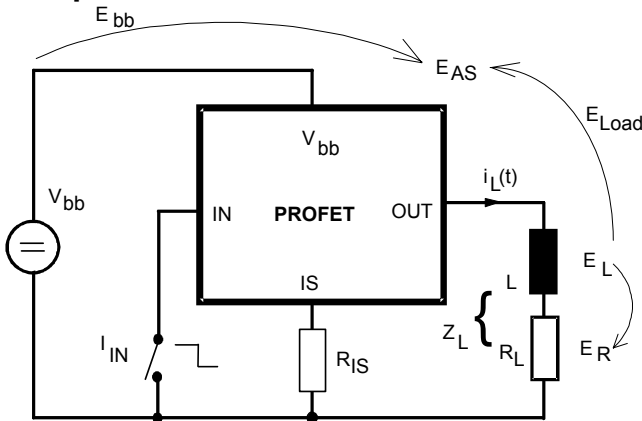
**Inverse load current operation**



The device is specified for inverse load current operation ( $V_{OUT} > V_{bb} > 0V$ ). The current sense feature is not available during this kind of operation ( $I_{IS} = 0$ ). With  $I_{IN} = 0$  (e.g. input open) only the intrinsic drain source diode is conducting resulting in considerably increased power dissipation. If the device is switched on ( $V_{IN} = 0$ ), this power dissipation is decreased to the much lower value  $R_{ON(INV)} \cdot I^2$  (specifications see page 4).

Note: Temperature protection during inverse load current operation is not possible!

**Inductive load switch-off energy dissipation**



Energy stored in load inductance:

$$E_L = 1/2 \cdot L \cdot I_L^2$$

While demagnetizing load inductance, the energy dissipated in PROFET is

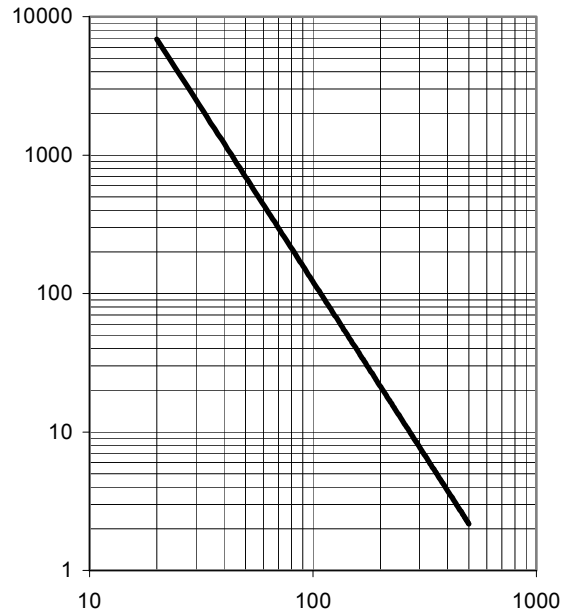
$$E_{AS} = E_{bb} + E_L - E_R = \int V_{ON(CL)} \cdot i_L(t) dt,$$

with an approximate solution for  $R_L > 0 \Omega$ :

$$E_{AS} = \frac{I_L \cdot L}{2 \cdot R_L} (V_{bb} + |V_{OUT(CL)}|) \ln \left( 1 + \frac{I_L \cdot R_L}{|V_{OUT(CL)}|} \right)$$

**Maximum allowable load inductance for a single switch off**

$$L = f(I_L); T_{j,start} = 150^\circ C, V_{bb} = 40 V, R_L = 0 \Omega$$

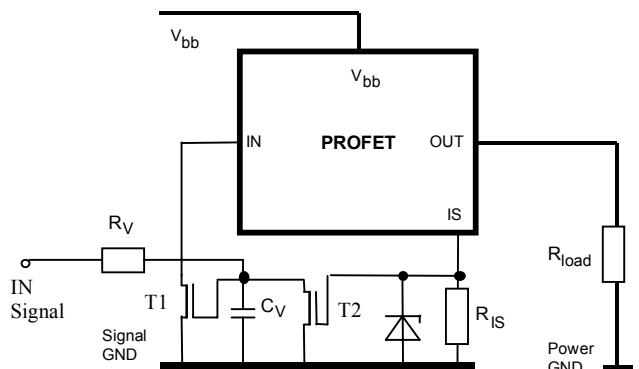


L [μH]

I [A]

**Externally adjustable current limit**

If the device is conducting, the sense current can be used to reduce the short circuit current and allow higher lead inductance (see diagram above). The device will be turned off, if the threshold voltage of T2 is reached by  $I_s \cdot R_{IS}$ . After a delay time defined by  $R_V \cdot C_V$  T1 will be reset. The device is turned on again, the short circuit current is defined by  $I_{L(SC)}$  and the device is shut down after  $t_{d(SC)}$  with latch function.



**Options Overview**

Type	BTS50085-1TMB
Over temperature protection with hysteresis $T_j > 150\text{ °C}$ , latch function <sup>24)</sup>	X
$T_j > 150\text{ °C}$ , with auto-restart on cooling	X
Short circuit to GND protection switches off when $V_{ON} > 6\text{ V typ.}$ (when first turned on after approx. 180 $\mu\text{s}$ )	X
Over voltage shutdown	-
Output negative voltage transient limit to $V_{bb} - V_{ON(CL)}$ to $V_{OUT} = -15\text{ V typ}$	X X <sup>25)</sup>

<sup>24)</sup> Latch except when  $V_{bb} - V_{OUT} < V_{ON(SC)}$  after shutdown. In most cases  $V_{OUT} = 0\text{ V}$  after shutdown ( $V_{OUT} \neq 0\text{ V}$  only if forced externally). So the device remains latched unless  $V_{bb} < V_{ON(SC)}$  (see page 5). No latch between turn on and  $t_{d(SC)}$ .

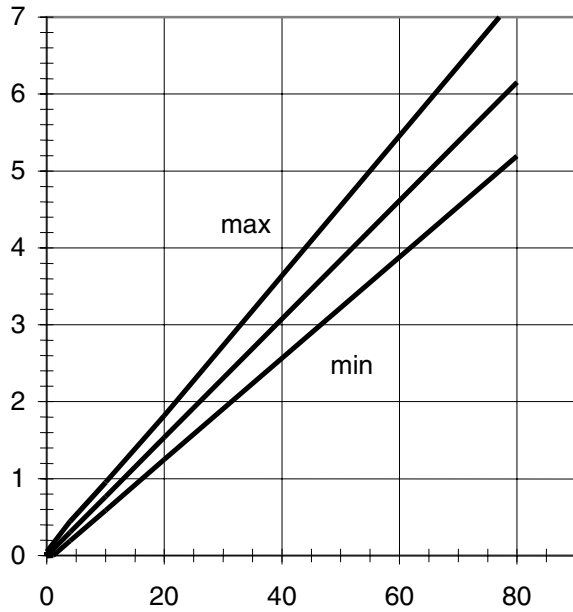
<sup>25)</sup> Can be "switched off" by using a diode  $D_S$  (see page 8) or leaving open the current sense output.

## Characteristics

### Current sense versus load current:

$$I_S = f(I_L), T_J = -40 \dots +150 \text{ } ^\circ\text{C}$$

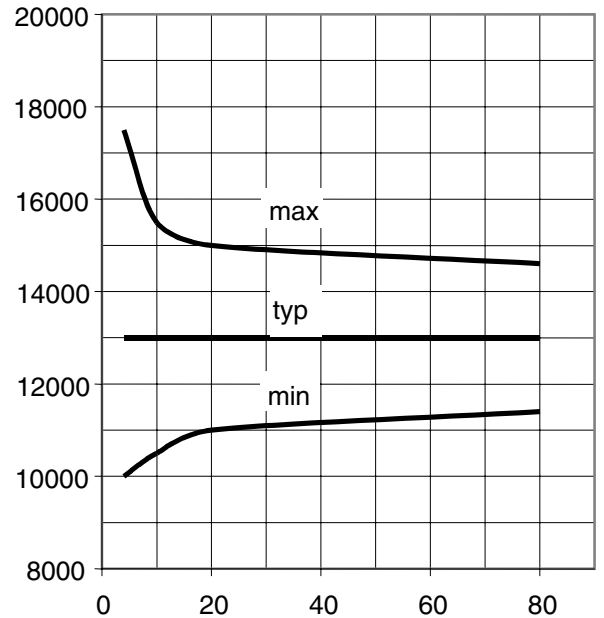
$I_S$  [mA]



$I_L$  [A]  $k_{ILIS}$

### Current sense ratio:

$$K_{ILIS} = f(I_L), T_J = 25^\circ\text{C}$$

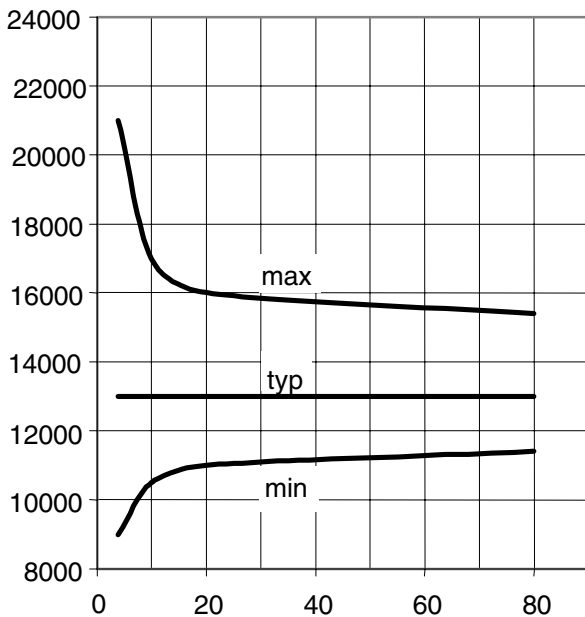


$I_L$  [A]

### Current sense ratio:

$$K_{ILIS} = f(I_L), T_J = -40^\circ\text{C}$$

$k_{ILIS}$

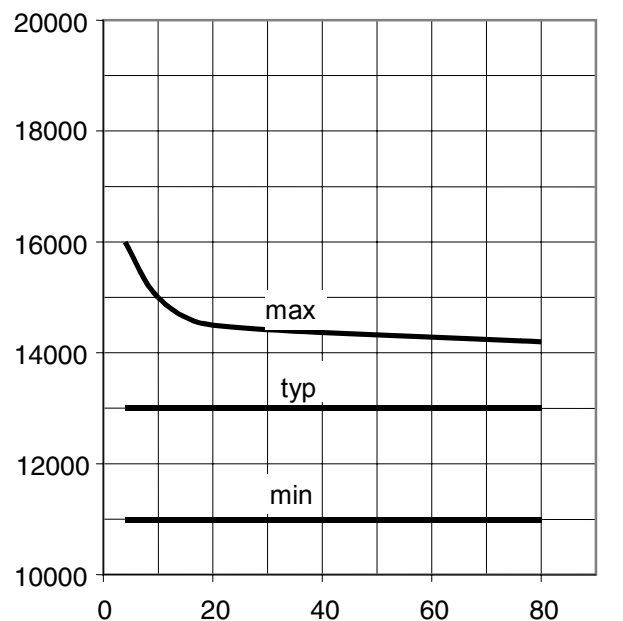


$I_L$  [A]

### Current sense ratio:

$$K_{ILIS} = f(I_L), T_J = 150^\circ\text{C}$$

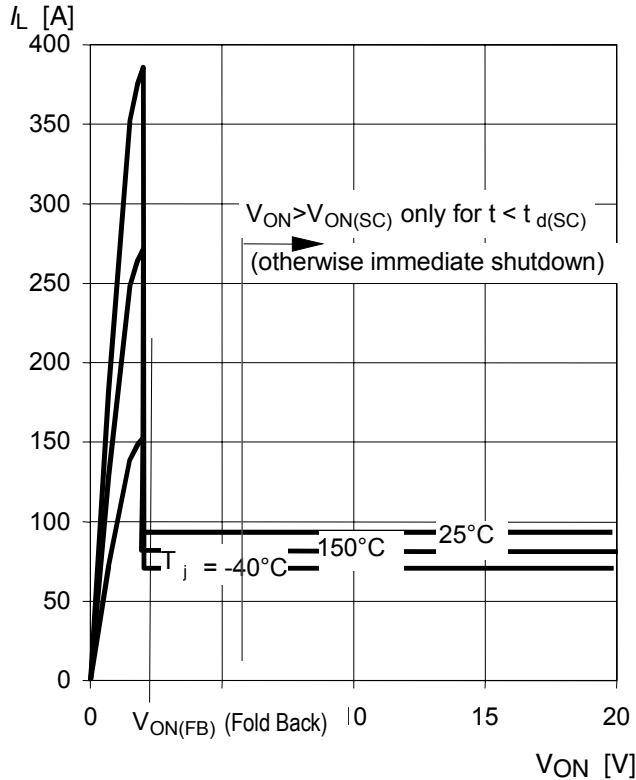
$k_{ILIS}$



$I_L$  [A]

**Typ. current limitation characteristic**

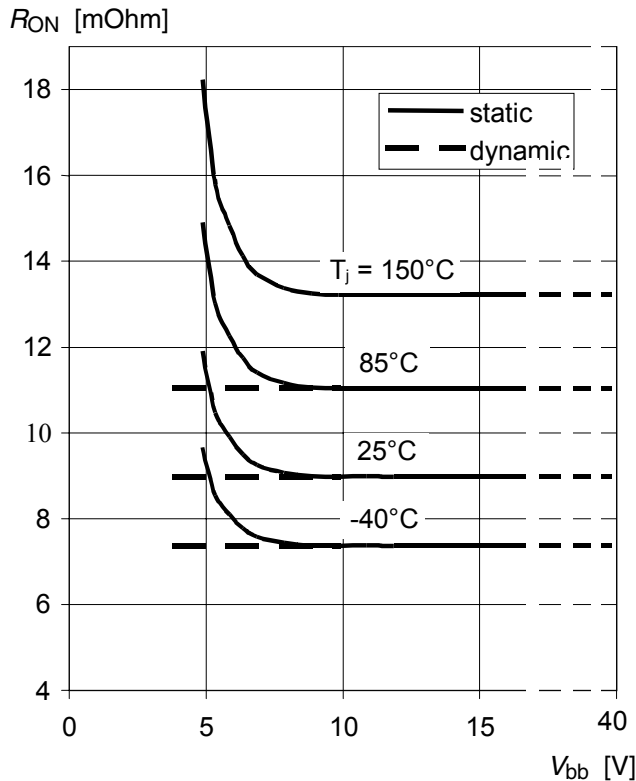
$I_L = f(V_{ON}, T_j)$



In case of  $V_{ON} > V_{ON(SC)}$  (typ. 6 V) the device will be switched off by internal short circuit detection.

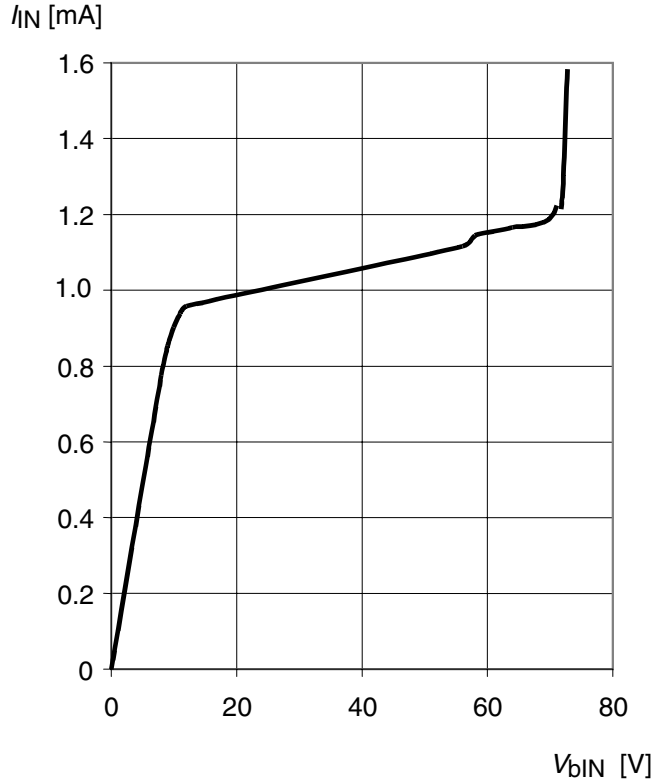
**Typ. on-state resistance**

$R_{ON} = f(V_{bb}, T_j); I_L = 20 \text{ A}; V_{IN} = 0$



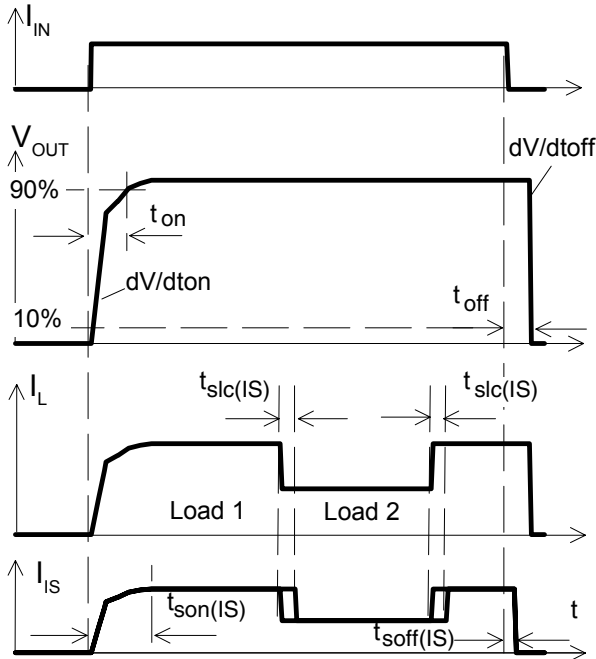
**Typ. input current**

$I_{IN} = f(V_{bIN}), V_{bIN} = V_{bb} - V_{IN}$



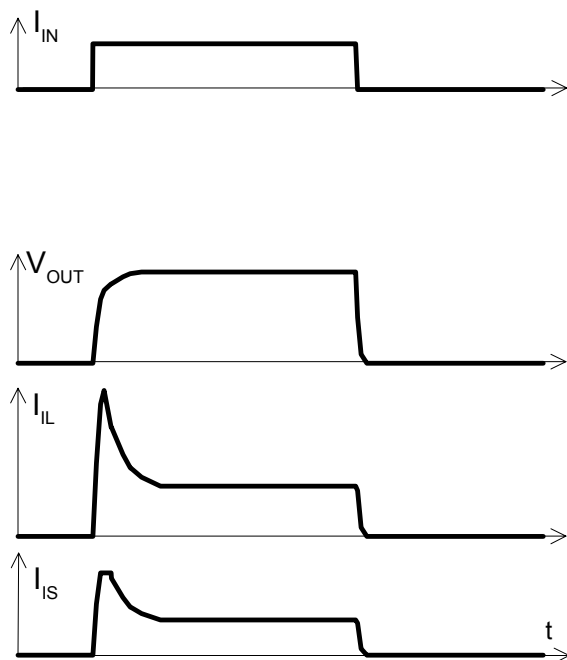
## Timing diagrams

**Figure 1a:** Switching a resistive load, change of load current in on-condition:



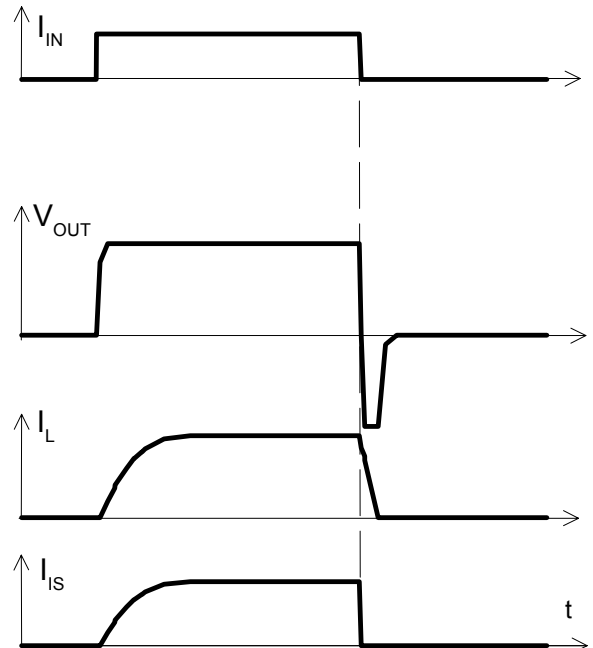
The sense signal is not valid during a settling time after turn-on/off and after change of load current.

**Figure 2b:** Switching motors and lamps:

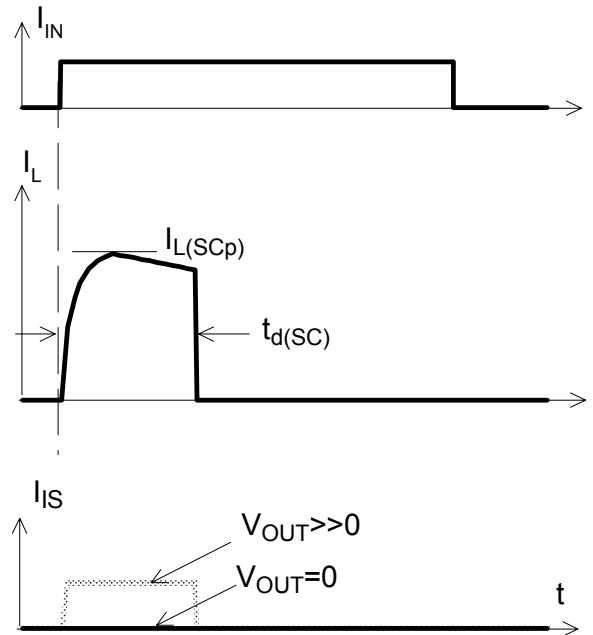


Sense current saturation can occur at very high inrush currents (see  $I_{IS,lim}$  on page 6).

**Figure 2c:** Switching an inductive load:

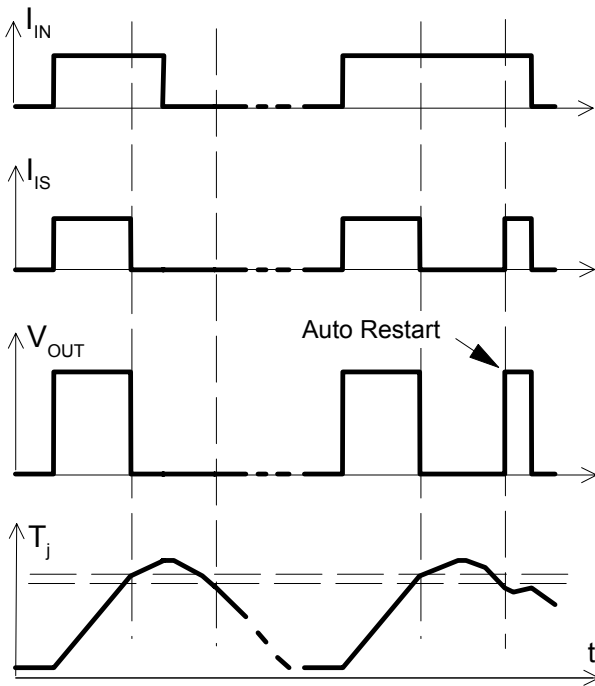


**Figure 3d:** Short circuit: shut down by short circuit detection, reset by  $I_{IN} = 0$ .

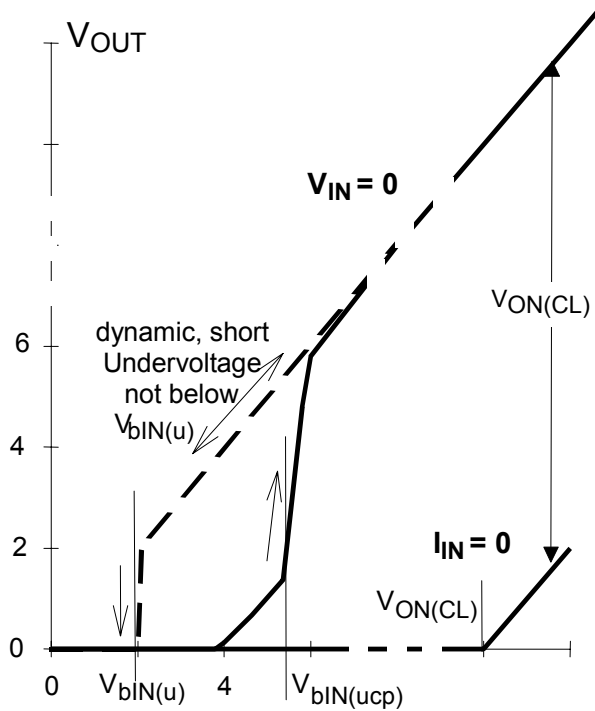


Shut down remains latched until next reset via input.

**Figure 4e:** Overtemperature Reset if  $T_j < T_{jt}$



**Figure 6f:** Undervoltage restart of charge pump, overvoltage clamp







## Revision History

<b>Version</b>	<b>Date</b>	<b>Changes</b>
Rev. 1.0	2008-01-24	Initial version of data sheet. Green (RoHS compliant) variant of BTS660P

**Edition 2008-Jan-24**

**Published by  
Infineon Technologies AG  
81726 Munich, Germany**

**© Infineon Technologies AG 2008.  
All Rights Reserved.**

#### **Legal Disclaimer**

The information given in this document shall in no event be regarded as a guarantee of conditions or characteristics ("Beschaffenhheitsgarantie"). With respect to any examples or hints given herein, any typical values stated herein and/or any information regarding the application of the device, Infineon Technologies hereby disclaims any and all warranties and liabilities of any kind, including without limitation warranties of non-infringement of intellectual property rights of any third party.

#### **Information**

For further information on technology, delivery terms and conditions and prices please contact your nearest Infineon Technologies Office ([www.infineon.com](http://www.infineon.com)).

#### **Warnings**

Due to technical requirements components may contain dangerous substances. For information on the types in question please contact your nearest Infineon Technologies Office.

Infineon Technologies Components may only be used in life-support devices or systems with the express written approval of Infineon Technologies, if a failure of such components can reasonably be expected to cause the failure of that life-support device or system, or to affect the safety or effectiveness of that device or system. Life support devices or systems are intended to be implanted in the human body, or to support and/or maintain and sustain and/or protect human life. If they fail, it is reasonable to assume that the health of the user or other persons may be endangered.