



Chipsmall Limited consists of a professional team with an average of over 10 year of expertise in the distribution of electronic components. Based in Hongkong, we have already established firm and mutual-benefit business relationships with customers from,Europe,America and south Asia,supplying obsolete and hard-to-find components to meet their specific needs.

With the principle of “Quality Parts,Customers Priority,Honest Operation,and Considerate Service”,our business mainly focus on the distribution of electronic components. Line cards we deal with include Microchip,ALPS,ROHM,Xilinx,Pulse,ON,Everlight and Freescale. Main products comprise IC,Modules,Potentiometer,IC Socket,Relay,Connector.Our parts cover such applications as commercial,industrial, and automotives areas.

We are looking forward to setting up business relationship with you and hope to provide you with the best service and solution. Let us make a better world for our industry!



## Contact us

Tel: +86-755-8981 8866 Fax: +86-755-8427 6832

Email & Skype: info@chipsmall.com Web: www.chipsmall.com

Address: A1208, Overseas Decoration Building, #122 Zhenhua RD., Futian, Shenzhen, China



# Smart High-Side Power Switch

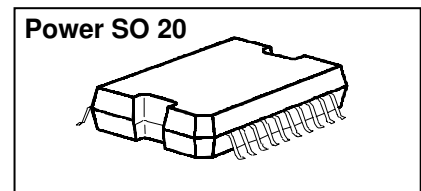
## Four Channels: 4 x 90mΩ

### Status Feedback

#### Product Summary

Operating Voltage	$V_{bb}$	5.5...40V	
	Active channels	one	four parallel
On-state Resistance	$R_{ON}$	90mΩ	22.5mΩ
Nominal load current	$I_{L(NOM)}$	4.7A	19.0A
Current limitation	$I_{L(SCr)}$	12A	12A

#### Package



#### General Description

- N channel vertical power MOSFET with charge pump, ground referenced CMOS compatible input and diagnostic feedback, monolithically integrated in Smart SIPMOS® technology.
- Providing embedded protective functions

#### Applications

- $\mu$ C compatible high-side power switch with diagnostic feedback for 12V and 24V grounded loads
- All types of resistive, inductive and capacitive loads
- Most suitable for loads with high inrush currents, so as lamps
- Replaces electromechanical relays, fuses and discrete circuits

#### Basic Functions

- Very low standby current
- CMOS compatible input
- Improved electromagnetic compatibility (EMC)
- Fast demagnetization of inductive loads
- Stable behaviour at undervoltage
- Wide operating voltage range
- Logic ground independent from load ground

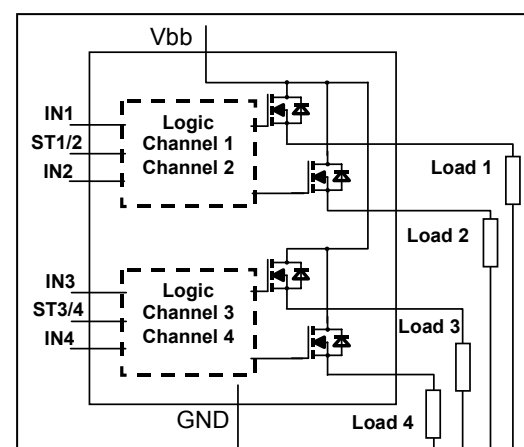
#### Protection Functions

- Short circuit protection
- Overload protection
- Current limitation
- Thermal shutdown
- Overvoltage protection (including load dump) with external resistor
- Reverse battery protection with external resistor
- Loss of ground and loss of  $V_{bb}$  protection
- Electrostatic discharge protection (ESD)

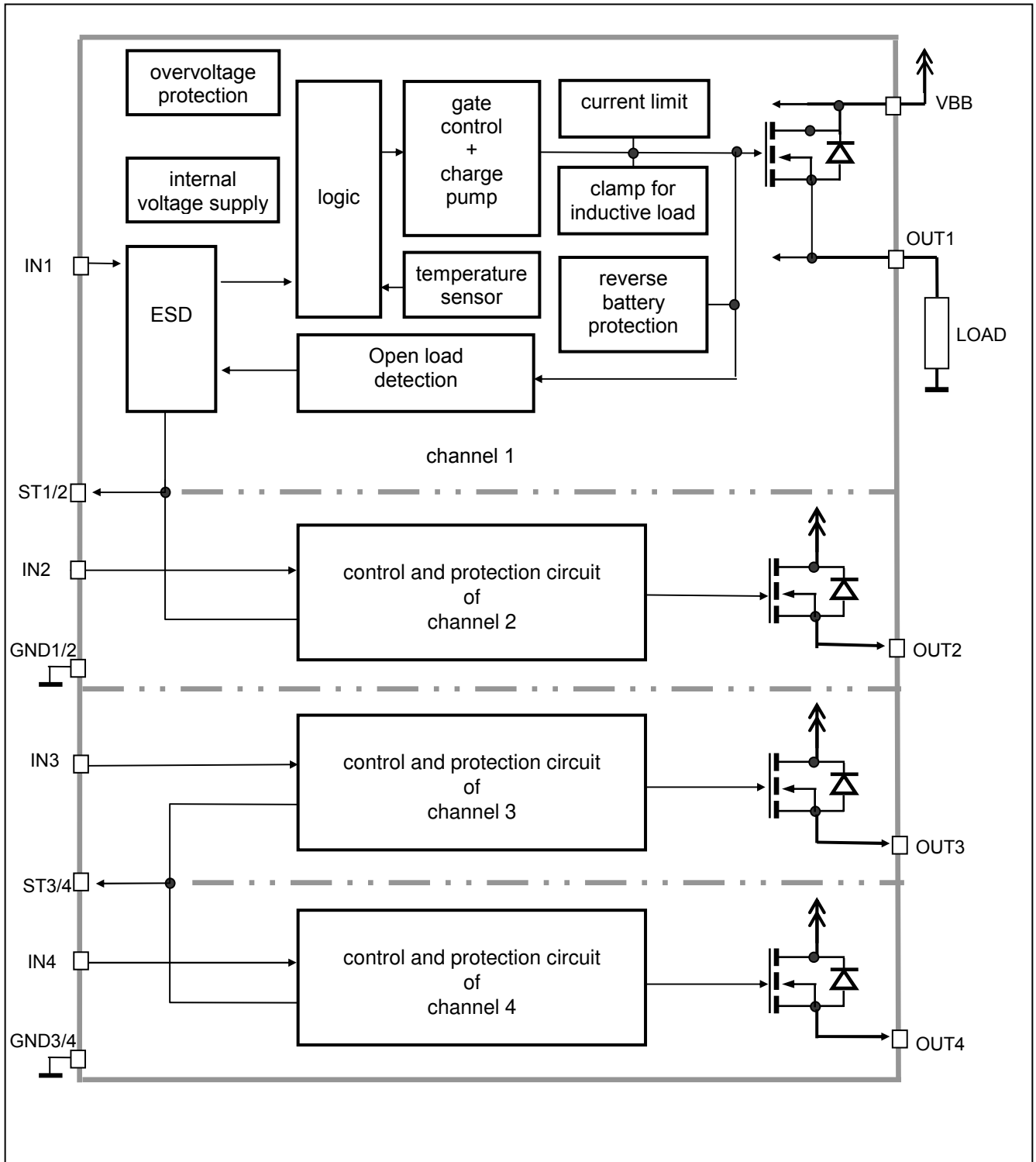
#### Diagnostic Function

- Diagnostic feedback with open drain output
- Open load detection in OFF-state
- Feedback of thermal shutdown in ON-state

#### Block Diagram

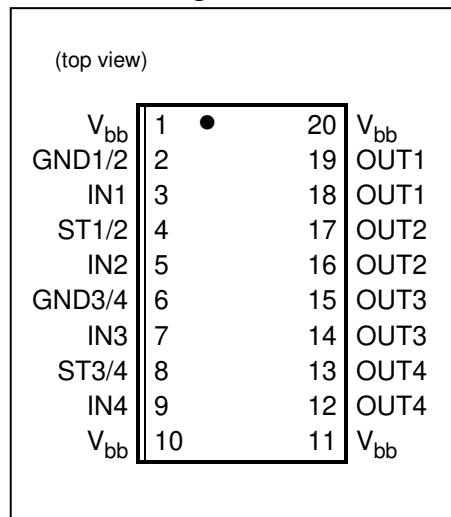


Functional diagram



**Pin Definitions and Functions**

Pin	Symbol	Function
1,10, 11,20	V <sub>bb</sub>	<b>Positive power supply voltage.</b> Design the wiring for the simultaneous max. short circuit currents from channel 1 to 2 and also for low thermal resistance
3	IN1	<b>Input 1,2, 3,4</b> activates channel 1,2,3,4 in case of logic high signal
5	IN2	
7	IN3	
9	IN4	
18,19	OUT1	<b>Output 1,2,3,4</b> protected high-side power output of channel 1,2,3,4. Design the wiring for the max. short circuit current
16,17	OUT2	
14,15	OUT3	
12,13	OUT4	
4	ST1/2	<b>Diagnostic feedback 1/2,3/4</b> of channel 1,2,3,4 open drain, low on failure
8	ST3/4	
2	GND1/2	<b>Ground</b> of chip 1 (channel 1,2)
6	GND3/4	<b>Ground</b> of chip 2 (channel 3,4)

**Pin configuration**


**Maximum Ratings** at  $T_j = 25^\circ\text{C}$  unless otherwise specified

Parameter	Symbol	Values	Unit
Supply voltage (overvoltage protection see page 6)	$V_{bb}$	43	V
Supply voltage for full short circuit protection $T_{j,start} = -40 \dots +150^\circ\text{C}$	$V_{bb}$	36	V
Load current (Short-circuit current, see page 6)	$I_L$	self-limited	A
Load dump protection <sup>1)</sup> $V_{LoadDump} = V_A + V_S$ , $V_A = 13.5\text{ V}$ $R_l^{2)} = 2\ \Omega$ , $t_d = 400\text{ ms}$ ; IN = low or high, each channel loaded with $R_L = 13.5\ \Omega$ ,	$V_{Load\ dump}^{3)}$	60	V
Operating temperature range	$T_j$	-40 ... +150	$^\circ\text{C}$
Storage temperature range	$T_{stg}$	-55 ... +150	
Power dissipation (DC) <sup>4)</sup> (all channels active)	$T_a = 25^\circ\text{C}$ : $T_a = 85^\circ\text{C}$ :	$P_{tot}$	3.6 1.9 W
Maximal switchable inductance, single pulse $V_{bb} = 12\text{ V}$ , $T_{j,start} = 150^\circ\text{C}^{4)}$ , see diagrams on page 10 $I_L = 4.7\text{ A}$ , $E_{AS} = 120\text{ mJ}$ , $0\ \Omega$ one channel: $I_L = 9.5\text{ A}$ , $E_{AS} = 230\text{ mJ}$ , $0\ \Omega$ two parallel channels: $I_L = 19.0\text{ A}$ , $E_{AS} = 450\text{ mJ}$ , $0\ \Omega$ four parallel channels:	$Z_L$	7.9 3.7 1.8	mH
Electrostatic discharge capability (ESD) (Human Body Model) IN: ST: out to all other pins shorted: acc. MIL-STD883D, method 3015.7 and ESD assn. std. S5.1-1993 $R=1.5\text{ k}\Omega$ ; $C=100\text{ pF}$	$V_{ESD}$	1.0 4.0 8.0	kV
Input voltage (DC) see internal circuit diagram page 9	$V_{IN}$	-10 ... +16	V
Current through input pin (DC)	$I_{IN}$	$\pm 0.3$	mA
Pulsed current through input pin <sup>5)</sup>	$I_{INp}$	$\pm 5.0$	
Current through status pin (DC)	$I_{ST}$	$\pm 5.0$	

1) Supply voltages higher than  $V_{bb(AZ)}$  require an external current limit for the GND and status pins (a  $150\ \Omega$  resistor for the GND connection is recommended).

2)  $R_l$  = internal resistance of the load dump test pulse generator

3)  $V_{Load\ dump}$  is setup without the DUT connected to the generator per ISO 7637-1 and DIN 40839

4) Device on  $50\text{ mm} \times 50\text{ mm} \times 1.5\text{ mm}$  epoxy PCB FR4 with  $6\text{ cm}^2$  (one layer,  $70\ \mu\text{m}$  thick) copper area for  $V_{bb}$  connection. PCB is vertical without blown air. See page 14

5) only for testing



## Thermal Characteristics

Parameter and Conditions	Symbol	Values			Unit
		min	typ	max	
Thermal resistance junction - soldering point <sup>6)7)</sup> each channel:	$R_{thjs}$	--	--	5	K/W
junction – ambient <sup>6)</sup>	$R_{thja}$	--	42	--	
@ 6 cm <sup>2</sup> cooling area      one channel active:		--	34	--	
all channels active:		--	34	--	

## Electrical Characteristics

Parameter and Conditions, each of the four channels at $T_j = -40\dots+150^\circ\text{C}$ , $V_{bb} = 12\text{ V}$ unless otherwise specified	Symbol	Values			Unit
		min	typ	max	

### Load Switching Capabilities and Characteristics

On-state resistance ( $V_{bb}$ to OUT); $I_L = 2\text{ A}$ each channel, $T_j = 25^\circ\text{C}$ : $T_j = 150^\circ\text{C}$ : two parallel channels, $T_j = 25^\circ\text{C}$ : four parallel channels, $T_j = 25^\circ\text{C}$ : see diagram, page 11	$R_{ON}$	--	70 140	90 180	m $\Omega$
Nominal load current      one channel active: two parallel channels active: four parallel channels active: Device on PCB <sup>6)</sup> , $T_a = 85^\circ\text{C}$ , $T_j \leq 150^\circ\text{C}$	$I_{L(NOM)}$	3.7 7.4 14.8	4.7 9.5 19.0	-- -- --	A
Output current while GND disconnected or pulled up <sup>8)</sup> ; $V_{bb} = 32\text{ V}$ , $V_{IN} = 0$ , see diagram page 9	$I_{L(GNDhigh)}$	--	--	2	mA
Turn-on time <sup>9)</sup> IN  to 90% $V_{OUT}$ :	$t_{on}$	--	100	250	$\mu\text{s}$
Turn-off time      IN  to 10% $V_{OUT}$ : $R_L = 12\ \Omega$	$t_{off}$	--	100	270	
Slew rate on <sup>9)</sup> 10 to 30% $V_{OUT}$ , $R_L = 12\ \Omega$ :	$dV/dt_{on}$	0.2	--	1.0	V/ $\mu\text{s}$
Slew rate off <sup>9)</sup> 70 to 40% $V_{OUT}$ , $R_L = 12\ \Omega$ :	$-dV/dt_{off}$	0.2	--	1.1	V/ $\mu\text{s}$

6) Device on 50mm\*50mm\*1.5mm epoxy PCB FR4 with 6cm<sup>2</sup> (one layer, 70 $\mu\text{m}$  thick) copper area for  $V_{bb}$  connection. PCB is vertical without blown air. See page 14

7) Soldering point: upper side of solder edge of device pin 15. See page 14

8) not subject to production test, specified by design

9) See timing diagram on page 12.



Parameter and Conditions, each of the four channels at $T_j = -40\dots+150^\circ\text{C}$ , $V_{bb} = 12\text{ V}$ unless otherwise specified	Symbol	Values			Unit
		min	typ	max	

### Operating Parameters

Operating voltage	$V_{bb(\text{on})}$	5.5	--	40	V	
Undervoltage switch off <sup>10)</sup>	$T_j = -40^\circ\text{C}\dots 25^\circ\text{C}$ : $V_{bb(\text{u so})}$	--	--	4.5	V	
		$T_j = 125^\circ\text{C}$ :	--	--	4.5 <sup>11)</sup>	
Overvoltage protection <sup>12)</sup> $I_{bb} = 40\text{ mA}$	$V_{bb(\text{AZ})}$	41	47	52	V	
Standby current <sup>13)</sup> $V_{\text{IN}} = 0$ ; see diagram page 11	$T_j = -40^\circ\text{C}\dots 25^\circ\text{C}$ : $I_{bb(\text{off})}$	--	9	20	$\mu\text{A}$	
		$T_j = 150^\circ\text{C}$ :	--	--	30	
		$T_j = 125^\circ\text{C}$ :	--	--	20 <sup>11)</sup>	
Off-State output current (included in $I_{bb(\text{off})}$ ) $V_{\text{IN}} = 0$ ; each channel	$I_{L(\text{off})}$	--	1	5	$\mu\text{A}$	
Operating current <sup>14)</sup> , $V_{\text{IN}} = 5\text{V}$ , $I_{\text{GND}} = I_{\text{GND}1} + I_{\text{GND}2}$ ,	one channel on: all channels on:	$I_{\text{GND}}$	--	0.6	1.2	mA
		--	--	2.4	4.8	

### Protection Functions<sup>15)</sup>

Current limit, $V_{\text{out}} = 0\text{V}$ , (see timing diagrams, page 12)	$T_j = -40^\circ\text{C}$ : $T_j = 25^\circ\text{C}$ : $T_j = +150^\circ\text{C}$ :	$I_{L(\text{lim})}$	--	--	23	A
		--	--	15	--	
		9	--	--	--	
Repetitive short circuit current limit, $T_j = T_{jt}$ each channel two, three or four parallel channels (see timing diagrams, page 12)	$I_{L(\text{SCR})}$	--	12	--	A	
		--	12	--		
Initial short circuit shutdown time $V_{\text{out}} = 0\text{V}$ (see timing diagrams on page 12)	$T_{j,\text{start}} = 25^\circ\text{C}$ :	$t_{\text{off}(\text{SC})}$	--	2	--	ms
Output clamp (inductive load switch off) <sup>16)</sup> at $V_{\text{ON}(\text{CL})} = V_{bb} - V_{\text{OUT}}$ , $I_L = 40\text{ mA}$	$V_{\text{ON}(\text{CL})}$	41	47	52	V	
Thermal overload trip temperature	$T_{jt}$	150	--	--	$^\circ\text{C}$	
Thermal hysteresis	$\Delta T_{jt}$	--	10	--	K	

<sup>10)</sup> is the voltage, where the device doesn't change its switching condition for 15ms after the supply voltage falling below  $V_{bb(\text{on})}$

<sup>11)</sup> not subject to production test, specified by design

<sup>12)</sup> Supply voltages higher than  $V_{bb(\text{AZ})}$  require an external current limit for the GND and status pins (a 150 $\Omega$  resistor for the GND connection is recommended). See also  $V_{\text{ON}(\text{CL})}$  in table of protection functions and circuit diagram on page 9.

<sup>13)</sup> Measured with load; for the whole device; all channels off

<sup>14)</sup> Add  $I_{\text{ST}}$ , if  $I_{\text{ST}} > 0$

<sup>15)</sup> Integrated protection functions are designed to prevent IC destruction under fault conditions described in the data sheet. Fault conditions are considered as "outside" normal operating range. Protection functions are not designed for continuous repetitive operation.

<sup>16)</sup> If channels are connected in parallel, output clamp is usually accomplished by the channel with the lowest  $V_{\text{ON}(\text{CL})}$

Parameter and Conditions, each of the four channels at $T_j = -40\dots+150^\circ\text{C}$ , $V_{bb} = 12\text{ V}$ unless otherwise specified	Symbol	Values			Unit
		min	typ	max	



### Reverse Battery

Reverse battery voltage <sup>17)</sup>	$-V_{bb}$	--	--	32	V
Drain-source diode voltage ( $V_{out} > V_{bb}$ ) $I_L = -2.0\text{ A}$ , $T_j = +150^\circ\text{C}$	$-V_{ON}$	--	600	--	mV

### Diagnostic Characteristics

Open load detection voltage	$V_{OUT(OL)}$	1.7	2.8	4.0	V
-----------------------------	---------------	-----	-----	-----	---

### Input and Status Feedback<sup>18)</sup>

Input resistance (see circuit page 9)	$R_I$	2.5	4.0	6.0	k $\Omega$
Input turn-on threshold voltage 	$V_{IN(T+)}$	--	--	2.5	V
Input turn-off threshold voltage 	$V_{IN(T-)}$	1.0	--	--	V
Input threshold hysteresis	$\Delta V_{IN(T)}$	--	0.2	--	V
Status change after positive input slope <sup>19)</sup> with open load	$t_{d(STon)}$	--	10	20	$\mu\text{s}$
Status change after positive input slope <sup>19)</sup> with overload	$t_{d(STon)}$	30	--	--	$\mu\text{s}$
Status change after negative input slope with open load	$t_{d(SToff)}$	--	--	500	$\mu\text{s}$
Status change after negative input slope <sup>19)</sup> with overtemperature	$t_{d(SToff)}$	--	--	20	$\mu\text{s}$
Off state input current $V_{IN} = 0.4\text{ V}$ :	$I_{IN(off)}$	5	--	20	$\mu\text{A}$
On state input current $V_{IN} = 5\text{ V}$ :	$I_{IN(on)}$	10	35	60	$\mu\text{A}$
Status output (open drain)					
Zener limit voltage $I_{ST} = +1.6\text{ mA}$ :	$V_{ST(high)}$	5.4	--	--	V
ST low voltage $I_{ST} = +1.6\text{ mA}$ :	$V_{ST(low)}$	--	--	0.6	

<sup>17)</sup> Requires a 150  $\Omega$  resistor in GND connection. The reverse load current through the intrinsic drain-source diode has to be limited by the connected load. Power dissipation is higher compared to normal operating conditions due to the voltage drop across the drain-source diode. The temperature protection is not active during reverse current operation! Input and Status currents have to be limited (see max. ratings page 4 and circuit page 9).

<sup>18)</sup> If ground resistors  $R_{GND}$  are used, add the voltage drop across these resistors.

<sup>19)</sup> not subject to production test, specified by design



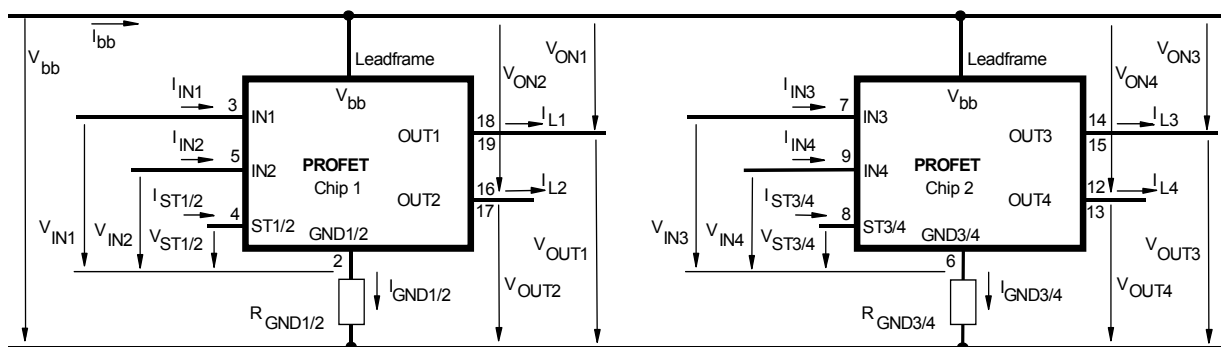
### Truth Table

Channel 1 and 2	Chip 1	IN1	IN2	OUT1	OUT2	ST1/2
Channel 3 and 4 (equivalent to channel 1 and 2)	Chip 2	IN3	IN4	OUT3	OUT4	ST3/4
Normal operation		L	L	L	L	H
		L	H	L	H	H
		H	L	H	L	H
		H	H	H	H	H
Open load	Channel 1 (3)	L	X	Z	X	L <sup>20)</sup>
		H	X	H	X	H
	Channel 2 (4)	X	L	X	Z	L <sup>20)</sup>
		X	H	X	H	H
Overtemperature	both channel	L	L	L	L	H
		X	H	L	L	L
		H	X	L	L	L
		X	X	L	L	L
	Channel 1 (3)	L	X	L	X	H
		H	X	L	X	L
	Channel 2 (4)	X	L	X	L	H
		X	H	X	L	L

L = "Low" Level      X = don't care      Z = high impedance, potential depends on external circuit  
H = "High" Level      Status signal valid after the time delay shown in the timing diagrams

Parallel switching of channel 1 and 2 (also channel 3 and 4) is easily possible by connecting the inputs and outputs in parallel (see truth table). If switching channel 1 to 4 in parallel, the status outputs ST1/2 and ST3/4 have to be configured as a 'Wired OR' function with a single pull-up resistor.

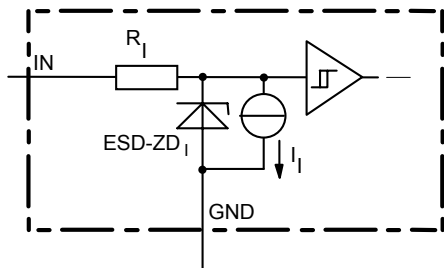
### Terms



Leadframe (V<sub>bb</sub>) is connected to pin 1,10,11,20  
External R<sub>GND</sub> optional; two resistors R<sub>GND1</sub>, R<sub>GND2</sub> = 150 Ω or a single resistor R<sub>GND</sub> = 75 Ω for reverse battery protection up to the max. operating voltage.

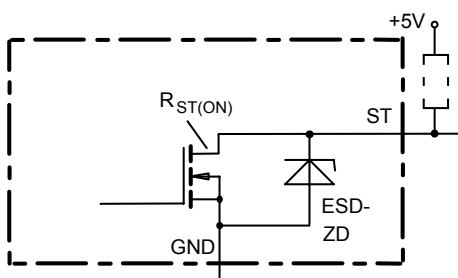
<sup>20)</sup> L, if potential at the Output exceeds the OpenLoad detection voltage

**Input circuit (ESD protection), IN1 to IN4**



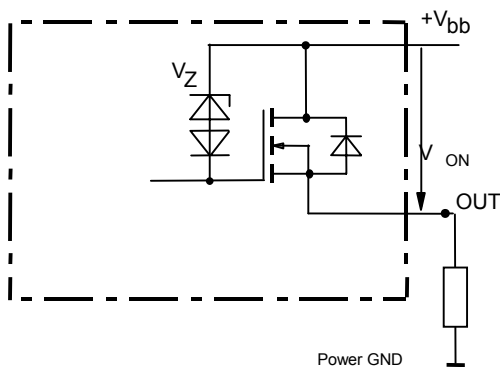
The use of ESD zener diodes as voltage clamp at DC conditions is not recommended.

**Status output, ST1/2 or ST3/4**



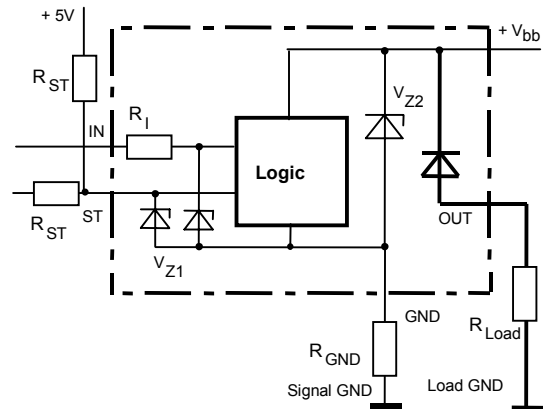
ESD-Zener diode: 6.1 V typ., max 0.3 mA;  $R_{ST(ON)} < 375 \Omega$  at 1.6 mA. The use of ESD zener diodes as voltage clamp at DC conditions is not recommended.

**Inductive and overvoltage output clamp, OUT1...4**



$V_{ON}$  clamped to  $V_{ON(CL)} = 47 \text{ V typ.}$

**Overvolt. and reverse batt. protection**



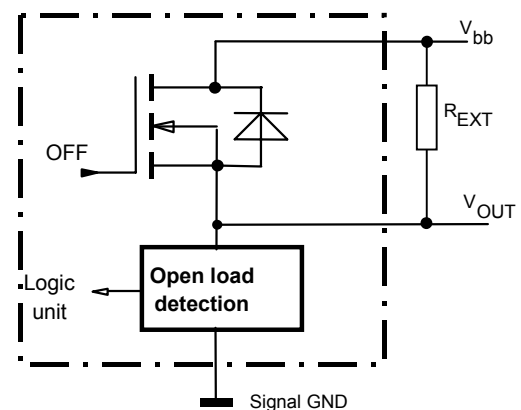
$V_{Z1} = 6.1 \text{ V typ.}$ ,  $V_{Z2} = 47 \text{ V typ.}$ ,  $R_{GND} = 150 \Omega$ ,  $R_{ST} = 15 \text{ k}\Omega$ ,  $R_1 = 4.0 \text{ k}\Omega \text{ typ.}$

In case of reverse battery the load current has to be limited by the load. Temperature protection is not active

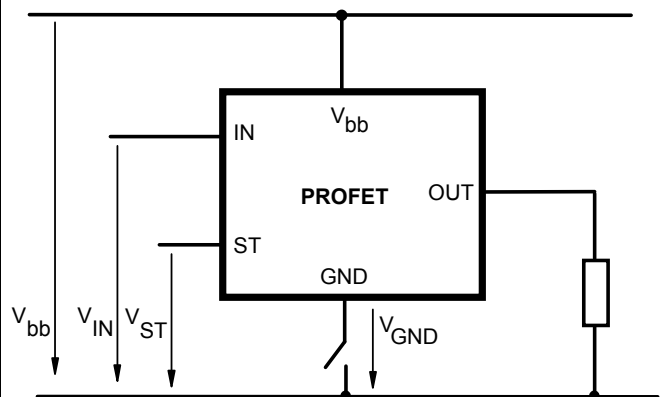
**Open-load detection, OUT1...4**

OFF-state diagnostic condition:

Open Load, if  $V_{OUT} > 3 \text{ V typ.}$ ; IN low

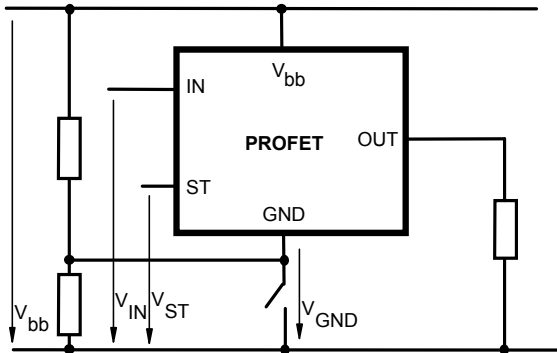


**GND disconnect**



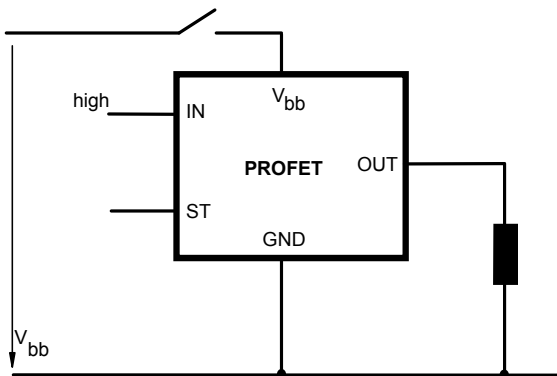
Any kind of load. In case of IN=high is  $V_{OUT} \approx V_{IN} - V_{IN(T+)}$ . Due to  $V_{GND} > 0$ , no  $V_{ST} = \text{low}$  signal available.

**GND disconnect with GND pull up**



Any kind of load. If  $V_{GND} > V_{IN} - V_{IN(T+)}$  device stays off  
 Due to  $V_{GND} > 0$ , no  $V_{ST}$  = low signal available.

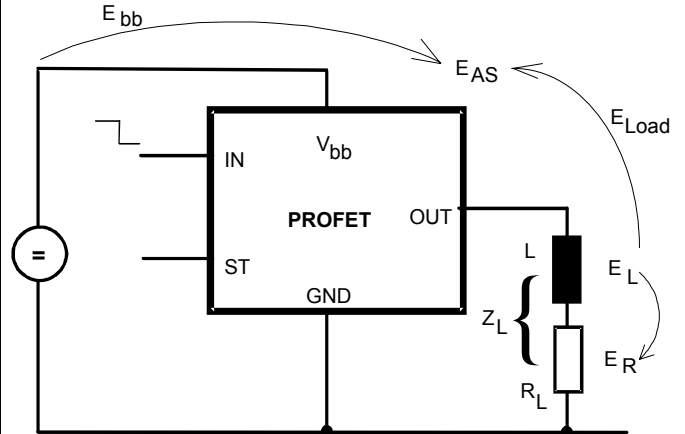
**Vbb disconnect with energized inductive load**



For inductive load currents up to the limits defined by  $Z_L$  (max. ratings and diagram on page 10) each switch is protected against loss of  $V_{bb}$ .

Consider at your PCB layout that in the case of  $V_{bb}$  disconnection with energized inductive load all the load current flows through the GND connection.

**Inductive load switch-off energy dissipation**



Energy stored in load inductance:

$$E_L = 1/2 \cdot L \cdot I_L^2$$

While demagnetizing load inductance, the energy dissipated in PROFET is

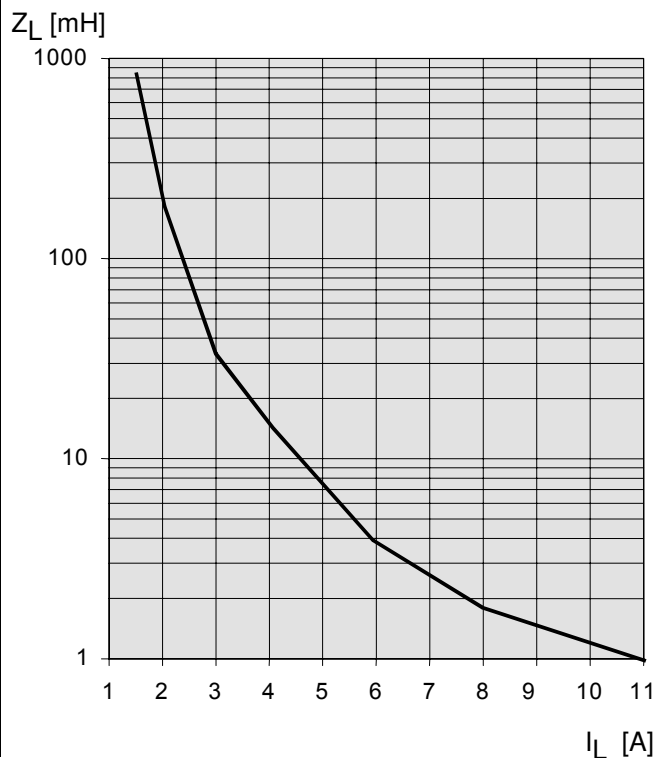
$$E_{AS} = E_{bb} + E_L - E_R = \int V_{ON(CL)} \cdot i_L(t) dt,$$

with an approximate solution for  $R_L > 0 \Omega$ :

$$E_{AS} = \frac{I_L \cdot L}{2 \cdot R_L} (V_{bb} + |V_{OUT(CL)}|) \ln \left( 1 + \frac{I_L \cdot R_L}{|V_{OUT(CL)}|} \right)$$

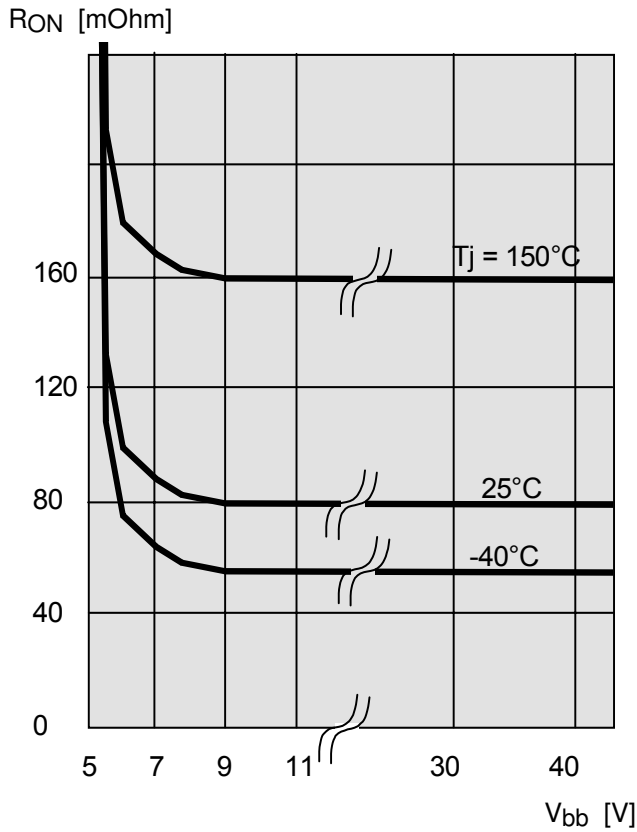
**Maximum allowable load inductance for a single switch off (one channel)<sup>4)</sup>**

$$L = f(I_L); T_{j,start} = 150^\circ C, V_{bb} = 12 V, R_L = 0 \Omega$$



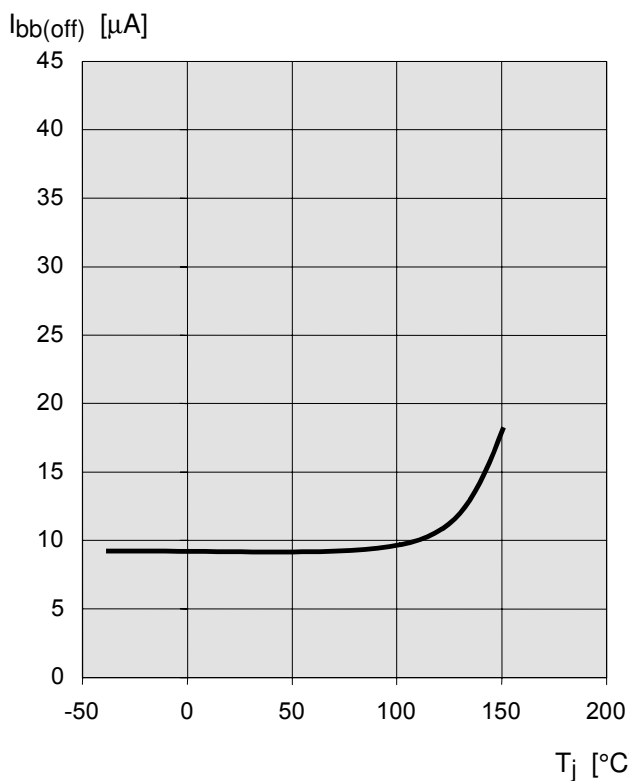
**Typ. on-state resistance**

$R_{ON} = f(V_{bb}, T_j)$ ;  $I_L = 2\text{ A}$ ,  $I_N = \text{high}$



**Typ. standby current**

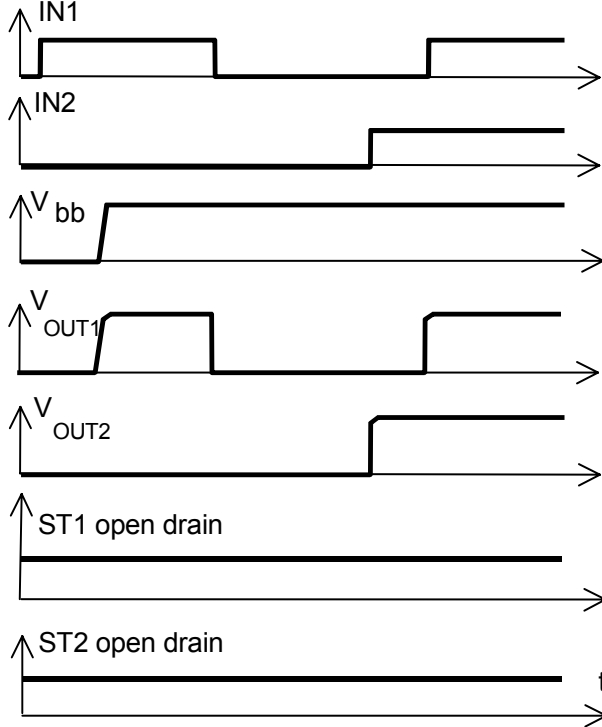
$I_{bb(off)} = f(T_j)$ ;  $V_{bb} = 9 \dots 34\text{ V}$ ,  $I_{N1,2,3,4} = \text{low}$



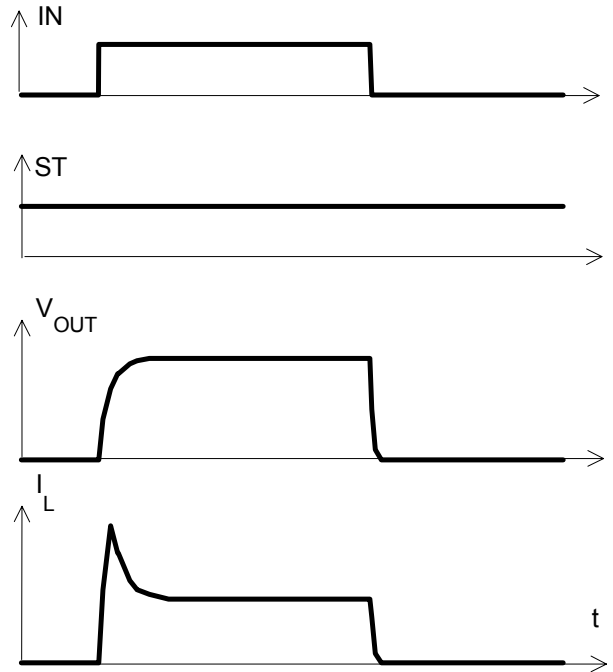
## Timing diagrams

All channels are symmetric and consequently the diagrams are valid for channel 1 to channel 4

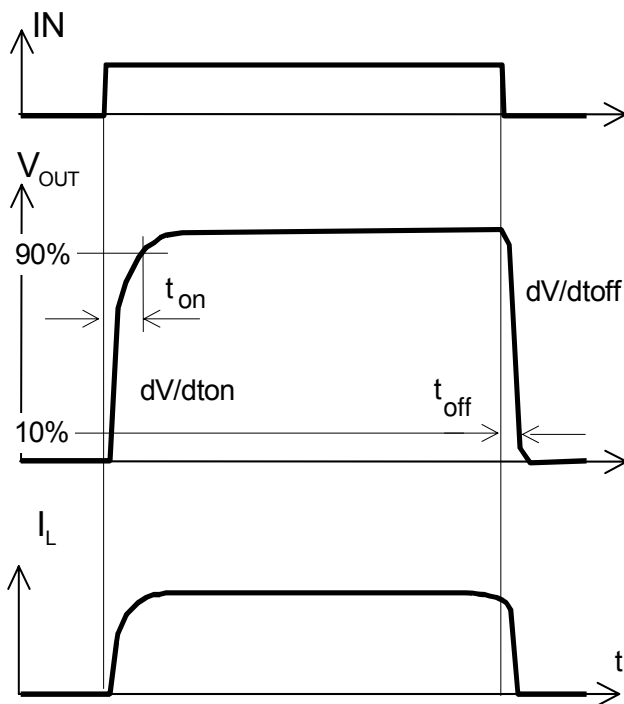
**Figure 1a:**  $V_{bb}$  turn on:



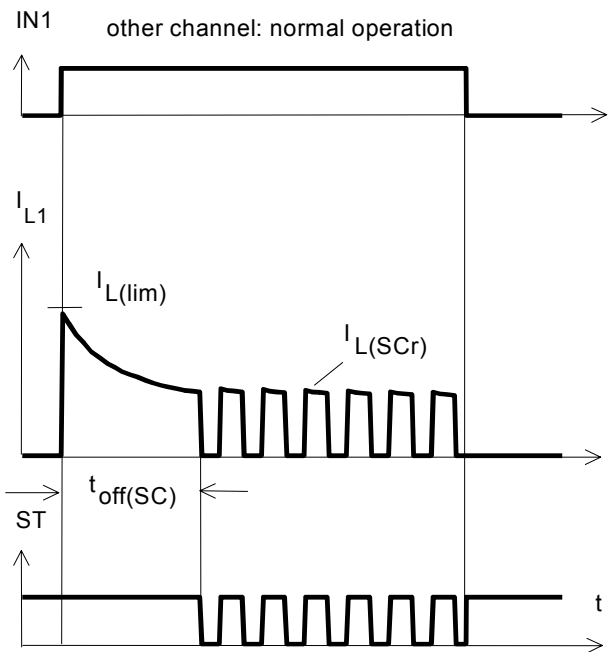
**Figure 2b:** Switching a lamp:



**Figure 2a:** Switching a resistive load, turn-on/off time and slew rate definition:

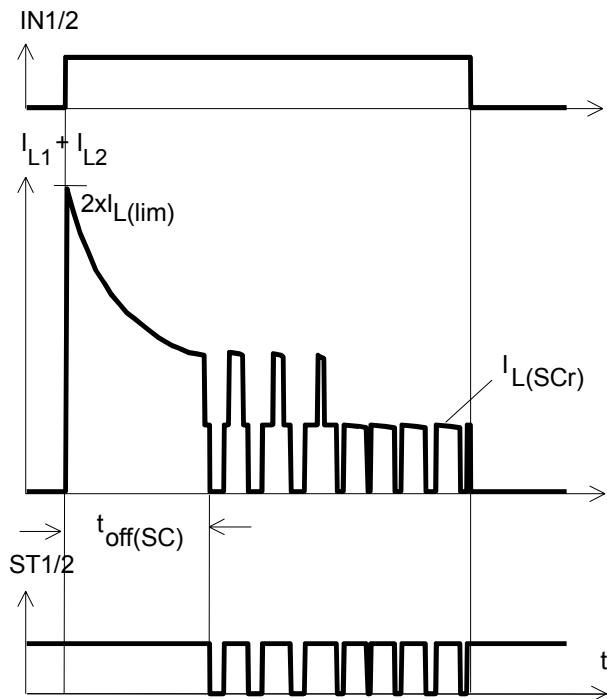


**Figure 3a:** Turn on into short circuit: shut down by overtemperature, restart by cooling



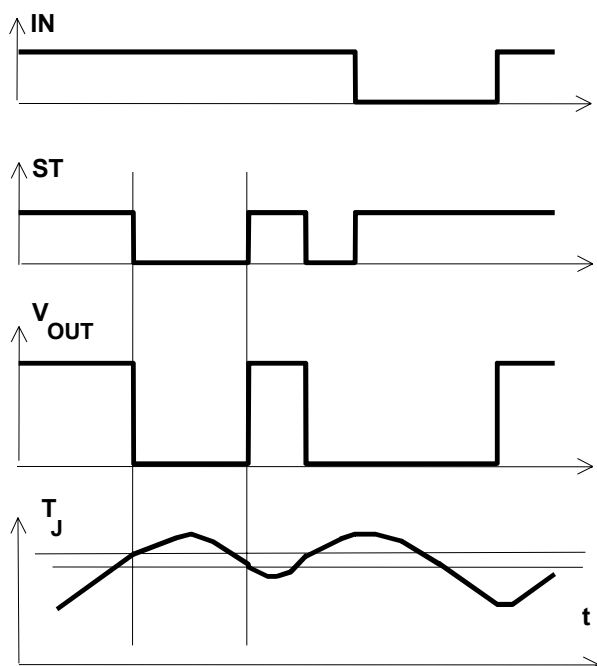
Heating up of the chip may require several milliseconds, depending on external conditions

**Figure 3b:** Turn on into short circuit: shut down by overtemperature, restart by cooling (two parallel switched channels 1 and 2)

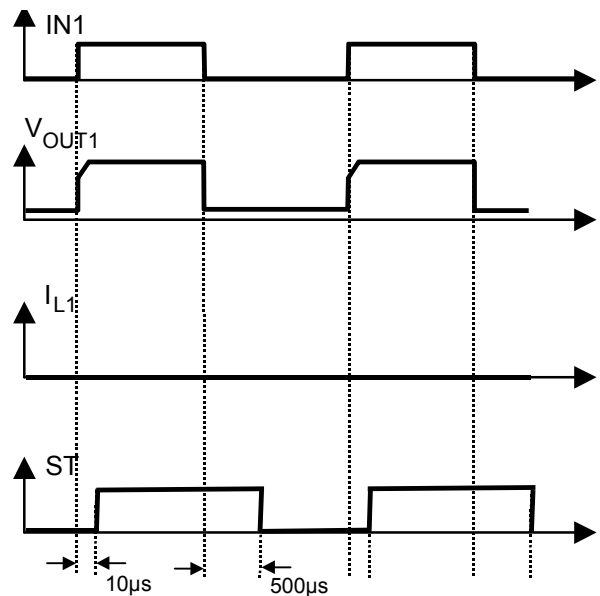


ST1 and ST2 have to be configured as a 'Wired OR' function ST1/2 with a single pull-up resistor.

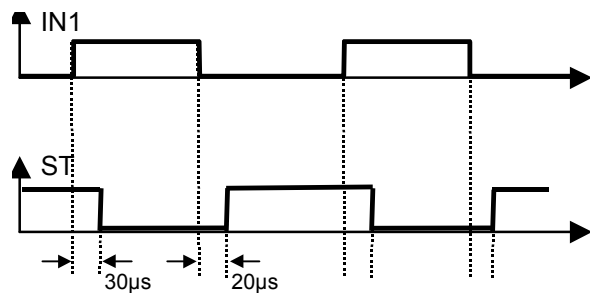
**Figure 4a:** Overtemperature: Reset if  $T_j < T_{jt}$



**Figure 5a:** Open load: detection in OFF-state, turn on/off to open load  
Open load of channel 1; other channels normal operation



**Figure 6a:** Status change after, turn on/off to overtemperature  
Overtemperature of channel 1; other channels normal operation

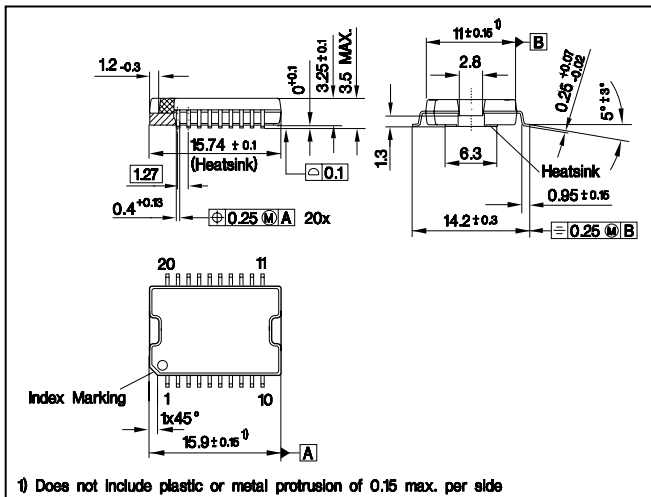


## Package and Ordering Code

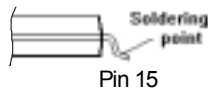
Standard: P-DSO-20-12 ( Power SO 20 )

Sales Code	BTS 824R
Ordering Code	Q67060-S7027

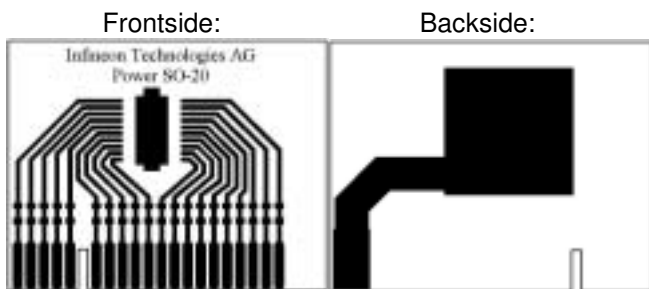
All dimensions in millimetres



Definition of soldering point with temperature  $T_S$ : upper side of solder edge of device pin 15.



Printed circuit board (FR4, 1.5mm thick, one layer 70µm, 6cm<sup>2</sup> active heatsink area) as a reference for max. power dissipation  $P_{tot}$ , nominal load current  $I_{L(NOM)}$  and thermal resistance  $R_{thja}$



Published by  
**Infineon Technologies AG,**  
**St.-Martin-Strasse 53,**  
**D-81669 München**  
 © Infineon Technologies AG 2001  
 All Rights Reserved.

### Attention please!

The information herein is given to describe certain components and shall not be considered as a guarantee of characteristics.

Terms of delivery and rights to technical change reserved.

We hereby disclaim any and all warranties, including but not limited to warranties of non-infringement, regarding circuits, descriptions and charts stated herein.

Infineon Technologies is an approved CECC manufacturer.

### Information

For further information on technology, delivery terms and conditions and prices please contact your nearest Infineon Technologies Office in Germany or our Infineon Technologies Representatives worldwide (see address list).

### Warnings

Due to technical requirements components may contain dangerous substances. For information on the types in question please contact your nearest Infineon Technologies Office.

Infineon Technologies Components may only be used in life-support devices or systems with the express written approval of Infineon Technologies, if a failure of such components can reasonably be expected to cause the failure of that life-support device or system, or to affect the safety or effectiveness of that device or system. Life support devices or systems are intended to be implanted in the human body, or to support and/or maintain and sustain and/or protect human life. If they fail, it is reasonable to assume that the health of the user or other persons may be endangered.