



Chipsmall Limited consists of a professional team with an average of over 10 year of expertise in the distribution of electronic components. Based in Hongkong, we have already established firm and mutual-benefit business relationships with customers from,Europe,America and south Asia,supplying obsolete and hard-to-find components to meet their specific needs.

With the principle of "Quality Parts,Customers Priority,Honest Operation,and Considerate Service",our business mainly focus on the distribution of electronic components. Line cards we deal with include Microchip,ALPS,ROHM,Xilinx,Pulse,ON,Everlight and Freescale. Main products comprise IC,Modules,Potentiometer,IC Socket,Relay,Connector.Our parts cover such applications as commercial,industrial, and automotives areas.

We are looking forward to setting up business relationship with you and hope to provide you with the best service and solution. Let us make a better world for our industry!



## Contact us

Tel: +86-755-8981 8866 Fax: +86-755-8427 6832

Email & Skype: info@chipsmall.com Web: www.chipsmall.com

Address: A1208, Overseas Decoration Building, #122 Zhenhua RD., Futian, Shenzhen, China



# PROFET™ + 24V

## BTT6010-1EKB

Smart High-Side Power Switch  
Single Channel, 10mΩ

### Data Sheet

PROFET™+ 24V  
Rev. 1.0, 2015-10-01

Automotive Power

## Table of Contents

|          |  |           |
|----------|--|-----------|
| <b>1</b> | <b>Overview</b> .....  | <b>4</b>  |
| <b>2</b> | <b>Block Diagram</b> .....   | <b>6</b>  |
| <b>3</b> | <b>Pin Configuration</b> .....   | <b>7</b>  |
| 3.1      | Pin Assignment .....   | 7         |
| 3.2      | Pin Definitions and Functions .....  | 7         |
| 3.3      | Voltage and Current Definition .....                                       | 8         |
| <b>4</b> | <b>General Product Characteristics</b> .....                               | <b>9</b>  |
| 4.1      | Absolute Maximum Ratings .....   | 9         |
| 4.2      | Functional Range .....   | 11        |
| 4.3      | Thermal Resistance .....   | 12        |
| 4.3.1    | PCB set up .....   | 12        |
| 4.3.2    | Thermal Impedance .....  | 13        |
| <b>5</b> | <b>Power Stage</b> .....   | <b>14</b> |
| 5.1      | Output ON-state Resistance .....   | 14        |
| 5.2      | Turn ON/OFF Characteristics with Resistive Load .....                      | 14        |
| 5.3      | Inductive Load .....   | 15        |
| 5.3.1    | Output Clamping .....  | 15        |
| 5.3.2    | Maximum Load Inductance .....  | 16        |
| 5.4      | Inverse Current Capability .....   | 16        |
| 5.5      | Electrical Characteristics Power Stage .....                               | 18        |
| <b>6</b> | <b>Protection Functions</b> .....  | <b>20</b> |
| 6.1      | Loss of Ground Protection .....  | 20        |
| 6.2      | Undervoltage Protection .....  | 20        |
| 6.3      | Overvoltage Protection .....   | 21        |
| 6.4      | Reverse Polarity Protection .....  | 22        |
| 6.5      | Overload Protection .....  | 22        |
| 6.5.1    | Current Limitation .....   | 22        |
| 6.5.2    | Temperature Limitation in the Power DMOS .....                             | 23        |
| 6.6      | Electrical Characteristics for the Protection Functions .....              | 25        |
| <b>7</b> | <b>Diagnostic Functions</b> .....  | <b>26</b> |
| 7.1      | IS Pin .....   | 26        |
| 7.2      | SENSE Signal in Different Operating Modes .....                            | 27        |
| 7.3      | SENSE Signal in the Nominal Current Range .....                            | 28        |
| 7.3.1    | SENSE Signal Variation as a Function of Temperature and Load Current ..... | 28        |
| 7.3.2    | SENSE Signal Timing .....  | 29        |
| 7.3.3    | SENSE Signal in Open Load .....  | 30        |
| 7.3.3.1  | Open Load in ON Diagnostic .....   | 30        |
| 7.3.3.2  | Open Load in OFF Diagnostic .....  | 30        |
| 7.3.3.3  | Open Load Diagnostic Timing .....  | 31        |
| 7.3.4    | SENSE Signal with OUT in Short Circuit to $V_S$ .....                      | 32        |
| 7.3.5    | SENSE Signal in Case of Overload .....                                     | 32        |
| 7.3.6    | SENSE Signal in Case of Inverse Current .....                              | 32        |
| 7.4      | Electrical Characteristics Diagnostic Function .....                       | 33        |
| <b>8</b> | <b>Input Pins</b> .....  | <b>35</b> |
| 8.1      | Input Circuitry .....  | 35        |
| 8.2      | DEN Pin .....  | 35        |

---

**Table of Contents**

|           |                                       |           |
|-----------|---------------------------------------|-----------|
| 8.3       | Input Pin Voltage .....               | 35        |
| 8.4       | Electrical Characteristics .....      | 36        |
| <b>9</b>  | <b>Characterization Results .....</b> | <b>37</b> |
| 9.1       | General Product Characteristics ..... | 37        |
| 9.2       | Power Stage .....                     | 38        |
| 9.3       | Protection Functions .....            | 40        |
| 9.4       | Diagnostic Mechanism .....            | 41        |
| 9.5       | Input Pins .....                      | 42        |
| <b>10</b> | <b>Application Information .....</b>  | <b>43</b> |
| 10.1      | Further Application Information ..... | 45        |
| <b>11</b> | <b>Revision History .....</b>         | <b>46</b> |
| <b>12</b> | <b>Package Outlines .....</b>         | <b>47</b> |



## 1 Overview

### Application

- Suitable for resistive, inductive and capacitive loads
- Replaces electromechanical relays, fuses and discrete circuits
- Most suitable for loads with high inrush current, such as lamps
- Suitable for 24V trucks + trailer and transportation systems

### Basic Features

- One channel device
- Very low stand-by current
- 3.3 V and 5 V compatible logic inputs
- Electrostatic discharge protection (ESD)
- Optimized electromagnetic compatibility
- Logic ground independent from load ground
- Very low power DMOS leakage current in OFF state
- Green product (RoHS compliant)
- AEC qualified

### Description

The BTT6010-1EKB is a 10 mΩ single channel Smart High-Side Power Switch, embedded in a PG-DSO-14-47 EP, Exposed Pad package, providing protective functions and diagnosis. The power transistor is built by an N-channel vertical power MOSFET with charge pump. The device is integrated in Smart6 technology. It is specially designed to drive lamps up to 5 x P21W 24V or 1x H55W 12V , as well as LEDs in the harsh automotive environment.

**Table 1 Product Summary**

| Parameter   | Symbol       | Value        |
|---|--------------|--------------|
| Operating voltage range                                   | $V_{S(OP)}$  | 5 V ... 36 V |
| Maximum supply voltage                                    | $V_{S(LD)}$  | 66 V         |
| Maximum ON state resistance at $T_J = 150\text{ °C}$      | $R_{DS(ON)}$ | 22 mΩ        |
| Nominal load current                                      | $I_{L(NOM)}$ | 9 A          |
| Typical current sense ratio                               | $k_{ILIS}$   | 3900         |
| Minimum current limitation                                | $I_{L5(SC)}$ | 68 A         |
| Maximum standby current with load at $T_J = 25\text{ °C}$ | $I_{S(OFF)}$ | 1.4 μA       |

| Type         | Package         | Marking      |
|--------------|-----------------|--------------|
| BTT6010-1EKB | PG-DSO-14-47 EP | BTT6010-1EKB |

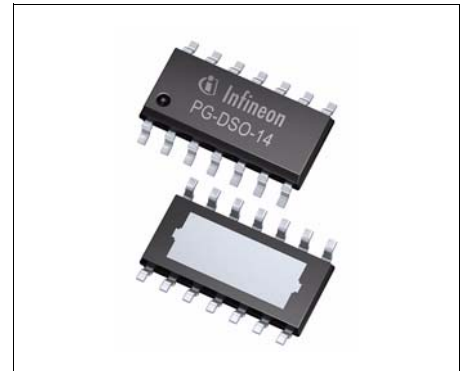

**PG-DSO-14-47 EP**

**Diagnostic Functions**

- Proportional load current sense
- Open load in ON and OFF
- Short circuit to battery and ground
- Overtemperature
- Stable diagnostic signal during short circuit
- Enhanced  $k_{ILIS}$  dependency with temperature and load current

**Protection Functions**

- Stable behavior during undervoltage
- Reverse polarity protection with external components
- Secure load turn-off during logic ground disconnect with external components
- Overtemperature protection with latch
- Overvoltage protection with external components
- Voltage dependent current limitation
- Enhanced short circuit protection for up to 40m cables

## 2 Block Diagram

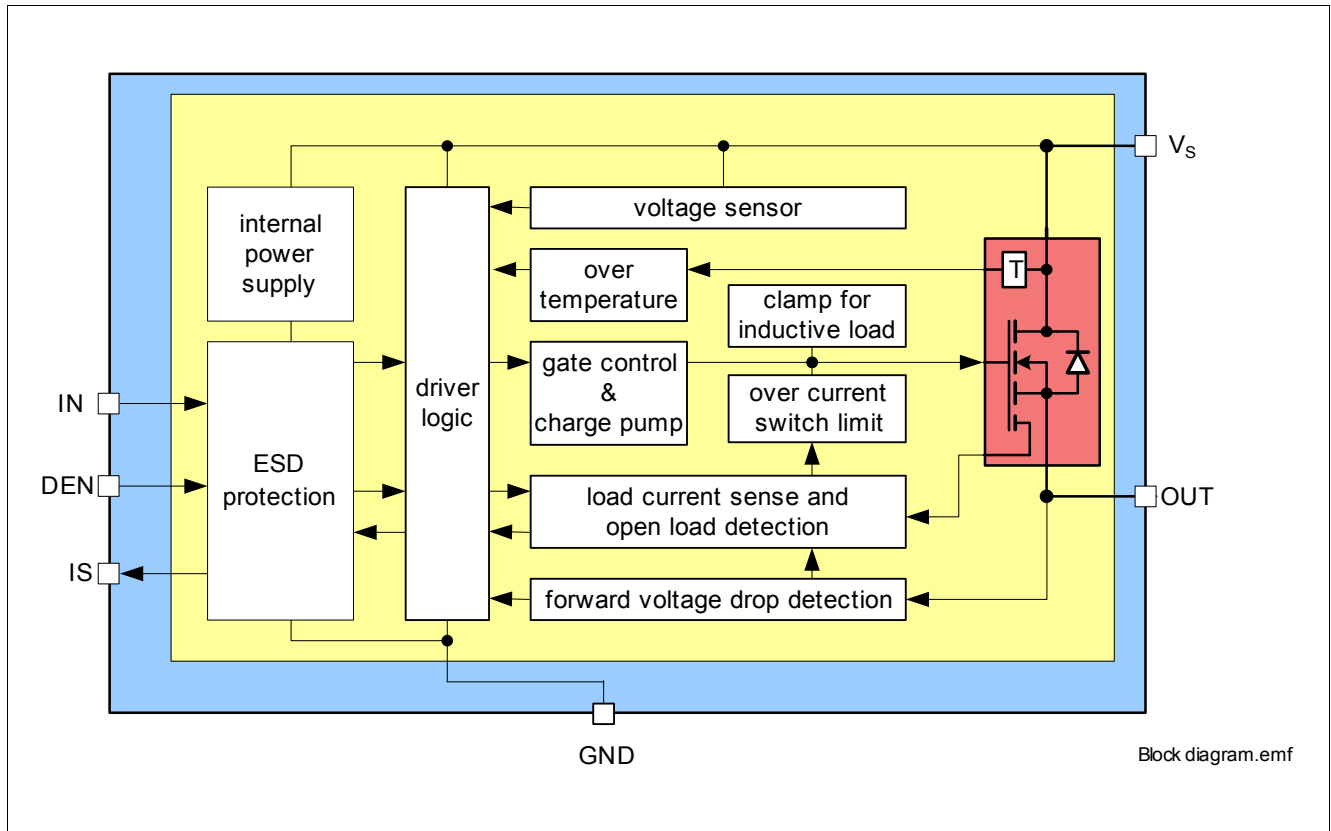

Figure 1 Block Diagram for the BTT6010-1EKB

### 3 Pin Configuration

#### 3.1 Pin Assignment

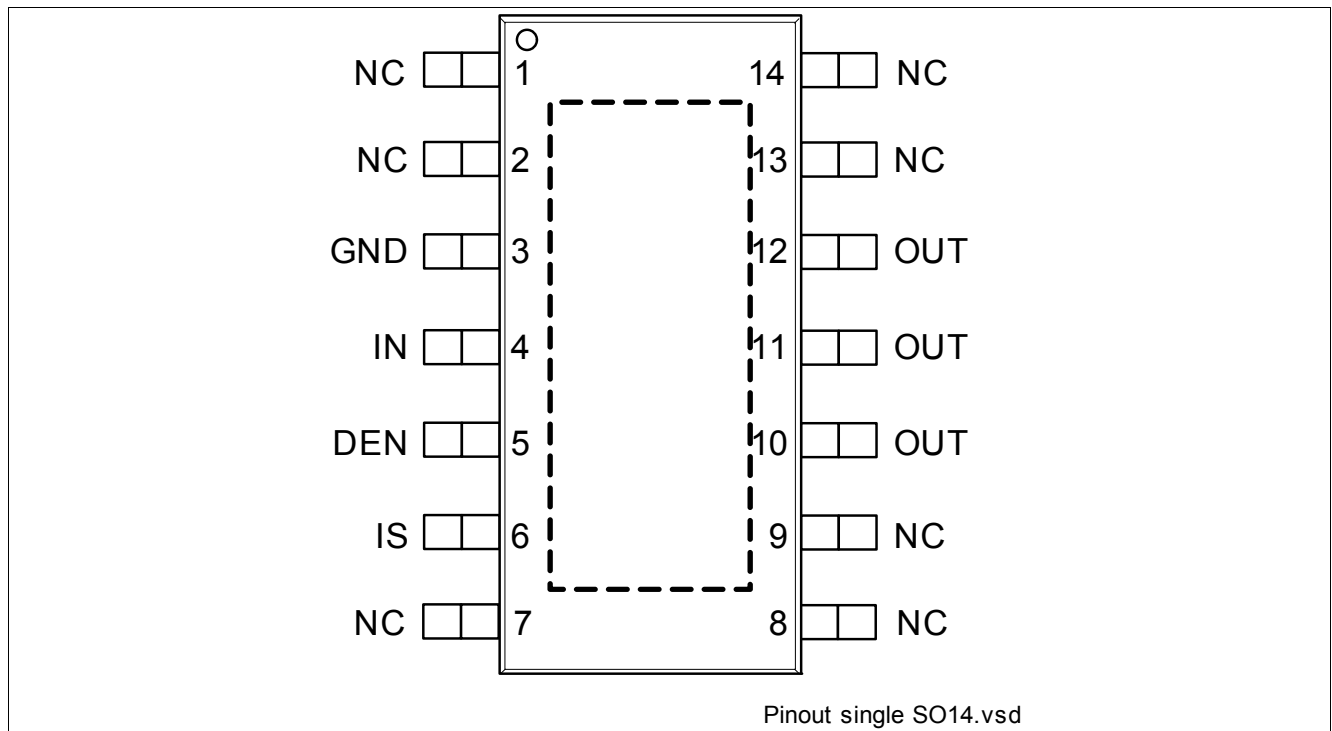

Figure 2 Pin Configuration

#### 3.2 Pin Definitions and Functions

| Pin                   | Symbol | Function  |
|-----------------------|--------|---|
| Cooling Tab           | $V_S$  | <b>Voltage Supply</b> ; Battery voltage   |
| 1, 2, 7, 8, 9, 13, 14 | NC     | <b>Not Connected</b> ; No internal connection to the chip                               |
| 3                     | GND    | <b>GrouND</b> ; Ground connection   |
| 4                     | IN     | <b>INput channel</b> ; Input signal for channel activation                              |
| 5                     | DEN    | <b>Diagnostic ENable</b> ; Digital signal to enable/disable the diagnosis of the device |
| 6                     | IS     | <b>Sense</b> ; Sense current of the selected channel                                    |
| 10, 11, 12            | OUT    | <b>OUTput</b> ; Protected high side power output channel <sup>1)</sup>                  |

1) All output pins must be connected together on the PCB. All pins of the output are internally connected together. PCB traces have to be designed to withstand the maximum current which can flow.



### 3.3 Voltage and Current Definition

Figure 3 shows all terms used in this data sheet, with associated convention for positive values.

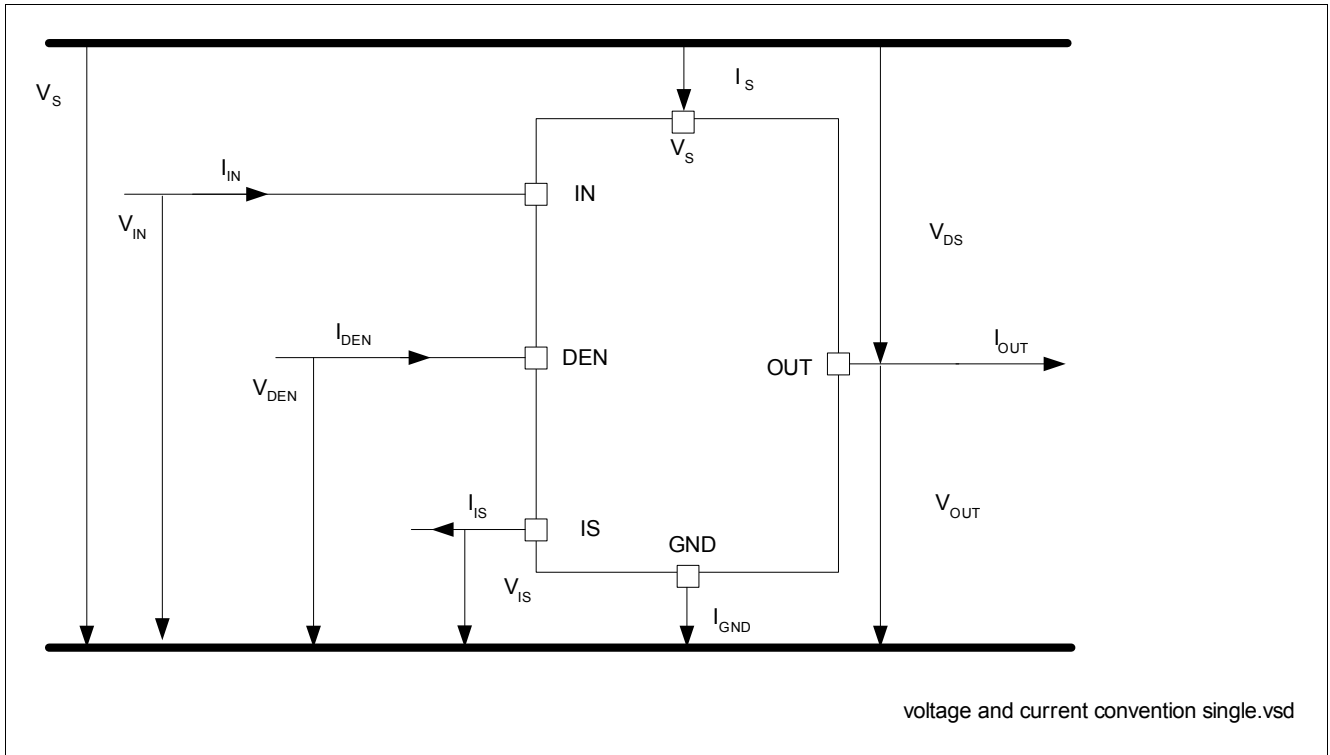

Figure 3 Voltage and Current Definition

## 4 General Product Characteristics

### 4.1 Absolute Maximum Ratings

**Table 2 Absolute Maximum Ratings** <sup>1)</sup>
 $T_J = -40\text{ °C to }+150\text{ °C}$ ; (unless otherwise specified)

| Parameter                                   | Symbol        | Values    |      |              | Unit     | Note / Test Condition  | Number   |
|---|---------------|-----------|------|--------------|----------|--|----------|
|   |               | Min.      | Typ. | Max.         |          |  |          |
| <b>Supply Voltages</b>                      |               |           |      |              |          |  |          |
| Supply voltage                              | $V_S$         | -0.3      | –    | 48           | V        | –  | P_4.1.1  |
| Reverse polarity voltage                    | $-V_{S(REV)}$ | 0         | –    | 28           | V        | $t < 2\text{ min}$<br>$T_A = 25\text{ °C}$<br>$R_L \geq 4\ \Omega$   | P_4.1.2  |
| Supply voltage for short circuit protection | $V_{BAT(SC)}$ | 0         | –    | 36           | V        | $R_{supply} = 10\text{ m}\Omega$<br>$L_{supply} = 5\ \mu\text{H}$<br>$R_{Cable1} = 20\text{ m}\Omega$<br>$L_{Cable1} = 0\ \mu\text{H}$<br>$R_{Cable2} = 320\text{ m}\Omega$<br>$L_{Cable2} = 40\ \mu\text{H}$<br>See <a href="#">Chapter 6</a> and <a href="#">Figure 29</a> | P_4.1.3  |
| Supply voltage for Load dump protection     | $V_{S(LD)}$   | –         | –    | 66           | V        | <sup>2)</sup> $R_I = 2\ \Omega$<br>$R_L = 4\ \Omega$   | P_4.1.12 |
| <b>Short Circuit Capability</b>             |               |           |      |              |          |  |          |
| Permanent short circuit IN pin toggles      | $n_{RSC1}$    |           | –    | 100          | k cycles | <sup>3)</sup> $V_{supply} = 28\text{V}$  | P_4.1.4  |
| <b>Input Pins</b>                           |               |           |      |              |          |  |          |
| Voltage at INPUT pin                        | $V_{IN}$      | -0.3<br>– | –    | 6<br>7       | V        | –<br>$t < 2\text{ min}$  | P_4.1.13 |
| Current through INPUT pin                   | $I_{IN}$      | -2        | –    | 2            | mA       | –  | P_4.1.14 |
| Voltage at DEN pin                          | $V_{DEN}$     | -0.3<br>– | –    | 6<br>7       | V        | –<br>$t < 2\text{ min}$  | P_4.1.15 |
| Current through DEN pin                     | $I_{DEN}$     | -2        | –    | 2            | mA       | –  | P_4.1.16 |
| <b>Sense Pin</b>                            |               |           |      |              |          |  |          |
| Voltage at IS pin                           | $V_{IS}$      | -0.3      | –    | $V_S$        | V        | –  | P_4.1.19 |
| Current through IS pin                      | $I_{IS}$      | -25       | –    | 50           | mA       | –  | P_4.1.20 |
| <b>Power Stage</b>                          |               |           |      |              |          |  |          |
| Load current                                | $ I_L $       | –         | –    | $I_{L(LIM)}$ | A        | –  | P_4.1.21 |
| Power dissipation (DC)                      | $P_{TOT}$     | –         | –    | 1.6          | W        | $T_A = 85\text{ °C}$<br>$T_J < 150\text{ °C}$  | P_4.1.22 |
| Maximum energy dissipation Single pulse     | $E_{AS}$      | –         | –    | 219          | mJ       | $I_{L(0)} = 9\text{ A}$<br>$T_{J(0)} = 150\text{ °C}$<br>$V_S = 28\text{ V}$   | P_4.1.23 |

**Table 2 Absolute Maximum Ratings (cont'd)<sup>1)</sup>**
 $T_J = -40\text{ °C to }+150\text{ °C}$ ; (unless otherwise specified)

| Parameter  | Symbol    | Values      |      |          | Unit | Note / Test Condition   | Number   |
|--|-----------|-------------|------|----------|------|-------------------------|----------|
|  |           | Min.        | Typ. | Max.     |      |                         |          |
| Voltage at power transistor                            | $V_{DS}$  | –           | –    | 66       | V    | –                       | P_4.1.26 |
| <b>Currents</b>  |           |             |      |          |      |                         |          |
| Current through ground pin                             | $I_{GND}$ | -20<br>-200 | –    | 20<br>20 | mA   | –<br>$t < 2\text{ min}$ | P_4.1.27 |
| <b>Temperatures</b>                                    |           |             |      |          |      |                         |          |
| Junction temperature                                   | $T_J$     | -40         | –    | 150      | °C   | –                       | P_4.1.28 |
| Storage temperature                                    | $T_{STG}$ | -55         | –    | 150      | °C   | –                       | P_4.1.30 |
| <b>ESD Susceptibility</b>                              |           |             |      |          |      |                         |          |
| ESD susceptibility (all pins)                          | $V_{ESD}$ | -2          | –    | 2        | kV   | <sup>4)</sup> HBM       | P_4.1.31 |
| ESD susceptibility OUT Pin vs. GND and $V_S$ connected | $V_{ESD}$ | -4          | –    | 4        | kV   | <sup>4)</sup> HBM       | P_4.1.32 |
| ESD susceptibility                                     | $V_{ESD}$ | -500        | –    | 500      | V    | <sup>5)</sup> CDM       | P_4.1.33 |
| ESD susceptibility pin (corner pins)                   | $V_{ESD}$ | -750        | –    | 750      | V    | <sup>5)</sup> CDM       | P_4.1.34 |

1) Not subject to production test. Specified by design.

 2)  $V_{S(LD)}$  is setup without the DUT connected to the generator per ISO 7637-1.

3) Threshold limit for short circuit failures : 100ppm. Please refer to the legal disclaimer for short circuit capability at the end of this document.

4) ESD susceptibility HBM according to ANSI/ESDA/JEDEC JS-001

5) ESD susceptibility, Charge Device Model "CDM" ESDA STM5.3.1 or ANSI/ESD S.5.3.1

**Notes**

1. Stresses above the ones listed here may cause permanent damage to the device. Exposure to absolute maximum rating conditions for extended periods may affect device reliability.
2. Integrated protection functions are designed to prevent IC destruction under fault conditions described in the data sheet. Fault conditions are considered as "outside" normal operating range. Protection functions are not designed for continuous repetitive operation.

## 4.2 Functional Range

**Table 3 Functional Range  $T_J = -40\text{ °C}$  to  $+150\text{ °C}$ ; (unless otherwise specified)**

| Parameter   | Symbol            | Values |      |      | Unit          | Note / Test Condition   | Number   |
|---|-------------------|--------|------|------|---------------|---|----------|
|   |                   | Min.   | Typ. | Max. |               |   |          |
| Nominal operating voltage                                     | $V_{NOM}$         | 8      | 28   | 36   | V             | –   | P_4.2.1  |
| Extended operating voltage                                    | $V_{S(OP)}$       | 5      | –    | 48   | V             | <sup>2)</sup> $V_{IN} = 4.5\text{ V}$<br>$R_L = 4\ \Omega$<br>$V_{DS} < 0.5\text{ V}$<br>See <a href="#">Figure 15</a>  | P_4.2.2  |
| Minimum functional supply voltage                             | $V_{S(OP\_MIN)}$  | 3.8    | 4.3  | 5    | V             | <sup>1)</sup> $V_{IN} = 4.5\text{ V}$<br>$R_L = 4\ \Omega$<br>From $I_{OUT} = 0\text{ A}$<br>to $V_{DS} < 0.5\text{ V}$ ;<br>See <a href="#">Figure 15</a>  | P_4.2.3  |
| Undervoltage shutdown   | $V_{S(UV)}$       | 3      | 3.5  | 4.1  | V             | <sup>1)</sup> $V_{IN} = 4.5\text{ V}$<br>$V_{DEN} = 0\text{ V}$<br>$R_L = 4\ \Omega$<br>From $V_{DS} < 1\text{ V}$ ;<br>to $I_{OUT} = 0\text{ A}$<br>See <a href="#">Figure 15</a><br>See <a href="#">Chapter 9</a> | P_4.2.4  |
| Undervoltage shutdown hysteresis                              | $V_{S(UV\_HYS)}$  | –      | 850  | –    | mV            | <sup>2)</sup> –   | P_4.2.13 |
| Operating current channel active                              | $I_{GND\_1}$      | –      | 4.8  | 9    | mA            | $V_{IN} = 5.5\text{ V}$<br>$V_{DEN} = 5.5\text{ V}$<br>Device in $R_{DS(ON)}$<br>$V_S = 36\text{ V}$<br>See <a href="#">Chapter 9</a>   | P_4.2.5  |
| Standby current for whole device with load (ambiente)         | $I_{S(OFF)}$      | –      | 0.1  | 0.5  | $\mu\text{A}$ | <sup>1)</sup> $V_S = 36\text{ V}$<br>$V_{OUT} = 0\text{ V}$<br>$V_{IN}$ floating<br>$V_{DEN}$ floating<br>$T_J \leq 85\text{ °C}$<br>See <a href="#">Chapter 9</a>  | P_4.2.7  |
| Maximum standby current for whole device with load            | $I_{S(OFF\_150)}$ | –      | 8    | 15   | $\mu\text{A}$ | $V_S = 36\text{ V}$<br>$V_{OUT} = 0\text{ V}$<br>$V_{IN}$ floating<br>$V_{DEN}$ floating<br>$T_J = 150\text{ °C}$<br>See <a href="#">Chapter 9</a>  | P_4.2.10 |
| Standby current for whole device with load, diagnostic active | $I_{S(OFF\_DEN)}$ | –      | 0.6  | –    | mA            | <sup>2)</sup> $V_S = 36\text{ V}$<br>$V_{OUT} = 0\text{ V}$<br>$V_{IN}$ floating<br>$V_{DEN} = 5.5\text{ V}$  | P_4.2.8  |

 1) Test at  $T_J = -40\text{ °C}$  only

2) Not subject to production test. Specified by design.

Note: Within the functional range the IC operates as described in the circuit description. The electrical characteristics are specified within the conditions given in the related electrical characteristics table.

### 4.3 Thermal Resistance

Table 4 Thermal Resistance

| Parameter                   | Symbol     | Values |      |      | Unit | Note / Test Condition | Number  |
|-----------------------------|------------|--------|------|------|------|-----------------------|---------|
|                             |            | Min.   | Typ. | Max. |      |                       |         |
| Junction to soldering point | $R_{thJS}$ | –      | 5    | –    | K/W  | 1)                    | P_4.3.1 |
| Junction to ambient         | $R_{thJA}$ | –      | 28   | –    | K/W  | 1) 2)                 | P_4.3.2 |

- 1) Not subject to production test. Specified by design.
- 2) Specified  $R_{thja}$  value is according to JEDEC JESD51-2,-5,-7 at natural convection on FR4 2s2p board; The product (chip + package) was simulated on a 76.4 x 114.3 x 1.5 mm board with 2 inner copper layers (2 x 70µm Cu, 2 x 35 µm Cu). Where applicable, a thermal via array under the exposed pad contacts the first inner copper layer. Please refer to [Figure 4](#).

#### 4.3.1 PCB set up

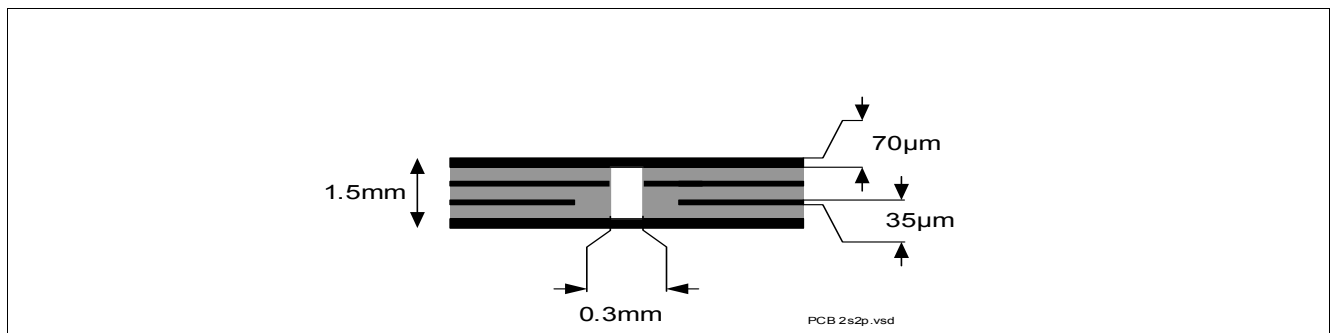

Figure 4 2s2p PCB Cross Section

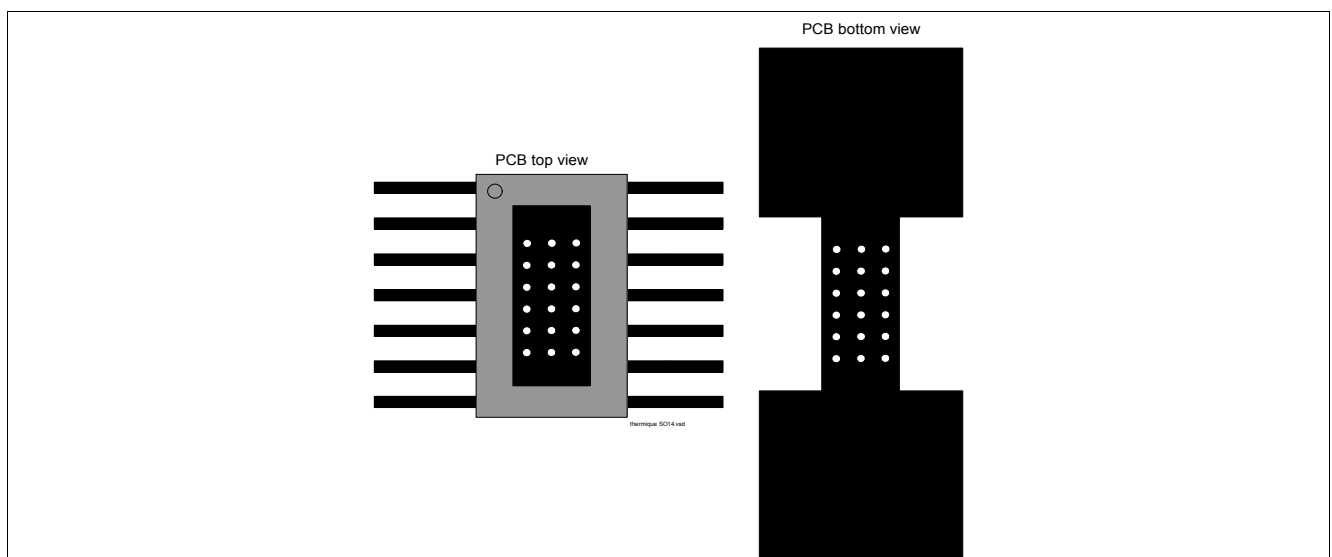

Figure 5 PC Board Top and Bottom View for Thermal Simulation with 600 mm<sup>2</sup> Cooling Area

### 4.3.2 Thermal Impedance

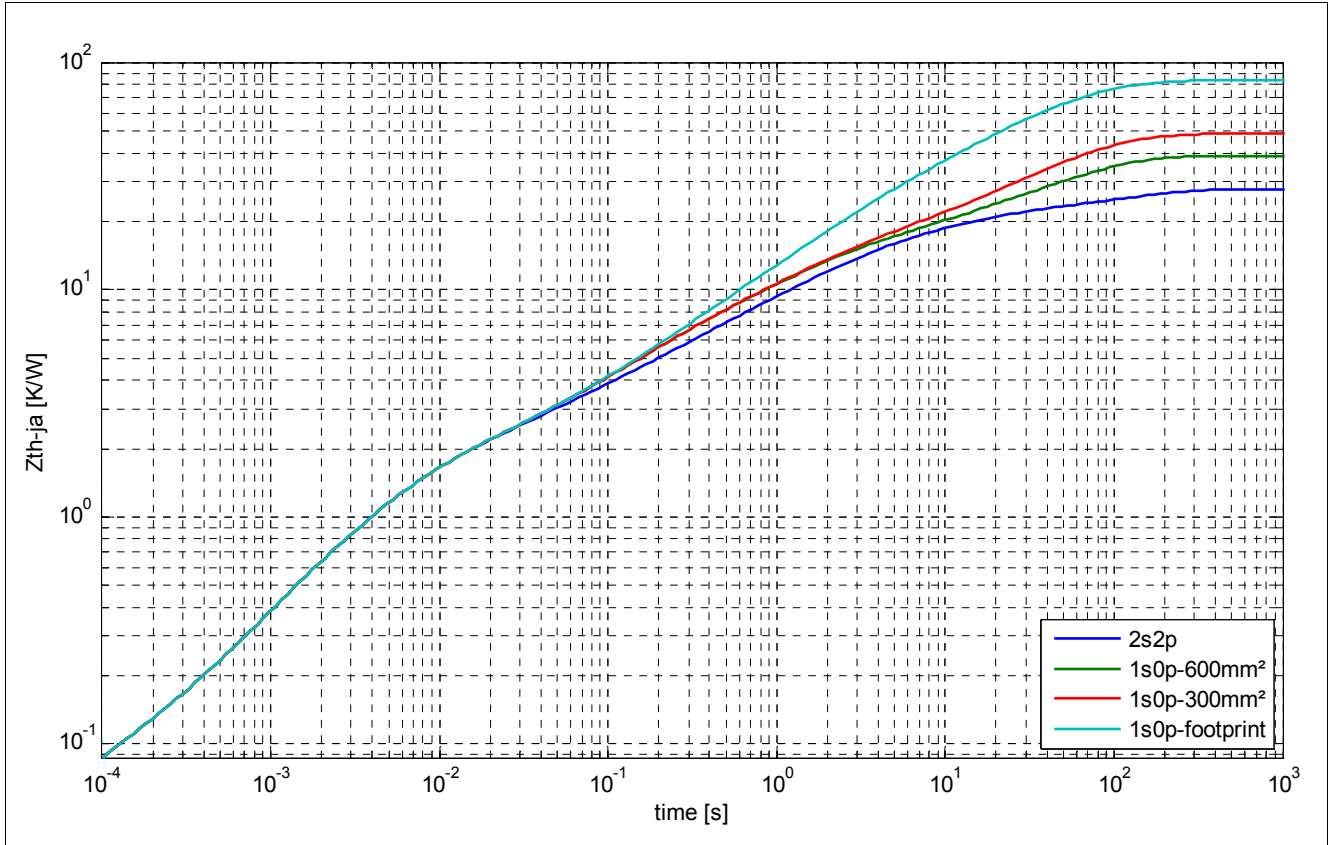

Figure 6 Typical Thermal Impedance. 2s2p PCB set up according Figure 4

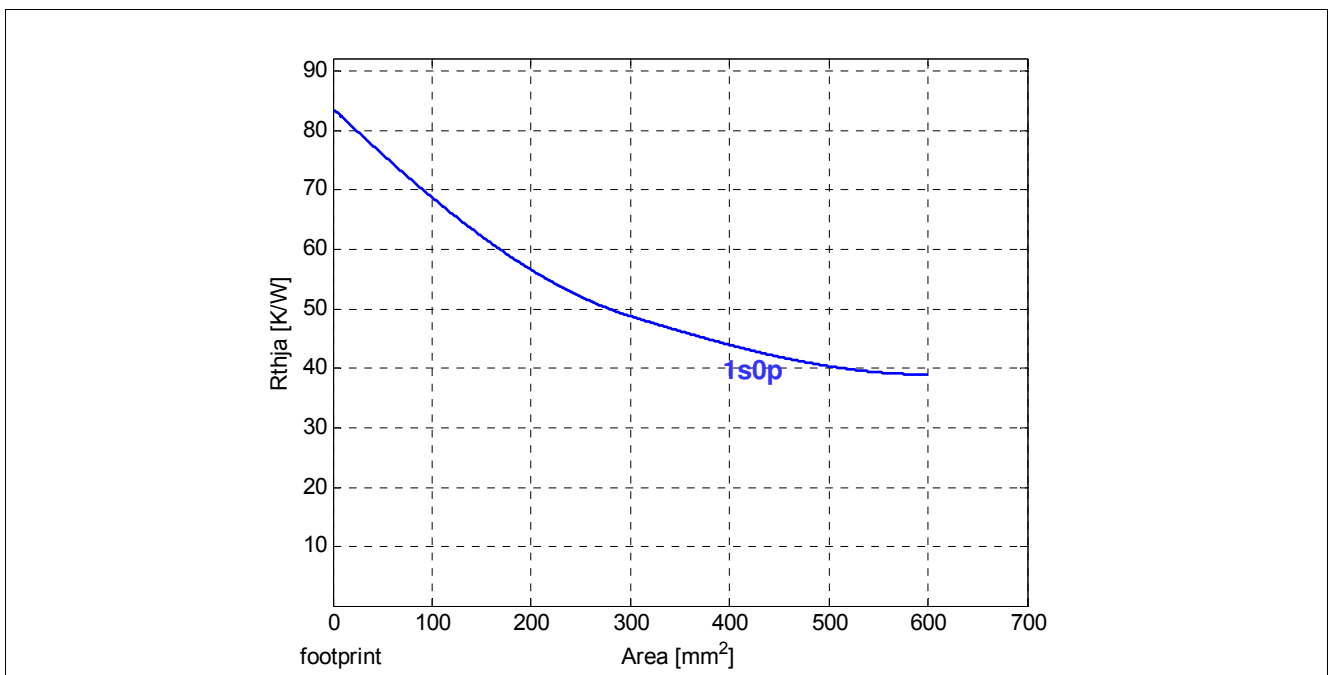

Figure 7 Typical Thermal Resistance. PCB set up 1s0p

## 5 Power Stage

The power stage is built using an N-channel vertical power MOSFET (DMOS) with charge pump.

### 5.1 Output ON-state Resistance

The ON-state resistance  $R_{DS(ON)}$  depends on the supply voltage as well as the junction temperature  $T_J$ . **Figure 8** shows the dependencies in terms of temperature and supply voltage for the typical ON-state resistance. The behavior in reverse polarity is described in **Chapter 6.4**.

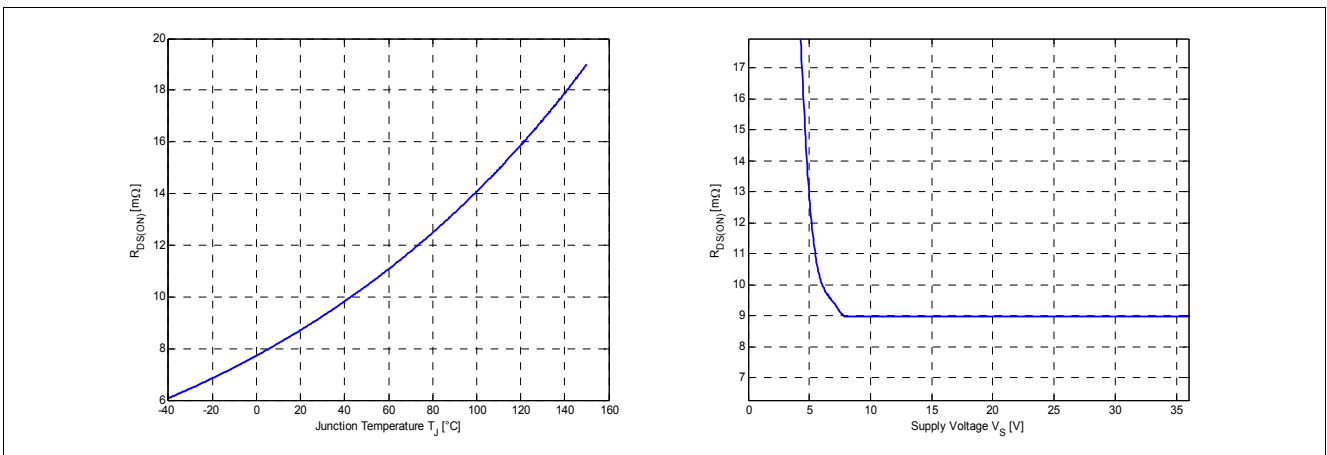
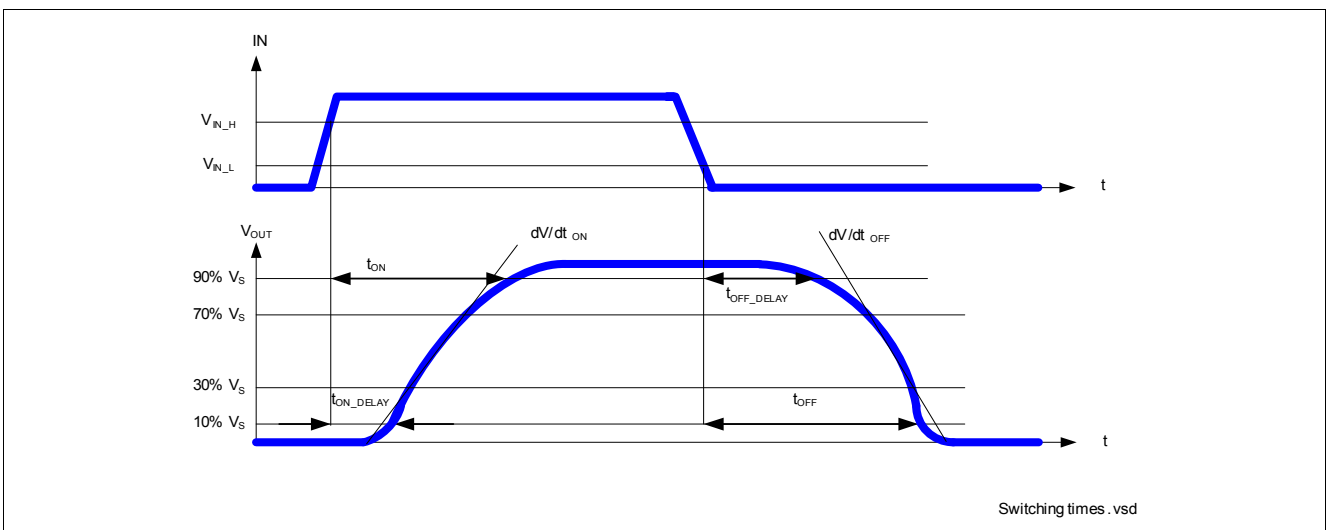

**Figure 8** Typical ON-state Resistance

A high signal (see **Chapter 8**) at the input pin causes the power DMOS to switch ON with a dedicated slope, which is optimized in terms of EMC emission.

### 5.2 Turn ON/OFF Characteristics with Resistive Load

**Figure 9** shows the typical timing when switching a resistive load.



**Figure 9** Switching a Resistive Load Timing

### 5.3 Inductive Load

#### 5.3.1 Output Clamping

When switching OFF inductive loads with high side switches, the voltage  $V_{OUT}$  drops below ground potential, because the inductance intends to continue driving the current. To prevent the destruction of the device by avalanche due to high voltages, there is a voltage clamp mechanism  $Z_{DS(AZ)}$  implemented that limits negative output voltage to a certain level ( $V_S - V_{DS(AZ)}$ ). Please refer to **Figure 10** and **Figure 11** for details. Nevertheless, the maximum allowed load inductance is limited.

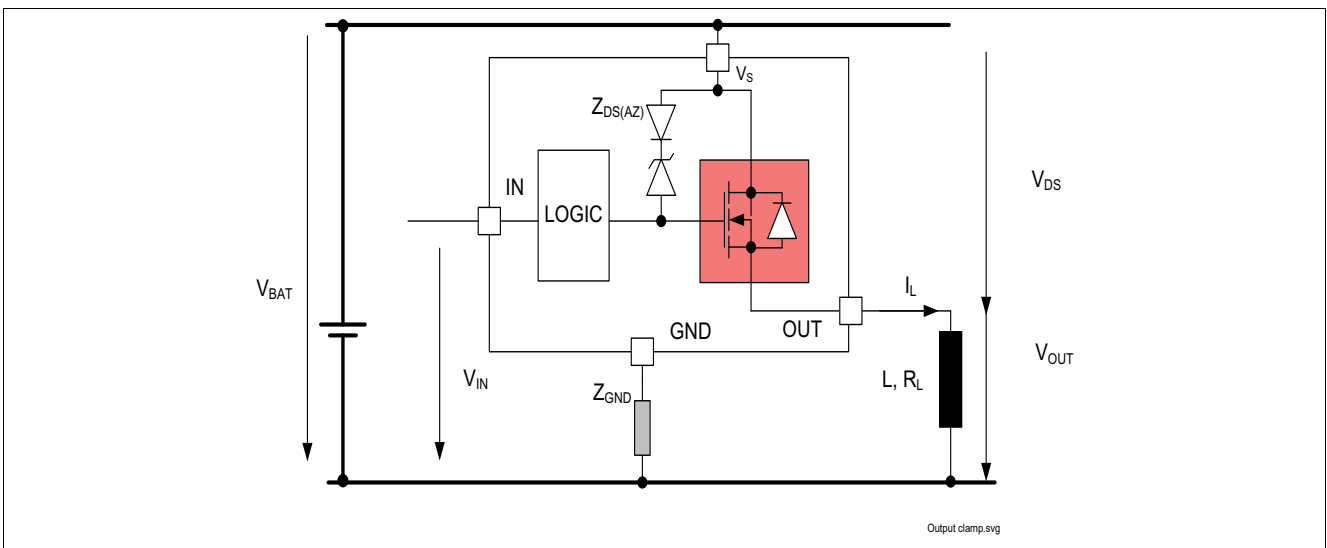

Figure 10 Output Clamp

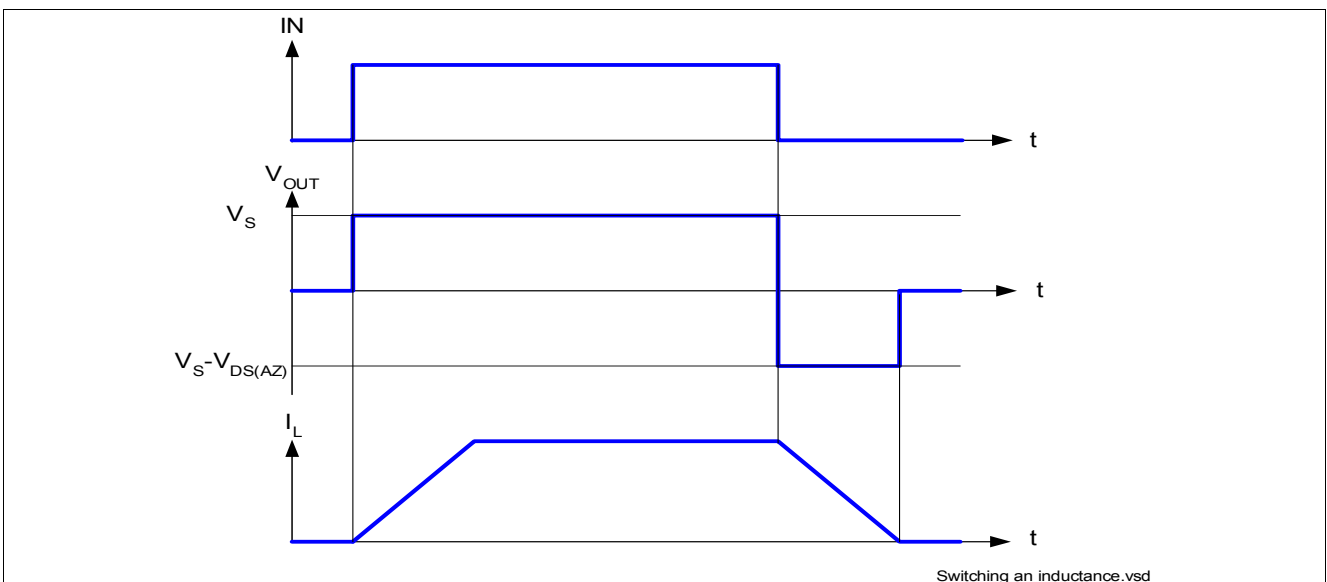

Figure 11 Switching an Inductive Load Timing



### 5.3.2 Maximum Load Inductance

During demagnetization of inductive loads, energy has to be dissipated in the BTT6010-1EKB. This energy can be calculated with following equation:

$$E = V_{DS(AZ)} \times \frac{L}{R_L} \times \left[ \frac{V_S - V_{DS(AZ)}}{R_L} \times \ln \left( 1 - \frac{R_L \times I_L}{V_S - V_{DS(AZ)}} \right) + I_L \right] \quad (1)$$

Following equation simplifies under the assumption of  $R_L = 0 \Omega$ .

$$E = \frac{1}{2} \times L \times I^2 \times \left( 1 - \frac{V_S}{V_S - V_{DS(AZ)}} \right) \quad (2)$$

The energy, which is converted into heat, is limited by the thermal design of the component. See **Figure 12** for the maximum allowed energy dissipation as a function of the load current.

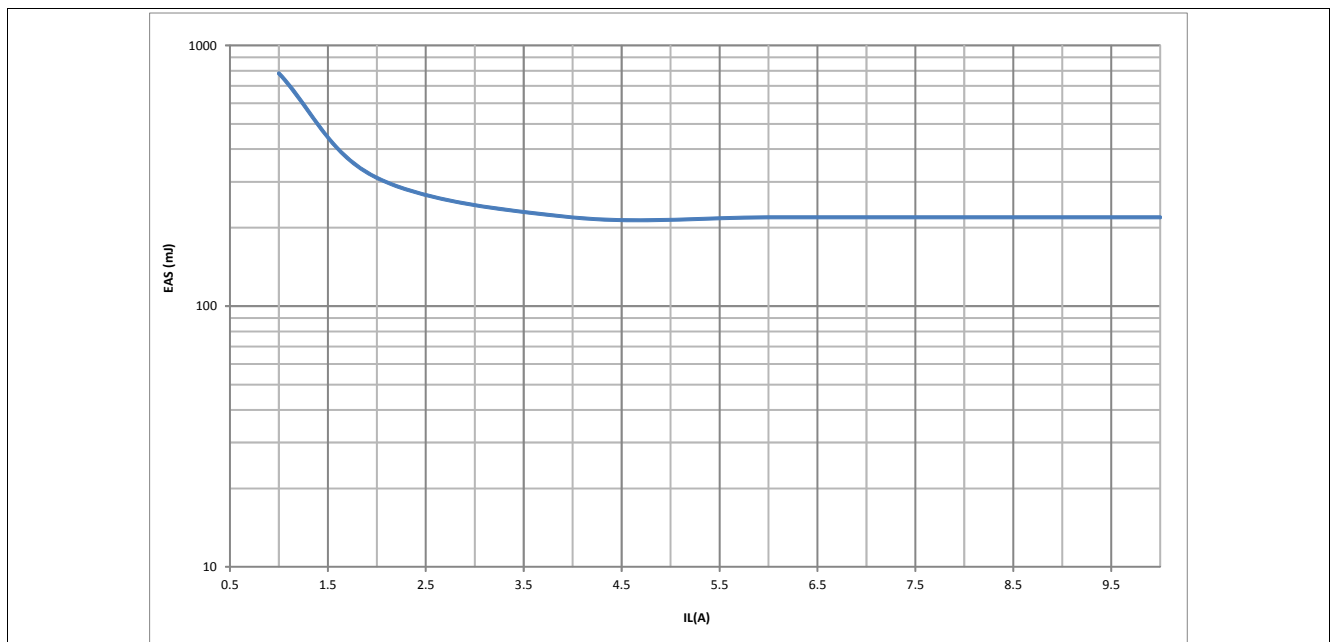

Figure 12 Maximum Energy Dissipation Single Pulse,  $T_{J\_START} = 150 \text{ }^\circ\text{C}$ ;  $V_S = 28\text{V}$

### 5.4 Inverse Current Capability

In case of inverse current, meaning a voltage  $V_{INV}$  at the OUTput higher than the supply voltage  $V_S$ , a current  $I_{INV}$  will flow from output to  $V_S$  pin via the body diode of the power transistor (please refer to **Figure 13**). The output stage follows the state of the IN pin, except if the IN pin goes from OFF to ON during inverse. In that particular case, the output stage is kept OFF until the inverse current disappears. Nevertheless, the current  $I_{INV}$  should not be higher than  $I_{L(INV)}$ . If the channel is OFF, the diagnostic will detect an open load at OFF. If the affected channel is ON, the diagnostic will detect open load at ON (the overtemperature signal is inhibited). At the appearance of  $V_{INV}$ , a parasitic diagnostic can be observed. After, the diagnosis is valid and reflects the output state. At  $V_{INV}$  vanishing, the diagnosis is valid and reflects the output state. During inverse current, no protection functions are available.

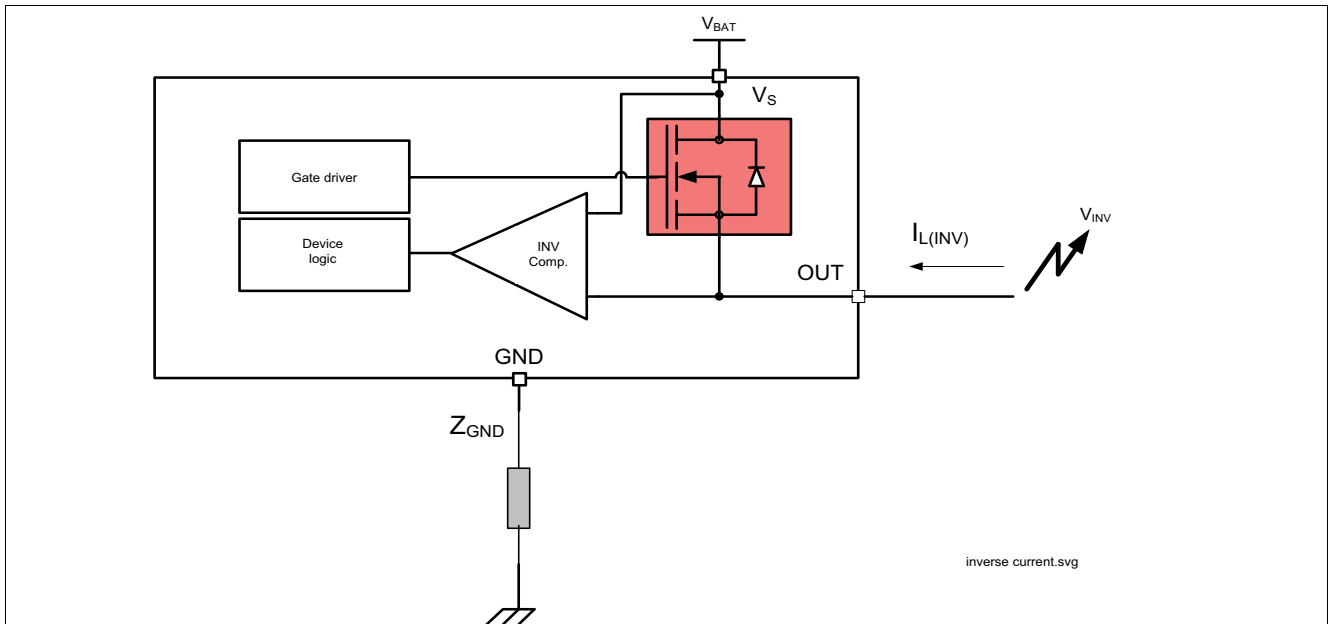

Figure 13 Inverse Current Circuitry

## 5.5 Electrical Characteristics Power Stage

**Table 5 Electrical Characteristics: Power Stage**
 $V_S = 8\text{ V to }36\text{ V}$ ,  $T_J = -40\text{ °C to }+150\text{ °C}$  (unless otherwise specified).

 Typical values are given at  $V_S = 28\text{ V}$ ,  $T_J = 25\text{ °C}$ 

| Parameter  | Symbol           | Values |      |      | Unit | Note / Test Condition  | Number   |
|--|------------------|--------|------|------|------|--|----------|
|  |                  | Min.   | Typ. | Max. |      |  |          |
| ON-state resistance per channel                                    | $R_{DS(ON)_150}$ | 15     | 20   | 22   | mΩ   | $I_L = I_{L4} = 10\text{ A}$<br>$V_{IN} = 4.5\text{ V}$<br>$T_J = 150\text{ °C}$<br>See <a href="#">Figure 8</a> | P_5.5.1  |
| ON-state resistance per channel                                    | $R_{DS(ON)_25}$  | –      | 10   | –    | mΩ   | <sup>1)</sup> $T_J = 25\text{ °C}$   | P_5.5.21 |
| Nominal load current   | $I_{L(NOM)}$     | –      | 9    | –    | A    | <sup>1)</sup> $T_A = 85\text{ °C}$<br>$T_J < 150\text{ °C}$  | P_5.5.2  |
| Output voltage drop limitation at small load currents              | $V_{DS(NL)}$     | –      | 10   | 22   | mV   | $I_L = I_{L0} = 50\text{ mA}$<br>See <a href="#">Chapter 9</a>   | P_5.5.4  |
| Drain to source clamping voltage<br>$V_{DS(AZ)} = [V_S - V_{OUT}]$ | $V_{DS(AZ)}$     | 66     | 70   | 75   | V    | $I_{DS} = 20\text{ mA}$<br>See <a href="#">Figure 11</a><br>See <a href="#">Chapter 9</a>                        | P_5.5.5  |
| Output leakage current<br>$T_J \leq 85\text{ °C}$                  | $I_{L(OFF)}$     | –      | 0.05 | 0.5  | μA   | <sup>2)</sup> $V_{IN}$ floating<br>$V_{OUT} = 0\text{ V}$<br>$T_J \leq 85\text{ °C}$                             | P_5.5.6  |
| Output leakage current<br>$T_J = 150\text{ °C}$                    | $I_{L(OFF)_150}$ | –      | 8    | 15   | μA   | $V_{IN}$ floating<br>$V_{OUT} = 0\text{ V}$<br>$T_J = 150\text{ °C}$   | P_5.5.8  |
| Slew rate<br>30% to 70% $V_S$                                      | $dV/dt_{ON}$     | 0.3    | 0.65 | 1.4  | V/μs | $R_L = 4\text{ Ω}$<br>$V_S = 28\text{ V}$  | P_5.5.11 |
| Slew rate<br>70% to 30% $V_S$                                      | $-dV/dt_{OFF}$   | 0.3    | 0.65 | 1.4  | V/μs | See <a href="#">Figure 9</a><br>See <a href="#">Chapter 9</a>  | P_5.5.12 |
| Slew rate matching<br>$dV/dt_{ON} - dV/dt_{OFF}$                   | $\Delta dV/dt$   | -0.15  | 0    | 0.15 | V/μs |  | P_5.5.13 |
| Turn-ON time to $V_{OUT} = 90\%$<br>$V_S$                          | $t_{ON}$         | 20     | 70   | 150  | μs   |  | P_5.5.14 |
| Turn-OFF time to $V_{OUT} = 10\%$<br>$V_S$                         | $t_{OFF}$        | 20     | 70   | 150  | μs   |  | P_5.5.15 |
| Turn-ON / OFF matching<br>$t_{OFF} - t_{ON}$                       | $\Delta t_{SW}$  | -50    | 0    | 50   | μs   |  | P_5.5.16 |
| Turn-ON time to $V_{OUT} = 10\%$<br>$V_S$                          | $t_{ON\_delay}$  | –      | 35   | 70   | μs   |  | P_5.5.17 |
| Turn-OFF time to $V_{OUT} = 90\%$<br>$V_S$                         | $t_{OFF\_delay}$ | –      | 35   | 70   | μs   |  | P_5.5.18 |

**Table 5 Electrical Characteristics: Power Stage (cont'd)**

$V_S = 8\text{ V to }36\text{ V}$ ,  $T_J = -40\text{ °C to }+150\text{ °C}$  (unless otherwise specified).  
 Typical values are given at  $V_S = 28\text{ V}$ ,  $T_J = 25\text{ °C}$

| Parameter         | Symbol    | Values |      |      | Unit | Note / Test Condition   | Number   |
|-------------------|-----------|--------|------|------|------|---|----------|
|                   |           | Min.   | Typ. | Max. |      |   |          |
| Switch ON energy  | $E_{ON}$  | –      | 2.1  | –    | mJ   | <sup>1)</sup> $R_L = 4\ \Omega$<br>$V_{OUT} = 90\% V_S$<br>$V_S = 36\text{ V}$<br>See <a href="#">Chapter 9</a> | P_5.5.19 |
| Switch OFF energy | $E_{OFF}$ | –      | 2.3  | –    | mJ   | <sup>1)</sup> $R_L = 4\ \Omega$<br>$V_{OUT} = 10\% V_S$<br>$V_S = 36\text{ V}$<br>See <a href="#">Chapter 9</a> | P_5.5.20 |

- 1) Not subject to production test, specified by design.
- 2) Test at  $T_J = -40\text{ °C}$  only

## 6 Protection Functions

The device provides integrated protection functions. These functions are designed to prevent the destruction of the IC from fault conditions described in the data sheet. Fault conditions are considered as “outside” normal operating range. Protection functions are designed for neither continuous nor repetitive operation.

### 6.1 Loss of Ground Protection

In case of loss of the module ground and the load remains connected to ground, the device protects itself by automatically turning OFF (when it was previously ON) or remains OFF, regardless of the voltage applied on IN pin.

In case of loss of device ground, it's recommended to use input resistors between the microcontroller and the BTT6010-1EKB to ensure switching OFF of the channel.

In case of loss of module or device ground, a current ( $I_{OUT(GND)}$ ) can flow out of the DMOS. **Figure 14** sketches the situation.

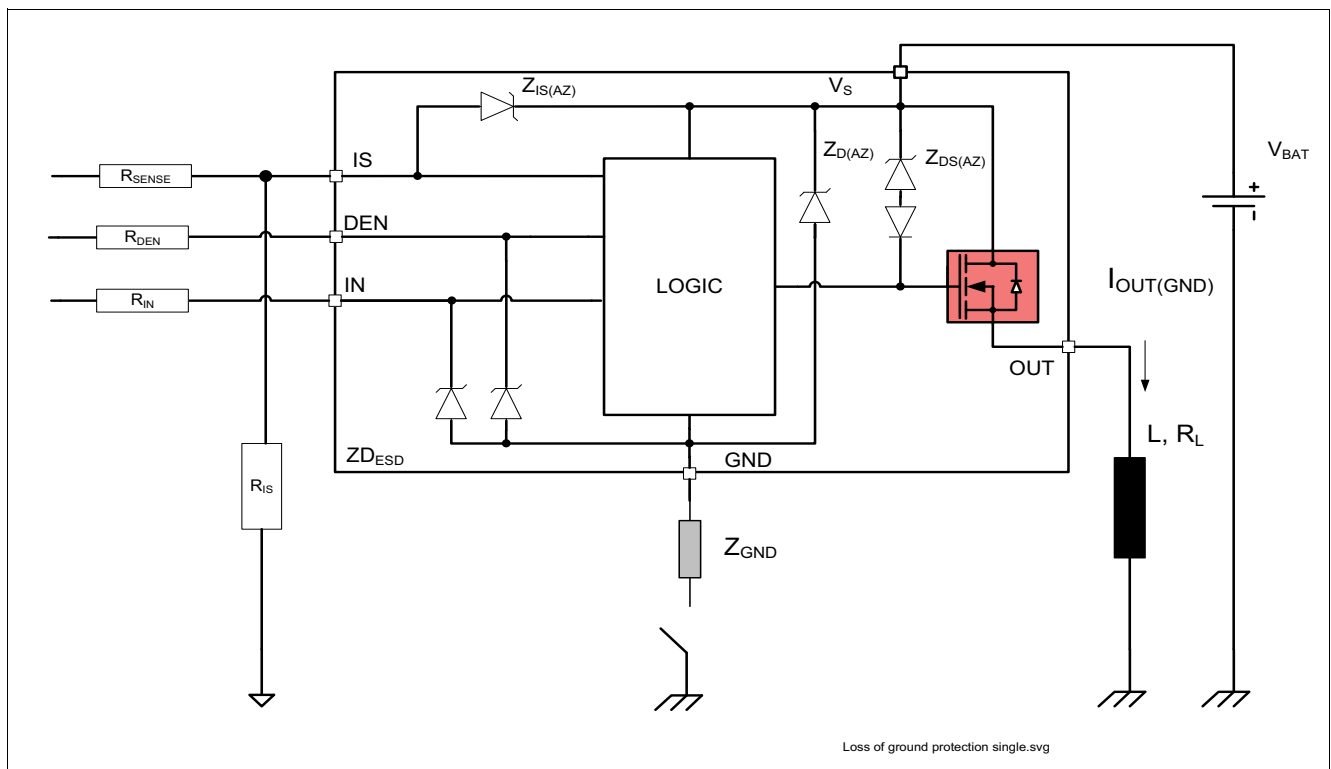

**Figure 14 Loss of Ground Protection with External Components**

### 6.2 Undervoltage Protection

Between  $V_{S(UV)}$  and  $V_{S(OP)}$ , the undervoltage mechanism is triggered.  $V_{S(OP)}$  represents the minimum voltage where the switching ON and OFF can take place.  $V_{S(UV)}$  represents the minimum voltage the switch can hold ON. If the supply voltage is below the undervoltage mechanism  $V_{S(UV)}$ , the device is OFF (turns OFF). As soon as the supply voltage is above the undervoltage mechanism  $V_{S(OP)}$ , then the device can be switched ON. When the switch is ON, protection functions are operational. Nevertheless, the diagnosis is not guaranteed until  $V_S$  is in the  $V_{NOM}$  range. **Figure 15** sketches the undervoltage mechanism.

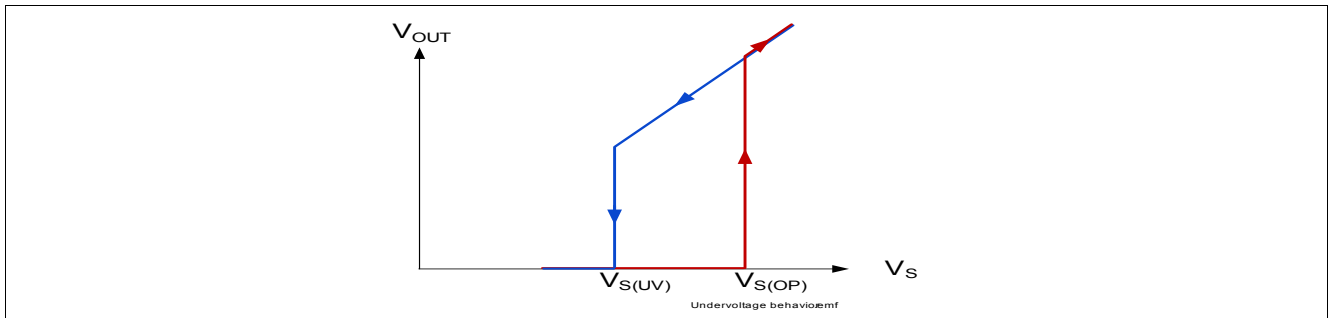

Figure 15 Undervoltage Behavior

### 6.3 Overvoltage Protection

There is an integrated clamp mechanism for overvoltage protection ( $Z_{D(AZ)}$ ). To guarantee this mechanism operates properly in the application, the current in the Zener diode has to be limited by a ground resistor. **Figure 16** shows a typical application to withstand overvoltage issues. In case of supply voltage higher than  $V_{S(AZ)}$ , the power transistor switches ON and in addition the voltage across the logic section is clamped. As a result, the internal ground potential rises to  $V_S - V_{S(AZ)}$ . Due to the ESD Zener diodes, the potential at pin IN and DEN rises almost to that potential, depending on the impedance of the connected circuitry. In the case the device was ON, prior to overvoltage, the BTT6010-1EKB remains ON. In the case the BTT6010-1EKB was OFF, prior to overvoltage, the power transistor can be activated. In the case the supply voltage is in above  $V_{BAT(SC)}$  and below  $V_{DS(AZ)}$ , the output transistor is still operational and follows the input. If the channel is in the ON state, parameters are no longer guaranteed and lifetime is reduced compared to the nominal supply voltage range. This especially impacts the short circuit robustness, as well as the maximum energy  $E_{AS}$  capability.

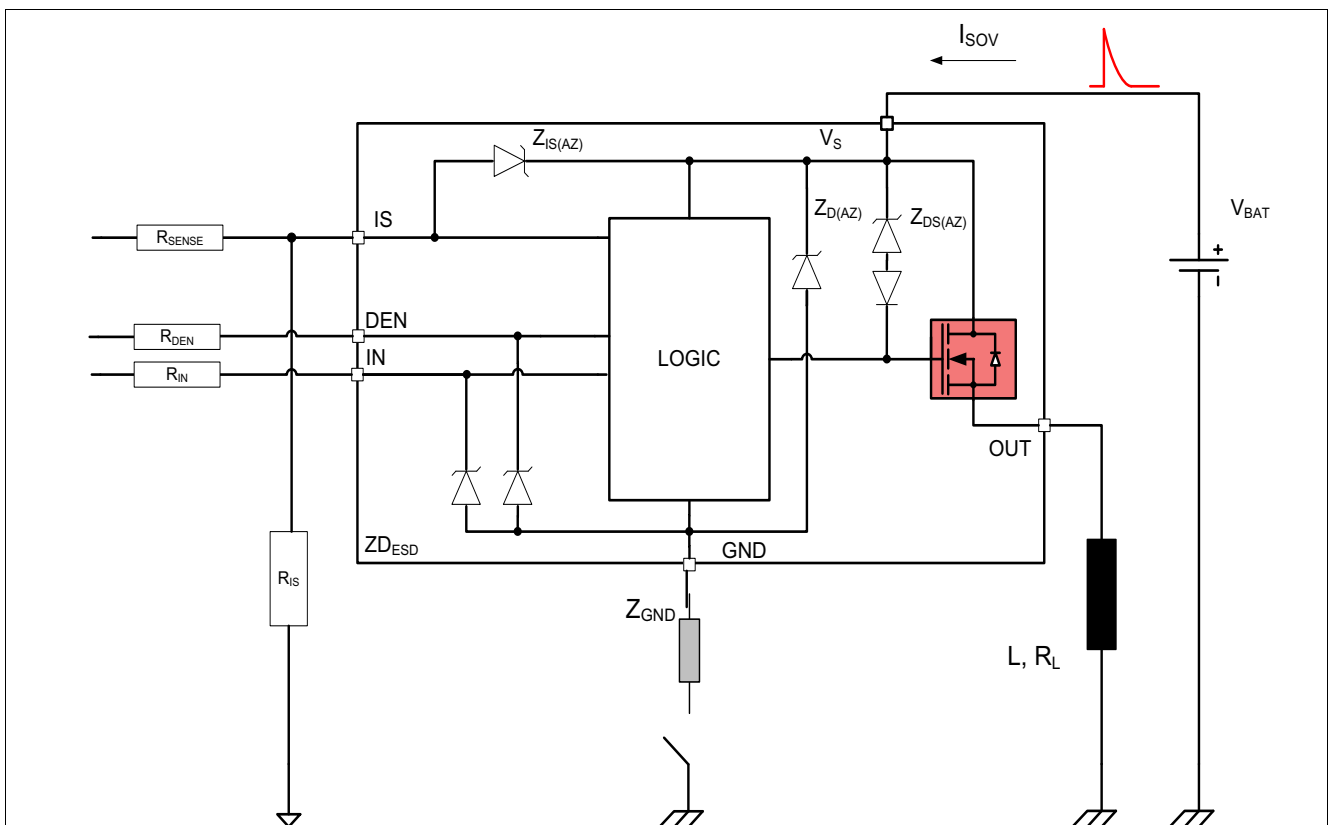

Figure 16 Overvoltage Protection with External Components



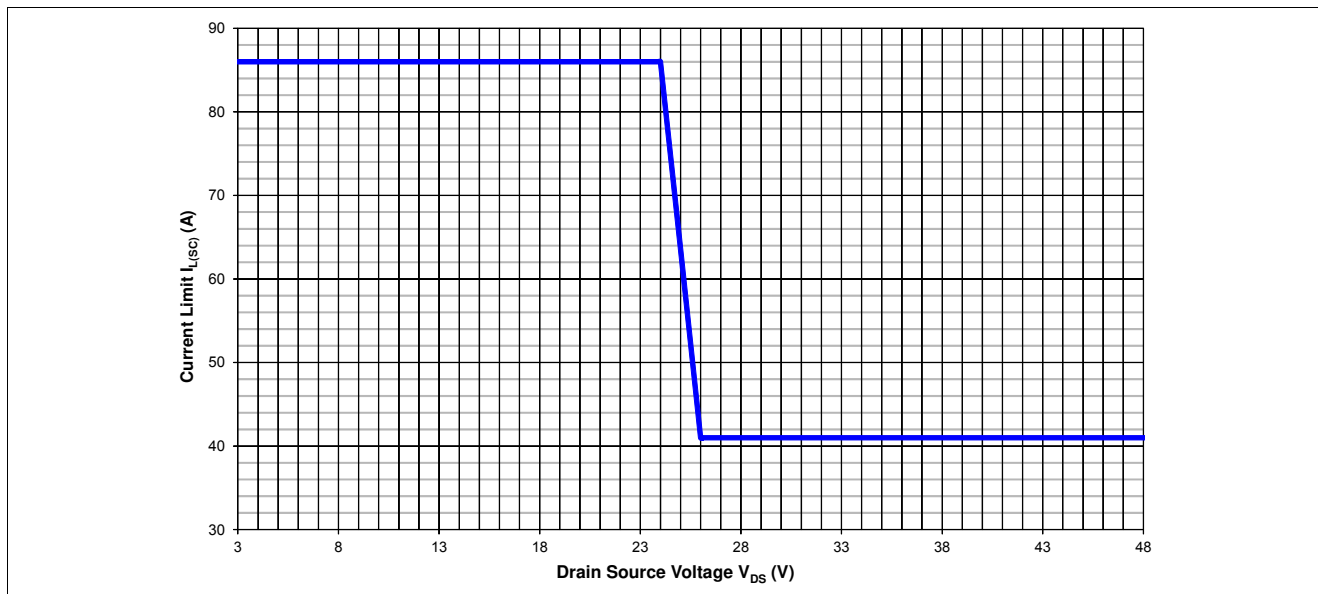

Figure 18 Current Limitation (typical behavior)

### 6.5.2 Temperature Limitation in the Power DMOS

The channel incorporates both an absolute ( $T_{J(SC)}$ ) and a dynamic ( $T_{J(SW)}$ ) temperature sensor. Activation of either sensor will cause an overheated channel to switch OFF to prevent destruction. Any protective switch OFF latches the output until the temperature has reached an acceptable value. **Figure 19** gives a sketch of the situation.

No retry strategy is implemented such that when the DMOS temperature has cooled down enough, the switch is switched ON again. Only the IN pin signal toggling can re-activate the power stage (latch behavior).



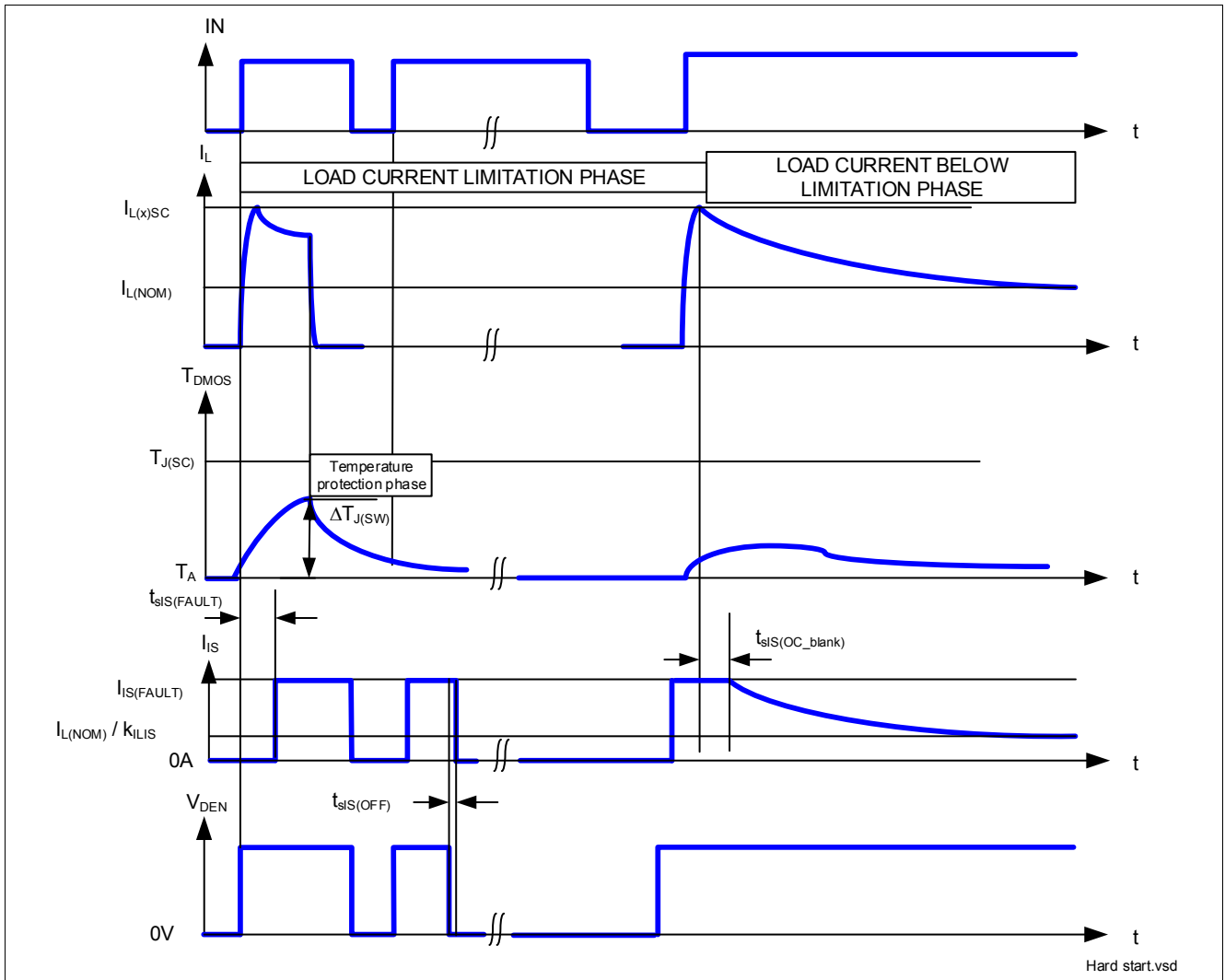

**Figure 19 Overload Protection**

*Note: For better understanding, the time scale is not linear. The real timing of this drawing is application dependant and cannot be described.*

## 6.6 Electrical Characteristics for the Protection Functions

**Table 6 Electrical Characteristics: Protection**
 $V_S = 8\text{ V to }36\text{ V}$ ,  $T_J = -40\text{ °C to }+150\text{ °C}$  (unless otherwise specified).

 Typical values are given at  $V_S = 28\text{ V}$ ,  $T_J = 25\text{ °C}$ 

| Parameter  | Symbol             | Values |                   |                   | Unit | Note / Test Condition   | Number   |
|--|--------------------|--------|-------------------|-------------------|------|---|----------|
|  |                    | Min.   | Typ.              | Max.              |      |   |          |
| <b>Loss of Ground</b>                              |                    |        |                   |                   |      |   |          |
| Output leakage current while GND disconnected      | $I_{OUT(GND)}$     | –      | 0.1               | –                 | mA   | <sup>1) 2)</sup> $V_S = 48\text{ V}$<br>See <a href="#">Figure 14</a>         | P_6.6.1  |
| <b>Reverse Polarity</b>                            |                    |        |                   |                   |      |   |          |
| Drain source diode voltage during reverse polarity | $V_{DS(REV)}$      | 420    | 650               | 700               | mV   | $I_L = -4\text{ A}$<br>$T_J = 150\text{ °C}$<br>See <a href="#">Figure 17</a> | P_6.6.2  |
| <b>Overvoltage</b>                                 |                    |        |                   |                   |      |   |          |
| Overvoltage protection                             | $V_{S(AZ)}$        | 66     | 70                | 75                | V    | $I_{SOV} = 5\text{ mA}$<br>See <a href="#">Figure 16</a>                      | P_6.6.3  |
| <b>Overload Condition</b>                          |                    |        |                   |                   |      |   |          |
| Load current limitation                            | $I_{L5(SC)}$       | 68     | 86                | 104               | A    | <sup>3)</sup> $V_{DS} = 7\text{ V}$<br>See <a href="#">Chapter 9</a>          | P_6.6.4  |
| Load current limitation                            | $I_{L28(SC)}$      | –      | 41                | –                 | A    | <sup>2)</sup> $V_{DS} = 42\text{ V}$<br>See <a href="#">Figure</a>            | P_6.6.7  |
| Dynamic temperature increase while switching       | $\Delta T_{J(SW)}$ | –      | 80                | –                 | K    | <sup>4)</sup> See <a href="#">Figure 19</a>                                   | P_6.6.8  |
| Thermal shutdown temperature                       | $T_{J(SC)}$        | 150    | 170 <sup>4)</sup> | 200 <sup>4)</sup> | °C   | <sup>5)</sup> See <a href="#">Figure 19</a>                                   | P_6.6.10 |
| Thermal shutdown hysteresis                        | $\Delta T_{J(SC)}$ | –      | 30                | –                 | K    | <sup>5) 4)</sup> See <a href="#">Figure 19</a>                                | P_6.6.11 |

 1) All pins are disconnected except  $V_S$  and OUT.

2) Not Subject to production test, specified by design

 3) Test at  $T_J = -40\text{ °C}$  only

4) Functional test only

 5) Test at  $T_J = +150\text{ °C}$  only