



Chipsmall Limited consists of a professional team with an average of over 10 year of expertise in the distribution of electronic components. Based in Hongkong, we have already established firm and mutual-benefit business relationships with customers from,Europe,America and south Asia,supplying obsolete and hard-to-find components to meet their specific needs.

With the principle of “Quality Parts,Customers Priority,Honest Operation,and Considerate Service”,our business mainly focus on the distribution of electronic components. Line cards we deal with include Microchip,ALPS,ROHM,Xilinx,Pulse,ON,Everlight and Freescale. Main products comprise IC,Modules,Potentiometer,IC Socket,Relay,Connector.Our parts cover such applications as commercial,industrial, and automotives areas.

We are looking forward to setting up business relationship with you and hope to provide you with the best service and solution. Let us make a better world for our industry!



Contact us

Tel: +86-755-8981 8866 Fax: +86-755-8427 6832

Email & Skype: info@chipsmall.com Web: www.chipsmall.com

Address: A1208, Overseas Decoration Building, #122 Zhenhua RD., Futian, Shenzhen, China



BU-23173-000
SHT 1.1

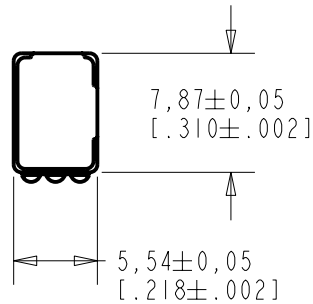

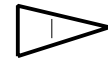
NOTE:
 LOCATED FROM TWO SURFACES FOR CUSTOMER CONVENIENCE. ONLY APPLICABLE FROM ONE SURFACE, NOT TO BE USED TOGETHER. HORIZONTAL LOCATION FOR TERMINAL CENTERED TO $\pm 0,17$ [0.007].

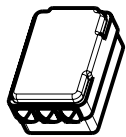
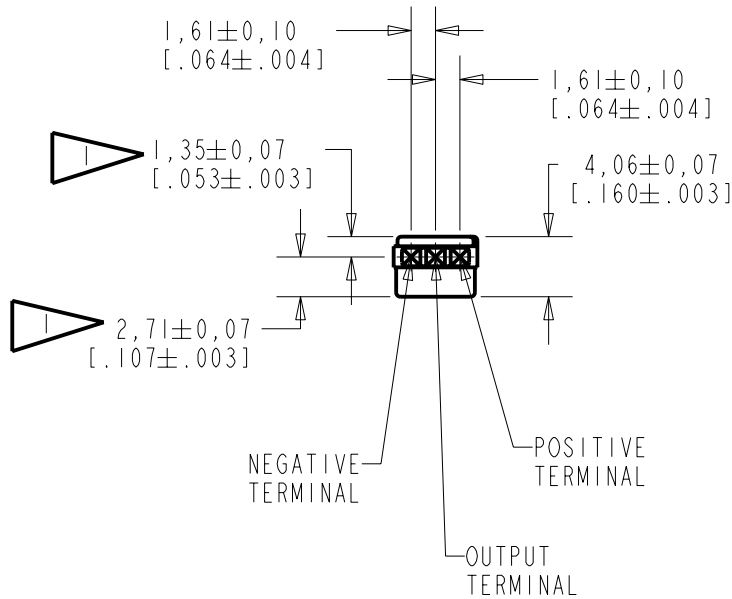

NOMINAL WEIGHT
.28 GRAM

DIMENSIONS IN MILLIMETERS [INCHES]

Revision	C.O. #	Implementation Date	RELEASE LEVEL	REVISION
B	MI0101515	7-16-07	Released	B
A	MI0101175	9-20-06		

SCALE: 2:1		DR. BY	DATE
DO NOT SCALE DRAWING		AB	9-20-06
TITLE: VIBRATION TRANSDUCER		CK. BY	DATE
OUTLINE DRAWING		GJP	9-25-06
BU-23173-000		APP. BY	DATE
SHT 1.1		GJP	9-25-06

KNOWLES ELECTRONICS
ITASCA, ILLINOIS U.S.A.

SENSITIVITY IN dB RELATIVE TO 1.0 VOLT/g
FOR CONDITIONS SHOWN BELOW

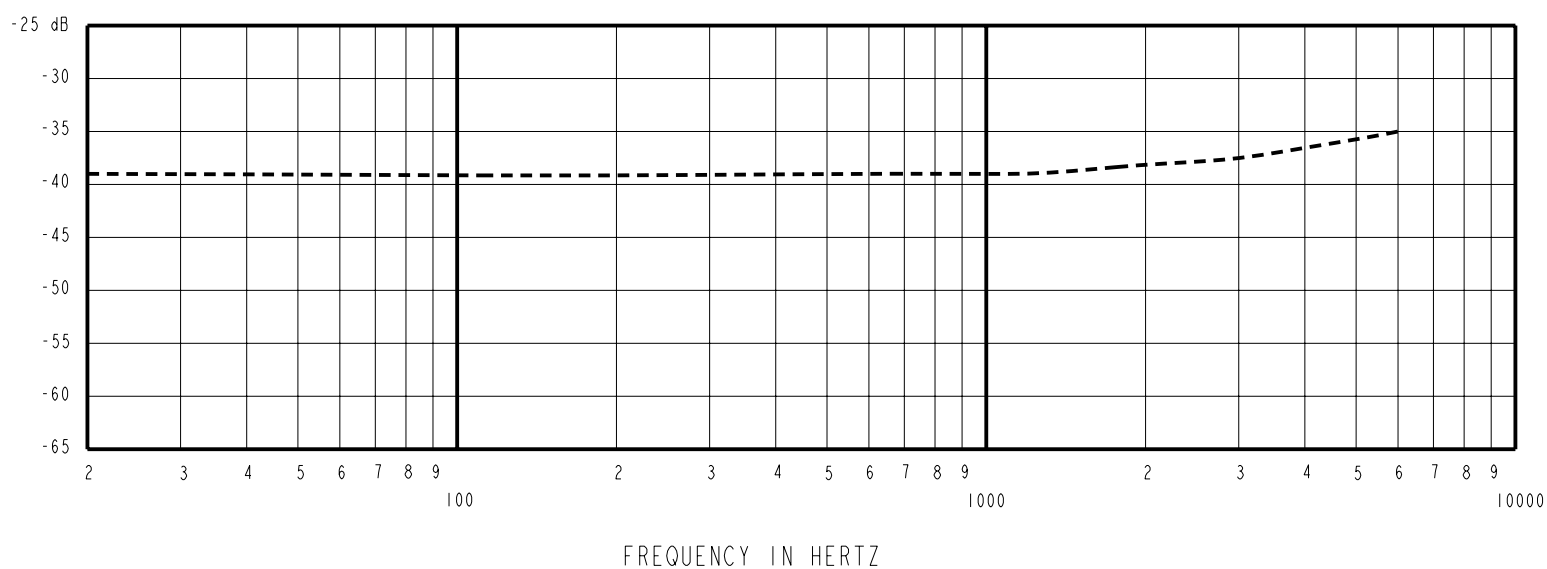

FREQUENCY	SENSITIVITY			DEVICE CONFORMITY	
	MIN.	NOM.	MAX.	RANGE OF DEVIATION FROM 1 kHz	
300	---	-39.0	---	-1.5	+1.5
1000	-43.5	-39.0	-34.5	0	0
3000	---	-37.5	---	-1.0	+2.0

NOTES:

1. ALL DATA MEASURED WITH CIRCUIT CONFIGURATION SHOWN BELOW.
2. CASE CONNECTED TO NEGATIVE TERMINAL.

DC SUPPLY	BATTERY CURRENT DRAIN	"A" WEIGHTED NOISE (RE 1.0V)	OUTPUT IMPEDANCE OHMS (AT 1 kHz)		
			MIN.	NOM.	MAX.
1.5 V	50 μ A MAX.	-103 dB MAX.	4900	5200	5500

3. TEST CONDITIONS:

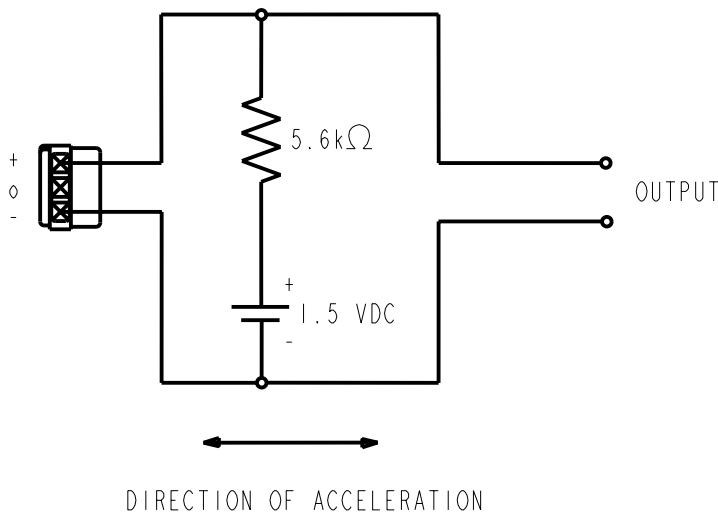

Revision	C.O. #	Implementation Date	RELEASE LEVEL	REVISION
B	M10101515	7-16-07	Released	B
A	M10101175	9-20-06		

KNOWLES ELECTRONICS
ITASCA, ILLINOIS U.S.A.

WHEN TEST LIMITS ARE USED TO ESTABLISH INCOMING INSPECTION ACCEPTANCE/REJECTION CRITERIA, CORRELATION OF TEST EQUIPMENT WITH KNOWLES IS ALSO REQUIRED FOR ELIMINATION OF EQUIPMENT AND TEST METHOD VARIATION

TITLE: **VIBRATION TRANSDUCER** **BU-23173-000**
PERFORMANCE SPECIFICATION **SHT 2.1**

DR. BY	DATE
AB	9-20-06
CK. BY	DATE
GJP	9-25-06
APP. BY	DATE
GJP	9-25-06