



Chipsmall Limited consists of a professional team with an average of over 10 year of expertise in the distribution of electronic components. Based in Hongkong, we have already established firm and mutual-benefit business relationships with customers from,Europe,America and south Asia,supplying obsolete and hard-to-find components to meet their specific needs.

With the principle of "Quality Parts,Customers Priority,Honest Operation,and Considerate Service",our business mainly focus on the distribution of electronic components. Line cards we deal with include Microchip,ALPS,ROHM,Xilinx,Pulse,ON,Everlight and Freescale. Main products comprise IC,Modules,Potentiometer,IC Socket,Relay,Connector.Our parts cover such applications as commercial,industrial, and automotives areas.

We are looking forward to setting up business relationship with you and hope to provide you with the best service and solution. Let us make a better world for our industry!



Contact us

Tel: +86-755-8981 8866 Fax: +86-755-8427 6832

Email & Skype: info@chipsmall.com Web: www.chipsmall.com

Address: A1208, Overseas Decoration Building, #122 Zhenhua RD., Futian, Shenzhen, China



Capacitive Controller ICs

Capacitive Switch Controller ICs

BU21072MUV / BU21078MUV / BU21078FV

General Description

BU21072MUV/BU21078MUV/BU21078FV is a capacitive sensor controller for switch operation. In addition to a regular simple switch, support matrix switches which are arranged in the matrix sensors. If external noise and temperature drift are detected, the automatic self-calibration is operated. Include LED controller with PWM function.

Features

- 10 capacitive sensor ports. (BU21072MUV)
12 capacitive sensor ports. (BU21078MUV / BU21078FV)
- Supported Matrix switches.
Maximum 16 switches. (BU21072MUV)
Maximum 36 switches. (BU21078MUV / BU21078FV)
- Automatic self-calibration.
- Continued touch detection.
- LED controller with PWM function.
- Inform the detected result of switch operation by interrupt.
- 2-wire serial bus interface.
- Single power supply.
- Built-in Power-On-Reset and Oscillator.

Applications

- Appliance that require multiple switches.
- Information appliance as printer.
- AV appliance as digital TV and HDD recorder.
- Notebook PC.

Typical Application Circuit

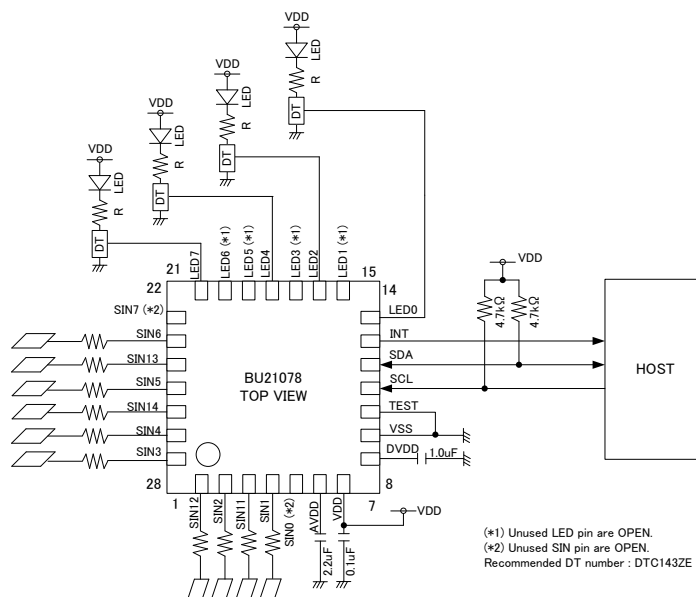

Figure 1. Typical Application Circuit

Key Specifications

- Input voltage range 3.0 to 5.5V
- Operating temperature range -20 to 85°C
- Operating current 3.5mA (Typ.)

- Scan rate 16msec (Typ.)

Packages

BU21072MUV :	VQFN024V4040	4.00 mm×4.00 mm×1.00 mm
BU21078MUV :	VQFN028V5050	5.00 mm×5.00 mm×1.00 mm
BU21078FV :	SSOP-B28	10.00 mm×7.60 mm×1.35 mm



VQFN024V4040

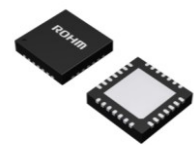

VQFN028V5050



SSOP-B28

OVERVIEW

BU21072MUV/BU21078MUV/BU21078FV is a capacitive sensor controller for switch operation. Included blocks are AFE (Analog Front End) detecting capacitance, A/D converter, MPU, LED ports with PWM function, 2-wire serial bus interface compatible with I2C protocol, power-on-reset, oscillator. Operate with a 3.0 to 5.5V single power supply.

The results that detected switch operations (Touch/Release/Hold) are held to each register. An interrupt is send from INT port to the host when a register is updated by detected operations. If external noise and temperature drift are detected, run automatic self-calibration. Without periodic polling, offer the reduction of the host load.

LED ports are able to be applied PWM function. PWM function offers fade-in / fade-out brightness control.

Simple switch

One sensor is assigned to one switch. Each simple switch has the registers of detected Touch/Release/Hold operations. Simple switches support to multi-detect Touch/Release/Hold. Unused simple switches are maskable.

Matrix switches

The cross points of the sensors which are arranged in a matrix are able to assigned to individual switches. Each matrix switch has the registers of detected Touch/Release/Hold operations. Matrix switches do not support to multi-detect Touch/Release/Hold. Not used matrix switches are maskable. BU21072MUV supports 16 matrix switches configured by 4x4 sensors, and BU21078MUV / BU21078FV supports 36 matrix switches configured by 6x6 sensors.

Automatic self-calibration

BU21072MUV/BU21078MUV/BU21078FV has observed the situation surrounding the sensor based on the detection result. If external noise and temperature drift are detected, the automatic self-calibration is operated for the stable detection result.

LED controller with PWM timers

LED controller is High active. Each LED port is assigned to a choice of four PWM timers. If the situation surrounding the sensor is changed by the switching LED, it is useable that calibration is operated by sending LED control command.

Host interface

BU21072MUV/BU21078MUV/BU21078FV is slave device for the host device. 2-wire serial bus is compatible with I2C protocol.

Slave Address : 0x5C(BU21072MUV) , 0x5D(BU21078MUV / BU21078FV)

Pin Configurations

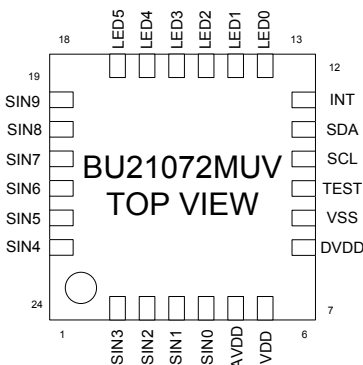

Figure 2. Pin configuration (BU21072MUV)

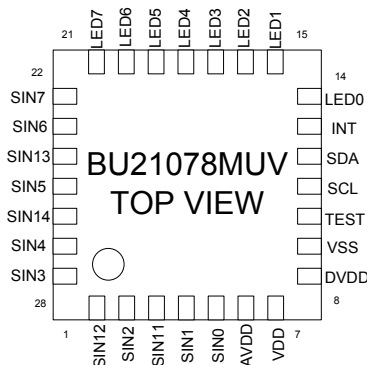

Figure 3. Pin configuration (BU21078MUV)

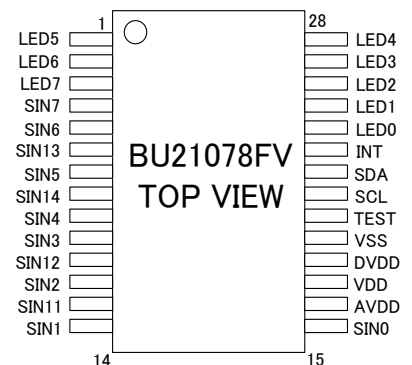

Figure 4. Pin configuration (BU21078FV)

Pin Descriptions

Number			Name	Type	Function	Note	Power	Initial Condition	I/O Equivalence Circuits
BU21072MUV	BU21078MUV	BU21078FV							
-	1	11	SIN12	Ain	Capacitive Touch Sensor12		AVDD	Hi-Z	Fig.5
2	2	12	SIN2	Ain	Capacitive Touch Sensor2		AVDD	Hi-Z	Fig.5
-	3	13	SIN11	Ain	Capacitive Touch Sensor11		AVDD	Hi-Z	Fig.5
3	4	14	SIN1	Ain	Capacitive Touch Sensor1		AVDD	Hi-Z	Fig.5
4	5	15	SIN0	Ain	Capacitive Touch Sensor0		AVDD	Hi-Z	Fig.5
5	6	16	AVDD	Power	LDO output for analog blocks		VDD	-	-
6	7	17	VDD	Power	Power		-	-	-
7	8	18	DVDD	Power	LDO output for digital blocks		VDD	-	-
8	9	19	VSS	GND	Ground		-	-	-
9	10	20	TEST	In	Test input	Please connect to Ground level	VDD	-	Fig.6
10	11	21	SCL	InOut	Host I/F clock input		VDD	Hi-Z	Fig.6
11	12	22	SDA	InOut	Bi-directional Host I/F Data		VDD	Hi-Z	Fig.6
12	13	23	INT	Out	Interrupt output	Active High Interrupt	VDD	"L"	Fig.7
13	14	24	LED0	Out	LED control with PWM output0	Active High	VDD	Hi-Z	Fig.7
14	15	25	LED1	Out	LED control with PWM output1	Active High	VDD	Hi-Z	Fig.7
15	16	26	LED2	Out	LED control with PWM output2	Active High	VDD	Hi-Z	Fig.7
16	17	27	LED3	Out	LED control with PWM output3	Active High	VDD	Hi-Z	Fig.7
17	18	28	LED4	Out	LED control with PWM output4	Active High	VDD	Hi-Z	Fig.7
18	19	1	LED5	Out	LED control with PWM output5	Active High	VDD	Hi-Z	Fig.7
-	20	2	LED6	Out	LED control with PWM output6	Active High	VDD	"L"	Fig.7
-	21	3	LED7	Out	LED control with PWM output7	Active High	VDD	"L"	Fig.7
19	-	-	SIN9	Ain	Capacitive Touch Sensor9		AVDD	Hi-Z	Fig.5
20	-	-	SIN8	Ain	Capacitive Touch Sensor8		AVDD	Hi-Z	Fig.5
21	22	4	SIN7	Ain	Capacitive Touch Sensor7		AVDD	Hi-Z	Fig.5
22	23	5	SIN6	Ain	Capacitive Touch Sensor6		AVDD	Hi-Z	Fig.5
-	24	6	SIN13	Ain	Capacitive Touch Sensor13		AVDD	Hi-Z	Fig.5
23	25	7	SIN5	Ain	Capacitive Touch Sensor5		AVDD	Hi-Z	Fig.5
-	26	8	SIN14	Ain	Capacitive Touch Sensor14		AVDD	Hi-Z	Fig.5
24	27	9	SIN4	Ain	Capacitive Touch Sensor4		AVDD	Hi-Z	Fig.5
1	28	10	SIN3	Ain	Capacitive Touch Sensor3		AVDD	Hi-Z	Fig.5

Initial Condition is at that power-on-reset is active.

I/O Equivalence Circuits

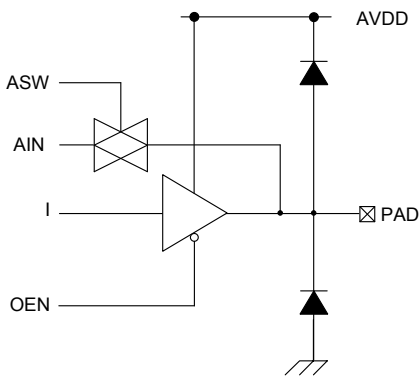

Figure 5. I/O equivalence circuit (a)

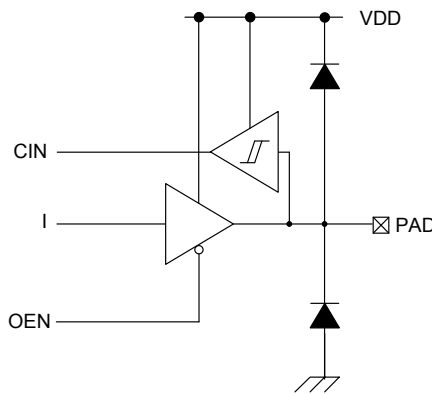

Figure 6. I/O equivalence circuit (b)

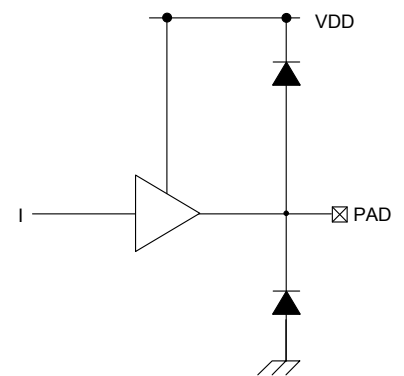

Figure 7. I/O equivalence circuit (c)

Block Diagram

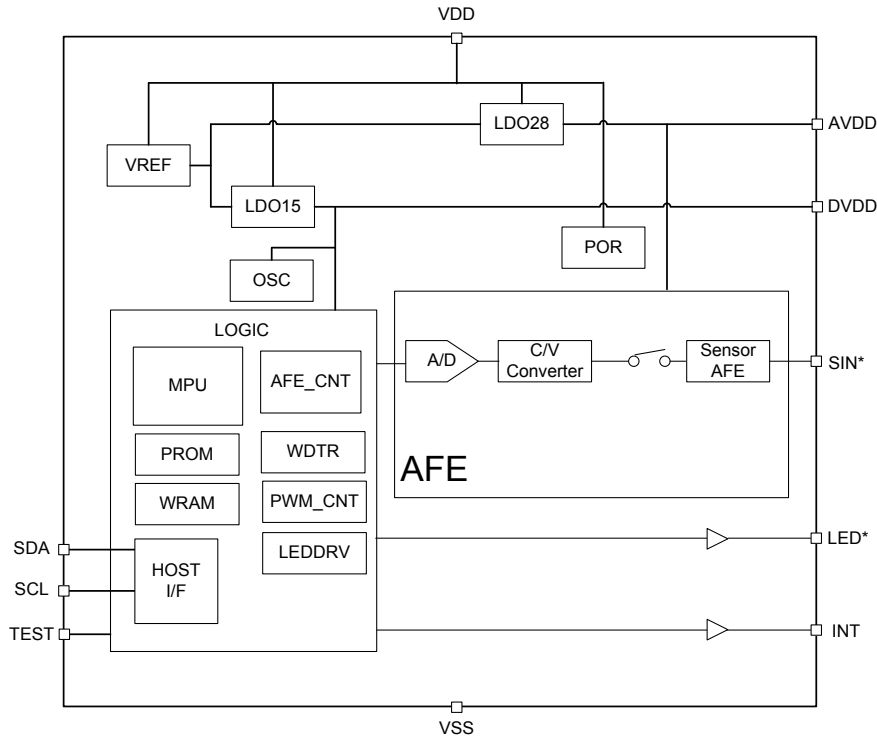

Figure 8. Block Diagram

Description of Blocks

Sensor AFE, C/V Converter

Convert from capacitance to voltage following the order of sensors.

A/D

Convert from voltage to the detected result the digital value.

LDO28

2.73V output LDO for Sensor AFE, C/V Converter and A/D.

LDO15

1.5V output LDO for OSC and digital blocks.

OSC

Ring oscillator as the system clock.

POR

Power-On-Reset monitoring VDD as the system reset.

MPU

Based on the detection result, detect switch operations (Touch/Release/Hold) and run Auto-calibration.

Inform by the INT port to the host about that the switch operations are detected.

LED ports are controlled by the commands from the host.

PROM

Program ROM for the included MPU.

WRAM

Work RAM for the included MPU.

HOST I/F

2-wire serial bus interface compatible with I2C protocol.

AFE_CNT

Sequencer of Sensor AFE, C/V converter and A/D.

PWM_CNT

PWM timers for the LED ports.

LEDDR

LED port drivers.

WDTR

Watchdog Timer Reset. It releases the system reset after 1 sec from that MPU cannot clear WDTR.

(If MPU cannot clear WDTR, MPU is hang-up.)

Absolute Maximum Ratings (Ta = 25°C)

Parameter		Symbol	Rating	Unit
Power supply voltage		VDD	-0.5 to 7.0	V
Input voltage		V _{IN}	-0.5 to VDD + 0.3	V
Storage temperature range		T _{stg}	-55 to 125	°C
Power dissipation	BU21072MUV	P _d	272 ^{*1}	mW
	BU21078MUV		304 ^{*2}	
	BU21078FV		640 ^{*3}	
Maximum junction temperature		T _{Jmax}	125	°C

*1 Derated by 2.72mW/°C over 25°C. (IC only).

*2 Derated by 3.04mW/°C over 25°C. (IC only).

*3 Derated by 6.4mW/°C over 25°C. (IC only).

Recommended Operating Ratings

Parameter		Symbol	Rating	Unit
Power supply voltage		VDD	3.0 to 5.5	V
Operating temperature range		T _{opr}	-20 to 85	°C

Electrical Characteristics (Ta = 25°C , VDD = 3.3V , VSS = 0V)

Parameter	Symbol	Rating			Unit	Condition
		Min.	Typ.	Max.		
Input High voltage	V _{IH}	VDD x 0.7	-	VDD + 0.3	V	
Input Low voltage	V _{IL}	VSS - 0.3	-	VDD x 0.3	V	
Output High voltage	V _{OH}	VDD - 0.5	-	VDD	V	I _{OH} = -4mA
Output Low voltage	V _{OL}	VSS	-	VSS + 0.5	V	I _{OL} = 4mA
Oscillator clock frequency	f _{OSC}	45	50	55	MHz	
DVDD LDO output voltage	V _{DVDD}	1.35	1.50	1.65	V	
AVDD LDO output voltage	V _{AVDD}	2.63	2.73	2.83	V	
Power-on-reset release voltage		2.25	-	2.55	V	
Power-on-reset detect voltage		2.10	-	2.40	V	
Operating current	I _{DD}	-	3.5	-	mA	Without load of sensors.

Register Map (OSC = 50MHz , unless otherwise noted)
 No accessing to the reserved areas is allowed.

Group	Address	Name	R/W	Ini	7	6	5	4	3	2	1	0	
Detect value	0x00	SIN_DATA	R	0x00	SD_SIN0 [7]	SD_SIN0 [6]	SD_SIN0 [5]	SD_SIN0 [4]	SD_SIN0 [3]	SD_SIN0 [2]	SD_SIN0 [1]	SD_SIN0 [0]	
	0x01	SIN_DATA	R	0x00	SD_SIN1 [7]	SD_SIN1 [6]	SD_SIN1 [5]	SD_SIN1 [4]	SD_SIN1 [3]	SD_SIN1 [2]	SD_SIN1 [1]	SD_SIN1 [0]	
	0x02	SIN_DATA	R	0x00	SD_SIN2 [7]	SD_SIN2 [6]	SD_SIN2 [5]	SD_SIN2 [4]	SD_SIN2 [3]	SD_SIN2 [2]	SD_SIN2 [1]	SD_SIN2 [0]	
	0x03	SIN_DATA	R	0x00	SD_SIN3 [7]	SD_SIN3 [6]	SD_SIN3 [5]	SD_SIN3 [4]	SD_SIN3 [3]	SD_SIN3 [2]	SD_SIN3 [1]	SD_SIN3 [0]	
	0x04	SIN_DATA	R	0x00	SD_SIN4 [7]	SD_SIN4 [6]	SD_SIN4 [5]	SD_SIN4 [4]	SD_SIN4 [3]	SD_SIN4 [2]	SD_SIN4 [1]	SD_SIN4 [0]	
	0x05	SIN_DATA	R	0x00	SD_SIN5 [7]	SD_SIN5 [6]	SD_SIN5 [5]	SD_SIN5 [4]	SD_SIN5 [3]	SD_SIN5 [2]	SD_SIN5 [1]	SD_SIN5 [0]	
	0x06	SIN_DATA	R	0x00	SD_SIN6 [7]	SD_SIN6 [6]	SD_SIN6 [5]	SD_SIN6 [4]	SD_SIN6 [3]	SD_SIN6 [2]	SD_SIN6 [1]	SD_SIN6 [0]	
	0x07	SIN_DATA	R	0x00	SD_SIN7 [7]	SD_SIN7 [6]	SD_SIN7 [5]	SD_SIN7 [4]	SD_SIN7 [3]	SD_SIN7 [2]	SD_SIN7 [1]	SD_SIN7 [0]	
	0x08	SIN_DATA	R	0x00	SD_SIN8 [7]	SD_SIN8 [6]	SD_SIN8 [5]	SD_SIN8 [4]	SD_SIN8 [3]	SD_SIN8 [2]	SD_SIN8 [1]	SD_SIN8 [0]	
	0x09	SIN_DATA	R	0x00	SD_SIN9 [7]	SD_SIN9 [6]	SD_SIN9 [5]	SD_SIN9 [4]	SD_SIN9 [3]	SD_SIN9 [2]	SD_SIN9 [1]	SD_SIN9 [0]	
	0x0A	SIN_DATA	R	0x00	SD_SIN10 [7]	SD_SIN10 [6]	SD_SIN10 [5]	SD_SIN10 [4]	SD_SIN10 [3]	SD_SIN10 [2]	SD_SIN10 [1]	SD_SIN10 [0]	
	0x0B	SIN_DATA	R	0x00	SD_SIN11 [7]	SD_SIN11 [6]	SD_SIN11 [5]	SD_SIN11 [4]	SD_SIN11 [3]	SD_SIN11 [2]	SD_SIN11 [1]	SD_SIN11 [0]	
	0x0C	SIN_DATA	R	0x00	SD_SIN12 [7]	SD_SIN12 [6]	SD_SIN12 [5]	SD_SIN12 [4]	SD_SIN12 [3]	SD_SIN12 [2]	SD_SIN12 [1]	SD_SIN12 [0]	
	0x0D	SIN_DATA	R	0x00	SD_SIN13 [7]	SD_SIN13 [6]	SD_SIN13 [5]	SD_SIN13 [4]	SD_SIN13 [3]	SD_SIN13 [2]	SD_SIN13 [1]	SD_SIN13 [0]	
	0x0E	SIN_DATA	R	0x00	SD_SIN14 [7]	SD_SIN14 [6]	SD_SIN14 [5]	SD_SIN14 [4]	SD_SIN14 [3]	SD_SIN14 [2]	SD_SIN14 [1]	SD_SIN14 [0]	
	0x0F	SIN_DATA	R	0x00	SD_SIN15 [7]	SD_SIN15 [6]	SD_SIN15 [5]	SD_SIN15 [4]	SD_SIN15 [3]	SD_SIN15 [2]	SD_SIN15 [1]	SD_SIN15 [0]	
Detect result	0x10	INTERRUPT	R	0x00	CONDET	OFFDET	ONDET	PERCAL	PWM	ERCAL	CAL	INI	
	0x11	STATE_SIN	R	0x00	SIN7	SIN6	SIN5	SIN4	SIN3	SIN2	SIN1	SIN0	
	0x12	STATE_SIN	R	0x00	SIN15	SIN14	SIN13	SIN12	SIN11	SIN10	SIN9	SIN8	
	0x13	DETECT_ON	R	0x00	SW7	SW6	SW5	SW4	SW3	SW2	SW1	SW0	
	0x14	DETECT_ON	R	0x00	SW15	SW14	SW13	SW12	SW11	SW10	SW9	SW8	
	0x15	DETECT_ON	R	0x00	MAT	-	KEY [5]	KEY [4]	KEY [3]	KEY [2]	KEY [1]	KEY [0]	
	0x16	DETECT_OFF	R	0x00	SW7	SW6	SW5	SW4	SW3	SW2	SW1	SW0	
	0x17	DETECT_OFF	R	0x00	SW15	SW14	SW13	SW12	SW11	SW10	SW9	SW8	
	0x18	DETECT_OFF	R	0x00	MAT	-	KEY [5]	KEY [4]	KEY [3]	KEY [2]	KEY [1]	KEY [0]	
	0x19	DETECT_CONT	R	0x00	SW7	SW6	SW5	SW4	SW3	SW2	SW1	SW0	
	0x1A	DETECT_CONT	R	0x00	SW15	SW14	SW13	SW12	SW11	SW10	SW9	SW8	
	0x1B	DETECT_CONT	R	0x00	MAT	-	KEY [5]	KEY [4]	KEY [3]	KEY [2]	KEY [1]	KEY [0]	
	0x1C	STATE	R	0x00	-	-	-	-	-	-	-	CALIB	
	0x1D	DETECT_PWM_FINISH	R	0x00	LED7	LED6	LED5	LED4	LED3	LED2	LED1	LED0	
	0x1E	RACT	R	0x00	RACT [7]	RACT [6]	RACT [5]	RACT [4]	RACT [3]	RACT [2]	RACT [1]	RACT [0]	
-	0x1F	Reserved											
-	0x20-84	Reserved											
-	0x85	SRST	R/W	0x00	SRST [7]	SRST [6]	SRST [5]	SRST [4]	SRST [3]	SRST [2]	SRST [1]	SRST [0]	
-	0x86-89	Reserved											
-	0x8A	SRST	R/W	0x00	SRST [15]	SRST [14]	SRST [13]	SRST [12]	SRST [11]	SRST [10]	SRST [9]	SRST [8]	
-	0x8B-BF	Reserved											
Sensor setting	0xC0	CFG_SIN	R/W	0x00	GA_SIN1 [1]	GA_SIN1 [0]	ON_SIN1 [1]	ON_SIN1 [0]	GA_SIN0 [1]	GA_SIN0 [0]	ON_SIN0 [1]	ON_SIN0 [0]	
	0xC1	CFG_SIN	R/W	0x00	GA_SIN3 [1]	GA_SIN3 [0]	ON_SIN3 [1]	ON_SIN3 [0]	GA_SIN2 [1]	GA_SIN2 [0]	ON_SIN2 [1]	ON_SIN2 [0]	
	0xC2	CFG_SIN	R/W	0x00	GA_SIN5 [1]	GA_SIN5 [0]	ON_SIN5 [1]	ON_SIN5 [0]	GA_SIN4 [1]	GA_SIN4 [0]	ON_SIN4 [1]	ON_SIN4 [0]	
	0xC3	CFG_SIN	R/W	0x00	GA_SIN7 [1]	GA_SIN7 [0]	ON_SIN7 [1]	ON_SIN7 [0]	GA_SIN6 [1]	GA_SIN6 [0]	ON_SIN6 [1]	ON_SIN6 [0]	
	0xC4	CFG_SIN	R/W	0x00	GA_SIN9 [1]	GA_SIN9 [0]	ON_SIN9 [1]	ON_SIN9 [0]	GA_SIN8 [1]	GA_SIN8 [0]	ON_SIN8 [1]	ON_SIN8 [0]	
	0xC5	CFG_SIN	R/W	0x00	GA_SIN11 [1]	GA_SIN11 [0]	ON_SIN11 [1]	ON_SIN11 [0]	GA_SIN10 [1]	GA_SIN10 [0]	ON_SIN10 [1]	ON_SIN10 [0]	
	0xC6	CFG_SIN	R/W	0x00	GA_SIN13 [1]	GA_SIN13 [0]	ON_SIN13 [1]	ON_SIN13 [0]	GA_SIN12 [1]	GA_SIN12 [0]	ON_SIN12 [1]	ON_SIN12 [0]	
	0xC7	CFG_SIN	R/W	0x00	GA_SIN15 [1]	GA_SIN15 [0]	ON_SIN15 [1]	ON_SIN15 [0]	GA_SIN14 [1]	GA_SIN14 [0]	ON_SIN14 [1]	ON_SIN14 [0]	
	0xC8	GA1 , GA0	R/W	0x00	GA1 [3]	GA1 [2]	GA1 [1]	GA1 [0]	GA0 [3]	GA0 [2]	GA0 [1]	GA0 [0]	
	0xC9	GA2	R/W	0x00	-	-	-	-	GA2 [3]	GA2 [2]	GA2 [1]	GA2 [0]	
	0xCA	ON0	R/W	0x00	ON0 [7]	ON0 [6]	ON0 [5]	ON0 [4]	ON0 [3]	ON0 [2]	ON0 [1]	ON0 [0]	
	0xCB	ON1	R/W	0x00	ON1 [7]	ON1 [6]	ON1 [5]	ON1 [4]	ON1 [3]	ON1 [2]	ON1 [1]	ON1 [0]	
	0xCC	ON2	R/W	0x00	ON2 [7]	ON2 [6]	ON2 [5]	ON2 [4]	ON2 [3]	ON2 [2]	ON2 [1]	ON2 [0]	
	0xCD	OFF	R/W	0x00	-	OFF [6]	OFF [5]	OFF [4]	OFF [3]	OFF [2]	OFF [1]	OFF [0]	
	0xCE	OSTIMES	R/W	0x00	OST [3]	OST [2]	OST [1]	OST [0]	-	-	-	-	
	0xCF	CONTIMES	R/W	0x00	CONSEL	-	CONT [5]	CONT [4]	CONT [3]	CONT [2]	CONT [1]	CONT [0]	
	Mask setting	0xD0	MSK_SW_KEY	R/W	0x00	MSK_SW7	MSK_SW6	MSK_SW5	MSK_SW4	MSK_SW3	MSK_SW2	MSK_SW1	MSK_SW0
0xD1		MSK_SW_KEY	R/W	0x00	MSK_SW15	MSK_SW14	MSK_SW13	MSK_SW12	MSK_SW11	MSK_SW10	MSK_SW9	MSK_SW8	
0xD2		MSK_SW_KEY	R/W	0x00	MSK_KEYH	MSK_KEYG	MSK_KEYF	MSK_KEYE	MSK_KEYD	MSK_KEYC	MSK_KEYB	MSK_KEYA	
0xD3		MSK_SW_KEY	R/W	0x00	MSK_KEYP	MSK_KEYO	MSK_KEYN	MSK_KEYM	MSK_KEYL	MSK_KEYK	MSK_KEYJ	MSK_KEYI	
0xD4		MSK_SW_KEY	R/W	0x00	MSK_KEYX	MSK_KEYW	MSK_KEYV	MSK_KEYU	MSK_KEYT	MSK_KEYS	MSK_KEYR	MSK_KEYQ	
0xD5		MSK_SW_KEY	R/W	0x00	MSK_KEYAF	MSK_KEYAE	MSK_KEYAD	MSK_KEYAC	MSK_KEYAB	MSK_KEYAA	MSK_KEYZ	MSK_KEYY	
0xD6		MSK_SW_KEY	R/W	0x00	-	-	-	-	MSK_KEYAJ	MSK_KEYAI	MSK_KEYAH	MSK_KEYAG	
0xD7-0xDE		Reserved											
0xDF	MSK_INTERRUPT	R/W	0x00	-	-	-	MSK_PERCAL	-	MSK_ERCAL	MSK_CAL	-		
PWM setting	0xE0	PWM-0	R/W	0x00	FAL [3]	FAL [2]	FAL [1]	FAL [0]	RIS [3]	RIS [2]	RIS [1]	RIS [0]	
	0xE1	PWM-0	R/W	0x00	OFF [3]	OFF [2]	OFF [1]	OFF [0]	ON [3]	ON [2]	ON [1]	ON [0]	
	0xE2	PWM-0	R/W	0x00	-	-	-	-	REP [3]	REP [2]	REP [1]	REP [0]	
	0xE3	PWM-1	R/W	0x00	FAL [3]	FAL [2]	FAL [1]	FAL [0]	RIS [3]	RIS [2]	RIS [1]	RIS [0]	
	0xE4	PWM-1	R/W	0x00	OFF [3]	OFF [2]	OFF [1]	OFF [0]	ON [3]	ON [2]	ON [1]	ON [0]	
	0xE5	PWM-1	R/W	0x00	-	-	-	-	REP [3]	REP [2]	REP [1]	REP [0]	
	0xE6	PWM-2	R/W	0x00	FAL [3]	FAL [2]	FAL [1]	FAL [0]	RIS [3]	RIS [2]	RIS [1]	RIS [0]	
	0xE7	PWM-2	R/W	0x00	OFF [3]	OFF [2]	OFF [1]	OFF [0]	ON [3]	ON [2]	ON [1]	ON [0]	
	0xE8	PWM-2	R/W	0x00	-	-	-	-	REP [3]	REP [2]	REP [1]	REP [0]	
	0xE9	PWM-3	R/W	0x00	FAL [3]	FAL [2]	FAL [1]	FAL [0]	RIS [3]	RIS [2]	RIS [1]	RIS [0]	
	0xEA	PWM-3	R/W	0x00	OFF [3]	OFF [2]	OFF [1]	OFF [0]	ON [3]	ON [2]	ON [1]	ON [0]	
	0xEB	PWM-3	R/W	0x00	-	-	-	-	REP [3]	REP [2]	REP [1]	REP [0]	
	0xEC	PWM_EN	R/W	0x00	LED7_EN	LED6_EN	LED5_EN	LED4_EN	LED3_EN	LED2_EN	LED1_EN	LED0_EN	
	0xED	PWM_ASSIGN	R/W	0x00	LED3_PA [1]	LED3_PA [0]	LED2_PA [1]	LED2_PA [0]	LED1_PA [1]	LED1_PA [0]	LED0_PA [1]	LED0_PA [0]	
	0xEE	PWM_ASSIGN	R/W	0x00	LED7_PA [1]	LED7_PA [0]	LED6_PA [1]	LED6_PA [0]	LED5_PA [1]	LED5_PA [0]	LED4_PA [1]	LED4_PA [0]	
0xEF	LED_CALIB	R/W	0x00	PERIOD [3]	PERIOD [2]	PERIOD [1]	PERIOD [0]	PWMCAL	PERIODCOND	PERCAL	LEDICAL		
Control	0xF0	CLR_INTERRUPT	R/W	0x00	-	-	-	PERCAL	-	ERCAL	CAL	INI	
	0xF1	CLR_DETECT_ON	R/W	0x00	SW7	SW6	SW5	SW4	SW3	SW2	SW1	SW0	
	0xF2	CLR_DETECT_ON	R/W	0x00	SW15	SW14	SW13	SW12	SW11	SW10	SW9	SW8	
	0xF3	CLR_DETECT_ON	R/W	0x00	MAT	-	-	-	-	-	-	-	
	0xF4	CLR_DETECT_OFF	R/W	0x00	SW7	SW6	SW5	SW4	SW3	SW2	SW1	SW0	
	0xF5	CLR_DETECT_OFF	R/W	0x00	SW15	SW14	SW13	SW12	SW11	SW10	SW9	SW8	
	0xF6	CLR_DETECT_OFF	R/W	0x00	MAT	-	-	-	-	-	-	-	
	0xF7	CLR_DETECT_CONT	R/W	0x00	SW7	SW6	SW5	SW4	SW3	SW2	SW1	SW0	
	0xF8	CLR_DETECT_CONT	R/W	0x00	SW15	SW14	SW13	SW12	SW11	SW10	SW9	SW8	
	0xF9	CLR_DETECT_CONT	R/W	0x00	MAT	-	-	-	-	-	-	-	
	0xFA	LED_CH	R/W	0x00	LED7	LED6	LED5	LED4	LED3	LED2	LED1	LED0	
	0xFB	CLR_DETECT_PWM_FINISH	R/W	0x00	LED7	LED6	LED5	LED4	LED3	LED2	LED1	LED0	
	0xFC-0xFD	Reserved											
	0xFE	WACT	R/W	0x00	WACT [7]	WACT [6]	WACT [5]	WACT [4]	WACT [3]	WACT [2]	WACT [1]	WACT [0]	
	0xFF	CNT	R/W	0x00	FRCRLS	CALOVF	-	CALMOD	-	CFG	CAL	ACT	

[0x00-0x0F : Sensor Data]

Name: SIN_DATA
 Address: 0x00-0x0F
 Description: This register shows 8bit ADC value of each sensor.

	Bit7	Bit6	Bit5	Bit4	Bit3	Bit2	Bit1	Bit0
0x00	SD_SIN0[7]	SD_SIN0[6]	SD_SIN0[5]	SD_SIN0[4]	SD_SIN0[3]	SD_SIN0[2]	SD_SIN0[1]	SD_SIN0[0]
0x01	SD_SIN1[7]	SD_SIN1[6]	SD_SIN1[5]	SD_SIN1[4]	SD_SIN1[3]	SD_SIN1[2]	SD_SIN1[1]	SD_SIN1[0]
0x02	SD_SIN2[7]	SD_SIN2[6]	SD_SIN2[5]	SD_SIN2[4]	SD_SIN2[3]	SD_SIN2[2]	SD_SIN2[1]	SD_SIN2[0]
0x03	SD_SIN3[7]	SD_SIN3[6]	SD_SIN3[5]	SD_SIN3[4]	SD_SIN3[3]	SD_SIN3[2]	SD_SIN3[1]	SD_SIN3[0]
0x04	SD_SIN4[7]	SD_SIN4[6]	SD_SIN4[5]	SD_SIN4[4]	SD_SIN4[3]	SD_SIN4[2]	SD_SIN4[1]	SD_SIN4[0]
0x05	SD_SIN5[7]	SD_SIN5[6]	SD_SIN5[5]	SD_SIN5[4]	SD_SIN5[3]	SD_SIN5[2]	SD_SIN5[1]	SD_SIN5[0]
0x06	SD_SIN6[7]	SD_SIN6[6]	SD_SIN6[5]	SD_SIN6[4]	SD_SIN6[3]	SD_SIN6[2]	SD_SIN6[1]	SD_SIN6[0]
0x07	SD_SIN7[7]	SD_SIN7[6]	SD_SIN7[5]	SD_SIN7[4]	SD_SIN7[3]	SD_SIN7[2]	SD_SIN7[1]	SD_SIN7[0]
0x08	SD_SIN8[7]	SD_SIN8[6]	SD_SIN8[5]	SD_SIN8[4]	SD_SIN8[3]	SD_SIN8[2]	SD_SIN8[1]	SD_SIN8[0]
0x09	SD_SIN9[7]	SD_SIN9[6]	SD_SIN9[5]	SD_SIN9[4]	SD_SIN9[3]	SD_SIN9[2]	SD_SIN9[1]	SD_SIN9[0]
0x0A	SD_SIN10[7]	SD_SIN10[6]	SD_SIN10[5]	SD_SIN10[4]	SD_SIN10[3]	SD_SIN10[2]	SD_SIN10[1]	SD_SIN10[0]
0x0B	SD_SIN11[7]	SD_SIN11[6]	SD_SIN11[5]	SD_SIN11[4]	SD_SIN11[3]	SD_SIN11[2]	SD_SIN11[1]	SD_SIN11[0]
0x0C	SD_SIN12[7]	SD_SIN12[6]	SD_SIN12[5]	SD_SIN12[4]	SD_SIN12[3]	SD_SIN12[2]	SD_SIN12[1]	SD_SIN12[0]
0x0D	SD_SIN13[7]	SD_SIN13[6]	SD_SIN13[5]	SD_SIN13[4]	SD_SIN13[3]	SD_SIN13[2]	SD_SIN13[1]	SD_SIN13[0]
0x0E	SD_SIN14[7]	SD_SIN14[6]	SD_SIN14[5]	SD_SIN14[4]	SD_SIN14[3]	SD_SIN14[2]	SD_SIN14[1]	SD_SIN14[0]
0x0F	SD_SIN15[7]	SD_SIN15[6]	SD_SIN15[5]	SD_SIN15[4]	SD_SIN15[3]	SD_SIN15[2]	SD_SIN15[1]	SD_SIN15[0]
R/W	R	R	R	R	R	R	R	R
Initial val.	0	0	0	0	0	0	0	0

[0x10 : Interrupt factor]

Name: INTERRUPT
 Address: 0x10
 Description: This register shows the interrupt factors. Port INT outputs this register's OR operation.

INI : Initialization finish.

This register is set to '1' when initialization is complete after power-on-sequence or watch dog timer reset. This register is cleared by setting '0' to the bit INI that is included the "Interrupt Source" registers (Address 0xF0).

CAL : Software-calibration finish.

This register is set to '1' when software calibration is complete. This register is cleared by setting '0' to the bit CAL that is included the "Clear interrupt" registers (Address 0xF0).

ERCAL :Error.

This register is set to '1' when IC should be executing the re-calibration. This register is cleared by setting '0' to the bit ERCAL that is included the "Clear interrupt" registers (Address 0xF0). IC executes self calibration after this interrupt.

PWM : PWM continuous flashing of LED finish.

This register is set to '1' when LED PWM drive has finished. This register is cleared by clearing every bit of the "Interrupt of PWM continuous flashing" register.

PERCAL : Periodic calibration finish.

This register is set to '1' when periodic calibration is complete. This register is cleared by setting '0' to the bit PERCAL that is included the "Clear interrupt" registers (Address 0xF0).

ONDET : Detection of switch-on.

This register is set to '1' when it detects a switch operation is considered to be Off. This register is cleared by clearing every bit of the "Detection Switch-On" register.

OFFDET : Detection of switch-off.

This register is set to '1' when it detects a switch operation is considered to be Off. This register is cleared by clearing every bit of the "Detection Switch-Off" register.

CONTDDET : Detection of continued touch.

This register is set to '1' when it detects a continued touch switch operation. This register is cleared by clearing every bit of the "Detection continued touch" register.

	Bit7	Bit6	Bit5	Bit4	Bit3	Bit2	Bit1	Bit0
0x10	CONTDDET	OFFDET	ONDET	PERCAL	PWM	ERCAL	CAL	INI
R/W	R	R	R	R	R	R	R	R
Initial val.	0	0	0	0	0	0	0	0

[0x11-0x12 : Sensor State]

Name: STATE_SIN
 Address: 0x11-0x12
 Description: This register indicates the status of switch-on or switch-off for each sensor.
 1 : Switch-on.(Register "SIN" > Register "ON") 0 : switch-off. (Register "SIN" < Register "OFF")

	Bit7	Bit6	Bit5	Bit4	Bit3	Bit2	Bit1	Bit0
0x11	SIN7	SIN6	SIN5	SIN4	SIN3	SIN2	SIN1	SIN0
0x12	SIN15	SIN14	SIN13	SIN12	SIN11	SIN10	SIN9	SIN8
R/W	R	R	R	R	R	R	R	R
Initial val.	0	0	0	0	0	0	0	0

[0x13-0x15 : Detection Switch-On]

Name: DETECT_ON
 Address: 0x13-0x15
 Description: This register indicates the change from Off to On every switch.
 Since SW 0-15 supports multiple pressed, each switch has a bit recognition. And the matrix key does not correspond to multiple press, so matrix switch is indicated by 1 bit for ON detection (MAT) and 6 bits for 36 positions (KEY). Logical OR of each SW and MAT will be ONDET interrupt source register.
 1 : Detect On. 0 :Cleared.

	Bit7	Bit6	Bit5	Bit4	Bit3	Bit2	Bit1	Bit0
0x13	SW7	SW6	SW5	SW4	SW3	SW2	SW1	SW0
0x14	SW15	SW14	SW13	SW12	SW11	SW10	SW9	SW8
0x15	MAT	-	KEY[5]	KEY[4]	KEY[3]	KEY[2]	KEY[1]	KEY[0]
R/W	R	R	R	R	R	R	R	R
Initial val.	0	0	0	0	0	0	0	0

[0x16-0x18 : Detection Switch-Off]

Name: DETECT_OFF
 Address: 0x16-0x18
 Description: This register indicates the change from On to Off every switch.
 Since SW 0-15 supports multiple pressed, each switch has a bit recognition. And the matrix key does not correspond to multiple press, so matrix switch is indicated by 1 bit for OFF detection (MAT) and 6 bits for 36 positions (KEY). Logical OR of each SW and MAT will be OFFDET interrupt source register.
 1 : Detect Off. 0 :Cleared.

	Bit7	Bit6	Bit5	Bit4	Bit3	Bit2	Bit1	Bit0
0x16	SW7	SW6	SW5	SW4	SW3	SW2	SW1	SW0
0x17	SW15	SW14	SW13	SW12	SW11	SW10	SW9	SW8
0x18	MAT	-	KEY[5]	KEY[4]	KEY[3]	KEY[2]	KEY[1]	KEY[0]
R/W	R	R	R	R	R	R	R	R
Initial val.	0	0	0	0	0	0	0	0

[0x19-0x1B : Detection continued touch]

Name: DETECT_CONT
 Address: 0x19-0x1B
 Description: This register indicates the detection of continued touch every switch.
 Since SW 0-15 supports multiple pressed, each switch has a bit recognition. And the matrix key does not correspond to multiple press, so matrix switch is indicated by 1 bit for CONT detection (MAT) and 6 bits for 36 positions (KEY). Logical OR of each SW and MAT will be CONTDET interrupt source register.
 1 : Detect continued touch. 0 :Cleared.

	Bit7	Bit6	Bit5	Bit4	Bit3	Bit2	Bit1	Bit0
0x19	SW7	SW6	SW5	SW4	SW3	SW2	SW1	SW0
0x1A	SW15	SW14	SW13	SW12	SW11	SW10	SW9	SW8
0x1B	MAT	-	KEY[5]	KEY[4]	KEY[3]	KEY[2]	KEY[1]	KEY[0]
R/W	R	R	R	R	R	R	R	R
Initial val.	0	0	0	0	0	0	0	0

[0x1C : State of IC]

Name: STATE
 Address: 0x1C
 Description: This register indicates the state of IC.

CALIB : During calibration :
 This bit indicates that IC is during calibration. When this bit is "1", IC is doing calibration.
 The required time for calibration : About 150msec.

	Bit7	Bit6	Bit5	Bit4	Bit3	Bit2	Bit1	Bit0
0x1C	-	-	-	-	-	-	-	CALIB
R/W	-	-	-	-	-	-	-	R
Initial val.	-	-	-	-	-	-	-	0

[0x1D : Interrupt of PWM continuous flashing]

Name: DETECT_PWM_FINISH
 Address: 0x1D
 Description: This register indicates the end of the LED PWM drive. This register has a bit aware of each LED. The logical OR of all bits of this register will be the bit PWM that is included in the "Interrupt Source" registers.
 1 : Finished LED PWM drive. 0 : Clear.

	Bit7	Bit6	Bit5	Bit4	Bit3	Bit2	Bit1	Bit0
0x1D	LED7	LED6	LED5	LED4	LED3	LED2	LED1	LED0
R/W	R	R	R	R	R	R	R	R
Initial val.	0	0	0	0	0	0	0	0

[0x1E : Read register for operation check of CPU]

Name: RACT
 Address: 0x1E
 Description: This register is a read register for operational check of the IC. The value written to the write register for operation check (Address is 0xFE) is copied to this register. Comparing the write value with the read value is equal, CPU and I/F are operating normally.
 The required time to copy to this register from the write register for operation check : About 20usec.

	Bit7	Bit6	Bit5	Bit4	Bit3	Bit2	Bit1	Bit0
0x1E	RACT[7]	RACT[6]	RACT[5]	RACT[4]	RACT[3]	RACT[2]	RACT[1]	RACT[0]
R/W	R	R	R	R	R	R	R	R
Initial val.	0	0	0	0	0	0	0	0

[0x85 , 0x8A : Software Reset]

Name: SRST
 Address: 0x85, 0x8A
 Description: These registers make a hardware reset. When the value of "0x85" Register is set to 0x55 and the value of "0x8A" Register is set to 0xAA, a hardware reset will be generated.

	Bit7	Bit6	Bit5	Bit4	Bit3	Bit2	Bit1	Bit0
0x85	SRST[7]	SRST[6]	SRST[5]	SRST[4]	SRST[3]	SRST[2]	SRST[1]	SRST[0]
0x8A	SRST[15]	SRST[14]	SRST[13]	SRST[12]	SRST[11]	SRST[10]	SRST[9]	SRST[8]
R/W	R/W	R/W	R/W	R/W	R/W	R/W	R/W	R/W
Initial val.	0	0	0	0	0	0	0	0

[0xC0 – 0xC7 : Select a setting for Gain and Threshold for “Off→On”]

Name: CFG_SIN

Address: 0xC0 – 0xC7

Description: You can set 3 values for gain and set 3 values for threshold for “Off → On” to this IC.

These registers are used to select a setting for gain and threshold from three settings for every each sensor.

Gain : GA_SIN*[1:0] = 0x0 : Select GA0.
 0x1 : Select GA1.
 0x2 : Select GA2.
 0x3 : Select GA0.

Threshold : ON_SIN*[1:0] = 0x0 : Select ON0.
 0x1 : Select ON1.
 0x2 : Select ON2.
 0x3 : Select ON0.

	Bit7	Bit6	Bit5	Bit4	Bit3	Bit2	Bit1	Bit0
0xC0	GA_SIN1[1]	GA_SIN1[0]	ON_SIN1[1]	ON_SIN1[0]	GA_SIN0[1]	GA_SIN0[0]	ON_SIN0[1]	ON_SIN0[0]
0xC1	GA_SIN3[1]	GA_SIN3[0]	ON_SIN3[1]	ON_SIN3[0]	GA_SIN2[1]	GA_SIN2[0]	ON_SIN2[1]	ON_SIN2[0]
0xC2	GA_SIN5[1]	GA_SIN5[0]	ON_SIN5[1]	ON_SIN5[0]	GA_SIN4[1]	GA_SIN4[0]	ON_SIN4[1]	ON_SIN4[0]
0xC3	GA_SIN7[1]	GA_SIN7[0]	ON_SIN7[1]	ON_SIN7[0]	GA_SIN6[1]	GA_SIN6[0]	ON_SIN6[1]	ON_SIN6[0]
0xC4	GA_SIN9[1]	GA_SIN9[0]	ON_SIN9[1]	ON_SIN9[0]	GA_SIN8[1]	GA_SIN8[0]	ON_SIN8[1]	ON_SIN8[0]
0xC5	GA_SIN11[1]	GA_SIN11[0]	ON_SIN11[1]	ON_SIN11[0]	GA_SIN10[1]	GA_SIN10[0]	ON_SIN10[1]	ON_SIN10[0]
0xC6	GA_SIN13[1]	GA_SIN13[0]	ON_SIN13[1]	ON_SIN13[0]	GA_SIN12[1]	GA_SIN12[0]	ON_SIN12[1]	ON_SIN12[0]
0xC7	GA_SIN15[1]	GA_SIN15[0]	ON_SIN15[1]	ON_SIN15[0]	GA_SIN14[1]	GA_SIN14[0]	ON_SIN14[1]	ON_SIN14[0]
R/W	R/W	R/W	R/W	R/W	R/W	R/W	R/W	R/W
Initial val.	0	0	0	0	0	0	0	0

[0xC8 – 0xC9 : Value of GAIN]

Name: GA0, GA1, GA2

Address: 0xC8 – 0xC9

Description: This register is for setting the gain of AFE. The smaller the value of GA, the gain will be higher. You can set 3 values for gain. These value are assigned to each sensor by register GA_SIN included CFG_SIN.

The settable range : 0x1 ≤ GA ≤ 0xF

	Bit7	Bit6	Bit5	Bit4	Bit3	Bit2	Bit1	Bit0
0xC8	GA1[3]	GA1[2]	GA1[1]	GA1[0]	GA0[3]	GA0[2]	GA0[1]	GA0[0]
0xC9	-	-	-	-	GA2[3]	GA2[2]	GA2[1]	GA2[0]
R/W	R/W	R/W	R/W	R/W	R/W	R/W	R/W	R/W
Initial val.	0	0	0	0	0	0	0	0

[0xCA – 0xCC : Value of the threshold for "Off → On"]

Name: ON0, ON1, ON2

Address: 0xCA – 0xCC

Description: These registers are for setting the threshold for “Off → On” operation. You can set 3 values for threshold. If the 8bit ADC value of each sensor (register SENS_DATA) is larger than this value, the valid “Off → On” operation of the sensor is. These value are assigned to each sensor by register ON_SIN included CFG_SIN.

The settable range : 0x00 < OFF < ON < 0xFF

	Bit7	Bit6	Bit5	Bit4	Bit3	Bit2	Bit1	Bit0
0xCA	ON0[7]	ON0[6]	ON0[5]	ON0[4]	ON0[3]	ON0[2]	ON0[1]	ON0[0]
0xCB	ON1[7]	ON1[6]	ON1[5]	ON1[4]	ON1[3]	ON1[2]	ON1[1]	ON1[0]
0xCC	ON2[7]	ON2[6]	ON2[5]	ON2[4]	ON2[3]	ON2[2]	ON2[1]	ON2[0]
R/W	-	R/W	R/W	R/W	R/W	R/W	R/W	R/W
Initial val.	-	0	0	0	0	0	0	0

[0xCD : Value of the threshold for "On → Off"]

Name: OFF

Address: 0xCD

Description: This register is for setting the threshold for “On → Off” operation. If the 8bit ADC value of each sensor (register SENS_DATA) is smaller than this value, the valid “On → Off” operation of the sensor is.

The setting range : 0x00 < OFF < ON < 0xFF

	Bit7	Bit6	Bit5	Bit4	Bit3	Bit2	Bit1	Bit0
0xCD	-	OFF [6]	OFF [5]	OFF [4]	OFF [3]	OFF [2]	OFF [1]	OFF [0]
R/W	-	R/W	R/W	R/W	R/W	R/W	R/W	R/W
Initial val.	-	0	0	0	0	0	0	0

【0xCE : Configuration oversampling】

Name: OSTIMES

Address: 0xCE

Description: OST[3:0] : This register is the number of times of oversampling for canceling chattering to the "ON" or "OFF" operation. If the continuance of the "ON" or "OFF" operations is lower than this register, the operations are ignored.

If this register value is 0, the number of times of oversampling is 1.

Sampling rate : About 16[msec].

	Bit7	Bit6	Bit5	Bit4	Bit3	Bit2	Bit1	Bit0
0xCE	OST[3]	OST[2]	OST[1]	OST[0]	-	-	-	-
R/W	R/W	R/W	R/W	R/W	-	-	-	-
Initial val.	0	0	0	0	-	-	-	-

【0xCF : Configuration continuous touch】

Name: CONTTIMES

Address: 0xCF

Description: CONTSEL : This register is to select the interrupt frequency by detection continuous touch.

1 : Every continuous touch period.

0 : First detect only.

CONT[5:0] : Continuous touch period is about 0.1[sec] x CONT.

If the setting value is 0x0, continuous touch function is disable.

(0.1sec ≤ Continuous touch period ≤ 6.3sec)

	Bit7	Bit6	Bit5	Bit4	Bit3	Bit2	Bit1	Bit0
0xCF	CONTSEL	-	CONT[5]	CONT[4]	CONT[3]	CONT[2]	CONT[1]	CONT[0]
R/W	R/W	-	R/W	R/W	R/W	R/W	R/W	R/W
Initial val.	0	-	0	0	0	0	0	0

[0xD0 – 0xD6 : Mask switch operation]

Name: MSK_SW_KEY

Address: 0xD0 - 0xD6

Description: This register is for mask to the operation of each matrix switches and each simple switches. The masked switches are excluded from the interrupt factor. It is prohibited that one sensor is assigned to both a matrix switch and a simple switch. The unused switches must be masked. The switches configured by the not included sensors in IC (SIN10-15 in BU21072MUV, SIN8-10 and SIN15 in BU21078MUV/BU21078FV) must be masked.

1 : Masked. 0 : Unmasked.

	Bit7	Bit6	Bit5	Bit4	Bit3	Bit2	Bit1	Bit0
0xD0	MSK_SW7	MSK_SW6	MSK_SW5	MSK_SW4	MSK_SW3	MSK_SW2	MSK_SW1	MSK_SW0
0xD1	MSK_SW15	MSK_SW14	MSK_SW13	MSK_SW12	MSK_SW11	MSK_SW10	MSK_SW9	MSK_SW8
0xD2	MSK_KEYH	MSK_KEYG	MSK_KEYF	MSK_KEYE	MSK_KEYD	MSK_KEYC	MSK_KEYB	MSK_KEYA
0xD3	MSK_KEYP	MSK_KEYO	MSK_KEYN	MSK_KEYM	MSK_KEYL	MSK_KEYK	MSK_KEYJ	MSK_KEYI
0xD4	MSK_KEYX	MSK_KEYW	MSK_KEYV	MSK_KEYU	MSK_KEYT	MSK_KEYS	MSK_KEYR	MSK_KEYQ
0xD5	MSK_KEYAF	MSK_KEYAE	MSK_KEYAD	MSK_KEYAC	MSK_KEYAB	MSK_KEYAA	MSK_KEYZ	MSK_KEYYY
0xD6	-	-	-	-	MSK_KEYAJ	MSK_KEYAI	MSK_KEYAH	MSK_KEYAG
R/W	R/W	R/W	R/W	R/W	R/W	R/W	R/W	R/W
Initial val.	0	0	0	0	0	0	0	0

[0xDF : Mask interrupt]

Name: MSK_INTERRUPT

Address: 0xDF

Description: This register is for mask to the interrupt factor. The masked interrupt factor is not shown on the register "Interrupt factor (address 0x10)", so it does not affect to output port INT.

1 : Masked. 0 : Unmasked.

MSK_CAL : Mask for Software-calibration finish.

This bit does mask to the interrupt of Software-calibration finish (the bit CAL in the register INTERRUPT(address 0x10)).

MSK_ERCAL : Mask for Self-calibration finish.

This bit does mask to the interrupt of Self-calibration finish (the bit ERCAL in the register INTERRUPT(address 0x10)).

MSK_PERCAL : Mask for Periodic calibration finish.

This bit does mask to the interrupt of Periodic calibration finish (the bit PERCAL in the register INTERRUPT(address 0x10)).

	Bit7	Bit6	Bit5	Bit4	Bit3	Bit2	Bit1	Bit0
0xDF	-	-	-	MSK_PERCAL	-	MSK_ERCAL	MSK_CAL	-
R/W	-	-	-	R/W	-	R/W	R/W	-
Initial val.	-	-	-	0	-	0	0	-

[0xE0-0xEB : Configuration of PWM]

Name: PWM-0/1/2/3
 Address: 0xE0 – 0xEB

Description: Each of the 4 PWM timers (PWM-0/1/2/3) has 5 parameters. One PWM timer is able to be assigned to one LED port.

- ① RIS : Rising Period
 If the setting value is 0x0, PWM function is disabled.
 If the setting value is from 0x1 to 0xF, Rising Period is about 317[msec] x RIS.
 (317 ≤ Rising Period ≤ 4755 [msec])
 Update configuration timing :
 In rising period : Within 3msec.
 In other periods : Next rising period.
- ② FAL : Falling Period
 If the setting value is 0x0, PWM function is disabled.
 If the setting value is from 0x1 to 0xF, Falling Period is about 317[msec] x FAL.
 (317 ≤ Falling Period ≤ 4755 [msec])
 Update configuration timing :
 In falling period : Within 3msec.
 In other periods : Next falling period.
- ③ ON : Lighting-On Period
 If the setting value is 0x0, LED always lights.
 If the setting value is from 0x1 to 0xF, Light-On Period is about 300[msec] x ON.
 (300 ≤ Lighting-On Period ≤ 4500 [msec])
 In the case of that the LED always lights, the way to turn LED off is to write '0' to the LED port register. And the interrupt of PWM continuous flashing of LED finish is not issued. Falling period is applied.
 Update configuration timing :
 Next lighting-on period.
- ④ OFF : Lighting-Off Period
 The settable range : 0x0 ≤ OFF ≤ 0xF
 Light-Off Period is about 300[msec] x OFF.
 (0 ≤ Lighting-Off Period ≤ 4500 [msec])
 Update configuration timing :
 Next lighting-off period.
- ⑤ REP : Repeat Count
 If the setting value is 0x0, non repeat.
 If the setting value is 0xF, unlimited repeat.
 If the setting value is from 0x1 to 0xE, repeat as many times as the setting value.

When the PWM drive repeat as many times as the setting value, the register interrupt of PWM continuous flashing is set to '1' and I/O port INT is set to "H". Interrupts are cleared by writing '0' to the register clear interrupt of PWM continuous flashing (Address 0xFB).
 In the case that the setting is "unlimited repeat", interrupts are not released.

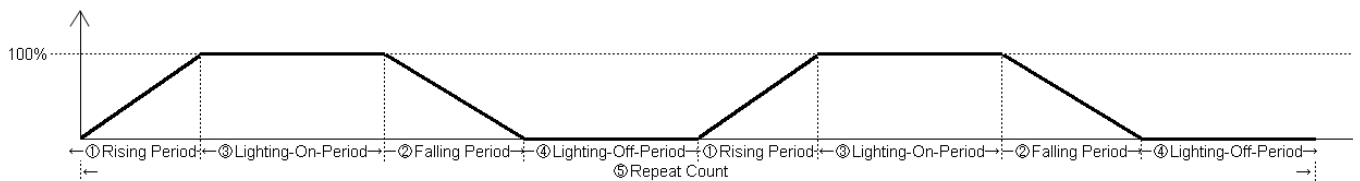

Figure 9. PWM waveform

PWM-0

	Bit7	Bit6	Bit5	Bit4	Bit3	Bit2	Bit1	Bit0
0xE0	FAL[3]	FAL[2]	FAL[1]	FAL[0]	RIS[3]	RIS[2]	RIS[1]	RIS[0]
0xE1	OFF[3]	OFF[2]	OFF[1]	OFF[0]	ON[3]	ON[2]	ON[1]	ON[0]
0xE2	-	-	-	-	REP[3]	REP[2]	REP[1]	REP[0]
R/W	R/W	R/W	R/W	R/W	R/W	R/W	R/W	R/W
Initial val.	0	0	0	0	0	0	0	0

PWM-1

	Bit7	Bit6	Bit5	Bit4	Bit3	Bit2	Bit1	Bit0
0xE3	FAL[3]	FAL[2]	FAL[1]	FAL[0]	RIS[3]	RIS[2]	RIS[1]	RIS[0]
0xE4	OFF[3]	OFF[2]	OFF[1]	OFF[0]	ON[3]	ON[2]	ON[1]	ON[0]
0xE5	-	-	-	-	REP[3]	REP[2]	REP[1]	REP[0]
R/W	R/W	R/W	R/W	R/W	R/W	R/W	R/W	R/W
Initial val.	0	0	0	0	0	0	0	0

PWM-2

	Bit7	Bit6	Bit5	Bit4	Bit3	Bit2	Bit1	Bit0
0xE6	FAL[3]	FAL[2]	FAL[1]	FAL[0]	RIS[3]	RIS[2]	RIS[1]	RIS[0]
0xE7	OFF[3]	OFF[2]	OFF[1]	OFF[0]	ON[3]	ON[2]	ON[1]	ON[0]
0xE8	-	-	-	-	REP[3]	REP[2]	REP[1]	REP[0]
R/W	R/W	R/W	R/W	R/W	R/W	R/W	R/W	R/W
Initial val.	0	0	0	0	0	0	0	0

PWM-3

	Bit7	Bit6	Bit5	Bit4	Bit3	Bit2	Bit1	Bit0
0xE9	FAL[3]	FAL[2]	FAL[1]	FAL[0]	RIS[3]	RIS[2]	RIS[1]	RIS[0]
0xEA	OFF[3]	OFF[2]	OFF[1]	OFF[0]	ON[3]	ON[2]	ON[1]	ON[0]
0xEB	-	-	-	-	REP[3]	REP[2]	REP[1]	REP[0]
R/W	R/W	R/W	R/W	R/W	R/W	R/W	R/W	R/W
Initial val.	0	0	0	0	0	0	0	0

[0xEC : Select PWM port]

Name: PWM_EN

Address: 0xEC

Description: This register is used to select whether to use PWM function for each LED port.
 1 : Use PWM function. 0 : Not use PWM function.

	Bit7	Bit6	Bit5	Bit4	Bit3	Bit2	Bit1	Bit0
0xEC	LED7_EN	LED6_EN	LED5_EN	LED4_EN	LED3_EN	LED2_EN	LED1_EN	LED0_EN
R/W	R/W	R/W	R/W	R/W	R/W	R/W	R/W	R/W
Initial val.	0	0	0	0	0	0	0	0

[0xED-0xEE : Select PWM setting]

Name: PWM_ASSIGN

Address: 0xED – 0xEE

Description: This register is used to set any PWM setting from the four settings to each LED port.
 0x0 : Assign PWM-0.
 0x1 : Assign PWM-1.
 0x2 : Assign PWM-2.
 0x3 : Assign PWM-3.

	Bit7	Bit6	Bit5	Bit4	Bit3	Bit2	Bit1	Bit0
0xED	LED3_PA[1]	LED3_PA[0]	LED2_PA[1]	LED2_PA[0]	LED1_PA[1]	LED1_PA[0]	LED0_PA[1]	LED0_PA[0]
0xEE	LED7_PA[1]	LED7_PA[0]	LED6_PA[1]	LED6_PA[0]	LED5_PA[1]	LED5_PA[0]	LED4_PA[1]	LED4_PA[0]
R/W	R/W	R/W	R/W	R/W	R/W	R/W	R/W	R/W
Initial val.	0	0	0	0	0	0	0	0

[0xEF : Configure calibration]

Name: LED_CALIB
 Address: 0xEF

Description: This register is used to select whether to perform the calibration. The calibration is done by access to any LED port or by periodic calibration.

LEDCAL : LED calibration :

This register is used to select whether to perform the self-calibration when any bit of the "LED drivers control (0xFA)" register is accessed.

1 : Not perform calibration. 0 : Perform calibration. (Default)

PERCAL : Periodical calibration :

This register is used to select whether to perform the periodic calibration.

1 : Not perform the periodic calibration. 0 : Perform the periodic calibration. (Default)

PERCALCOND : Condition of periodical calibration :

This register is used to select the condition to perform the periodic calibration.

1 : Always. 0 : At the setting to "1" to any bit of the "LED drivers control (0xFA)" register. (Default)

PWMCAL :

In the case that the periodic calibration is active (The "PERCAL" bit is "0"), this register is used to select whether to perform the periodic calibration when the LED port assigned to PWM function is set to active.

1 : Perform periodical calibration regardless of the condition of the LED port assigned to PWM function.

0 : Perform periodical calibration only the LED port assigned to PWM function is set to inactive. (default)

Condition	bit state		Periodical Calibration
	PERCAL	PWMCAL	
More than one LED port is active	0	0	Not Performed
		1	Performed
	1	0	Not Performed
		1	Performed
All LED port is inactive	0	0	Performed
		1	Not Performed
	1	0	Not Performed
		1	Performed

PERIOD[7:4] :

This register is used to set the interval of the periodic calibration.

The interval of the periodic calibration = About 5[sec] x (PERIOD + 1) (5sec ≤ The interval ≤ 80sec)

	Bit7	Bit6	Bit5	Bit4	Bit3	Bit2	Bit1	Bit0
0xEF	PERIOD[3]	PERIOD[2]	PERIOD[1]	PERIOD[0]	PWMCAL	PERCALCOND	PERCAL	LEDCAL
R/W	R/W	R/W	R/W	R/W	R/W	R/W	R/W	R/W
Initial val.	0	0	0	0	0	0	0	0

【0xF0 : Clear interrupt】

Name: CLR_INTERRUPT
Address: 0xF0

Description: Interrupt Clear Register
INI : Clear Interrupt of Initialization finish.
Clears the INI interrupt by writing '0' this register.
CAL : Clear Interrupt of Software-calibration finish.
Clears the CAL interrupt by writing '0' this register.
ERCAL : Clear Interrupt of Self-calibration finish.
Clears the ERCAL interrupt by writing '0' this register.
PERCAL : Clear Interrupt of Periodic calibration finish.
Clears the PERCAL interrupt by writing '0' this register.

	Bit7	Bit6	Bit5	Bit4	Bit3	Bit2	Bit1	Bit0
0xF0	-	-	-	PERCAL	-	ERCAL	CAL	INI
R/W	-	-	-	R/W	-	R/W	R/W	R/W
Initial val.	-	-	-	0	-	0	0	0

【0xF1-0xF3 : Clear Switch-ON】

Name: CLR_DETECT_ON
Address: 0xF1-0xF3

Description: DETECT_ON Clear Register. Clears the DETECT_ON by writing '0' these registers. If you write '1', the operation is invalid. SW 0-15 has each clear bit, cause SW 0-15 supports multiple pressed. The matrix key's DETECT_ON clear bit is 1bit for MAT, cause the matrix key does not correspond to multiple press.
1 : Invalid. 0 :Clear.

	Bit7	Bit6	Bit5	Bit4	Bit3	Bit2	Bit1	Bit0
0xF1	SW7	SW6	SW5	SW4	SW3	SW2	SW1	SW0
0xF2	SW15	SW14	SW13	SW12	SW11	SW10	SW9	SW8
0xF3	MAT	-	-	-	-	-	-	-
R/W	R/W	R/W	R/W	R/W	R/W	R/W	R/W	R/W
Initial val.	0	0	0	0	0	0	0	0

【0xF4-0xF6 : Clear Switch-OFF】

Name: CLR_DETECT_OFF
Address: 0xF4-0xF6

Description: DETECT_OFF Clear Register. Clears the DETECT_OFF by writing '0' these registers. If you write '1', the operation is invalid. SW 0-15 has each clear bit, cause SW 0-15 supports multiple pressed. The matrix key's DETECT_OFF clear bit is 1bit for MAT, cause the matrix key does not correspond to multiple press.
1 : Invalid. 0 :Clear.

	Bit7	Bit6	Bit5	Bit4	Bit3	Bit2	Bit1	Bit0
0xF4	SW7	SW6	SW5	SW4	SW3	SW2	SW1	SW0
0xF5	SW15	SW14	SW13	SW12	SW11	SW10	SW9	SW8
0xF6	MAT	-	-	-	-	-	-	-
R/W	R/W	R/W	R/W	R/W	R/W	R/W	R/W	R/W
Initial val.	0	0	0	0	0	0	0	0

【0xF7-0xF9 : Clear continuous touch】

Name: CLR_DETECT_CONT
Address: 0xF7-0xF9

Description: DETECT_CONT Clear Register. Clears the DETECT_CONT by writing '0' these registers. If you write '1', the operation is invalid. SW 0-15 has each clear bit, cause SW 0-15 supports multiple pressed. The matrix key's DETECT_CONT clear bit is 1bit for MAT, cause the matrix key does not correspond to multiple press.
1 : Invalid. 0 :Clear.

	Bit7	Bit6	Bit5	Bit4	Bit3	Bit2	Bit1	Bit0
0xF7	SW7	SW6	SW5	SW4	SW3	SW2	SW1	SW0
0xF8	SW15	SW14	SW13	SW12	SW11	SW10	SW9	SW8
0xF9	MAT	-	-	-	-	-	-	-
R/W	R/W	R/W	R/W	R/W	R/W	R/W	R/W	R/W
Initial val.	0	0	0	0	0	0	0	0

【0xFA : LED drivers control】

Name: LED_CH

Address: 0xFA

Description: This register controls the LED drivers.
1 : On (High drive). 0 : Off (Low drive).

	Bit7	Bit6	Bit5	Bit4	Bit3	Bit2	Bit1	Bit0
0xFA	LED7	LED6	LED5	LED4	LED3	LED2	LED1	LED0
R/W	R/W	R/W	R/W	R/W	R/W	R/W	R/W	R/W
Initial val.	0	0	0	0	0	0	0	0

【0xFB : Clear interrupt of PWM continuous flashing】

Name: CLR_DETECT_PWM_FINISH

Address: 0xFB

Description: DETECT_PWM_FINISH Clear Register. Clears the DETECT_PWM_FINISH by writing '0' these registers.
If you write '1', the operation is invalid. LED 0-7 has each clear bit.
1 : Invalid. 0 :Clear.

	Bit7	Bit6	Bit5	Bit4	Bit3	Bit2	Bit1	Bit0
0xFB	LED7	LED6	LED5	LED4	LED3	LED2	LED1	LED0
R/W	R/W	R/W	R/W	R/W	R/W	R/W	R/W	R/W
Initial val.	0	0	0	0	0	0	0	0

【0xFE : Write register for operation check of CPU】

Name: WACT

Address: 0xFE

Description: This register is a write register for operational check of the IC. The value written to this register for operation check is copied to register for operation check (Address is 0x1E). Comparing the write value with the read value is equal, CPU and I/F are operating normally.

	Bit7	Bit6	Bit5	Bit4	Bit3	Bit2	Bit1	Bit0
0xFE	WACT[7]	WACT[6]	WACT[5]	WACT[4]	WACT[3]	WACT[2]	WACT[1]	WACT[0]
R/W	R/W	R/W	R/W	R/W	R/W	R/W	R/W	R/W
Initial val.	0	0	0	0	0	0	0	0

[0xFF : AFE control]

Name: CNT
 Address: 0xFF
 Description: This register is for control of AFE.

ACT : Scan Enable :

This bit is the scan enable for sensors. 1:Scan Enable. 0:Scan Disable.

CAL : Act Software-calibration :

This bit is the act software-calibration. Writing '1' to this bit, the calibration sequence is executed. When software calibration is complete, write '0' to this bit.

CFG : Enable Configuration Value :

Writing '1' to this bit, the values of Sensor Configuration (Address 0xC0-0xCF), Mask Configuration (Address 0xD0-0xDF), PWM Configuration (Address 0xE0-0xEF), FRCRLS and CALOVF are effective to IC's operation.

CALMOD : Select Software-calibration mode :

0: All sensors are the targets for software-calibration. If some sensor has the value more than the threshold for "Off→On", the sensors are changed to OFF, and DETECT_OFF registers are enable. (default)
 1: Except for the sensor that has the value more than the threshold for "Off→On".

CALOVF : Select Self-calibration mode detected overflow :

When the periodic calibration is active, select to act self-calibration or not to act in the case that the sensor values are over the dynamic range of included ADC.
 0: Act self-calibration(default) 1:Non act self-calibration.

FRCRLS : Select Force OFF at continued touch :

When the continued touch is active, select to force OFF not to do in the case that the max value after detect continued touch minus the current sensor value is more than the threshold for "Off→On".
 0: Non force OFF(default) 1:Act force OFF.
 The continued touch sensor is changed to OFF, and DETECT_OFF register is enable.

	Bit7	Bit6	Bit5	Bit4	Bit3	Bit2	Bit1	Bit0
0xFF	FRCRLS	CALOVF	-	CALMOD	-	CFG	CAL	ACT
R/W	R/W	R/W	-	R/W	-	R/W	R/W	R/W
Initial val.	0	0	-	0	-	0	0	0

Timing Charts

Host interface

2-wire serial bus.
 Compatible with I2C protocol.
 Supports slave mode only.
 Slave Address = 0x5C (BU21072MUV)
 Slave Address = 0x5D (BU21078MUV/BU21078FV)
 Supports Standard-mode (data transfer rate of 100 kbit/s) and Fast-mode (data transfer rate of 400 kbit/s).
 Supports sequential read.

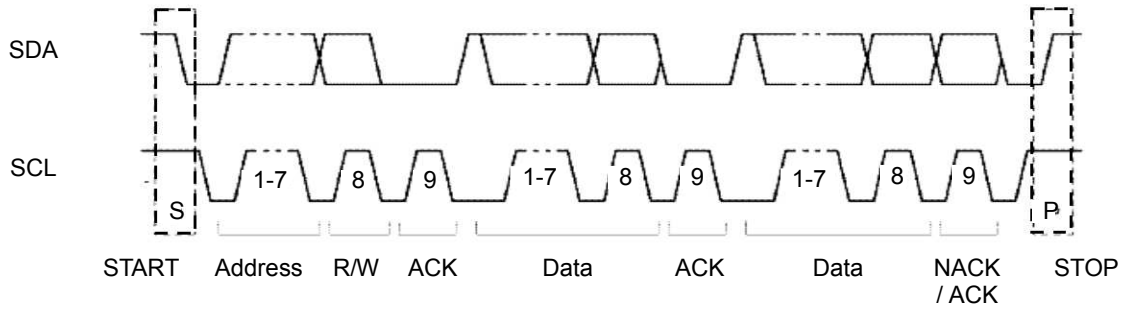

Figure 10. 2-wire serial bus data format

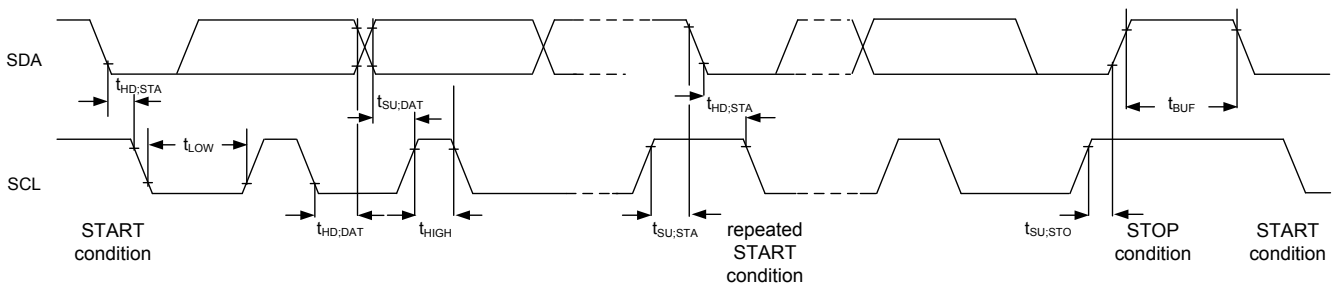
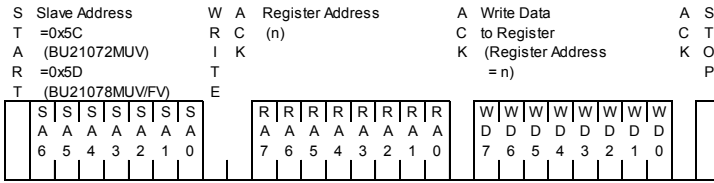

Figure 11. 2-wire serial bus timing chart

Parameter	Symbol	Standard-mode		Fast-mode		Unit
		MIN	MAX	MIN	MAX	
SCL clock frequency	f_{SCL}	0	100	0	400	kHz
Hold time (repeated) START condition	$t_{HD,STA}$	4.0	-	0.6	-	usec
LOW period of the SCL clock	t_{LOW}	4.7	-	1.3	-	usec
HIGH period of the SCL clock	t_{HIGH}	4.0	-	0.6	-	usec
Data hold time	$t_{HD,DAT}$	0.1	3.45	0.1	0.9	usec
Data set-up time	$t_{SU,DAT}$	0.25	-	0.1	-	usec
Set-up time for a repeated START condition	$t_{SU,STA}$	4.7	-	0.6	-	usec
Set-up time for STOP condition	$t_{SU,STO}$	4.0	-	0.6	-	usec
Bus free time between a STOP and START condition	t_{BUF}	4.7	-	1.3	-	usec

Byte Write



SA : Slave Address
 RA : Register Address
 RD : Read Data
 WD : Write Data

Random Read

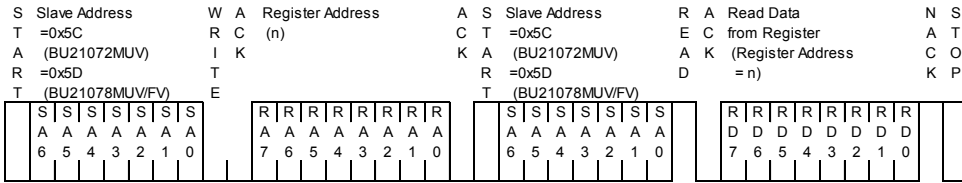

Sequential Read

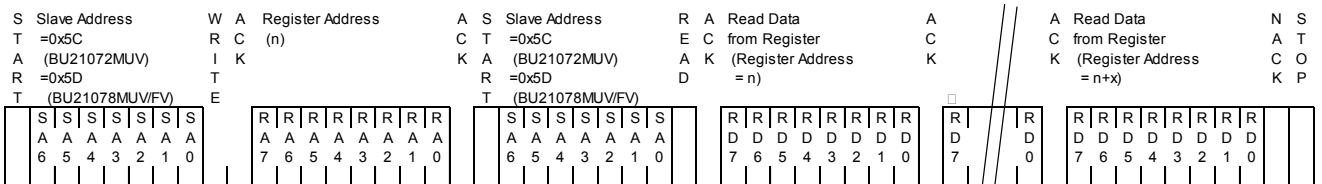

After scan each sensor in time series, MPU convert to the switch operations from the detected results. The number of sensor ports is difference between BU21072MUV and BU21078MUV / BU21078FV, but one scan rate is the same. One scan rate is about 16msec at typical.

Figure 12. 2-wire serial bus protocol

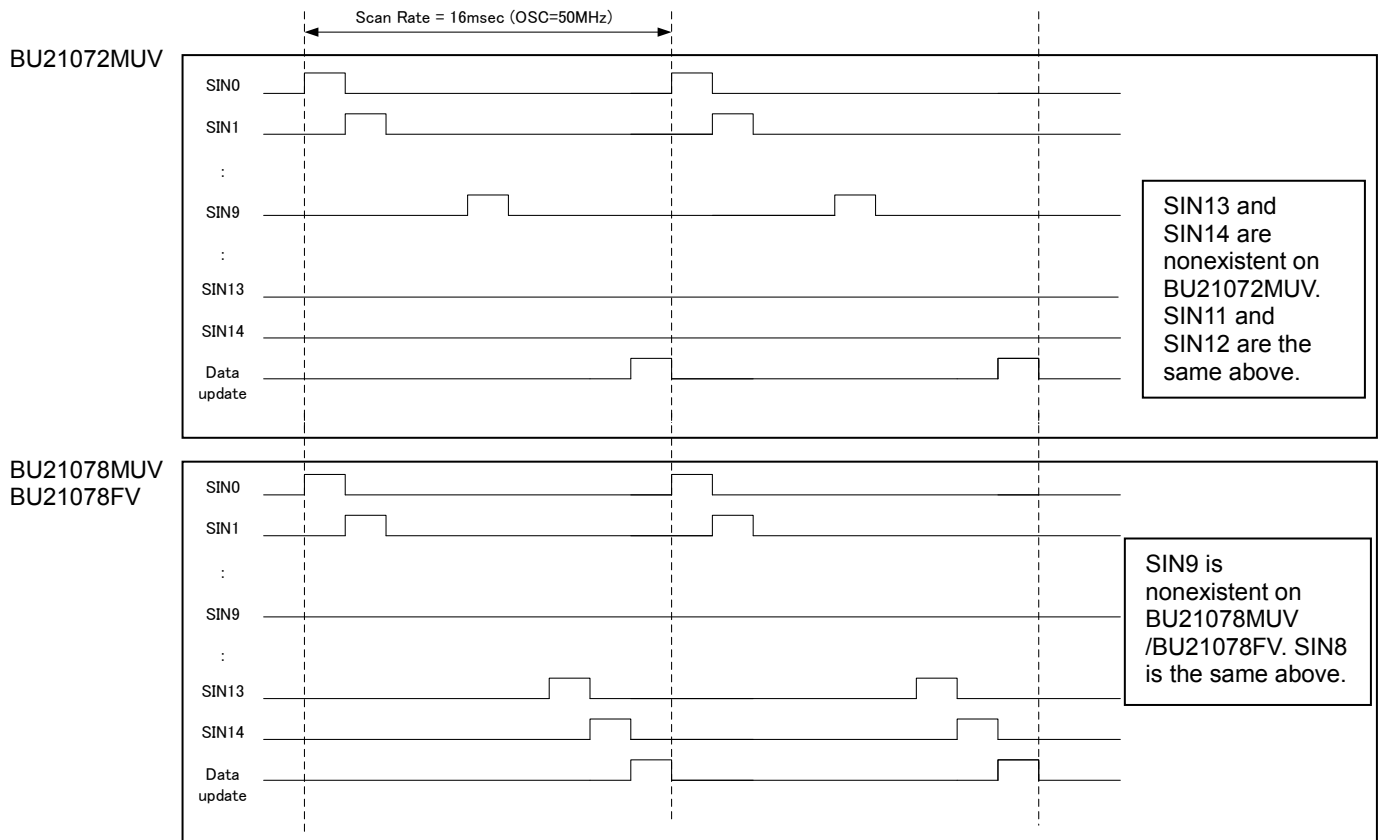

Figure 13. Timing chart of scan rate

Power on sequence

Power supply pin is VDD only. AVDD and DVDD are supplied by each LDO included BU21072/78MUV, so that have no priority about power on sequence. When VDD reaches to the effective voltage, power-on-reset which initializes the digital block is released. Power-On-Reset monitoring VDD, so it should be set to proper value of decoupling capacitor and VDD rise time, so as to rise to the proper voltage (DVDD→VDD).

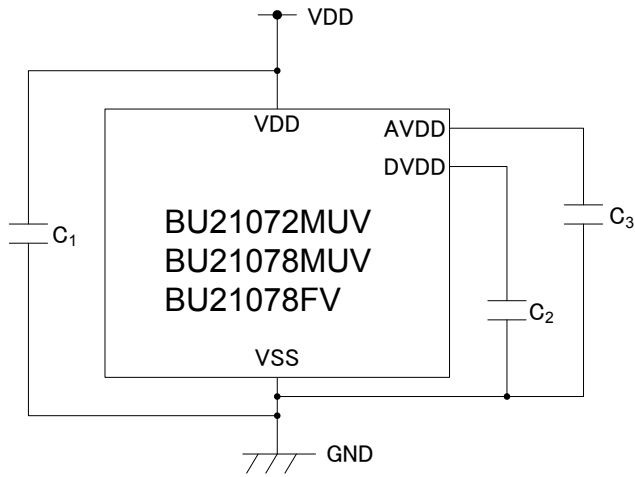

Figure 14. Arrangement of external decoupling capacitors

Recommended value of external capacitors

C1	0.1uF	VDD decoupling capacitor
C2	1.0uF	DVDD decoupling capacitor
C3	2.2uF	AVDD decoupling capacitor

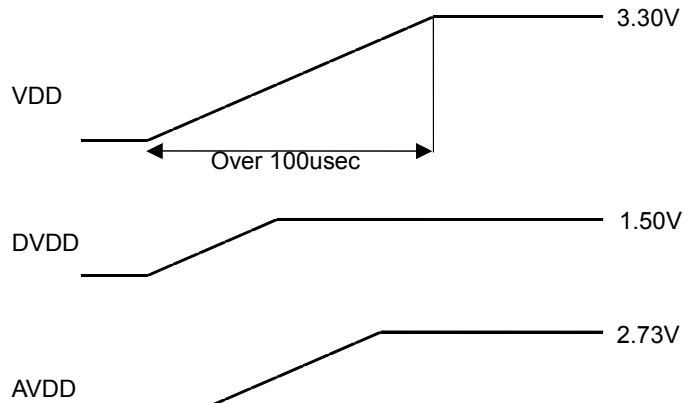

Figure 15. Timing chart of power on sequence

When power-on-reset is released, MPU starts initial sequence. Inform by the INT port to the host that the initialization has been completed. After verify that the initialization has completed, the host will need to resend the command to the IC. In the case that WDTR is released as well, MPU starts initial sequence. If WDTR has released, all registers have been initialized. So the host will need to resend the command to the IC.

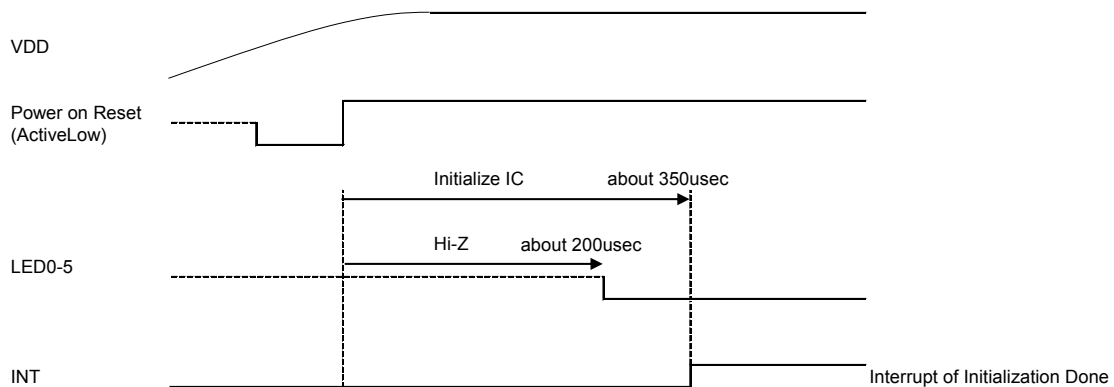

Figure 16. Timing chart of initialization

Initialize operation

This IC is initialized and all registers are cleared by Power-on reset, WDT time-out reset, and Software reset command. When initialization is complete, the register INI is set to '1' and I/O port INT is set to "H". After the IC is initialized, write the configuration values to registers. After setting configuration values, the next action is sensor calibration. Set '1' to the registers ACT, CFG and CAL on Address 0xFF, so calibration sequence is performed.

• IC's initialization after hardware reset

- Power-on-reset
- WDT time-out-reset
- Software reset command

The above actions act hardware reset to the IC. Hardware reset clear the all registers to the default value and initialize MPU. After hardware reset, MPU runs the initial sequence of firmware on Program ROM.

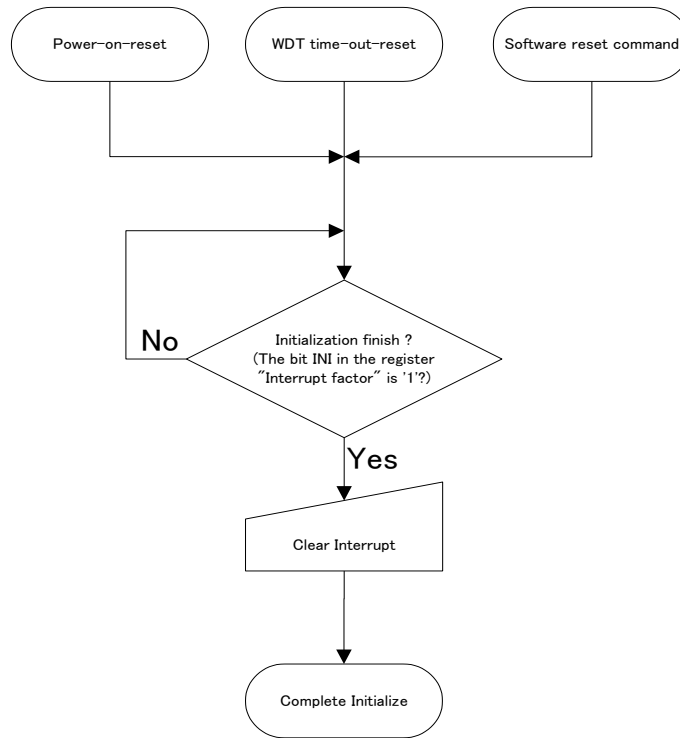

Figure 17. Initialization routine after hardware reset.

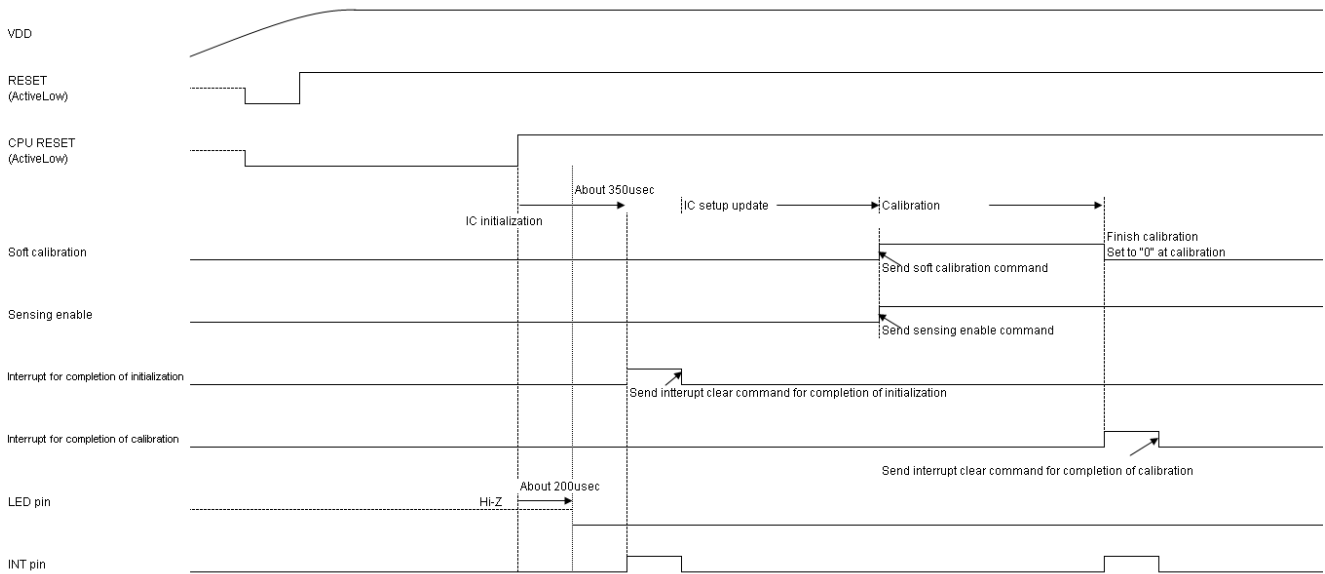

Figure 18. Configuration sequence including clear interrupts.

Calibration

This IC needs the calibration in the cases as follows.

1.After configuration :

After setting of Sensor Configuration (Address 0xC0-0xCF) and being effective to IC's operation (by writing '1' to CFG), the IC needs the calibration. Set '1' to the registers ACT and CAL on Address 0xFF, so calibration sequence is performed.

2.Detect drift condition :

When the IC detects the drift condition, the IC acts self-calibration. When calibration is complete, the interrupt factor register CAL is set to '1' and I/O port INT is set to "H". When there is the sensor with the sensor value more than the threshold for "Off→On", IC does not detect drift condition. The interrupt factor register CAL is maskable by the mask interrupt register CAL. The interrupt factor register CAL is cleared by writing '1' to the interrupt clear register CAL.

3.Detect noise :

When the IC detects the noise, the IC changes the scan rate to not synchronize with the noise, and the IC acts self-calibration. When calibration is complete, the Interrupt factor register CAL is set to '1' and I/O port INT is set to "H". The interrupt factor register CAL is maskable by the mask interrupt register CAL. The interrupt factor register CAL is cleared by writing '1' to the interrupt clear register CAL.

4.Detect incorrect operation :

When the finger is on the sensor at the calibration, the sensor base state is with the finger. Without the finger, the sensor value is under the base state value. This abnormal condition is defined to incorrect operation. Detected incorrect operation, the IC acts self-calibration. The interrupt factor register CAL is maskable by the mask interrupt register CAL. The interrupt factor register CAL is cleared by writing '1' to the interrupt clear register CAL.

Software-calibration

(1) Write '1' to the Act Software-calibration bit.

(2) Finishing the calibration, the Software-calibration finish bit (CAL on Address0x10) is set to '1' and I/O port INT is set to "H". For next calibration, clear the interrupt.

Operating software-calibration, sensor values and switch result is cleared.

In the act of calibration, sensor values are not changed. So the switching operations are invalid.

If the software-calibration is released at sensing sensors, IC acts calibration at next sensing sensors.

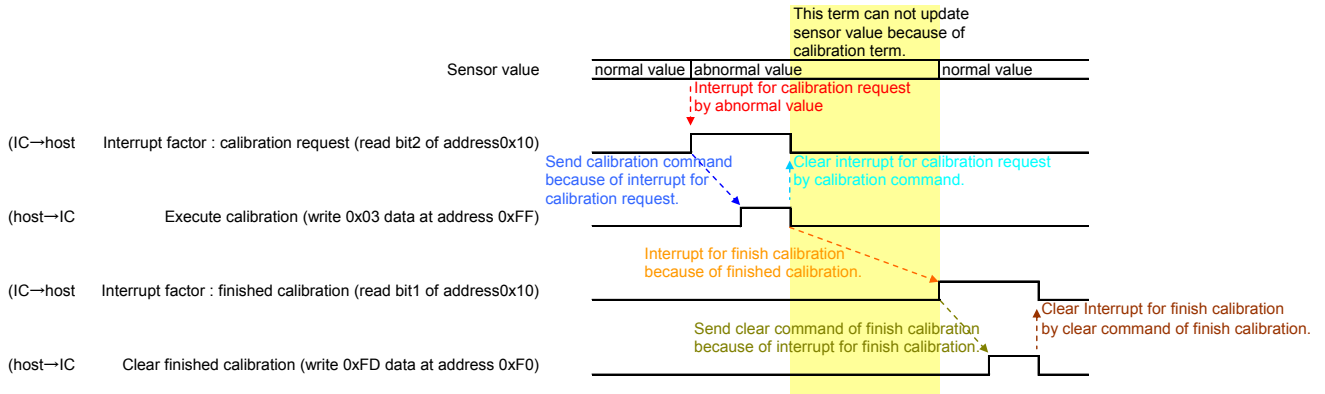

Figure 19. Software calibration sequence

LED calibration

When LED drivers operation is (Host accesses to Address 0xFA), this IC is selectable whether to perform self-calibration. Selecting whether to perform the LED calibration is defined by the configuration for calibration register (LEDCAL on Address0xEF).

If there is the access to the register for LED drivers operation (access to Address 0xFA) when the finger on the sensors. Incorrect operation will be detected at the finger leaving, and so IC will act self-calibration.

Periodical calibration

The periodical calibration is to perform self-calibration periodically. This IC is selectable whether to perform periodical calibration. Selecting whether to perform the periodical calibration is defined by the configuration for calibration register (PERCAL on Address0xEF).

The sensor with the finger is not calibrated by the periodical calibration.

Whenever periodical calibration is complete, the interrupt factor register PERCAL is set to '1' and I/O port INT is set to "H". The interrupt factor register PERCAL is maskable by the mask interrupt register PERCAL. The interrupt factor register CAL is cleared by writing '1' to the interrupt clear register PERCAL.

Matrix Switch

The cross points of the sensors which are arranged in a matrix are able to assigned to individual switches. The matrix layout of the sensors is Figure 20.

Each matrix switch has the registers of detected Touch(DETECT_ON) / Release(DETECT_OFF) / Hold(DETECT_COND) operations. Not used matrix switches are maskable. If there are the unstructured matrix switches (in the case that under 6x6 matrix layout), it is must that the unstructured matrix switches is masked. Matrix switches do not support to multi-detect Touch/Release/Hold. The condition of acceptable matrix switch operation is that every sensor's value is under the threshold for "On→Off" and DETECT_OFF register of matrix switch is cleared. It is must that the matrix switches that are made by the sensor assigned to a simple switch are masked.

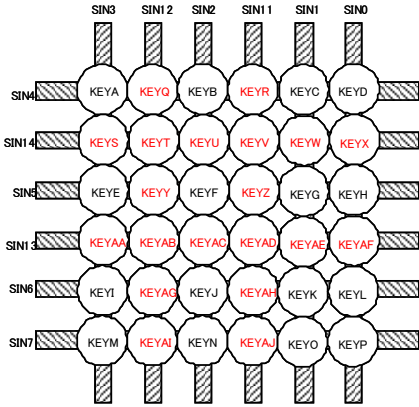

KEYA : KEY[5:0] = 0x00	KEYM : KEY[5:0] = 0x0C	KEYY : KEY[5:0] = 0x18
KEYB : KEY[5:0] = 0x01	KEYN : KEY[5:0] = 0x0D	KEYZ : KEY[5:0] = 0x19
KEYG : KEY[5:0] = 0x02	KEYO : KEY[5:0] = 0x0E	KEYAA : KEY[5:0] = 0x1A
KEYD : KEY[5:0] = 0x03	KEYP : KEY[5:0] = 0x0F	KEYAB : KEY[5:0] = 0x1B
KEYE : KEY[5:0] = 0x04	KEYQ : KEY[5:0] = 0x10	KEYAC : KEY[5:0] = 0x1C
KEYF : KEY[5:0] = 0x05	KEYR : KEY[5:0] = 0x11	KEYAD : KEY[5:0] = 0x1D
KEYG : KEY[5:0] = 0x06	KEYS : KEY[5:0] = 0x12	KEYAE : KEY[5:0] = 0x1E
KEYH : KEY[5:0] = 0x07	KEYT : KEY[5:0] = 0x13	KEYAF : KEY[5:0] = 0x1F
KEYI : KEY[5:0] = 0x08	KEYU : KEY[5:0] = 0x14	KEYAG : KEY[5:0] = 0x20
KEYJ : KEY[5:0] = 0x09	KEYV : KEY[5:0] = 0x15	KEYAH : KEY[5:0] = 0x21
KEYK : KEY[5:0] = 0x0A	KEYW : KEY[5:0] = 0x16	KEYAI : KEY[5:0] = 0x22
KEYL : KEY[5:0] = 0x0B	KEYX : KEY[5:0] = 0x17	KEYAJ : KEY[5:0] = 0x23

Figure 20. Layout for matrix switch

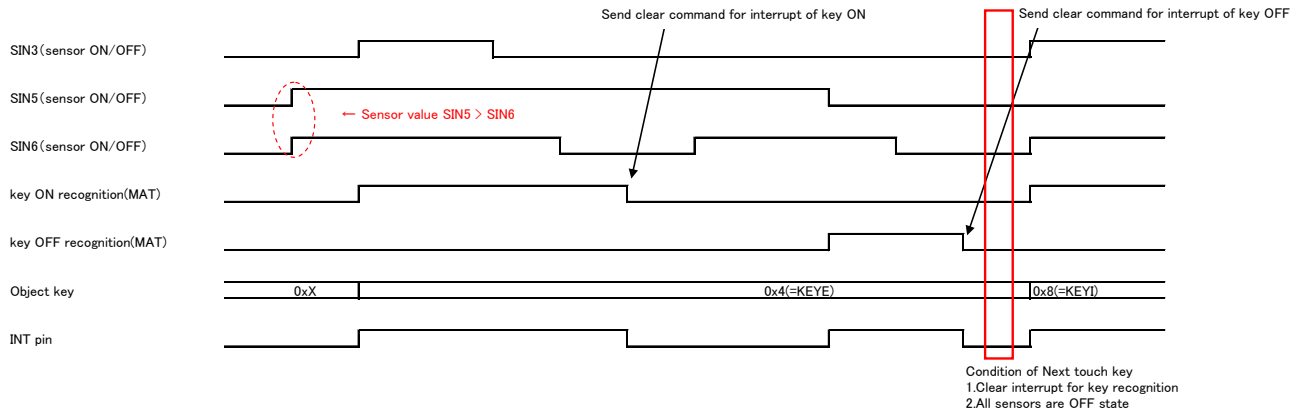

Figure 21. Interrupt of matrix switch (1)

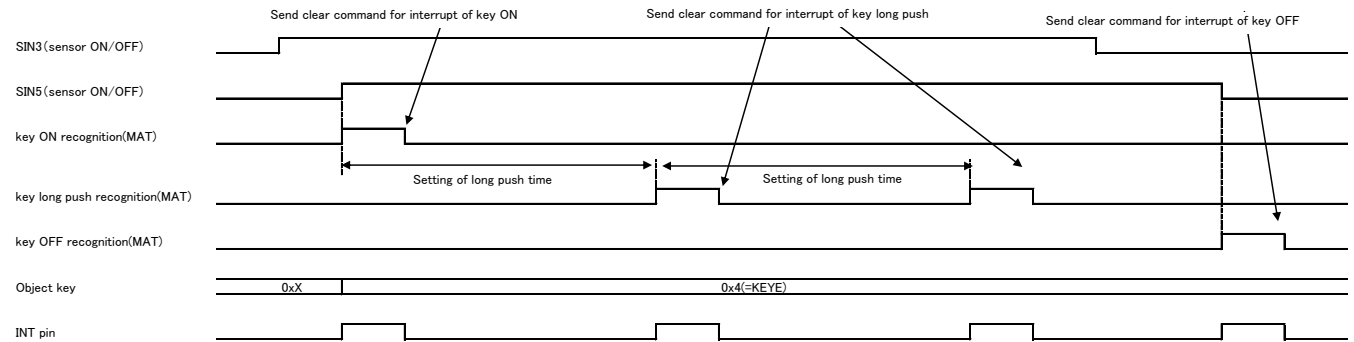

Figure 22. Interrupt of matrix switch (2)