



Chipsmall Limited consists of a professional team with an average of over 10 year of expertise in the distribution of electronic components. Based in Hongkong, we have already established firm and mutual-benefit business relationships with customers from,Europe,America and south Asia,supplying obsolete and hard-to-find components to meet their specific needs.

With the principle of “Quality Parts,Customers Priority,Honest Operation,and Considerate Service”,our business mainly focus on the distribution of electronic components. Line cards we deal with include Microchip,ALPS,ROHM,Xilinx,Pulse,ON,Everlight and Freescale. Main products comprise IC,Modules,Potentiometer,IC Socket,Relay,Connector.Our parts cover such applications as commercial,industrial, and automotives areas.

We are looking forward to setting up business relationship with you and hope to provide you with the best service and solution. Let us make a better world for our industry!



Contact us

Tel: +86-755-8981 8866 Fax: +86-755-8427 6832

Email & Skype: info@chipsmall.com Web: www.chipsmall.com

Address: A1208, Overseas Decoration Building, #122 Zhenhua RD., Futian, Shenzhen, China



BCD-to-decimal decoder

BU4028B

The BU4028B is a decoder which converts BCD signals to decimal signals.

Of the ten outputs Q_0 to Q_9 , those corresponding to the A to D input codes are set to "H", and the others are all set to "L".

If inputs A to C are used and input D is used as disabled input, the BU4028B can also be used as a 1-of-8 decoder.

●Features

- 1) Low power dissipation.
- 2) Wide range of operating power supply voltages.
- 3) High input impedance.
- 4) High fan-out.
- 5) Direct drive of 2 L-TTL inputs and 1LS-TTL input.

●Block diagram

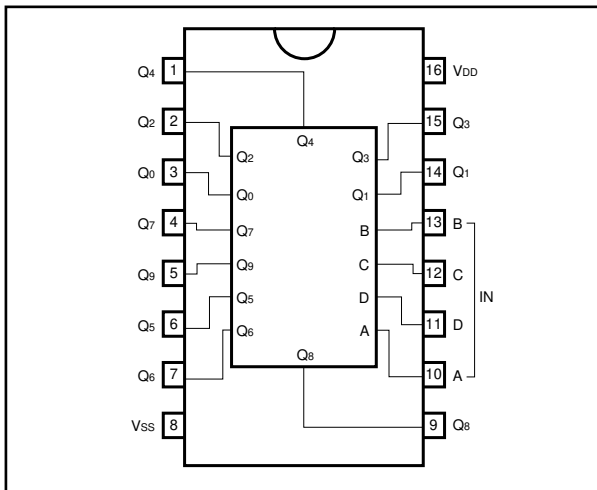

●Logic circuit diagram

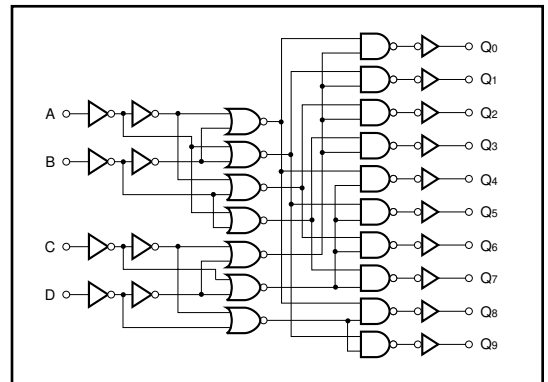

● Truth table

INPUT				OUTPUT									
D	C	B	A	Q ₉	Q ₈	Q ₇	Q ₆	Q ₅	Q ₄	Q ₃	Q ₂	Q ₁	Q ₀
L	L	L	L	L	L	L	L	L	L	L	L	L	H
L	L	L	H	L	L	L	L	L	L	L	L	H	L
L	L	H	L	L	L	L	L	L	L	L	H	L	L
L	L	H	H	L	L	L	L	L	L	H	L	L	L
L	H	L	L	L	L	L	L	L	H	L	L	L	L
L	H	L	H	L	L	L	L	H	L	L	L	L	L
L	H	H	L	L	L	L	H	L	L	L	L	L	L
L	H	H	H	L	L	H	L	L	L	L	L	L	L
H	L	L	L	L	H	L	L	L	L	L	L	L	L
H	L	L	H	L	L	L	L	L	L	L	L	L	L
H	L	H	L	L	L	L	L	L	L	L	L	L	L
H	L	H	H	L	L	L	L	L	L	L	L	L	L
H	H	L	L	L	L	L	L	L	L	L	L	L	L
H	H	L	H	L	L	L	L	L	L	L	L	L	L
H	H	H	L	L	L	L	L	L	L	L	L	L	L
H	H	H	H	L	L	L	L	L	L	L	L	L	L

● Absolute maximum ratings (Ta = 25°C, V_{SS} = 0V)

Parameter	Symbol	Limits	Unit
Power supply voltage	V _{DD}	- 0.3 ~ + 18	V
Power dissipation	P _d	1000 (DIP)	mW
Operating temperature	T _{opr}	- 40 ~ + 85	°C
Storage temperature	T _{stg}	- 55 ~ + 150	°C
Input voltage	V _{IN}	- 0.3 ~ V _{DD} + 0.3	V

● Electrical characteristics

DC characteristics (unless otherwise noted, $T_a = 25^\circ\text{C}$, $V_{SS} = 0\text{V}$)

Parameter	Symbol	Min.	Typ.	Max.	Unit	V _{DD} (V)	Conditions	Measurement circuit
Input high level voltage	V _{IH}	3.5	—	—	V	5	—	Fig.1
		7.0	—	—		10		
		11.0	—	—		15		
Input low level voltage	V _{IL}	—	—	1.5	V	5	—	Fig.1
		—	—	3.0		10		
		—	—	4.0		15		
Input high level current	I _{IH}	—	—	0.3	μA	15	V _{IH} = 15V	Fig.1
Input low level current	I _{IL}	—	—	-0.3	μA	15	V _{IL} = 0V	Fig.1
Output high level voltage	V _{OH}	4.95	—	—	V	5	I _o = 0mA	Fig.1
		9.95	—	—		10		
		14.95	—	—		15		
Output low level voltage	V _{OL}	—	—	0.05	V	5	I _o = 0mA	Fig.1
		—	—	0.05		10		
		—	—	0.05		15		
Output high level current	I _{OH}	-0.16	—	—	mA	5	V _{OH} = 4.6V	Fig.1
		-0.4	—	—		10	V _{OH} = 9.5V	
		-1.2	—	—		15	V _{OH} = 13.5V	
Output low level current	I _{OL}	0.44	—	—	mA	5	V _{OL} = 0.4V	Fig.1
		1.1	—	—		10	V _{OL} = 0.5V	
		3.0	—	—		15	V _{OL} = 1.5V	
Static current dissipation	I _{DD}	—	—	1	μA	5	V _i = V _{DD} or GND	—
		—	—	2		10		
		—	—	4		15		

Switching characteristics (Ta = 25°C, CL = 50pF, VSS = 0V)

Parameter	Symbol	Min.	Typ.	Max.	Unit	VDD (V)	Conditions	Measurement circuit
Output rise time	t _{TLH}	—	180	—	ns	5	—	Fig.2,3
		—	90	—		10		
		—	65	—		15		
Output fall time	t _{THL}	—	100	—	ns	5	—	Fig.2,3
		—	50	—		10		
		—	40	—		15		
“L” to “H” propagation delay time	t _{PLH}	—	300	—	ns	5	—	Fig.2,3
		—	130	—		10		
		—	90	—		15		
“H” to “L” propagation delay time	t _{PHL}	—	300	—	ns	5	—	Fig.2,3
		—	130	—		10		
		—	90	—		15		
Input capacitance	C _{IN}	—	5	—	pF	—	—	—

● Measurement circuits

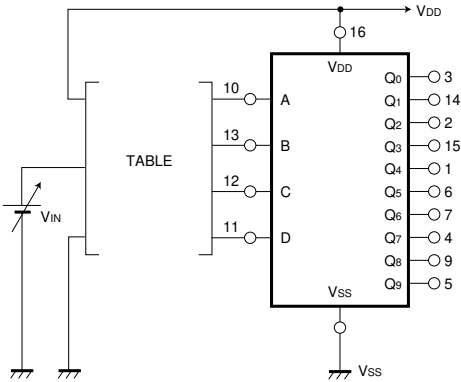
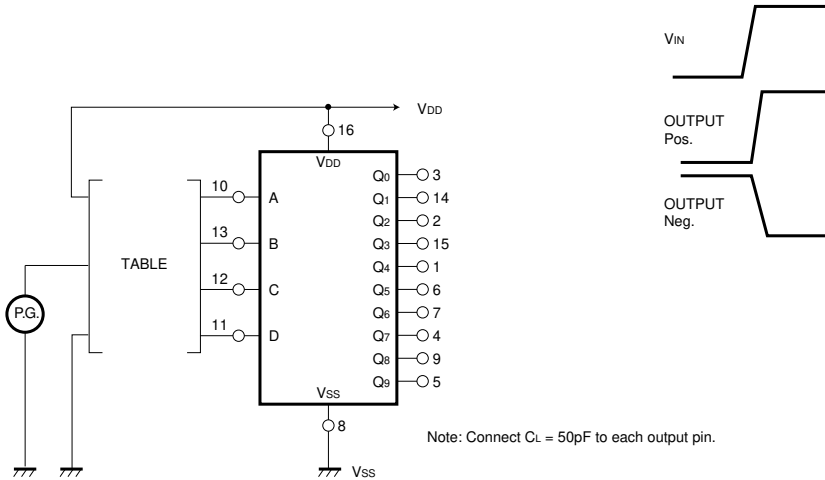

Fig. 1 DC characteristics measurement circuit

TEST NO.	INPUT				OUTPUT	
	A	B	C	D	Pos.	Neg.
1	V _{IN}	V _{SS}	V _{SS}	V _{SS}	Q ₁	Q ₀
2	V _{SS}	V _{IN}	V _{DD}	V _{SS}	Q ₆	Q ₄
3	V _{DD}	V _{DD}	V _{IN}	V _{SS}	Q ₇	Q ₃
4	V _{DD}	V _{SS}	V _{SS}	V _{IN}	Q ₉	Q ₁
5	V _{SS}	V _{IN}	V _{SS}	V _{SS}	Q ₂	Q ₀
6	V _{DD}	V _{SS}	V _{IN}	V _{SS}	Q ₅	Q ₁
7	V _{SS}	V _{SS}	V _{SS}	V _{IN}	Q ₈	Q ₀
8	V _{SS}	V _{SS}	V _{IN}	V _{SS}	Q ₄	Q ₀
9	V _{IN}	V _{DD}	V _{SS}	V _{SS}	Q ₃	Q ₂



Note: Connect C_L = 50pF to each output pin.

Fig. 2 Switching characteristics measurement circuit

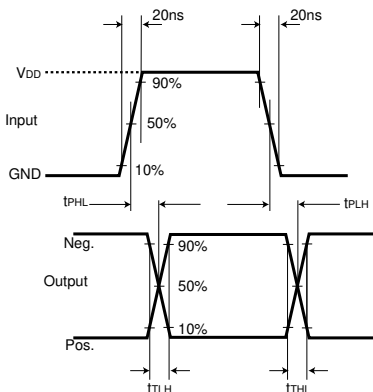

Fig. 3 Switching time test waveform

TEST NO.	INPUT				OUTPUT	
	A	B	C	D	Pos.	Neg.
1	P.G.	V _{SS}	V _{SS}	V _{SS}	Q ₁	Q ₀
2	V _{SS}	P.G.	V _{DD}	V _{SS}	Q ₆	Q ₄
3	V _{DD}	V _{DD}	P.G.	V _{SS}	Q ₇	Q ₃
4	V _{DD}	V _{SS}	V _{SS}	P.G.	Q ₉	Q ₁
5	V _{SS}	P.G.	V _{SS}	V _{SS}	Q ₂	Q ₀
6	V _{DD}	V _{SS}	P.G.	V _{SS}	Q ₅	Q ₁
7	V _{SS}	V _{SS}	V _{SS}	P.G.	Q ₈	Q ₀
8	V _{SS}	V _{SS}	P.G.	V _{SS}	Q ₄	Q ₀
9	P.G.	V _{DD}	V _{SS}	V _{SS}	Q ₃	Q ₂

●Electrical characteristics curve

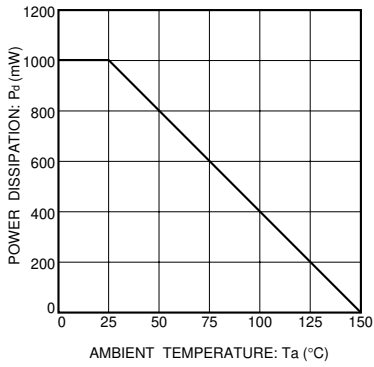
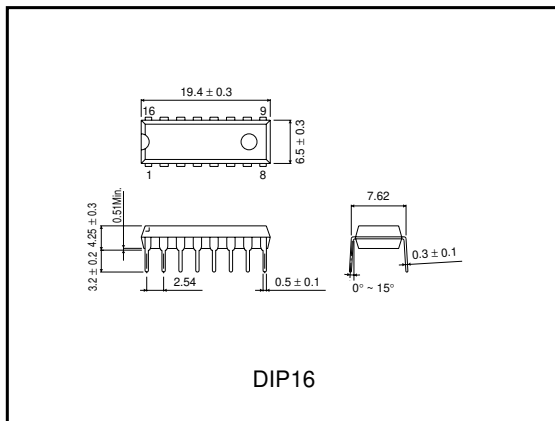

Fig.4 Power dissipation vs. Ta

●External dimensions (Units: mm)



Notes

- No technical content pages of this document may be reproduced in any form or transmitted by any means without prior permission of ROHM CO.,LTD.
- The contents described herein are subject to change without notice. The specifications for the product described in this document are for reference only. Upon actual use, therefore, please request that specifications to be separately delivered.
- Application circuit diagrams and circuit constants contained herein are shown as examples of standard use and operation. Please pay careful attention to the peripheral conditions when designing circuits and deciding upon circuit constants in the set.
- Any data, including, but not limited to application circuit diagrams information, described herein are intended only as illustrations of such devices and not as the specifications for such devices. ROHM CO.,LTD. disclaims any warranty that any use of such devices shall be free from infringement of any third party's intellectual property rights or other proprietary rights, and further, assumes no liability of whatsoever nature in the event of any such infringement, or arising from or connected with or related to the use of such devices.
- Upon the sale of any such devices, other than for buyer's right to use such devices itself, resell or otherwise dispose of the same, no express or implied right or license to practice or commercially exploit any intellectual property rights or other proprietary rights owned or controlled by
- ROHM CO., LTD. is granted to any such buyer.
- Products listed in this document use silicon as a basic material.
Products listed in this document are no antiradiation design.

The products listed in this document are designed to be used with ordinary electronic equipment or devices (such as audio visual equipment, office-automation equipment, communications devices, electrical appliances and electronic toys).

Should you intend to use these products with equipment or devices which require an extremely high level of reliability and the malfunction of which would directly endanger human life (such as medical instruments, transportation equipment, aerospace machinery, nuclear-reactor controllers, fuel controllers and other safety devices), please be sure to consult with our sales representative in advance.

About Export Control Order in Japan

Products described herein are the objects of controlled goods in Annex 1 (Item 16) of Export Trade Control Order in Japan.

In case of export from Japan, please confirm if it applies to "objective" criteria or an "informed" (by MITI clause) on the basis of "catch all controls for Non-Proliferation of Weapons of Mass Destruction.