



Chipsmall Limited consists of a professional team with an average of over 10 year of expertise in the distribution of electronic components. Based in Hongkong, we have already established firm and mutual-benefit business relationships with customers from,Europe,America and south Asia,supplying obsolete and hard-to-find components to meet their specific needs.

With the principle of "Quality Parts,Customers Priority,Honest Operation,and Considerate Service",our business mainly focus on the distribution of electronic components. Line cards we deal with include Microchip,ALPS,ROHM,Xilinx,Pulse,ON,Everlight and Freescale. Main products comprise IC,Modules,Potentiometer,IC Socket,Relay,Connector.Our parts cover such applications as commercial,industrial, and automotives areas.

We are looking forward to setting up business relationship with you and hope to provide you with the best service and solution. Let us make a better world for our industry!



## Contact us

Tel: +86-755-8981 8866 Fax: +86-755-8427 6832

Email & Skype: info@chipsmall.com Web: www.chipsmall.com

Address: A1208, Overseas Decoration Building, #122 Zhenhua RD., Futian, Shenzhen, China



## AIE Adaptive Image Enhancer Series

# Video Encoders built-in Image Correction


**BU6520KV, BU6521KV**

No.10060ECT03

**●Description**

BU6520KV, BU6521KV are video encoders with built-in AIE image correcting function. Also, BU6521KV has the image correcting function of the fog reduction, too.

Fog Reduction, the brightness correction, the backlight correction and the chroma emphasis can improve the visibility of the input image of the camera.

\* AIE and Fog Reduction function are image processing technology by ROHM's hardware.

**●Features**

- 1) Format of video output is compatible with NTSC/PAL composite video format (CVBS).  
Built-in DAC with direct 75Ω drive capability.
- 2) Built-in Fog Reduction function<sup>\*1</sup>, dynamic range correction, edge-emphasizing filter and gamma filter.
- 3) Input/output data format is compatible with ITU-R BT.656 and YCbCr=4:2:2 with synchronization signal.
- 4) Compatible with NTSC (27MHz, 28.63636MHz and 19.06993MHz)/  
PAL(27MHz, 28.375MHz, 35.46895MHz and 18.9375MHz)<sup>\*2</sup>.
- 5) Registers can be set up with a 2-line serial interface.
- 6) Registers can be automatically set up by reading from external EEPROM, when after resetting or changing mode.

<sup>\*1</sup> As for the Fog Reduction feature, it loads only BU6521KV.

<sup>\*2</sup> NTSC 19,06993 MHz and PAL 18,9375 MHz support only BU6521KV.

**●Applications**

Security camera, camera for automotive, drive recorder etc.

**●Line up matrix**

Part No.	Power Supply Voltage(V)	Image size	Input Interface	Control Interface	Output Interface	Feature	Temperature Operating Range(°C)	Package
BU6520KV	1.4 to 1.6 (V <sub>DD</sub> Core) 2.7 to 3.6 (V <sub>DD</sub> I/O, AV <sub>DD</sub> )	720x480, SD size	8bit, YUV=4:2:2, ITU-R BT.656	I <sup>2</sup> C, Serial EEPROM interface	8bit, YUV=4:2:2, ITU-R BT.656	AIE, Video output	-40 ~ +85	VQFP48C
BU6521KV	1.4 to 1.6 (V <sub>DD</sub> Core) 2.7 to 3.6 (V <sub>DD</sub> I/O, AV <sub>DD</sub> )	720x480, SD size	8bit, YUV=4:2:2, ITU-R BT.656	I <sup>2</sup> C, Serial EEPROM interface	8bit, YUV=4:2:2, ITU-R BT.656	AIE, Fog reduction, Video output	-40 ~ +85	VQFP48C

I<sup>2</sup>C BUS is a registered trademark of Philips

### ● Absolute maximum ratings

Parameter	Symbol	Rating	Unit
Supply voltage1 (IO)	VDDIO	-0.3~+4.2	V
Supply voltage2 (IO)	VDDI2C	-0.3~+4.2	V
Supply voltage3 (DAC)	AVDD	-0.3~+4.2	V
Supply voltage4 (CORE)	VDD	-0.3~+2.1	V
Input voltage range	VIN	-0.3~IO_LVL+0.3 <sup>*1</sup>	V
Storage temperature range	Tstg	-40~+125	°C
Power dissipation	PD	400 <sup>*2</sup> , 900 <sup>*3</sup>	mW

\*1 IO\_LVL is a generic name of VDDIO, VDDI2C, and AVDD.

\*2 IC only. In the case exceeding 25°C, 4.0mW should be reduced at the rating 1°C.

\*3 When packaging a glass epoxy board of 70x70x1.6mm. If exceeding 25°C, 9.0mW should be reduced at the rating 1°C.

\* Has not been designed to withstand radiation.

\* Operation is not guaranteed at absolute maximum ratings.

### ● Operating conditions

Parameter	Symbol	Ratings	Unit
Supply voltage 1 (IO)	VDDIO	2.70 ~ 3.60 (Typ.: 3.30)	V
Supply voltage 2 (IO)	VDDI2C	2.70 ~ 3.60 (Typ.: 3.30)	V
Supply voltage 3 (DAC)	AVDD	2.70 ~ 3.60 (Typ.: 3.30)	V
Supply voltage 4 (CORE)	VDD	1.40 ~ 1.60 (Typ.: 1.50)	V
Input voltage range	VIN	0.00 ~ IO_LVL <sup>*1</sup>	V
Operating temperature range	Topr	-40 ~ +85	°C

\*1 IO\_LVL is a generic name of VDDIO, VDDI2C, and AVDD.

\* Please supply power source in order of VDD→(VDDIO, VDDI2C, and AVDD).

● Block Diagram

[BU6520KV]

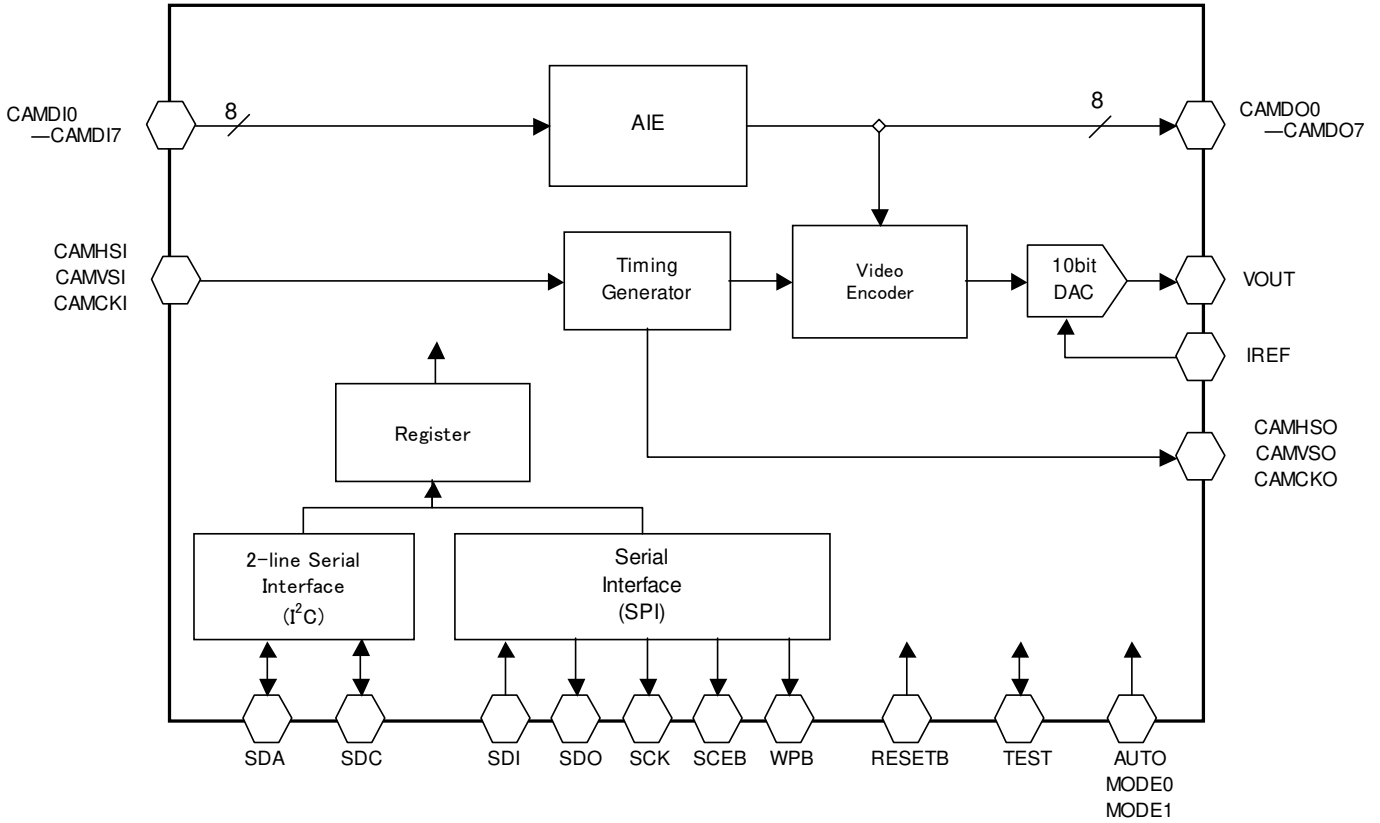


Fig.1 BU6520KV Block Diagram

[BU6521KV]

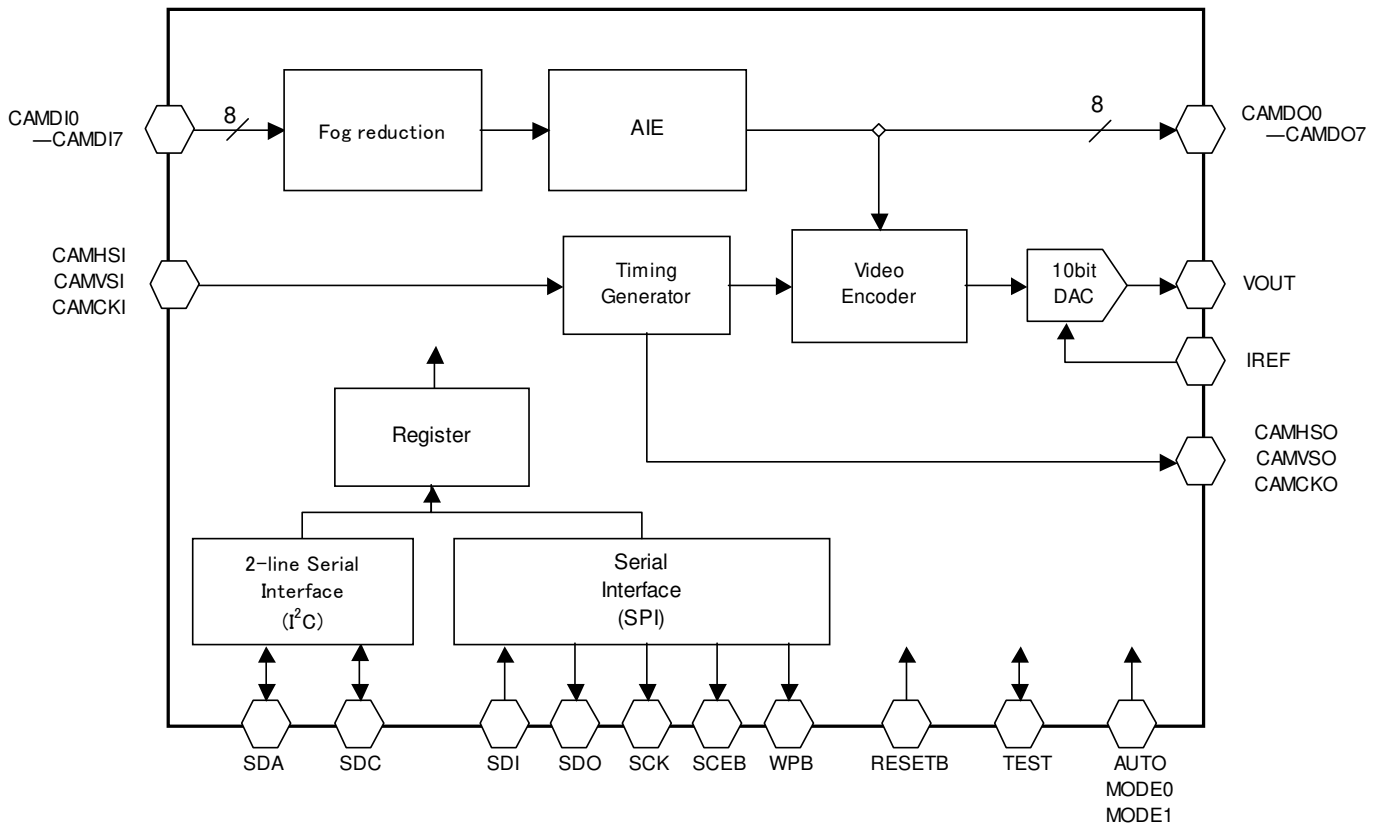


Fig.2 BU6521KV Block Diagram



## ● Pin functional descriptions • Equivalent circuit

PIN No.	PIN Name	In/Out	Active Level	Init	Function explanation	Power Source System	I/O type <sup>*1</sup>
1	SDI	In	DATA	-	SPI-bus data input	1	A
2	CAMDI7	In	DATA	-	Data input bit 7	1	C
3	CAMDI6	In	DATA	-	Data input bit 6	1	C
4	CAMDI5	In	DATA	-	Data input bit 5	1	C
5	CAMDI4	In	DATA	-	Data input bit 4	1	C
6	GND	-	GND	-	Common GROUND	1,2,4	-
7	VDD	-	PWR	-	CORE power source	4	-
8	CAMDI3	In	DATA	-	Data input bit 3	1	C
9	CAMDI2	In	DATA	-	Data input bit 2	1	C
10	CAMDI1	In	DATA	-	Data input bit 1	1	C
11	CAMDI0	In	DATA	-	Data input bit 0	1	C
12	CAMHSI	In	*	-	Horizontal timing input	1	C
13	CAMVSI	In	*	-	Vertical timing input	1	C
14	CAMCKI	In	CLK	-	Clock input	1	E
15	GND	-	GND	-	Common GROUND	1,2,4	-
16	VDDIO	-	PWR	-	Digital IO power source	1	-
17	CAMDO0	Out	DATA	Low	Data output bit 0	1	F
18	CAMDO1	Out	DATA	Low	Data output bit 1	1	F
19	CAMDO2	Out	DATA	Low	Data output bit 2	1	F
20	CAMDO3	Out	DATA	Low	Data output bit 3	1	F
21	CAMDO4	Out	DATA	Low	Data output bit 4	1	F
22	CAMDO5	Out	DATA	Low	Data output bit 5	1	F
23	CAMDO6	Out	DATA	Low	Data output bit 6	1	F
24	CAMDO7	Out	DATA	Low	Data output bit 7	1	F

※ "\*" in the Active Level column indicates that it may be changed during set-up of the register.

※ Init column indicates pin status when released from reset.

※ In the power system column, "1" stands for VDDIO, "2" stands for VDDI2C, "3" stands for AVDD, "4" stands for VDD.

\*1 Fig.3 Equivalent Circuit Structures of input / output pins reference

PIN No.	PIN Name	In/Out	Active Level	Init	Function explanation	Power Source System	I/O type <sup>*1</sup>
25	CAMHSO	Out	*	Low	Horizontal timing output	1	F
26	CAMVSO	Out	*	Low	Vertical timing output	1	F
27	CAMCKO	Out	CLK	Low	Clock output	1	F
28	GND	-	GND	-	Common GROUND	1,2,4	-
29	VDD	-	PWR	-	CORE power source	4	-
30	AUTO	In	High	PD <sup>*2</sup>	Auto register setting enable signal	1	D
31	MODE0	In	DATA	PD <sup>*2</sup>	Auto register setting mode select bit 0	1	D
32	MODE1	In	DATA	PD <sup>*2</sup>	Auto register setting mode select bit 1	1	D
33	VOUT	Out	Analog	-	Analog composite output	3	H
34	AVSS	-	GND	-	Analog GROUND for DAC	3	-
35	IREF	Out	Analog	-	Reference voltage for DAC	3	I
36	AVDD	-	PWR	-	Analog power source for DAC	3	-
37	GND	-	GND	-	Common GROUND	1,2,4	-
38	VDDI2C	-	PWR	-	Digital IO power source (For 2-line serial interface input/output)	2	-
39	SDA	In/Out	DATA	In	2-line serial interface data input/output	2	G
40	SDC	In/Out	CLK	In	2-line serial interface clock input	2	G
41	RESETB	In	Low	-	System reset signal	1	B
42	TEST	In	High	PD <sup>*2</sup>	Test mode terminal (Connect to GND)	1	D
43	GND	-	GND	-	Common GROUND	1,2,4	-
44	VDDIO	-	PWR	-	Digital IO power source	1	-
45	WPB	Out	Low	Low	Write protect signal to EEPROM	1	F
46	SCEB	Out	Low	High	Chip select signal to EEPROM	1	F
47	SCK	Out	CLK	Low	SPI-bus clock	1	F
48	SDO	Out	DATA	Low	SPI-bus data output	1	F

※ "\*" in the Active Level column indicates that it may be changed during set-up of the register.

※ Init column indicates pin status when released from reset.

※ In the power system column, "1" stands for VDDIO, "2" stands for VDDI2C, "3" stands for AVDD, "4" stands for VDD.

\*1 Fig.3 Equivalent Circuit Structures of input / output pins reference

\*2 Pull-down status.

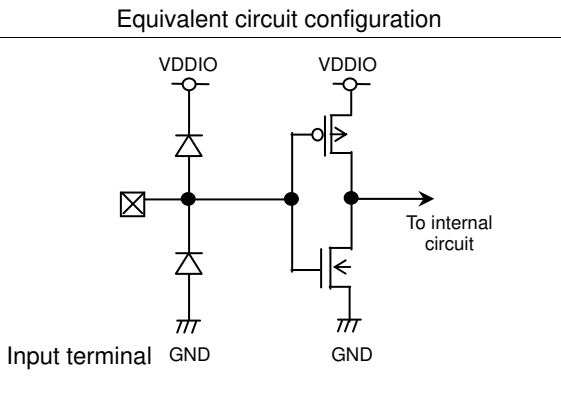
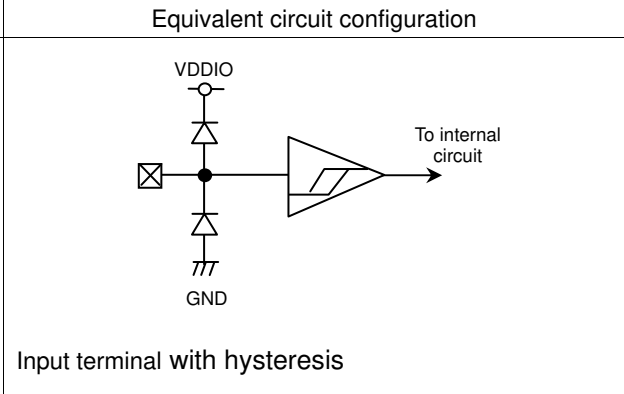
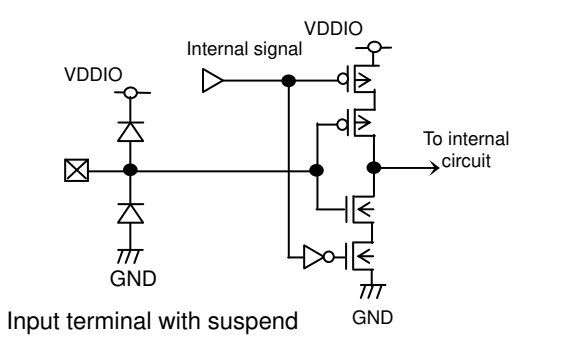
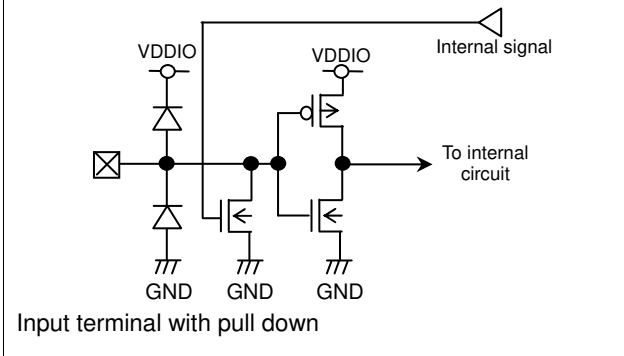
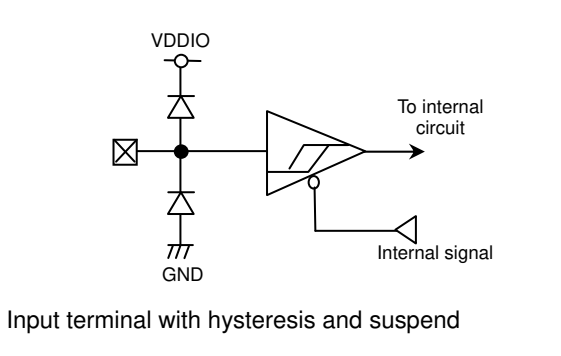
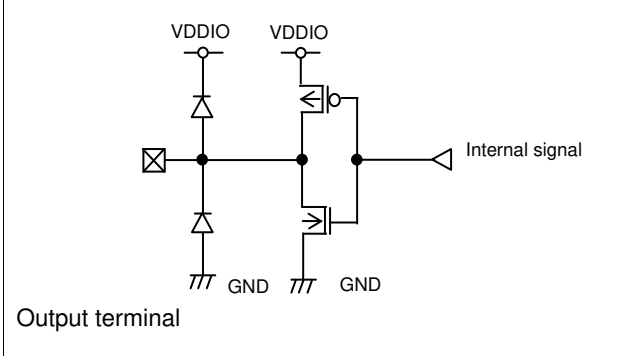
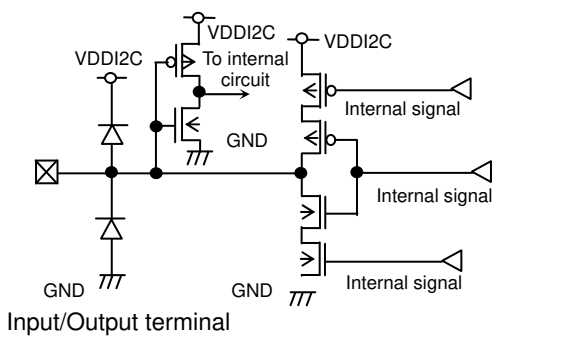
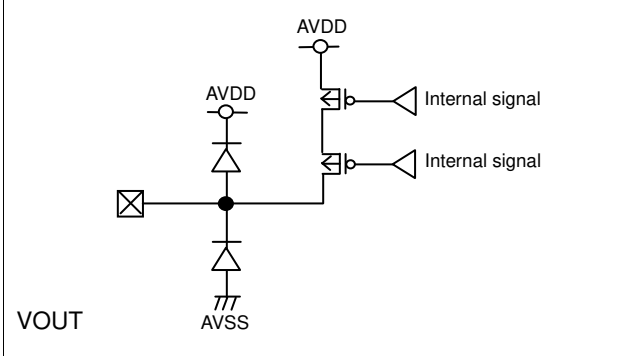
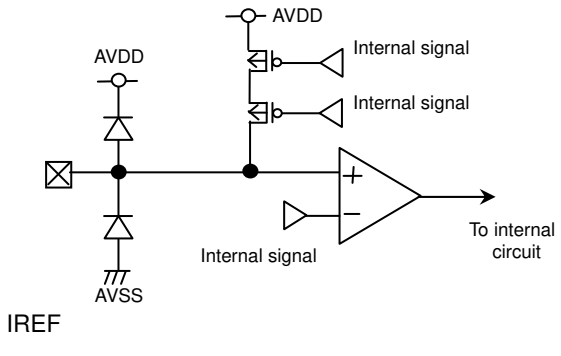
Type	Equivalent circuit configuration	Type	Equivalent circuit configuration
A	 <p>Input terminal</p>	B	 <p>Input terminal with hysteresis</p>
C	 <p>Input terminal with suspend</p>	D	 <p>Input terminal with pull down</p>
E	 <p>Input terminal with hysteresis and suspend</p>	F	 <p>Output terminal</p>
G	 <p>Input/Output terminal</p>	H	 <p>VOUT</p>
I	 <p>IREF</p>		

Fig.3 Equivalent Circuit Structures of input / output pins

● Pin configurations

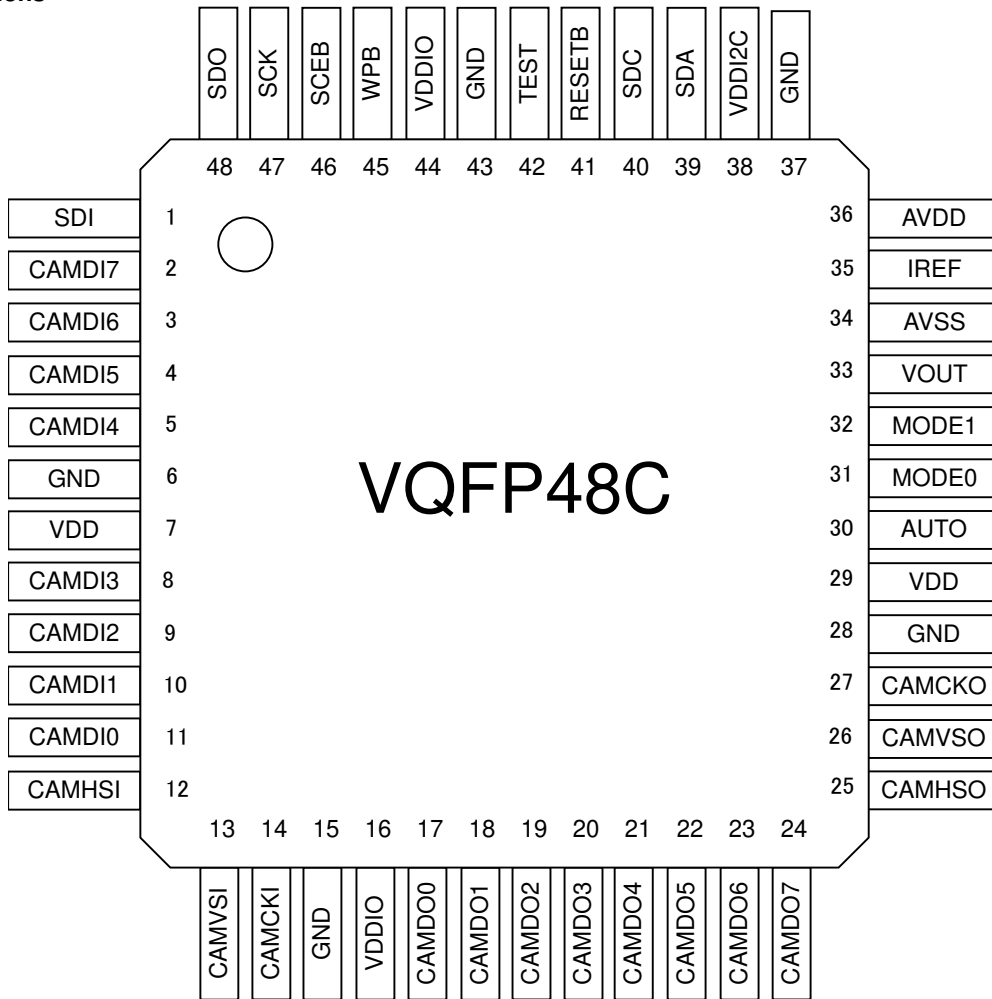


Fig.4 Pin configurations



### ●Electrical characteristics(common)

(Unless otherwise specified VDD=1.50V, VDDIO=3.3V, VDDI2C=3.3V, AVDD=3.3V, GND=0.0V, Ta=25°C, f<sub>IN</sub>=35.5MHz)

Parameter	Symbol	Limits			Unit	Condition	
		MIN.	TYP.	MAX.			
Input frequency	f <sub>IN</sub>	2	-	35.5	MHz	CAMCKI(DUTY45%~55%)	
Supply current (CORE)	BU6520KV	IDD1	-	30	-	mA	35.5MHz operational setting <sup>*1</sup>
	BU6521KV	IDD1	-	40	62	mA	35.5MHz operational setting <sup>*2</sup>
Leakage current (CORE)	IDDst1	-	-	50	μA	At sleep mode setting, input terminal = GND setting	
Supply current (DAC)	BU6520KV	IDD2	-	38	-	mA	RL=37.5Ω, RIREF=2.4kΩ
	BU6521KV	IDD2	-	38	56	mA	RL=37.5Ω, RIREF=2.4kΩ
Leakage current (DAC)	IDDst2	-	-	5	μA	input terminal=GND and DAC power down mode setting	

\*1 Supply current(Total value of current of VDD, VDDIO, and VDDI2C) at color-bar image input in AIE enable and Digital output disable settings.

\*2 Supply current(VDD) at color-bar image input in Fog-Reduction enable, AIE enable and Digital output disable settings.

### ●Electrical characteristics(DC characteristics)

#### 1. DC characteristics (IO)

(Unless otherwise specified VDD=1.50V, VDDIO=3.3V, VDDI2C=3.3V, AVDD=3.3V, GND=0.0V, Ta=25°C)

Parameter	Symbol	Limits			Unit	Condition
		MIN.	TYP.	MAX.		
Input "H" current	I <sub>IH</sub>	-10	-	10	μA	V <sub>IH</sub> =I <sub>O_LVL</sub>
Input "L" current	I <sub>IL</sub>	-10	-	10	μA	V <sub>IL</sub> =GND
Pull-down current	IPD	25	50	100	μA	V <sub>IH</sub> =I <sub>O_LVL</sub>
Input "H" voltage 1	V <sub>IH1</sub>	I <sub>O_LVL</sub> x0.8	-	I <sub>O_LVL</sub> +0.3	V	Normal input (Including input mode of I/O terminal)
Input "L" voltage 1	V <sub>IL1</sub>	-0.3	-	I <sub>O_LVL</sub> x0.2	V	Normal input (Including input mode of I/O terminal)
Input "H" voltage 2	V <sub>IH2</sub>	I <sub>O_LVL</sub> x0.85	-	I <sub>O_LVL</sub> +0.3	V	Hysteresis input (RESETB, CAMCKI, AUTO, MODE0, MODE1)
Input "L" voltage 2	V <sub>IL2</sub>	-0.3	-	I <sub>O_LVL</sub> x0.15	V	Hysteresis input (RESETB, CAMCKI, AUTO, MODE0, MODE1)
Output "H" voltage	V <sub>OH</sub>	I <sub>O_LVL</sub> -0.4	-	I <sub>O_LVL</sub>	V	I <sub>OH</sub> =-1.0mA(DC) (including output mode of I/O terminal)
Output "L" voltage	V <sub>OL</sub>	0.0	-	0.4	V	I <sub>OL</sub> =1.0mA(DC) (including output mode of I/O terminal)

\* I<sub>O\_LVL</sub> is a generic name of VDDIO, VDDI2C and AVDD.

#### 2. DC characteristics (DAC)

(Unless otherwise specified VDD=1.50V, VDDIO=3.3V, VDDI2C=3.3V, AVDD=3.3V, GND=0.0V, Ta=25°C)

Parameter	Symbol	Limits			Unit	Condition
		MIN.	TYP.	MAX.		
Integral Non-linearity	INL	-	±4.0	±8.0	LSB	RL=37.5Ω, RIREF=2.4kΩ, DAC resolution=10bit
Differential Non-linearity	DNL	-	±1.0	±2.0	LSB	RL=37.5Ω, RIREF=2.4kΩ, DAC resolution=10bit
Output Voltage (full scale)	VFS	1.1	1.25	1.4	V	RL=37.5Ω, RIREF=2.4kΩ, DAC resolution=10bit

●Electrical characteristics(AC characteristics)

1. Data Input Interface Timing

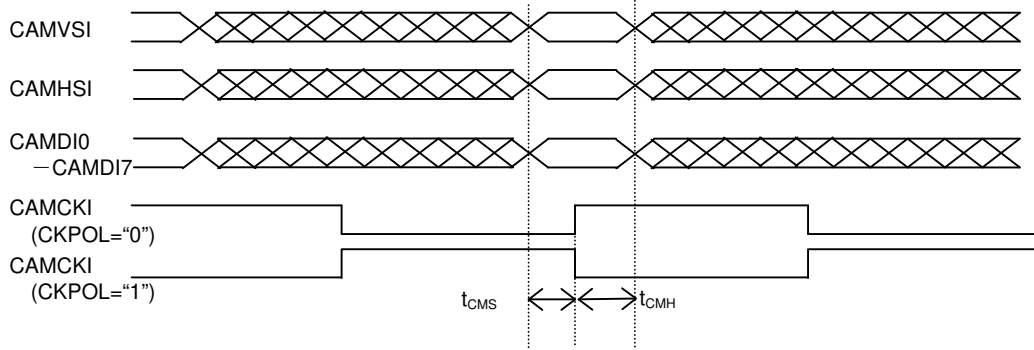


Fig.5 Data Input Interface Timing

Symbol	Description	MIN	TYP	MAX	Unit	
$t_{CAMCKI}$	CAMCKI Clock Cycle	27.8	-	-	ns	
$d_{CAMCKI}$	CAMCKI Clock Duty	45	50	55	%	
$t_{CMS}$	CAMCKI Rise / Fall Camera Setup Time	8	-	-	ns	
$t_{CMH}$	CAMCKI Rise / Fall Camera Hold Time	BU6520KV	6	-	-	ns
		BU6521KV	5	-	-	ns

\* CKPOL selects the CAMCKI polarity. (CKPOL is register at BU6520KV/BU6521KV)

2. Data Output Interface Timing

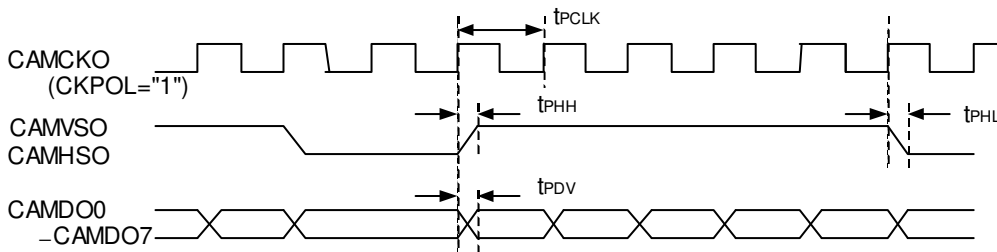


Fig.6 Data Output Interface Timing

Symbol	Description	MIN	TYP	MAX	Unit
$t_{PCLK}$	CAMCKO Clock Cycle	27.8	-	-	ns
$d_{PCLK}$	CAMCKO Clock Duty	40	50	60	%
$t_{PDV}$	Decision of CAMDO from CAMCKO	-	-	7	ns
$t_{PHL}, t_{PHH}$	Decision of CAMVSO or CAMHSO from CAMCKO	-	-	7	ns

\* This figure shows CKPOL setting is " 1 " In case of CKPOL= " 0 ", CAMVSO, CAMHSO and CAMDO0-CAMCO7 change based on CAMCKO fall edge.

3. 2-line Serial Interface Timing

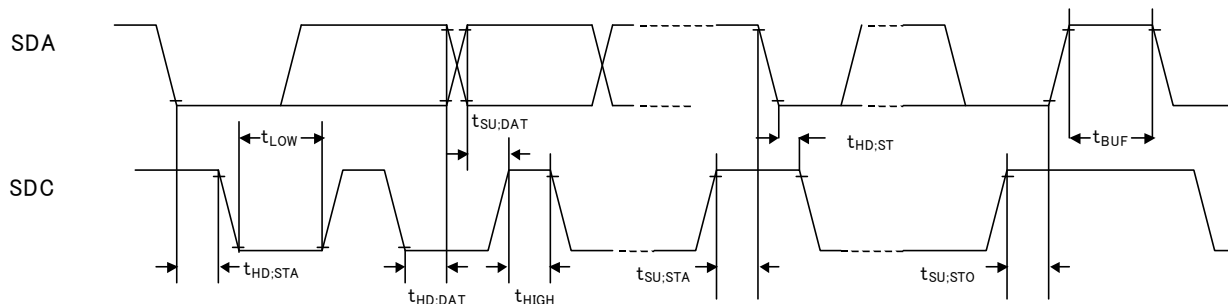


Fig.7 2-line Serial Interface Timing

Symbol	Description	MIN	TYP	MAX	Unit
$f_{SCL}$	SDC Clock Frequency	0	-	400	kHz
$t_{HD,STA}$	Hold Time (repetition) "START" conditions. The first clock pulse is generated after this period.	0.6	-	-	$\mu s$
$f_{LOW}$	The "L" period of SDC clock	1.3	-	-	$\mu s$
$t_{HIGH}$	The "H" period of SDC clock	0.6	-	-	$\mu s$
$t_{SU,STA}$	Setup Time of repetitive "START" conditions	0.6	-	-	$\mu s$
$t_{HD,DAT}$	Data Hold Time	0	-	-	$\mu s$
$t_{SU,DAT}$	Data Setup Time	100	-	-	ns
$t_{SU,STO}$	Setup Time of the "STOP" conditions	0.6	-	-	$\mu s$
$t_{BUF}$	Bus free Time between "STOP" conditions and the "START" conditions	1.3	-	-	$\mu s$

4. SPI-bus Interface Timing

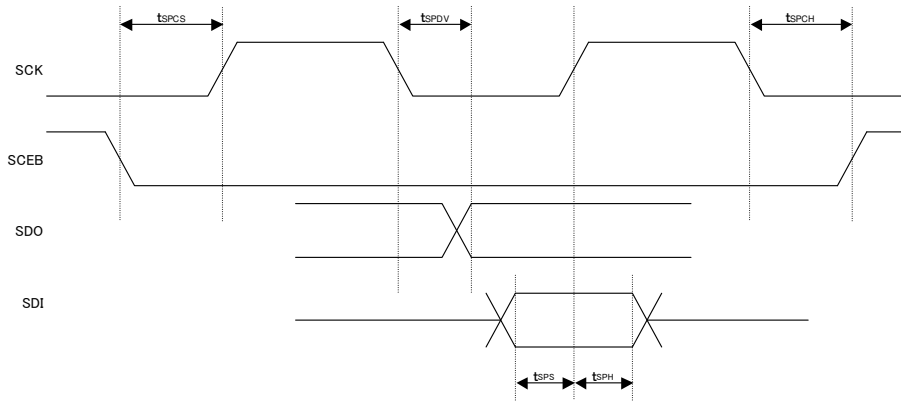


Fig.8 SPI-bus Interface Timing

Symbol	Description	MIN	TYP	MAX	Unit
t <sub>SPCLK</sub>	Clock Cycle	2	736*1	8192	t <sub>CAMCKI</sub>
d <sub>SPCLK</sub>	Clock Duty	45	50	55	%
t <sub>SPCS</sub>	SCK Rise SCEB Setup Time	4	738~1105*1	12289	t <sub>CAMCKI</sub>
t <sub>SPCH</sub>	SCEB Rise after SCK Rise Time	2	751*1	8319	t <sub>CAMCKI</sub>
t <sub>SPDV</sub>	Decision of SDO from SCK Fall	-	-	28	ns
t <sub>SPS</sub>	SCK Rise SDI Setup Time	-	-	28	ns
t <sub>SPH</sub>	SCK Rise SDI Hold Time	-	-	28	ns

\*1 Default status right after reset

When the automatic reading function with the AUTO pin is used, it becomes timing of SCEB to SCK as above. It is possible to access from the register of BU6520KV/BU6521KV to EEPROM. In that case, SCEB is controlled by the register. After the value is set to the register, the SCEB pin is changed into the logic set at once.

● Functional descriptions

- 1. Analog Composite Output Waveform
- 1.1. Output waveform in NTSC

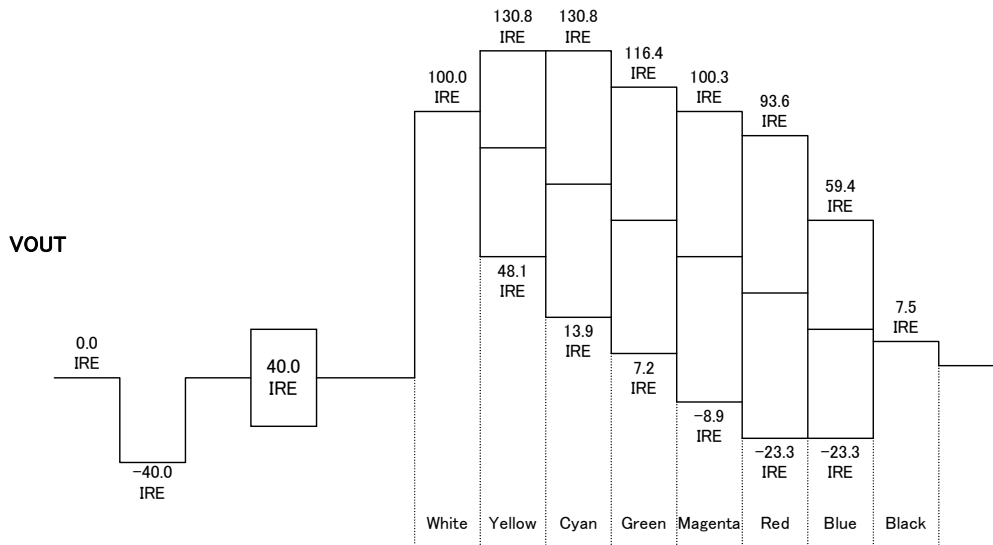


Fig.9 Color-bar corrugation in NTSC setting

- 1.2. Output waveform in PAL

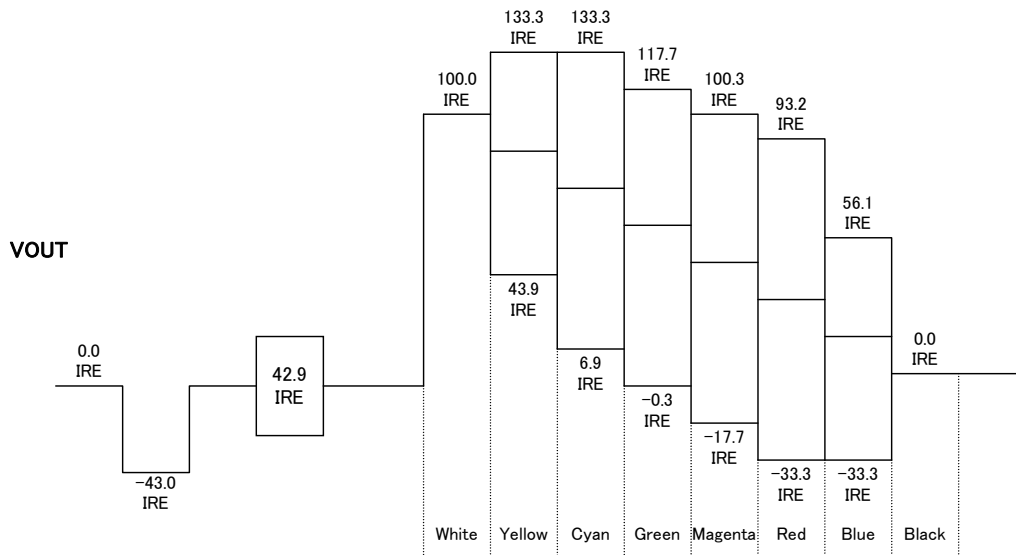


Fig.10 Color-bar corrugation in PAL setting

2. The 2 line formula serial interface format

Slave address is 70h.

The sub-address is incremented automatically when accessing it (read / write) continuously 2 times or more.

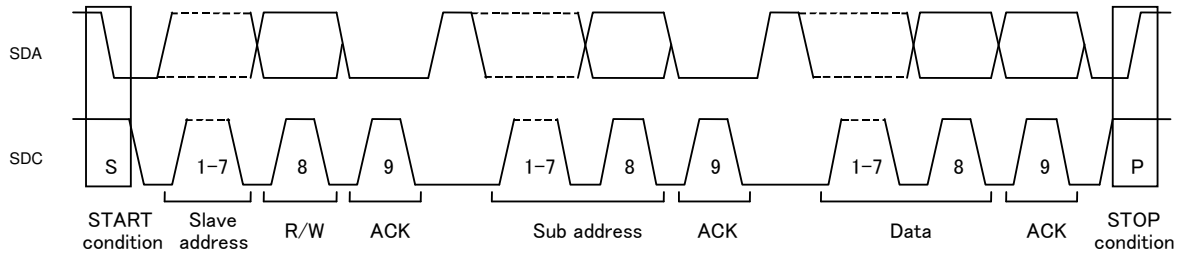


Fig.11 Waveform of date transmission part

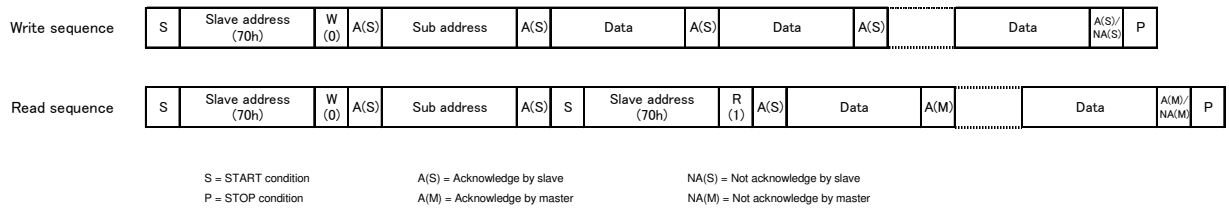


Fig.12 2-line serial interface format

3. SPI-bus format

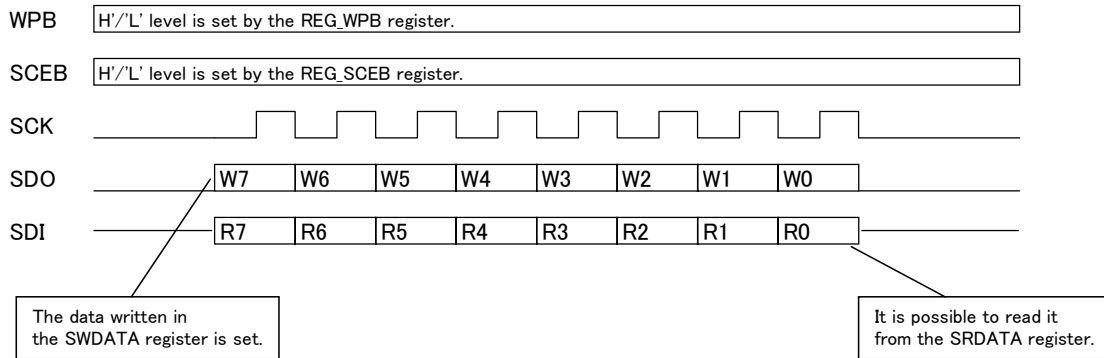


Fig.13 SPI-bus interface wave form

\* REG\_WPB, REG\_SCEB, SWDATA, and SRDATA in figure are the register names, and the each function is as follows.  
 REG\_WPB : Set WP Terminal logic. Register value is output directly.  
 REG\_SCEB : Set SCEB Terminal logic. Register value is output directly.  
 SWDATA[7:0] : Write data to EEPROM. Transfers MSB the first.  
 SRDATA[7:0] : Read data from EEPROM. Converts MSB the first.

The SCK clock frequency is as follows.

$$SCK \text{ frequency} = \text{CAMCKI frequency} \div 2^{(SPIPREDIV+1)} \div (SPIDIV+1)$$

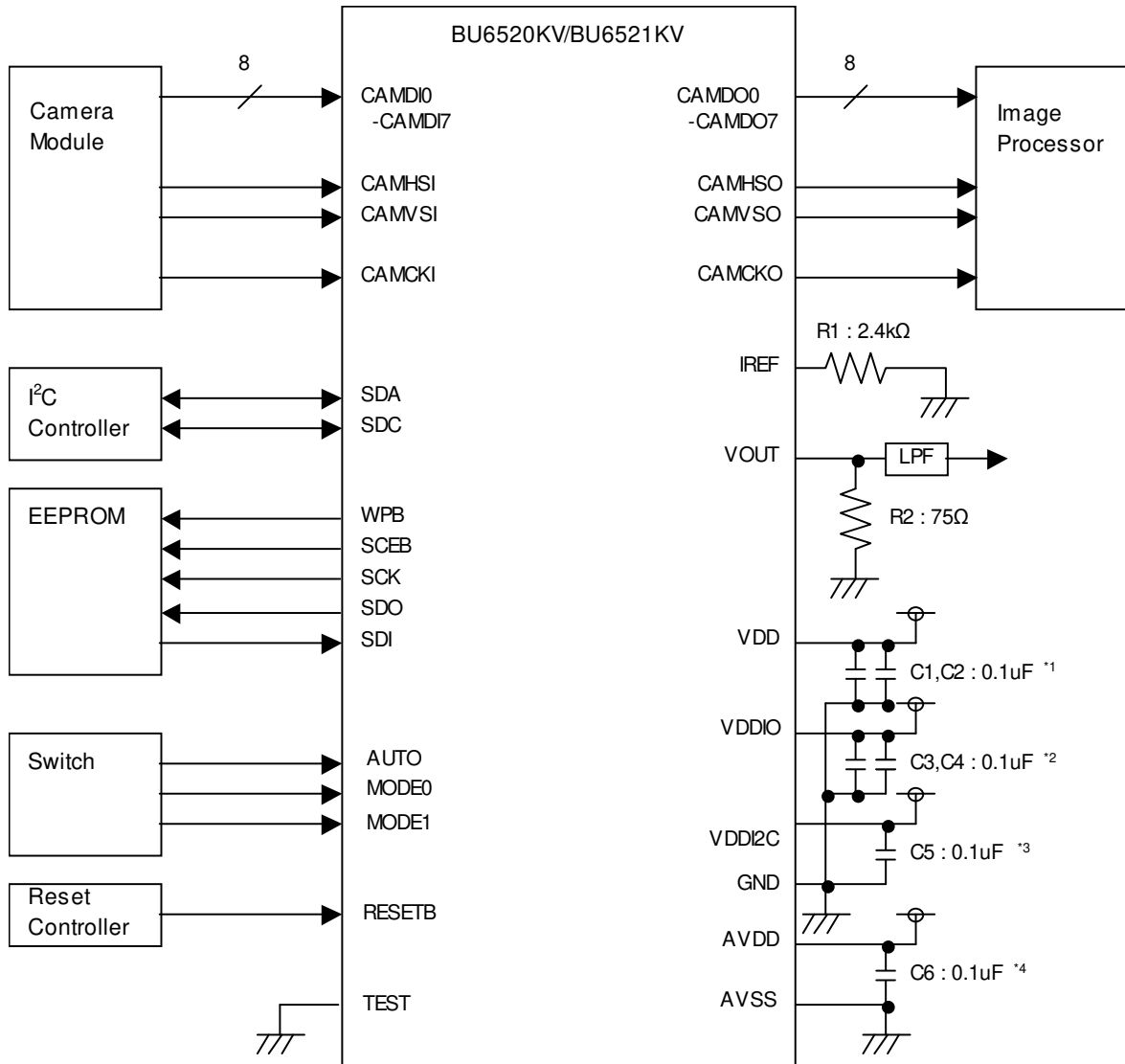
Register range : SPIPREDIV = 0 to 7, SPIDIV = 0 to 31

When CAMCKI is 27MHz, SCK becomes 3.3 kHz from 13.5 MHz.



●Application example

<When registers are controlled by both of the automatic reading from EEPROM and the I<sup>2</sup>C controller >

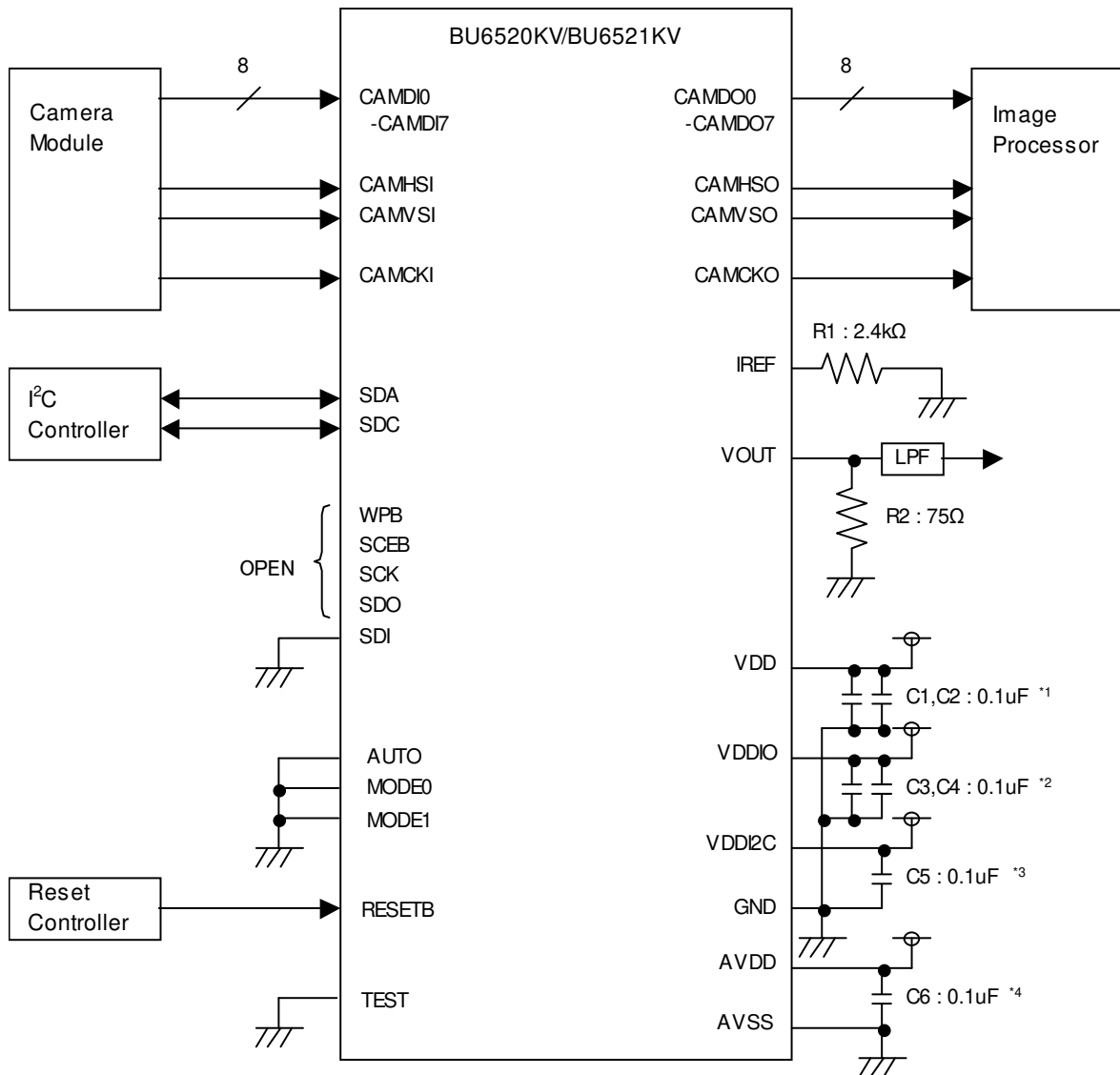


- \*1 Please arrange a capacitor each near two VDD pin.
- \*2 Please arrange a capacitor each near two VDDIO pin.
- \*3 Please arrange a capacitor near VDDI2C pin.
- \*4 Please arrange a capacitor near AVDD pin.

Fig.14 Application example 1

Fig.14 is a reference example when the system is connected, and the operation is not guaranteed.

<When registers are controlled only by the I<sup>2</sup>C controller>

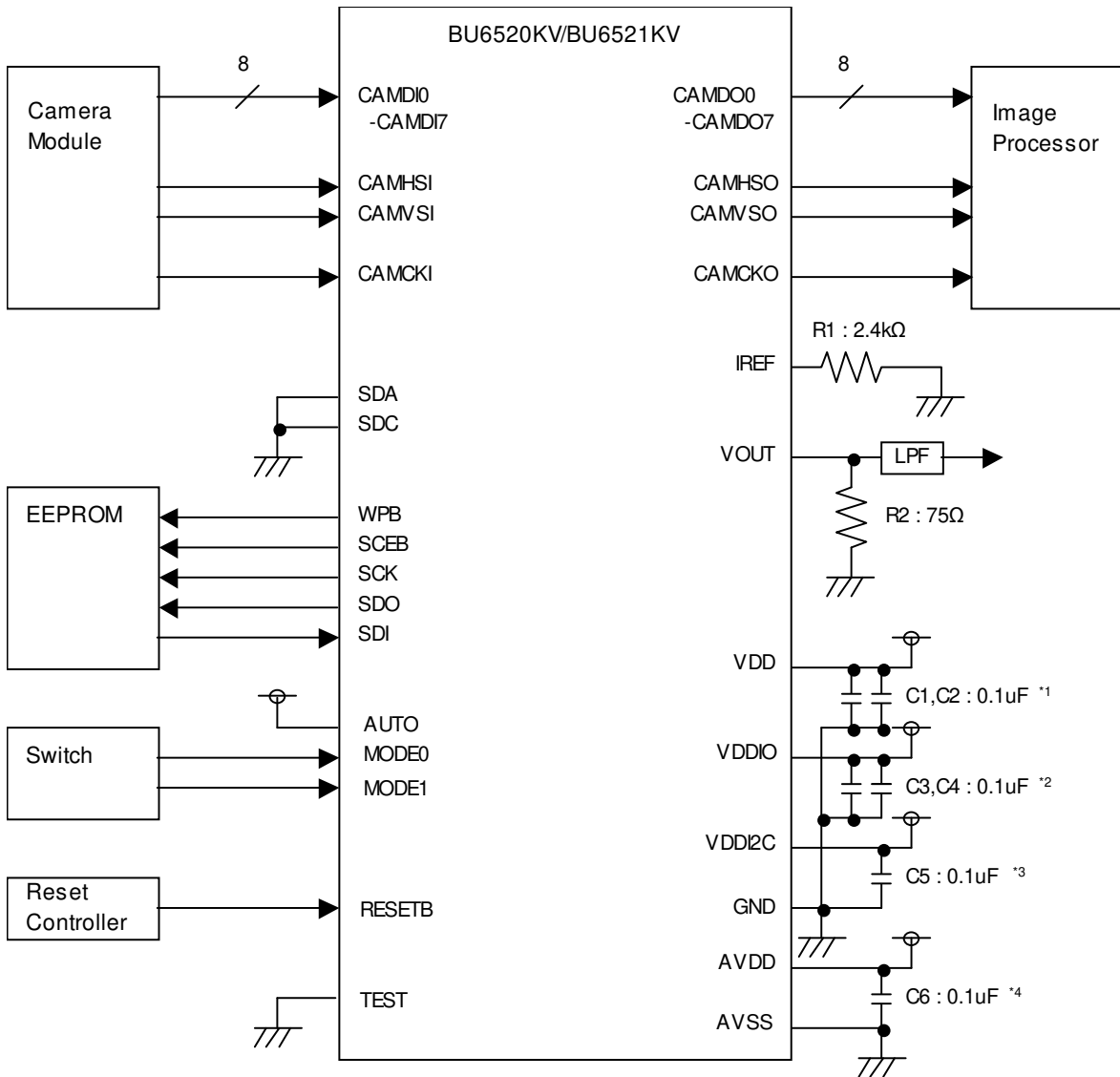


- \*1 Please arrange a capacitor each near two VDD pin.
- \*2 Please arrange a capacitor each near two VDDIO pin.
- \*3 Please arrange a capacitor near VDDI2C pin.
- \*4 Please arrange a capacitor near AVDD pin.

Fig.15 Application example 2

Fig.15 is a reference example when the system is connected, and the operation is not guaranteed.

<When registers are controlled only by the automatic reading from EEPROM >



- \*1 Please arrange a capacitor each near two VDD pin.
- \*2 Please arrange a capacitor each near two VDDIO pin.
- \*3 Please arrange a capacitor near VDDI2C pin.
- \*4 Please arrange a capacitor near AVDD pin.

Fig.16 Application example 3

Fig.16 is a reference example when the system is connected, and the operation is not guaranteed.

**● Note for use**

- (1) Absolute Maximum Ratings  
An excess in the absolute maximum ratings, such as supply voltage, temperature range of operating conditions, etc., can break down devices, thus making impossible to identify breaking mode such as a short circuit or an open circuit. If any special mode exceeding the absolute maximum ratings is assumed, consideration should be given to take physical safety measures including the use of fuses, etc.
- (2) Operating conditions  
These conditions represent a range within which characteristics can be provided approximately as expected. The electrical characteristics are guaranteed under the conditions of each parameter.
- (3) Reverse connection of power supply connector  
The reverse connection of power supply connector can break down ICs. Take protective measures against the breakdown due to the reverse connection, such as mounting an external diode between the power supply and the IC's power supply terminal.
- (4) Power supply line  
Design PCB pattern to provide low impedance for the wiring between the power supply and the GND lines.  
In this regard, for the digital block power supply and the analog block power supply, even though these power supplies has the same level of potential, separate the power supply pattern for the digital block from that for the analog block, thus suppressing the diffraction of digital noises to the analog block power supply resulting from impedance common to the wiring patterns. For the GND line, give consideration to design the patterns in a similar manner.  
Furthermore, for all power supply terminals to ICs, mount a capacitor between the power supply and the GND terminal. At the same time, in order to use an electrolytic capacitor, thoroughly check to be sure the characteristics of the capacitor to be used present no problem including the occurrence of capacity dropout at a low temperature, thus determining the constant.
- (5) GND voltage  
Make setting of the potential of the GND terminal so that it will be maintained at the minimum in any operating state. Furthermore, check to be sure no terminals are at a potential lower than the GND voltage including an actual electric transient.
- (6) Short circuit between terminals and erroneous mounting  
In order to mount ICs on a set PCB, pay thorough attention to the direction and offset of the ICs. Erroneous mounting can break down the ICs. Furthermore, if a short circuit occurs due to foreign matters entering between terminals or between the terminal and the power supply or the GND terminal, the ICs can break down.
- (7) Operation in strong electromagnetic field  
Be noted that using ICs in the strong electromagnetic field can malfunction them.
- (8) Inspection with set PCB  
On the inspection with the set PCB, if a capacitor is connected to a low-impedance IC terminal, the IC can suffer stress. Therefore, be sure to discharge from the set PCB by each process. Furthermore, in order to mount or dismount the set PCB to/from the jig for the inspection process, be sure to turn OFF the power supply and then mount the set PCB to the jig. After the completion of the inspection, be sure to turn OFF the power supply and then dismount it from the jig. In addition, for protection against static electricity, establish a ground for the assembly process and pay thorough attention to the transportation and the storage of the set PCB.
- (9) Input terminals  
In terms of the construction of IC, parasitic elements are inevitably formed in relation to potential. The operation of the parasitic element can cause interference with circuit operation, thus resulting in a malfunction and then breakdown of the input terminal. Therefore, pay thorough attention not to handle the input terminals, such as to apply to the input terminals a voltage lower than the GND respectively, so that any parasitic element will operate. Furthermore, do not apply a voltage to the input terminals when no power supply voltage is applied to the IC. In addition, even if the power supply voltage is applied, apply to the input terminals a voltage lower than the power supply voltage or within the guaranteed value of electrical characteristics.
- (10) Ground wiring pattern  
If small-signal GND and large-current GND are provided, It will be recommended to separate the large-current GND pattern from the small-signal GND pattern and establish a single ground at the reference point of the set PCB so that resistance to the wiring pattern and voltage fluctuations due to a large current will cause no fluctuations in voltages of the small-signal GND. Pay attention not to cause fluctuations in the GND wiring pattern of external parts as well.
- (11) External capacitor  
In order to use a ceramic capacitor as the external capacitor, determine the constant with consideration given to a degradation in the nominal capacitance due to DC bias and changes in the capacitance due to temperature, etc.
- (12) Rush current  
For ICs with more than one power supply, it is possible that rush current may flow instantaneously due to the internal powering sequence and delays. Therefore, give special consideration to power coupling capacitance, power wiring, width of GND wiring, and routing of wiring.

● Ordering part number

B	U
---	---

Part No.

6	5	2	0
---	---	---	---

Part No.  
6520  
6521

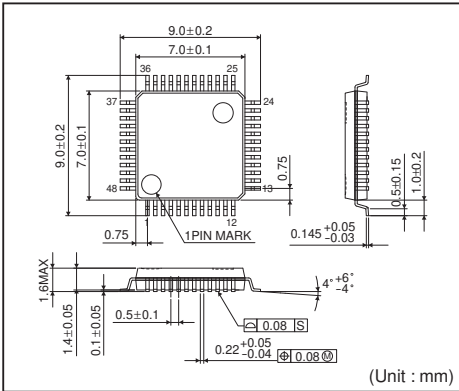
K	V
---	---

Package  
KV:VQFP48C

E	2
---	---

Packaging and forming specification  
E2: Embossed tape and reel

VQFP48C



<Tape and Reel information>

Tape	Embossed carrier tape
Quantity	1500pcs
Direction of feed	E2 (The direction is the 1pin of product is at the upper left when you hold reel on the left hand and you pull out the tape on the right hand )

Reel, 1pin, Direction of feed

\*Order quantity needs to be multiple of the minimum quantity.

## Notes

No copying or reproduction of this document, in part or in whole, is permitted without the consent of ROHM Co.,Ltd.

The content specified herein is subject to change for improvement without notice.

The content specified herein is for the purpose of introducing ROHM's products (hereinafter "Products"). If you wish to use any such Product, please be sure to refer to the specifications, which can be obtained from ROHM upon request.

Examples of application circuits, circuit constants and any other information contained herein illustrate the standard usage and operations of the Products. The peripheral conditions must be taken into account when designing circuits for mass production.

Great care was taken in ensuring the accuracy of the information specified in this document. However, should you incur any damage arising from any inaccuracy or misprint of such information, ROHM shall bear no responsibility for such damage.

The technical information specified herein is intended only to show the typical functions of and examples of application circuits for the Products. ROHM does not grant you, explicitly or implicitly, any license to use or exercise intellectual property or other rights held by ROHM and other parties. ROHM shall bear no responsibility whatsoever for any dispute arising from the use of such technical information.

The Products specified in this document are intended to be used with general-use electronic equipment or devices (such as audio visual equipment, office-automation equipment, communication devices, electronic appliances and amusement devices).

The Products specified in this document are not designed to be radiation tolerant.

While ROHM always makes efforts to enhance the quality and reliability of its Products, a Product may fail or malfunction for a variety of reasons.

Please be sure to implement in your equipment using the Products safety measures to guard against the possibility of physical injury, fire or any other damage caused in the event of the failure of any Product, such as derating, redundancy, fire control and fail-safe designs. ROHM shall bear no responsibility whatsoever for your use of any Product outside of the prescribed scope or not in accordance with the instruction manual.

The Products are not designed or manufactured to be used with any equipment, device or system which requires an extremely high level of reliability the failure or malfunction of which may result in a direct threat to human life or create a risk of human injury (such as a medical instrument, transportation equipment, aerospace machinery, nuclear-reactor controller, fuel-controller or other safety device). ROHM shall bear no responsibility in any way for use of any of the Products for the above special purposes. If a Product is intended to be used for any such special purpose, please contact a ROHM sales representative before purchasing.

If you intend to export or ship overseas any Product or technology specified herein that may be controlled under the Foreign Exchange and the Foreign Trade Law, you will be required to obtain a license or permit under the Law.



Thank you for your accessing to ROHM product informations.  
More detail product informations and catalogs are available, please contact us.

## ROHM Customer Support System

<http://www.rohm.com/contact/>