



Chipsmall Limited consists of a professional team with an average of over 10 year of expertise in the distribution of electronic components. Based in Hongkong, we have already established firm and mutual-benefit business relationships with customers from,Europe,America and south Asia,supplying obsolete and hard-to-find components to meet their specific needs.

With the principle of “Quality Parts,Customers Priority,Honest Operation,and Considerate Service”,our business mainly focus on the distribution of electronic components. Line cards we deal with include Microchip,ALPS,ROHM,Xilinx,Pulse,ON,Everlight and Freescale. Main products comprise IC,Modules,Potentiometer,IC Socket,Relay,Connector.Our parts cover such applications as commercial,industrial, and automotives areas.

We are looking forward to setting up business relationship with you and hope to provide you with the best service and solution. Let us make a better world for our industry!



## Contact us

Tel: +86-755-8981 8866 Fax: +86-755-8427 6832

Email & Skype: info@chipsmall.com Web: www.chipsmall.com

Address: A1208, Overseas Decoration Building, #122 Zhenhua RD., Futian, Shenzhen, China



# DTMF receiver for telephones

## BU8871F

The BU8871F is a DTMF receiver ICs developed for use in telephone answering machines, and converts 16 different types of DTMF signals into 4-bit binary serial data. It features a wide dynamic range, eliminating the need for an external input amplifier. Expertise from a number of companies has been incorporated into these products to enable guard time control through a host microcomputer.

●Applications

Telephone answering machines

●Features

- 1) Dynamic range of 45dB. (internal AGC)
- 2) 4-bit binary serial data output.
- 3) Guard time can be controlled through host microcontroller.
- 4) Input pins equipped with hysteresis. (ACK pin)
- 5) 4.19MHz crystal resonator can be used.

●Block diagram

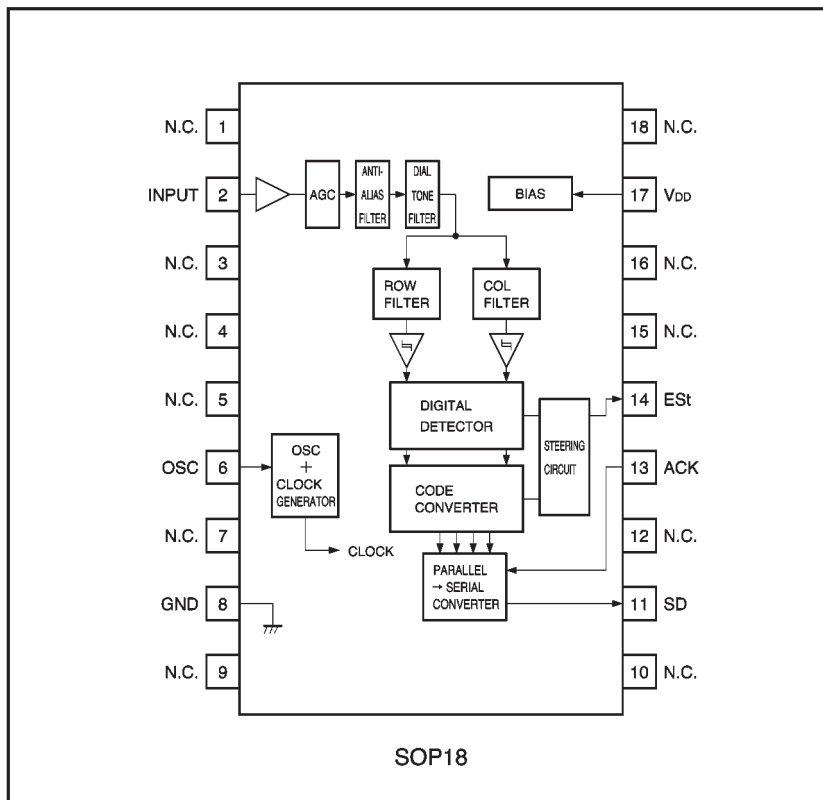

## ● Absolute maximum ratings (Ta=25°C)

Parameter	Symbol	Limits	Unit
Power supply voltage	V <sub>DD</sub>	7	V
Input voltage	V <sub>IN</sub>	GND-0.3~V <sub>DD</sub> +0.3	V
Output voltage	V <sub>OUT</sub>	GND-0.3~V <sub>DD</sub> +0.3	V
Power dissipation	P <sub>d</sub>	550*1	mW
Operating temperature	T <sub>opr</sub>	-10~+70	°C
Storage temperature	T <sub>stg</sub>	-55~+125	°C

\*1 Reduced by 5.5 mW for each increase in Ta of 1°C over 25°C.

## ● Recommended operating conditions (Ta=25°C)

Parameter	Symbol	Limits	Unit
Power supply voltage	V <sub>DD</sub>	4.75~5.25	V
Oscillation frequency	f <sub>osc</sub>	4.194304	MHz
Oscillation frequency deviation	Δf <sub>osc</sub>	-0.1~+0.1	%

## ● Pin descriptions

Pin No.	Pin name	Function
2	INPUT	This is the audio signal input pin, and should be AC coupled.
6	OSC	This is the input pin for the internal oscillator. Connect a 4.194304 MHz crystal resonator between this pin and GND, or use input from an external oscillator.
8	GND	This is the ground pin.
11	SD	This is the serial data output pin. If a series of pulses is input to the ACK pin while the EST pin is HIGH, the SD output pin outputs a 4-bit binary code corresponding to the DTMF signal shown in Table 1.
13	ACK	This is the acknowledgement pulse input pin. It is equipped with hysteresis. After the EST pin goes HIGH, the four consecutive pulses input to the ACK pin cause the 4-bit data corresponding to the DTMF signal of the SD pin output to be output. The rising edge of the first pulse is latched before the data is shifted.
14	ES <sub>t</sub>	This is the steering signal output pin. When there is a valid DTMF signal, this pin goes HIGH.
17	V <sub>DD</sub>	This is the power supply pin.
1, 3, 4, 5, 7, 9, 10, 12, 15, 16, 18	N.C.	This is the N.C. pin. It is not connected inside the IC.

● Input / output circuits

INPUT

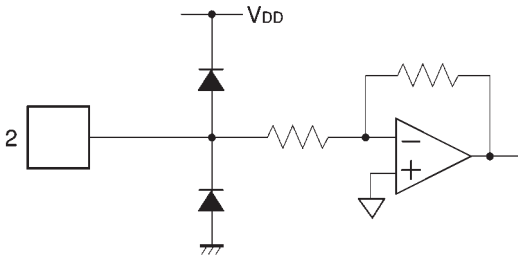

OSC

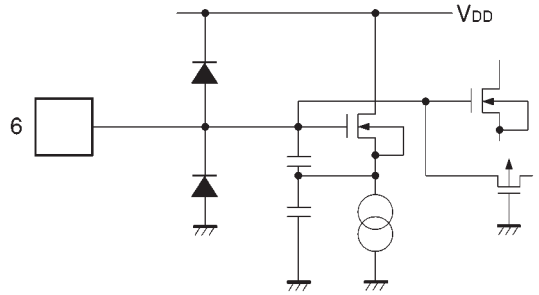

ACK

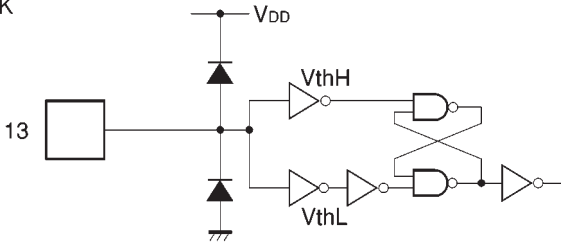

SD  
Est

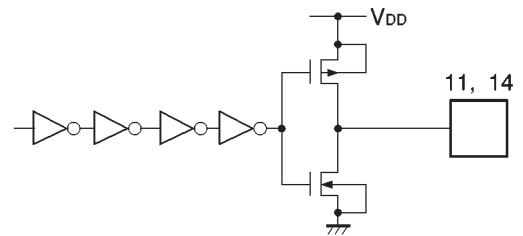

## ●Electrical characteristics

DC characteristics (unless otherwise noted, Ta=25°C, VDD=5.0V)

Parameter	Symbol	Min.	Typ.	Max.	Unit	Conditions	Measurement circuit
Supply current	I <sub>DD</sub>	1.0	2.2	3.4	mA		Fig.1
Input high level voltage	V <sub>IH</sub>	V <sub>DD</sub> -0.8	—	V <sub>DD</sub>	V	ACK pin	Fig.1
Input low level voltage	V <sub>IL</sub>	GND	—	GND+0.8	V	ACK pin	Fig.1
Input high level current	I <sub>IH</sub>	—	0.1	1.0	μA	ACK pin	Fig.1
Input low level current	I <sub>IL</sub>	—	0.1	1.0	μA	ACK pin	Fig.1
Pin 1 input impedance	Z <sub>IN</sub>	10	30	50	kΩ	v <sub>in</sub> =0dBm, fin=1kHz	Fig.1
Output saturation high level voltage	V <sub>OH</sub>	4.6	—	—	V	I <sub>OH</sub> =0.4mA*2	Fig.1
Output saturation low level voltage	V <sub>OL</sub>	—	—	0.4	V	I <sub>OL</sub> =1mA*2	Fig.1

AC characteristics (unless otherwise noted, Ta=25°C, VDD=5.0V)

Parameter	Symbol	Min.	Typ.	Max.	Unit	Conditions	v <sub>in</sub> (dBm)	Measurement circuit	
Valid input level range	VIV	-42	—	3	dBm	*3, 4, 5	—	Fig. 2	
Dual tone level difference	Positive	VTWP	—	—	6	dB	*4	-15	Fig. 2
	Negative	VTWN	—	—	6	dB	*4	-15	Fig. 2
Frequency detection range	BWA	±1.5%±2Hz	—	—	—	*5	-27	Fig. 2	
Frequency rejection range	BWR	—	—	±4	%	*5	-27	Fig. 2	
3rd tone tolerance	TTT	—	—	-16	dB	*5, 6	-27	Fig. 2	
Noise tolerance	TN	—	-12	—	dB		-27	Fig. 2	
Dial tone tolerance	TDT	—	14	7	dB	*7	-27	Fig. 2	
Signal presence detection time	tDP	5	12	20	ms		-27	Fig. 2	
Signal absence detection time	tDA	0.5	5	15	ms		-27	Fig. 2	
Data shift rate	fDS	—	—	1	MHz	ACK Duty 40%~60%	—	Fig. 2	
Output delay time	tPAD	—	70	150	ns	ACK→SD	—	Fig. 2	
Setup time	tDL	0	—	—	ns		—	Fig. 2	
Hold time	tDH	30	60	—	ns		—	Fig. 2	

\*2 Applies to Est pin and SD pin.

\*3 A DTMF signal is input, and the voltage level of the single tone component is set as VIV.

\*4 Specified for a DTMF signal with a frequency deviation at the maximum standard frequency ± 0.73%.

\*5 No difference in level between the two tones.

\*6 Composite signal consisting of DTMF signals and the third harmonics of each input.

\*7 Specified for signals of 350 Hz and 440 Hz (± 2%).

© Not designed for radiation resistance.

● Measurement circuits

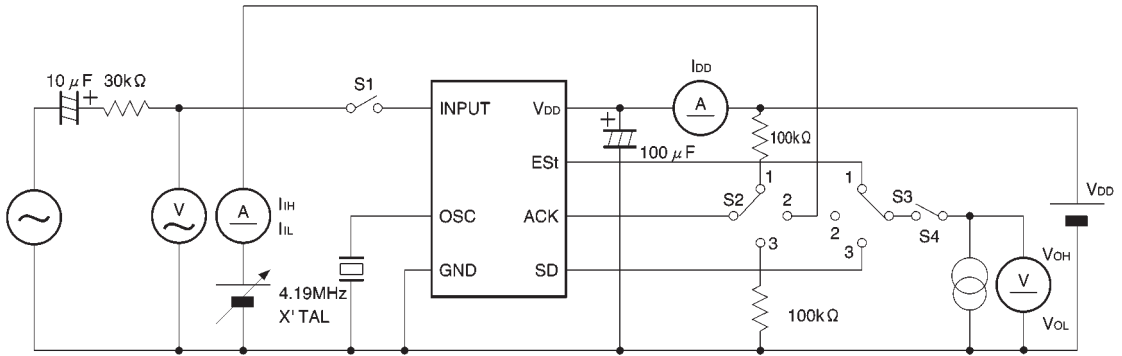

Fig. 1 DC characteristics measurement circuit

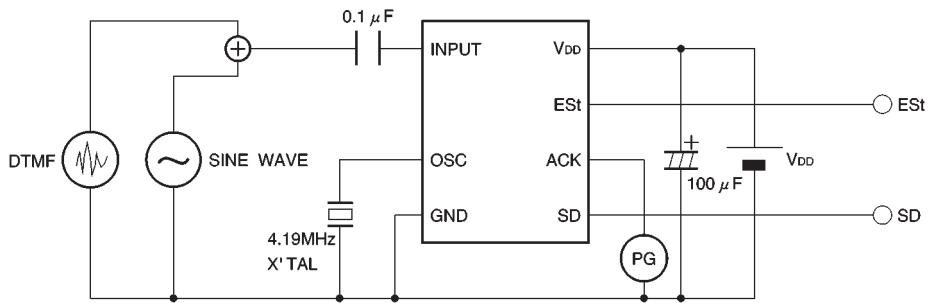

Fig. 2 AC characteristics measurement circuit



● Circuit operation

(1) An overview of operation

A DTMF signal is supplied to the INPUT pin and applied to a pair of 6th-order bandpass filters, which separate the DTMF signal into its high (COL) and low (ROW) frequencies. The separated tones are converted into square waves and fed to a digital detector. (See the block diagram.)

The digital detector checks the two tones to see if they are within the valid DTMF frequency bands. If they are, it sends a DETECT signal to the steering circuit, and sends the appropriate column and row address signals to a code converter.

The code converter encodes the received and detected DTMF signal, and outputs an ENABLE signal to the steering circuit.

Based on the DETECT and ENABLE signals, the steering circuit outputs an Early Steering (ES<sub>t</sub>) signal, which sets the ES<sub>t</sub> pin to HIGH, indicating that a valid DTMF signal has been detected.

If a series of pulses is input at the ACK pin while ES<sub>t</sub> is HIGH, a decoded DTMF signal is output to the SD pin as a binary code. (See Figure 3 for the overall timing.)

If a pulse sequence is input at the ACK pin, the data is latched at the rising edge of the first pulse by a parallel-serial converter, and at the same time, the LSB is output from the SD pin. Following this, three bits of data are output from the SD pin for each bit of each pulse in the pulse sequence input from the ACK pin. As a result, a total of four bits of data are output for the four pulses. (See Figure 4 for the ACK and SD timing.)

If the pulse sequence input to the ACK pin consists of three or fewer pulses, the next DTMF input cannot be decoded properly. Any ACK pulses in excess of four are ignored until ES<sub>t</sub> goes HIGH again.

Table 1 shows the format of serial data output from the SD pin.

(2) Overall timing chart

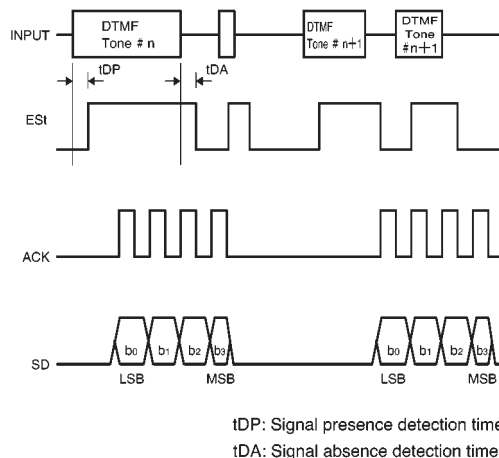

Fig. 3

(3) ACK and SD timing

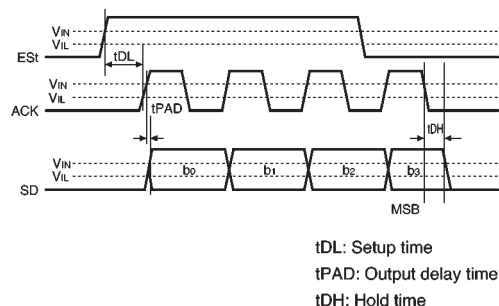

Fig. 4

●Circuit operation

(4) Serial data correspondence table

Table 1. Serial data correspondence table

ROW [Hz]	COL [Hz]	No.	b <sub>3</sub> (MSB)	b <sub>2</sub>	b <sub>1</sub>	b <sub>0</sub> (LSB)
697	1209	1	0	0	0	1
697	1336	2	0	0	1	0
697	1477	3	0	0	1	1
770	1209	4	0	1	0	0
770	1336	5	0	1	0	1
770	1477	6	0	1	1	0
852	1209	7	0	1	1	1
852	1336	8	1	0	0	0
852	1477	9	1	0	0	1
941	1336	0	1	0	1	0
941	1209	*	1	0	1	1
941	1477	#	1	1	0	0
697	1633	A	1	1	0	1
770	1633	B	1	1	1	0
852	1633	C	1	1	1	1
941	1633	D	0	0	0	0

0= "L" level, 1= "H" level

●Application example

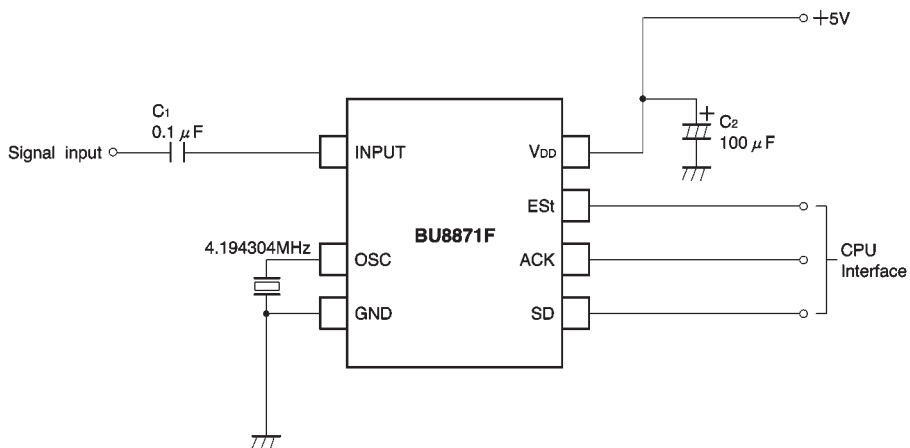

Fig. 5



● Selecting attached components

(1) Power supply components

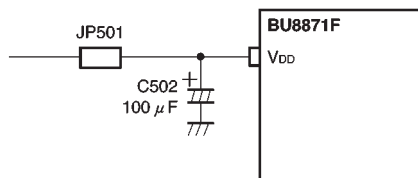

Fig. 6 Power supply circuit

C502 : This is the  $V_{DD}$  bypass capacitor, and is normally  $100\mu\text{F}$ . The maximum recommended operating power supply voltage is  $5.25\text{V}$ , so a voltage withstand value of  $6.3\text{V}$  is sufficient.

JP501 : This is normally shorted. To test the current consumption of the IC, insert a DC ammeter in place of JP501.

(2) Oscillation components

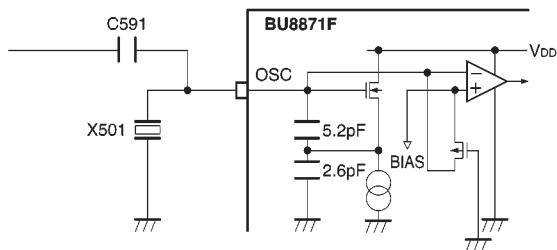

Fig. 7 Oscillation circuit

X501 : Use a crystal or ceramic resonator with an oscillation frequency of  $4.194304\text{MHz}$ . If using a ceramic resonator, there may be problems with the precision of the oscillation frequency, so please consult the manufacturer of the resonator to make sure problems will not occur.

C591 : If you are using the X501 dedicated resonator designed for DTMF receivers, capacitor C591 should be left open.

If you are injecting an external clock, X501 should be omitted and DC blocking capacitor C591 used in its place. Typically, this capacitor should be  $47\text{nF}$ .

(3) DTMF input

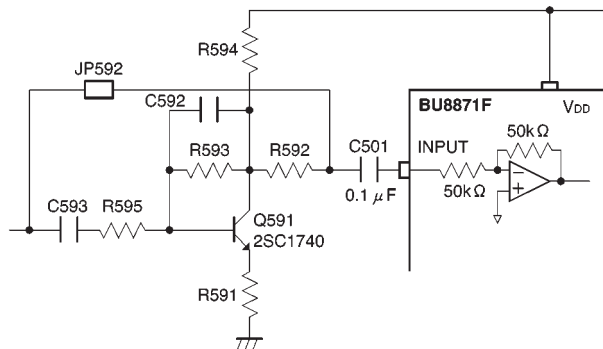

Fig. 8 DTMF input circuit

C501 : This is the DC blocking capacitor. Select a capacitor that will pass DTMF signals (greater than  $697\text{Hz}$ ) without significantly attenuating the signals.

JP592 : If DTMF signals are being input directly, both ends should be shorted.

Q591  
R591 ~ R595  
C592, C593 } Use these to increase the sensitivity of the DTMF receiver.

(4) ESt output

The ESt guard time is determined by the CPU of the host computer, but to reduce the load on the host computer, the guard time can be set using an external circuit, as shown below.

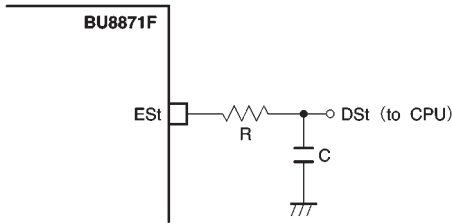

Fig. 9 Guard time setting circuit

The relation between a momentary falter in the ESt guard time ( $t_{GL}$ ), a momentary HIGH level in the ESt guard time ( $t_{GH}$ ), and the time constant is shown below. Figure 10 shows a timing diagram for guard times.

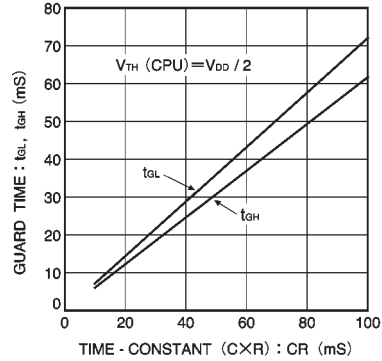

Fig. 10 Guard time vs. time constant ( $C \times R$ )

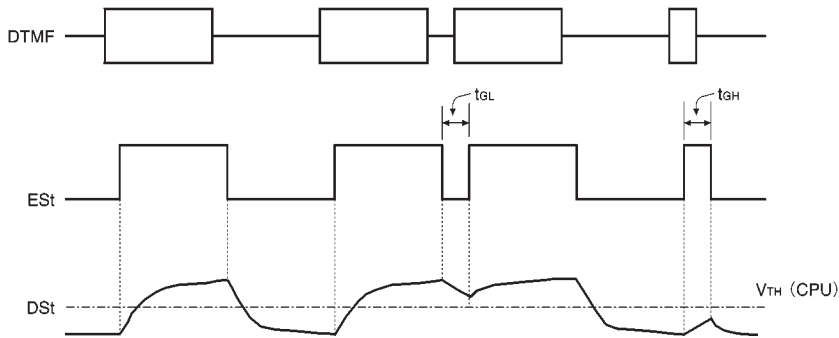

Fig. 11 Timing indicating guard times

● Operation notes

- Oscillation

Oscillation frequency precision can be a problem with ceramic resonators. Before including a ceramic resonator in your design, please consult the resonator manufacturer to make sure this will not be a problem.

Also, if an external clock is being injected, a DC blocking capacitor must be inserted. Select a capacitor that will neither attenuate the frequency components or put an excessive load on the drive side.

This LSI is not equipped with the power-on reset function. Also, since the internal circuit (flip-flop circuit) becomes unstable at the rising edge of the power supply, the internal circuit is initialized as shown below by the first DTMF sequence received after the rising edge of the power supply. Therefore, input four dummy ACK pulses before the DTMF reception.

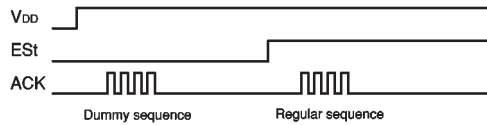

●Electrical characteristic curves

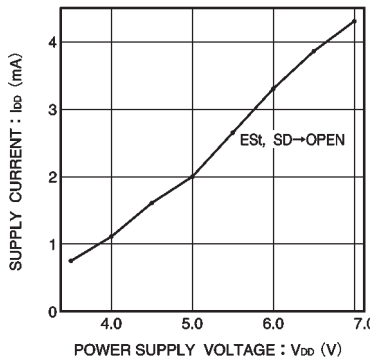

Fig. 12 Supply current vs. power supply voltage

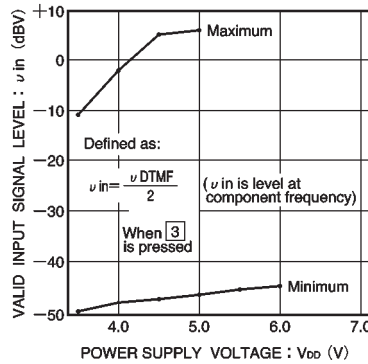

Fig. 13 Valid input level range vs. power supply voltage

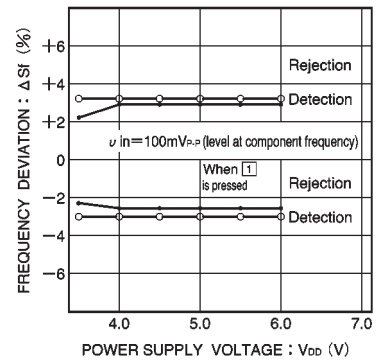

Fig. 14 Frequency detection/rejection ranges vs. power supply voltage

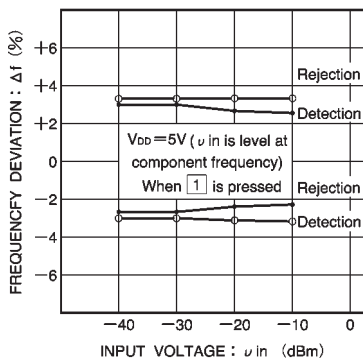

Fig. 15 Frequency detection/rejection ranges vs. input voltage

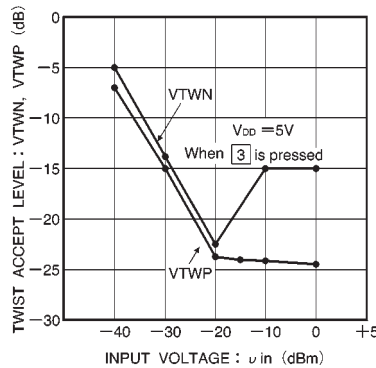

Fig. 16 2-frequency level vs. input voltage

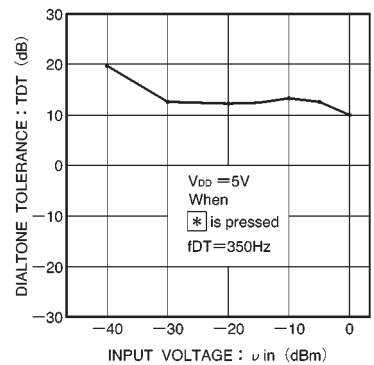

Fig. 17 Dial tone tolerance range vs. input voltage

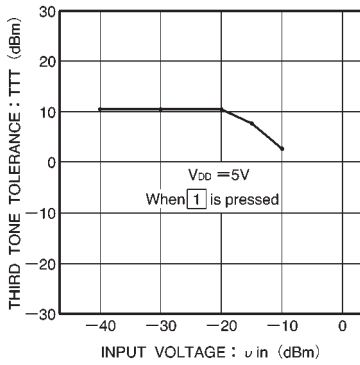

Fig. 18 Third tone tolerance range vs. input voltage

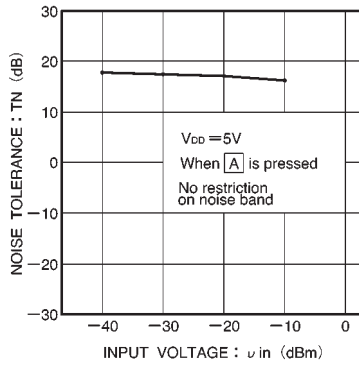
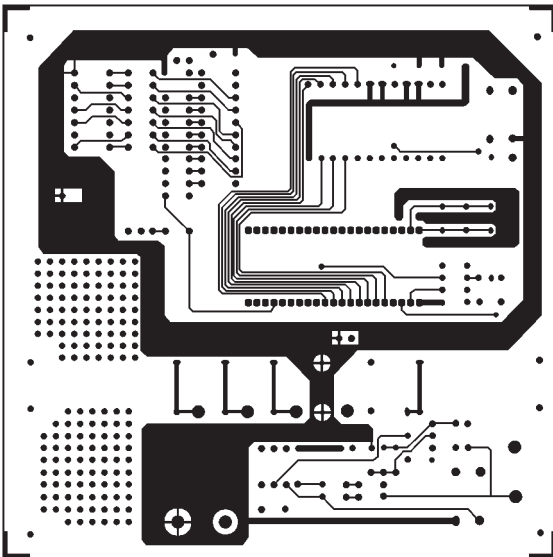

Fig. 19 Noise tolerance range vs. input voltage

● Application board patterns

(1) Pattern (soldering surface)



The BU8874 application board (AB-8874) can be used.

(2) Pattern (silk screening)

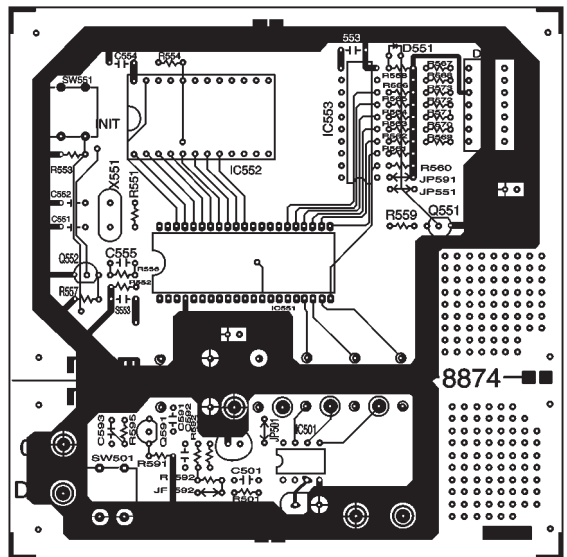

The BU8874 application board (AB-8874) can be used.

● External dimensions (Units: mm)

