



Chipsmall Limited consists of a professional team with an average of over 10 year of expertise in the distribution of electronic components. Based in Hongkong, we have already established firm and mutual-benefit business relationships with customers from,Europe,America and south Asia,supplying obsolete and hard-to-find components to meet their specific needs.

With the principle of “Quality Parts,Customers Priority,Honest Operation,and Considerate Service”,our business mainly focus on the distribution of electronic components. Line cards we deal with include Microchip,ALPS,ROHM,Xilinx,Pulse,ON,Everlight and Freescale. Main products comprise IC,Modules,Potentiometer,IC Socket,Relay,Connector.Our parts cover such applications as commercial,industrial, and automotives areas.

We are looking forward to setting up business relationship with you and hope to provide you with the best service and solution. Let us make a better world for our industry!



Contact us

Tel: +86-755-8981 8866 Fax: +86-755-8427 6832

Email & Skype: info@chipsmall.com Web: www.chipsmall.com

Address: A1208, Overseas Decoration Building, #122 Zhenhua RD., Futian, Shenzhen, China



Structure Silicon monolithic integrated circuit
Product Name PCM CODEC IC for cellular phone

Product No. **BU8920GU**

Physical dimensions Figure1 (VCSP85H2)

- Features
- 16bit Linear · μ /A-Law codec
 - Built-in PLL circuit for system clock generation
 - Support for below frequency about PCM data transmission clock.
 - μ /A-Law 64kHz - 2048 kHz
 - Linear 128 kHz -2048 kHz
 - Built-in Output amplifier for line drives (600 Ω)
 - Power down control using NRST pin

○ Absolute Maximum Ratings

Parameter	Symbol	Rating	Unit
Digital supply voltage	DVDD	-0.3~4.5	V
Analog supply voltage	AVDD	-0.3~4.5	V
Input voltage for digital terminal	V _{TD}	DVSS-0.3~4.5	V
Input voltage for analog terminal	V _{TA}	AVSS-0.3~AVDD+0.3	V
Input current	I _{IN}	-10~+10	mA
Power dissipation *1	P _d	250	mW
Storage temperature range	T _{stg}	-55~125	°C

(*1) Note: Reduce to 2.5mW/°C when Ta = 25°C or above

○ Recommended Operating Power Supply Voltage and temperature Range

Parameter	Symbol	Rating			Unit
		Min	Typ	Max	
Digital supply voltage	DVDD	1.65	1.80	1.95	V
Analog supply voltage	AVDD	2.70	2.80	3.10	V
Operating temperature range	T _{opr}	-30	-	85	°C

This product is not designed to protect itself against radioactive rays.

○ Electrical Characteristics

Unless otherwise noted, Ta = 25°C, AVDD=2.8, DVDD=1.8V, FSYNC=8kHz, DCLK=256kHz.

Parameter	Symbol	Specified Value			Unit	Condition
		Min	Typ	Max		
Current consumption						
Standby current consumption	IDD1	-	0.1	3.0	uA	NRST=DVSS and FSYNC,DCLK=DVSS
Full Operation	IDD2	-	2.5	3.8	mA	NRST,BST=DVDD, No input signal
DC Characteristics						
Digital H level input voltage	VIH	DVDDx0.75	-	4.5	V	
Digital L level input voltage	VIL	-0.3	-	DVDDx0.25	V	
Digital H level input current	I _{IH}	-	-	1	uA	VIH=DVDD
Digital L level input current	I _{IL}	-	-	-1	uA	VIL=DVSS
Digital H level output voltage	VOH	DVDDx0.8	-	DVDD	V	IOH= -1mA
Digital L level output voltage	VOL	0	-	DVDDx0.2	V	IOL= 1mA

Unless otherwise noted, Ta=25°C,AVDD=2.7~3.1V,DVDD=1.65~1.95V,FSYNC=8kHz,DCLK=256kHz,and linear mode.

Parameter	symbol	Condition	Specified Value			Unit	
			Min	Typ	Max		
Transmit signal-to-distortion ratio (AUX1IN→PCMOUT)	S _{DT}	1020Hz * 2, * 3	0dBm0	45	-	-	dB
			-30dBm0	35	-	-	
			-40dBm0	29	-	-	
			-45dBm0	24	-	-	
Receive signal-to-distortion ratio (PCMIN→AUDOUT)	S _{DR}	1020Hz * 2	0dBm0	45	-	-	dB
			-30dBm0	35	-	-	
			-40dBm0	29	-	-	
			-45dBm0	24	-	-	
Transmit Gain Tracking (AUX1IN→PCMOUT)	G _{TX}	1020Hz, Reference level=-10dBm0 * 2, * 3	+3.0~0.5dBm0	-3.0	-	3.0	dB
			+0.5~-40dBm0	-0.3	-	0.3	
			-40~-50dBm0	-0.6	-	0.6	
			-50~-55dBm0	-1.6	-	1.6	
Receive Gain Tracking (PCMIN→AUDOUT)	G _{RX}	1020Hz, Reference level=-10dBm0, * 2	+3.0~-40dBm0	-0.3	-	0.3	dB
			-40~-50dBm0	-0.6	-	0.6	
			-50~-55dBm0	-1.6	-	1.6	
Transmit reference level	V _{ITX1}	1020Hz, 0dBm0 * 2	AUX1IN→PCMOUT	0.375	0.500	0.667	Vrms
Receive reference level	V _{ORX}	1020Hz, 0dBm0 * 2	PCMIN→AUDOUT	0.400	0.475	0.564	Vrms
Transmit Gain Loss relative to Frequency (AUX1IN→PCMOUT)	G _{RTX}	1020Hz	0.06kHz	24	-	-	dB
			0.2kHz	0	-	2.5	
			0.3~0.4kHz	-0.3	-	0.5	
			0.4~3.0kHz	-0.3	-	0.3	
			3.4kHz	-0.3	-	0.9	
			3.6kHz	0	-	-	
Receive Gain Loss relative to Frequency (PCMIN→AUDOUT)	G _{RXX}	1020Hz	0.06kHz	24	-	-	dB
			0.2kHz	0	-	2.5	
			0.3~2.8kHz	-0.3	-	0.3	
			2.8~3.0kHz	-0.3	-	0.5	
			3.4kHz	-0.3	-	0.9	
			3.6kHz	0	-	-	
Transmit noise level	V _{NTX}	AUX1IN= AGND level. * 2		-	-	-76	dBV
Receive noise level	V _{NRX}	PCMIN="L". Using A-Weight filter.		-	-	-85	dBV

* 2 Using C-MESSAGE filter

* 3 Specified that 0dBm0 is 0.5Vrms

○ Physical dimensions (Figure1)

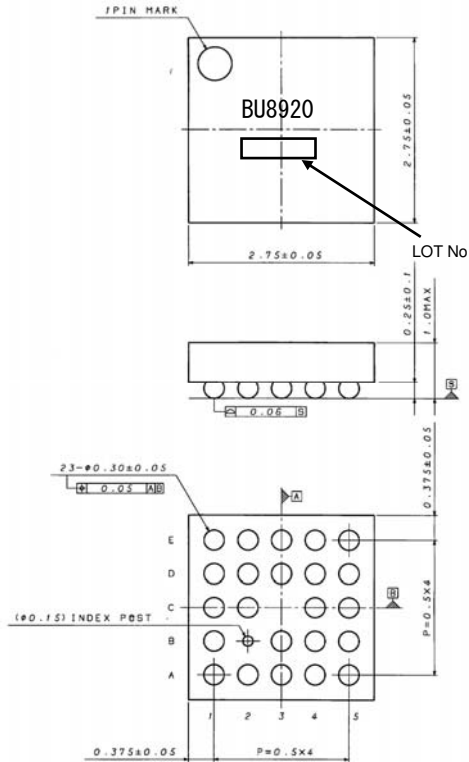

VCSP85H2(23Balls) (Unit: mm)

○ Ball assignment

Ball No	Ball name	Ball No	Ball name
A1	AVSS	C5	PCMSEL
A2	AUDOUT	D1	FRM2
A3	AVDD	D2	NRST
A4	BGFLT	D3	DVDD
A5	NC	D4	PCMIN
B1	AUX1IN	D5	DCLK
B3	PLLCAP	E1	TEST
B4	AGND	E2	DSEL
B5	VREF	E3	BST
C1	FRM1	E4	DVSS
C2	NC	E5	PCMOUT
C4	FSYNC		

Power down control using only NRST.

NRST = L : Power down mode

NRST = H : Active mode

NC : This ball is not connected with internal.

○ Block diagram (Figure2)

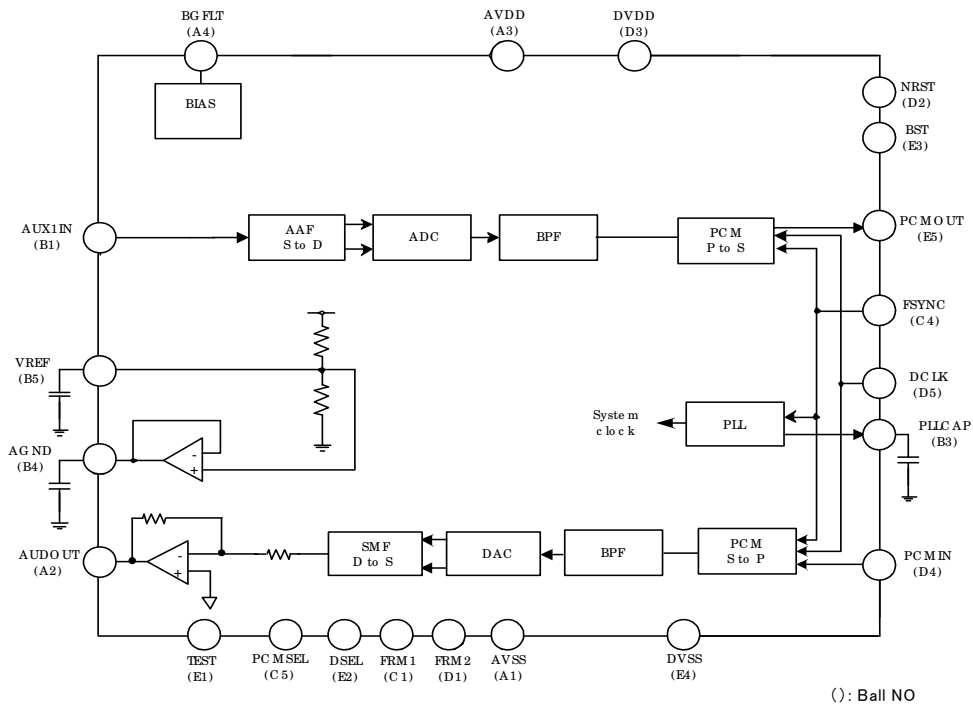

(): Ball NO

○ Cautions on use

(1) Absolute Maximum Ratings

An excess in the absolute maximum ratings, such as supply voltage, temperature range of operating conditions, etc., can break down devices, thus making impossible to identify breaking mode such as a short circuit or an open circuit. If any special mode exceeding the absolute maximum ratings is assumed, consideration should be given to take physical safety measures including the use of fuses, etc.

(2) Operating conditions

These conditions represent a range within which characteristics can be provided approximately as expected. The electrical characteristics are guaranteed under the conditions of each parameter.

(3) Reverse connection of power supply connector

The reverse connection of power supply connector can break down ICs. Take protective measures against the breakdown due to the reverse connection, such as mounting an external diode between the power supply and the IC's power supply terminal.

(4) Power supply line

Design PCB pattern to provide low impedance for the wiring between the power supply and the GND lines. In this regard, for the digital block power supply and the analog block power supply, even though these power supplies have the same level of potential, separate the power supply pattern for the digital block from that for the analog block, thus suppressing the diffraction of digital noises to the analog block power supply resulting from impedance common to the wiring patterns. For the GND line, give consideration to design the patterns in a similar manner.

Furthermore, for all power supply terminals to ICs, mount a capacitor between the power supply and the GND terminal. At the same time, in order to use an electrolytic capacitor, thoroughly check to be sure the characteristics of the capacitor to be used present no problem including the occurrence of capacity dropout at a low temperature, thus determining the constant.

(5) GND voltage

Make setting of the potential of the GND terminal so that it will be maintained at the minimum in any operating state. Furthermore, check to be sure no terminals are at a potential lower than the GND voltage including an actual electric transient.

(6) Short circuit between terminals and erroneous mounting

In order to mount ICs on a set PCB, pay thorough attention to the direction and offset of the ICs. Erroneous mounting can break down the ICs. Furthermore, if a short circuit occurs due to foreign matters entering between terminals or between the terminal and the power supply or the GND terminal, the ICs can break down.

(7) Operation in strong electromagnetic field

Be noted that using ICs in the strong electromagnetic field can malfunction them.

(8) Inspection with set PCB

On the inspection with the set PCB, if a capacitor is connected to a low-impedance IC terminal, the IC can suffer stress. Therefore, be sure to discharge from the set PCB by each process. Furthermore, in order to mount or dismount the set PCB to/from the jig for the inspection process, be sure to turn OFF the power supply and then mount the set PCB to the jig. After the completion of the inspection, be sure to turn OFF the power supply and then dismount it from the jig. In addition, for protection against static electricity, establish a ground for the assembly process and pay thorough attention to the transportation and the storage of the set PCB.

(9) Input terminals

In terms of the construction of IC, parasitic elements are inevitably formed in relation to potential. The operation of the parasitic element can cause interference with circuit operation, thus resulting in a malfunction and then breakdown of the input terminal. Therefore, pay thorough attention not to handle the input terminals, such as to apply to the input terminals a voltage lower than the GND respectively, so that any parasitic element will operate. Furthermore, do not apply a voltage to the input terminals when no power supply voltage is applied to the IC. In addition, even if the power supply voltage is applied, apply to the input terminals a voltage lower than the power supply voltage or within the guaranteed value of electrical characteristics.

(10) Ground wiring pattern

If small-signal GND and large-current GND are provided, it will be recommended to separate the large-current GND pattern from the small-signal GND pattern and establish a single ground at the reference point of the set PCB so that resistance to the wiring pattern and voltage fluctuations due to a large current will cause no fluctuations in voltages of the small-signal GND. Pay attention not to cause fluctuations in the GND wiring pattern of external parts as well.

(11) External capacitor

In order to use a ceramic capacitor as the external capacitor, determine the constant with consideration given to a degradation in the nominal capacitance due to DC bias and changes in the capacitance due to temperature, etc.

(12) Others

In case of use this LSI, please peruse some other detail documents, we called , Technical note, Functional description, Application note.

Notes

No copying or reproduction of this document, in part or in whole, is permitted without the consent of ROHM Co.,Ltd.

The content specified herein is subject to change for improvement without notice.

The content specified herein is for the purpose of introducing ROHM's products (hereinafter "Products"). If you wish to use any such Product, please be sure to refer to the specifications, which can be obtained from ROHM upon request.

Examples of application circuits, circuit constants and any other information contained herein illustrate the standard usage and operations of the Products. The peripheral conditions must be taken into account when designing circuits for mass production.

Great care was taken in ensuring the accuracy of the information specified in this document. However, should you incur any damage arising from any inaccuracy or misprint of such information, ROHM shall bear no responsibility for such damage.

The technical information specified herein is intended only to show the typical functions of and examples of application circuits for the Products. ROHM does not grant you, explicitly or implicitly, any license to use or exercise intellectual property or other rights held by ROHM and other parties. ROHM shall bear no responsibility whatsoever for any dispute arising from the use of such technical information.

The Products specified in this document are intended to be used with general-use electronic equipment or devices (such as audio visual equipment, office-automation equipment, communication devices, electronic appliances and amusement devices).

The Products specified in this document are not designed to be radiation tolerant.

While ROHM always makes efforts to enhance the quality and reliability of its Products, a Product may fail or malfunction for a variety of reasons.

Please be sure to implement in your equipment using the Products safety measures to guard against the possibility of physical injury, fire or any other damage caused in the event of the failure of any Product, such as derating, redundancy, fire control and fail-safe designs. ROHM shall bear no responsibility whatsoever for your use of any Product outside of the prescribed scope or not in accordance with the instruction manual.

The Products are not designed or manufactured to be used with any equipment, device or system which requires an extremely high level of reliability the failure or malfunction of which may result in a direct threat to human life or create a risk of human injury (such as a medical instrument, transportation equipment, aerospace machinery, nuclear-reactor controller, fuel-controller or other safety device). ROHM shall bear no responsibility in any way for use of any of the Products for the above special purposes. If a Product is intended to be used for any such special purpose, please contact a ROHM sales representative before purchasing.

If you intend to export or ship overseas any Product or technology specified herein that may be controlled under the Foreign Exchange and the Foreign Trade Law, you will be required to obtain a license or permit under the Law.



Thank you for your accessing to ROHM product informations.
More detail product informations and catalogs are available, please contact us.

ROHM Customer Support System

<http://www.rohm.com/contact/>