



Chipsmall Limited consists of a professional team with an average of over 10 year of expertise in the distribution of electronic components. Based in Hongkong, we have already established firm and mutual-benefit business relationships with customers from,Europe,America and south Asia,supplying obsolete and hard-to-find components to meet their specific needs.

With the principle of “Quality Parts,Customers Priority,Honest Operation,and Considerate Service”,our business mainly focus on the distribution of electronic components. Line cards we deal with include Microchip,ALPS,ROHM,Xilinx,Pulse,ON,Everlight and Freescale. Main products comprise IC,Modules,Potentiometer,IC Socket,Relay,Connector.Our parts cover such applications as commercial,industrial, and automotives areas.

We are looking forward to setting up business relationship with you and hope to provide you with the best service and solution. Let us make a better world for our industry!



Contact us

Tel: +86-755-8981 8866 Fax: +86-755-8427 6832

Email & Skype: info@chipsmall.com Web: www.chipsmall.com

Address: A1208, Overseas Decoration Building, #122 Zhenhua RD., Futian, Shenzhen, China



Digital Sound Processors for FPD TVs

28bit Audio DSP with Built-in 2ch ADC, 6ch DAC and ASRC



BD9406KS2

No.12083EAT01

●General Description

This LSI is the digital sound processor which made the use digital signal processing for FPD TVs. DSP of ROHM original is used for the TV sound processor unit, and it excels in cost performance. The asynchronous sampling rate converter is built in the digital input one line. The audio AD converter is built in the analog input one line. The audio DA converters are built in the output three lines.

●Features

- Digital Signal Processor unit
 - Word length: 28bit (Data RAM)
 - The fastest machine Cycle: 40.7ns (512fs, fs=48kHz)
 - Multiplier: 28x24 → 52 bit
 - Adder: 28+28 → 28bit
 - Data RAM: 256x28bit
 - Coefficient RAM: 128x24bit
 - Sampling Frequency: fs=48kHz
 - Master Clock: 512fs (24.576Mhz, fs=48kHz)
- Digital Signal Input (Stereo 4 lines): 16/20/24bit (I²S, Left-Justified, Right-Justified)
- Digital Signal Output (Stereo 4 lines): 16/20/24bit (I²S, Left-Justified, Right-Justified, S/PDIF)
- Asynchronous Sampling Rate Converter (Stereo 1 line): 32kHz/44.1kHz → 48kHz
- Audio ADC: Stereo Input 1 line
 - 20bit 64 x Over-sampling sigma delta ADC
 - S/N: 90dB
 - THD+N: 0.02% (Sine-wave 1kHz, -0.5dB)
 - Digital HPF (fc=1Hz)
- Audio DAC: Stereo Output 2 lines
 - 24bit 8x Over-sampling digital filter + 1bit sigma delta DAC
 - S/N: 96dB
 - THD+N: 0.005% (Sine-wave 1kHz, 0dB)
- Audio 16bit DAC: Stereo Output 1 line
 - 24bit 8x Over-sampling digital filter + Audio 16bit DAC
 - S/N: 90dB
 - THD+N: 0.03% (Sine-wave 1kHz, 0dB)
- The sound signal processing function for FPD TVs
 - Pre-scaler, Channel Mixer, Pseudo Stereo, Surround, P²Bass, SAS, 12-band parametric EQ, Master Volume, L/R Balance, Compression, Post-scaler, Output Signal Clipper
 - (P²Bass and SAS are ROHM's own sound effect functions.)

●Applications

Flat Panel TVs (LCD, Plasma)

●Absolute Maximum Ratings (Ta=25°C)

Item	Symbol	Rating	Unit
Power Supply Voltage	V _{DD}	4.5	V
Power Dissipation	P _d	950 (※1)	mW
Operating Temperature Range	T _{opr}	-40~+85	°C
Storage Temperature Range	T _{stg}	-55~+125	°C

*1 Use of this processor at Ta=25°C and over is subject to reduction of 9.5mW per 1 .

*2Operation is not guaranteed.

●Recommendation Operating range (Ta=-40~+85°C)

Item	Symbol	Rating	Unit
Power Supply Voltage	V _{DD}	3.0~3.6	V

*1This product is not designed for protection against radioactive rays.

●Electrical Characteristics (Digital system)

V_{DD}=3.3V (Unless otherwise specified Ta=25°C)

Item	Symbol	Limit			Unit	Conditions	Relevant Pins	
		Min.	Typ.	Max.				
Input Voltage	H-level Voltage	V _{IH}	2.3	-	-	V	*1	
	L-level Voltage	V _{IL}	-	-	1.0	V	*1	
Hysteresis Input Voltage	H-level Voltage	V _{IH}	2.5	-	-	V	*2,3,4	
	L-level Voltage	V _{IL}	-	-	0.8	V	*2,3,4	
Input Current	I _I	-	-	±1	μA	V _{IN} =0~3.3V	*1,2	
Input L Current to Pull-up Resistor	I _{IL}	-150	-100	-50	μA	V _{IN} =0V	*3	
Input H Current to Pull-down Resistor	I _{IH}	35	70	105	μA	V _{IN} =3.3V	*4	
Output Voltage	H-level Voltage	V _{OH}	2.75	-	-	V	I _O =-0.6mA	*5
	L-level Voltage	V _{OL}	-	-	0.55	V	I _O =0.6mA	*5

Relevant Pins

*1 CMOS input pin
XI (pin 60)

*2 CMOS hysteresis input pin
MODE (pin 2), SCANTEST (pin 3), SDA (pin 4), SCL (pin 5)

*3 CMOS hysteresis input pin with built-in pull-up resistance
RESETB (pin 8), DATA1 (pin 52), BCKI1 (pin 53), LRCKI1 (pin 54), DATA2 (pin 55), BCKI2 (pin 56), LRCKI2 (pin 57), DATA3 (pin 58), BCKI3 (pin 63), LRCKI3 (pin 64), DATA4 (pin 65), BCKI4 (pin 66), LRCKI4 (pin 67), AMCLKI1 (pin 68), AMCLKI2 (pin 69), AMCLKI3 (pin 75), AMCLKI4S (pin 76)

*4 CMOS input pin with built-in pull-down resistance
I2CADR1 (pin 6), I2CADR2 (pin 7)

*5 CMOS output pin
SDA (pin 4), ERROR (pin 39), DATAOC (pin 42), BCKOC (pin 43), LRCKOC (pin 44), DATAOB (pin 45), BCKOB (pin 46), LRCKOB (pin 47), DATAOA (pin 48), BCKOA (pin 49), LRCKOA (pin 50), XO (pin 61), AMCLKI4S (pin 76), AMCLKOA (pin 77), AMCLKOB (pin 78), AMCLKOC (pin 79)

●Electrical Characteristics (Analog system)

$V_{DD}=3.3V$ (Unless otherwise specified $T_a=25^{\circ}C$, $R_L=10k\Omega$, Standard V_C)

Item	Symbol	Standard Values			Unit	Applicable Pins/Conditions
		Min.	Typ.	Max.		
Total						
Circuit Current	I_Q	-	60	90	mA	DVDDIO1,DVDDIO2,DVDDIO3,DVDDREG , DVDDPLL,AVDDAD1,ADVDDAD2, AVDDDA1,AVDDAR2,AVDDAL2, AVDDAR3,AVDDAL3
Regulator						
Output Voltage	V_{REG}	-	1.5	-	V	$I_O=100mA$
PLL_ASRC						
Lock Frequency (8 times frequency multiplier)	F_{LKB}	-	24.576	-	MHz	BCK=3.072MHz (fs=48kHz)
Sigma-delta audio ADC						
Maximum Input Amplitude	V_{IMAX}	-	-	0.7	Vrms	
Distortion rate(THD+N)	THD_{AD}	-	0.02	0.05	%	1kHz, -0.5dB
S/N	S/N_{AD}	-	90	-	dB	$A_{IN}=0.7V_{rms}$,1kHz,A-weighted
Input Impedance	R_I	42	60	78	k Ω	
Sigma-delta audio DAC						
Maximum Output Amplitude	V_{OMAX}	0.63	0.75	0.86	Vrms	
Distortion rate(THD+N)	THD_{DA}	-	0.005	0.03	%	0dB,1kHz
S/N	S/N_{DA}	-	96	-	dB	0dB,1kHz,A-weighted
16bit DAC Section						
Maximum Output Amplitude	V_{OMAX}	0.65	0.77	0.88	Vrms	
Distortion rate(THD+N)	THD_{DA}	-	0.03	-	%	0dB,1kHz
S/N	S/N_{DA}	-	90	-	dB	0dB,1kHz,A-weighted

●Block diagram

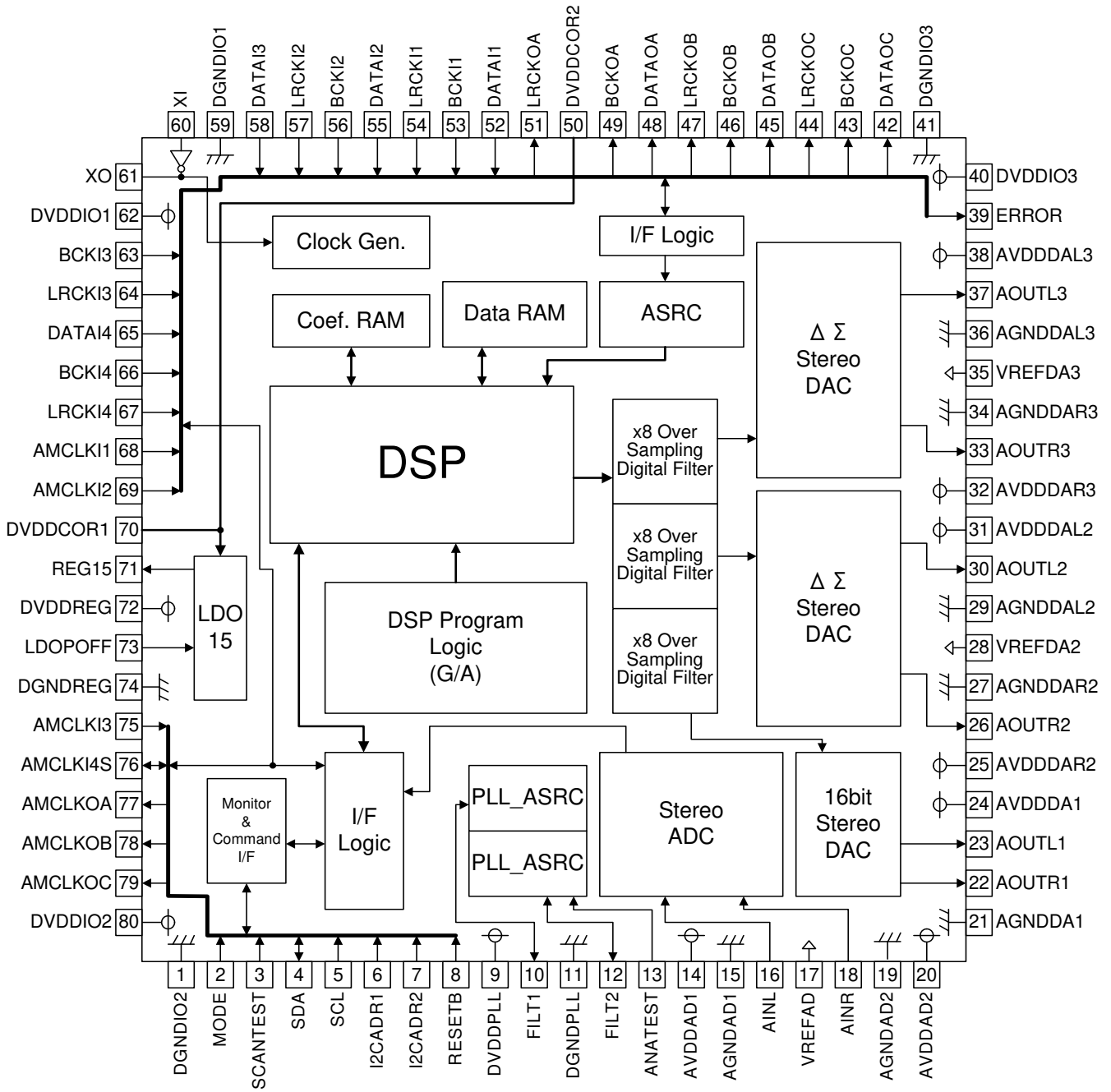
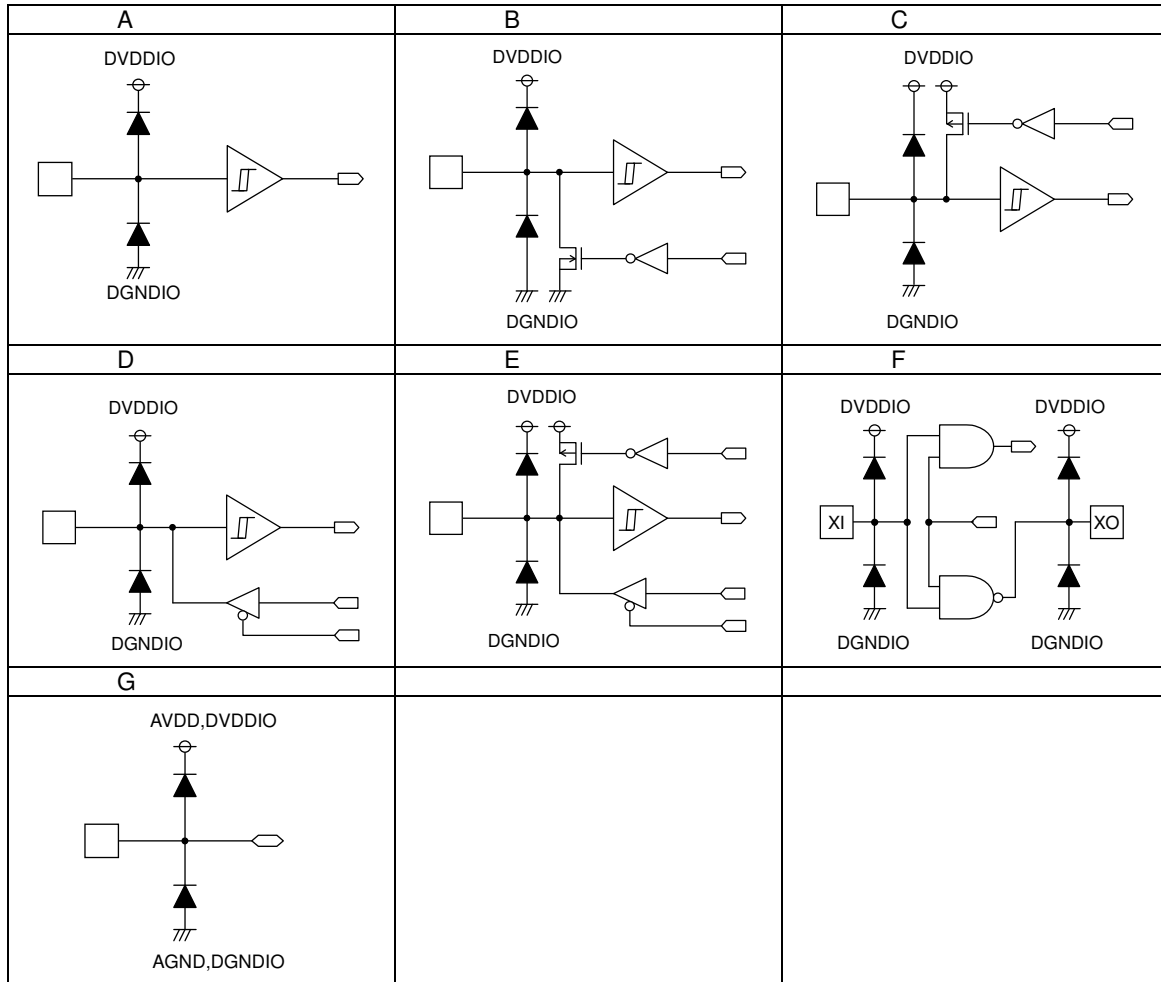

Fig.2 Block diagram

●Pin Description(s)

No.	Name	Description of terminals	Type	No.	Name	Description of terminals	Type
1	DGNDIO2	Digital I/O GND2	—	41	DGNDIO3	Digital I/O GND 3	—
2	MODE	Test mode select pin	A	42	DATAOC	I ² S audio data output C	D
3	SCANTEST	Digital test mode select pin	A	43	BCKOC	I ² S audio bit transfer clock output C	D
4	SDA	I ² C data I/O pin	D	44	LRCKOC	I ² S audio LR sampling clock output C	D
5	SCL	I ² C transfer clock input pin	D	45	DATAOB	I ² S audio data output B	D
6	I2CADR1	I ² C slave address select pin 1	B	46	BCKOB	I ² S audio bit transfer clock output B	D
7	I2CADR2	I ² C slave address select pin 2	B	47	LRCKOB	I ² S audio LR sampling clock output B	D
8	RESETB	"L" -> Reset condition	C	48	DATAOA	I ² S audio data output A	D
9	DVDDPLL	PLL power supply	—	49	BCKOA	I ² S audio bit transfer clock output A	D
10	FILT1	PLL_ASRC filter connect terminal 1	G	50	DVDDCOR2	Connects with REG15 Pin	—
11	DGNDPLL	PLL GND	—	51	LRCKOA	I ² S audio LR sampling clock output A	D
12	FILT2	PLL_ASRC filter connect terminal 2	G	52	DATAI1	I ² S audio data input 1	E
13	ANATEST	Analog test mode select pin	G	53	BCKI1	I ² S audio bit transfer clock input 1	E
14	AVDDAD1	Audio ADC power supply 1	—	54	LRCKI1	I ² S audio LR sampling clock input 1	E
15	AGNDAD1	Audio ADC GND 1	—	55	DATAI2	I ² S audio data input 2	E
16	AINL	Analog signal Lch input pin	G	56	BCKI2	I ² S audio bit transfer clock input 2	E
17	VREFAD	ADC reference voltage pin	G	57	LRCKI2	I ² S audio LR sampling clock input 2	E
18	AINR	Analog signal Rch input pin	G	58	DATAI3	I ² S audio data input 3	E
19	AGNDAD2	Audio ADC GND 2	—	59	DGNDIO1	Digital I/O GND1	—
20	AVDDAD2	Audio ADC power supply 2	—	60	XI	X'tal connecting (input) terminal	F
21	AGNDDA1	Audio DAC GND 1	—	61	XO	X'tal connecting terminal	F
22	AOUTR1	Audio DAC Rch output pin 1	G	62	DVDDIO1	Digital I/O power supply 1	—
23	AOUTL1	Audio DAC Lch output pin 1	G	63	BCKI3	I ² S audio bit transfer clock input 3	E
24	AVDDDA1	Audio DAC power supply 1	—	64	LRCKI3	I ² S audio LR sampling clock input 3	E
25	AVDDDA2	Audio DAC Rch power supply 2	—	65	DATAI4	I ² S audio data input 4	E
26	AOUTR2	Audio DAC Rch output pin 2	G	66	BCKI4	I ² S audio bit transfer clock input 4	E
27	AGNDDAR2	Audio DAC Rch GND 2	—	67	LRCKI4	I ² S audio LR sampling clock input 4	E
28	VREFDA2	DAC reference voltage 2	G	68	AMCLKI1	I ² S synchronous clock input 1	E
29	AGNDDAL2	Audio DAC Lch GND 2	—	69	AMCLKI2	I ² S synchronous clock input 2	E
30	AOUTL2	Audio DAC Lch output pin 2	G	70	DVDDCOR1	Connects with REG15 Pin	—
31	AVDDDAL2	Audio DAC Lch power supply 2	—	71	REG15	Built in regulator voltage output	G
32	AVDDDA3	Audio DAC Rch power supply 3	—	72	DVDDREG	Power supply for built in regulator	—
33	AOUTR3	Audio DAC Rch output pin3	G	73	LDOPOFF	Power off signal input for regulator	G
34	AGNDDAR3	Audio DAC Rch GND 3	—	74	DGNDREG	GND for built in regulator	—
35	VREFDA3	DAC reference voltage 3	G	75	AMCLKI3	I ² S synchronous clock input 3	E
36	AGNDDAL3	Audio DAC Lch GND 3	—	76	AMCLKI4S	I ² S synchronous clock Input 4 or S/PDIF output	E
37	AOUTL3	Audio DAC Lch output pin 3	G	77	AMCLKOA	I ² S synchronous clock output A	D
38	AVDDDAL3	Audio DAC Lch power supply 3	—	78	AMCLKOB	I ² S synchronous clock output B	D
39	ERROR	Sampling frequency input error pin	D	79	AMCLKOC	I ² S synchronous clock output C	D
40	DVDDIO3	Digital I/O power supply 3	—	80	DVDDIO2	Digital I/O power supply 2	—

● Pin Equivalent Circuit Diagrams



1. Command Interface

BU9406KS2 uses the I²C bus format for the command interface with the host CPU.

With BU9406KS2, in addition to write mode, read mode read-out is possible with many registers.

BU9406KS2 assigns a 1-byte select address in addition to the slave address and performs write-in and read-out.

The I²C bus slave mode format is as follows:

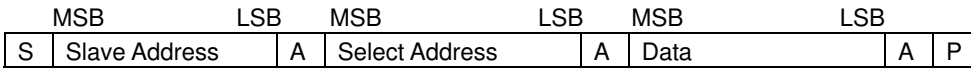

S: Start Condition

Slave Address: Adds either a read mode (H") or write mode (L") bit to the slave address (7bit) configured by I2CADR1 and I2CADR2, sending a total of 8 bits of data. (MSB first)

A: Acknowledge An acknowledge bit is added on to each bit of data transmitted.
 When data transmission is being done correctly, "L" is transmitted.
 "H" transmission means there was no acknowledge.

Select Address: BU9406KS2 uses a 1-byte select address. (MSB first)

Data: Data byte, transmitted data (MSB first)

P: Stop condition

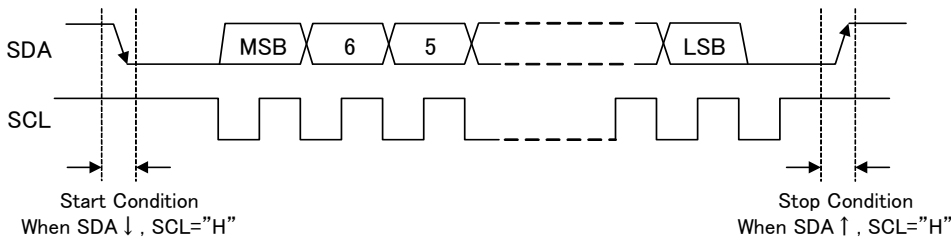

1-1. Data Write-In

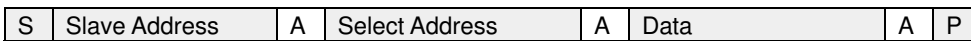

□ : Master to Slave □ : Slave to Master

MSB							LSB
A6	A5	A4	A3	A2	A1	A0	R/W
1	0	0	0	0	0	0	0

Slave Address Configuration for BU9406KS2

Pin Configuration		Write Mode Slave Address
I2CADR2	I2CADR1	
0	0	80h
0	1	82h
1	0	84h
1	1	86h

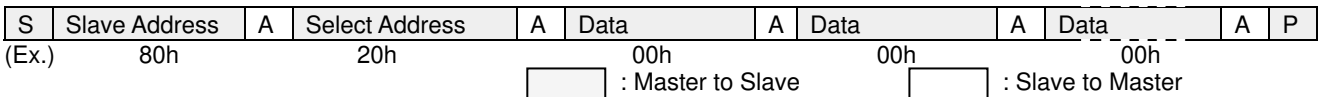

Write-in Procedure

Step	Clock	Master	Slave(BU9406KS2)	Note
1		Start Condition		
2	7	Slave Address		&h80 (&h82, &h84, &h86)
3	1	R/W (0)		
4	1		Acknowledge	
5	8	Select Address		Write-in target register: 8bit
6	1		Acknowledge	
7	8	Data		8bit write-in data
8	1		Acknowledge	
9		Stop Condition		

- When transmitting continuous data, the auto-increment function moves the select address up by one.
Repeat steps 7 and 8.

1-2. Data Read-out

During read-out, the corresponding read-out address is first written into the &hD0 address register (&h20h in the example). In the following stream, the data is read out after the slave address. Do not return an acknowledge after completing the reception.

S	Slave Address	A	Request Address	A	Select Address	A	P
---	---------------	---	-----------------	---	----------------	---	---

(ex.) 80h D0h 20h

S	Slave Address	A	Data 1	A	Data 2	A	-----	A	Data N	Ā	P
---	---------------	---	--------	---	--------	---	-------	---	--------	---	---

(ex.) 81h **h **h **h

: Master to Slave, : Slave to Master, A: With acknowledge, Ā: Without acknowledge

Read-out Procedure

Step	Clock	Master	Slave(BU9406KS2)	Note
1		Start Condition		
2	7	Slave Address		&h80 (&h82, &h84, &h86)
3	1	R/W (0)		
4	1		Acknowledge	
5	8	Request Address		I ² C read-out address &hD0
6	1		Acknowledge	
7	8	Select Address		Read-out target register: 8bit
8	1		Acknowledge	
9	1	Stop Condition		
10	1	Start Condition		
11	7	Slave Address		&h81 (&h82, &h85, &h87)
12	1	R/W (1)		
13	1		Acknowledge	
14	8		Data	8bit read-out data
15	1	Acknowledge		
16		Stop Condition		

- When transmitting continuous data, the auto-increment function moves up the select address by one.
Repeat steps 14 and 15.

1-3. Control Signal Specifications

○ Electrical Characteristics and Timing for Bus Line and I/O Stage

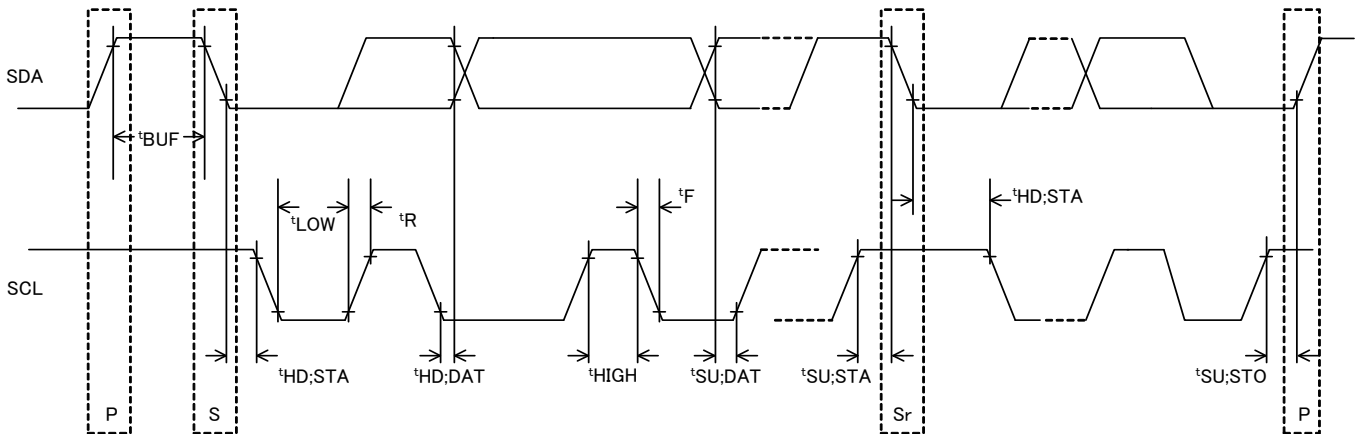

Fig.1-1: Timing Chart

Chart 1-1: SDA and SCL Bus Line Characteristics (Unless specified, $T_a=25^{\circ}\text{C}$ and $V_{DD}=3.3\text{V}$)

Parameters	Symbol	High-Speed Mode		Unit
		Min.	Max.	
1 SCL clock frequency	fSCL	0	400	kHz
2 Bus free time between “stop” condition and “start” condition	t_{BUF}	1.3	—	μS
3 Hold time (re-transmit) “start” condition. After this period, the first clock pulse is generated.	$t_{HD;STA}$	0.6	—	μS
4 SCL clock LOW state hold time	t_{LOW}	1.3	—	μS
5 SCL clock HIGH state hold time	t_{HIGH}	0.6	—	μS
6 Re-transmit set-up time of “start” condition	$t_{SU;STA}$	0.6	—	μS
7 Data hold time	$t_{HD;DAT}$	0 ¹⁾	—	μS
8 Data setup time	$t_{SU;DAT}$	100	—	ns
9 SDA and SCL signal stand-up time	t_{R}	20+Cb	300	ns
10 SDA and SCL signal stand-down time	t_{F}	20+Cb	300	ns
11 Set-up time for “stop” condition	$t_{SU;STO}$	0.6	—	μS
12 Each bus line’s capacitive load	Cb	—	400	pF

The values above correspond with $V_{IH\ min}$ and $V_{IL\ max}$ levels.

- 1) Because the transmission device exceeds the undefined domain of the SCL fall edge, it is necessary to internally provide a minimum 300ns hold time for the SDA signal (of $V_{IH\ min}$ of SCL signal).

The characteristics above are logical values for design; guarantees in the form of delivery inspections are not offered. In the event of a problem, comprehensive consultation and support will be provided.

2. Data and Clock Switching

Below is the in/output system diagram for BU9406KS2.

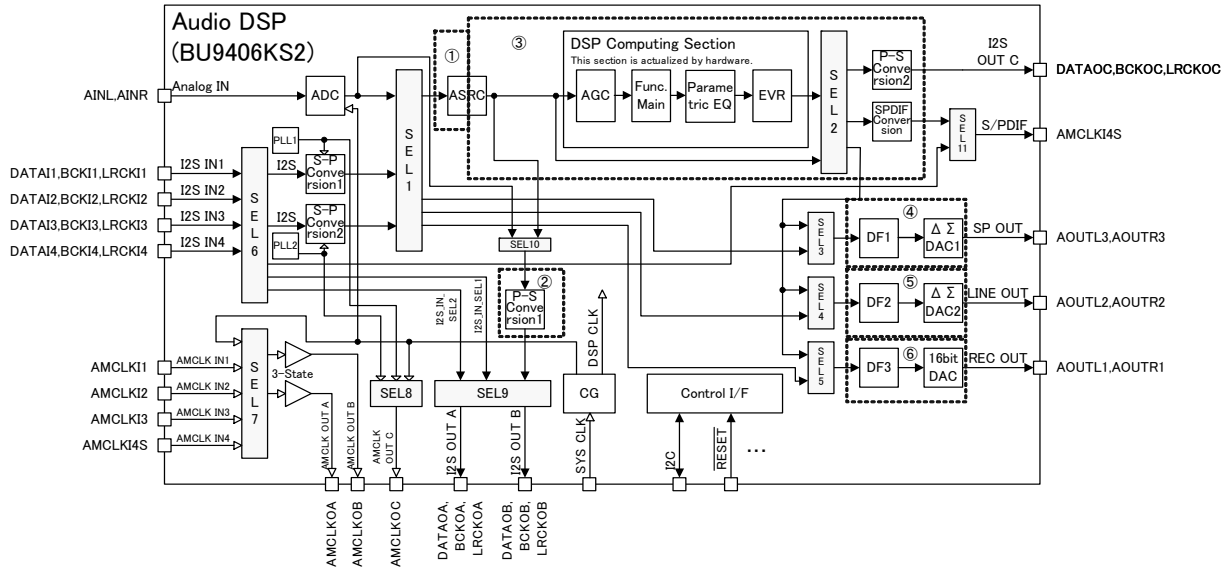

BU9406KS2 has a 4-line digital stereo input, 1-line analog stereo input, 4-line digital stereo output and 3-line analog stereo output.

The digital data input to the DSP computing section is first changed to $f_s=48\text{kHz}$ data at the ASRC (asynchronous sampling rate converter).

DSP computing section output is changed to either I^2S format digital output, S/PDIF format digital serial output or analog output.

2-1. ASRC Input Selection (SEL1)

Default = 0

Select Address	Value	Operation Description
&h03 [5 : 4]	0	Inputs analog signals converted to digital data
	1	Inputs via S-P conversion 1 (refer to &h05[5:4])
	2	Inputs via S-P conversion 2 (refer to &h05[1:0])

S-P conversions 1 and 2 convert I^2C format serial data to 24bit parallel data.

2-2. DF1 Input Selection (SEL1, SEL2, SEL3)

Default = 0

Select Address	Value	Operation Description
&h03 [2 : 0]	0	Inputs analog signals converted to digital data
	1	Inputs via S-P conversion 1 (refer to &h05[5:4])
	2	Inputs via S-P conversion 2 (refer to &h05[1:0])
	3	Inputs data before DSP processing
	4	Inputs data after DSP processing

2-3. DF2 Input Selection (SEL1, SEL2, SEL4)

Default = 0

Select Address	Value	Operation Description
&h04 [6 : 4]	0	Inputs analog signals converted to digital data
	1	Inputs via S-P conversion 1 (refer to &h05[5:4])
	2	Inputs via S-P conversion 2 (refer to &h05[1:0])
	3	Inputs data before DSP processing
	4	Inputs data after DSP processing

2-4. DF3 Input Selection (SEL1, SEL2, SEL5)

Default = 0

Select Address	Value	Operation Description
&h04 [2 : 0]	0	Inputs analog signals converted to digital data
	1	Inputs via S-P conversion 1 (refer to &h05[5:4])
	2	Inputs via S-P conversion 2 (refer to &h05[1:0])
	3	Inputs data before DSP processing
	4	Inputs data after DSP processing

2-5. S-P Conversion 1 Input Selection (SEL6)

Default = 0

Select Address	Value	Operation Description
&h05 [5 : 4]	0	Inputs data from I2S_IN1
	1	Inputs data from I2S_IN2
	2	Inputs data from I2S_IN3
	3	Inputs data from I2S_IN4

2-6. S-P Conversion 2 Input Selection (SEL6)

Default = 0

Select Address	Value	Operation Description
&h05 [1 : 0]	0	Inputs data from I2S_IN1
	1	Inputs data from I2S_IN2
	2	Inputs data from I2S_IN3
	3	Inputs data from I2S_IN4

2-7. Clock Output Selection (SEL&) to AMCLKOA Pin

Default = 0

Select Address	Value	Operation Description
&h06 [6 : 4]	0	Outputs Hi-z
	1	Outputs 256fs (12.288MHz) clock used in DSP
	2	Outputs clock from AMCLK_IN1
	3	Outputs clock from AMCLK_IN2
	4	Outputs clock from AMCLK_IN3
	5	Outputs clock from AMCLK_IN4

2-8. Clock Output Selection to AMCLKOB Pin (SEL7)

Default = 0

Select Address	Value	Operation Description
&h06 [2 : 0]	0	Outputs Hi-z
	1	Outputs 256fs (12.288MHz) clock used in DSP
	2	Outputs clock from AMCLK_IN1
	3	Outputs clock from AMCLK_IN2
	4	Outputs clock from AMCLK_IN3
	5	Outputs clock from AMCLK_IN4

2-9. Clock Output Selection to AMCLKOC Pin (SEL8)

Default = 0

Select Address	Value	Operation Description
&h07 [5 : 4]	0	Outputs 256fs (12.288MHz) clock used in DSP
	1	Outputs 256fs clock extracted by S-P conversion 1 PLL1
	2	Outputs 256fs clock extracted by S-P conversion 2 PLL2

2-10. Output Selection to DATAOA Pin (SEL6, SEL9)

Default = 0

Select Address	Value	Operation Description
&h08 [6 : 4]	0	Outputs data from I2S_IN1
	1	Outputs data from I2S_IN2
	2	Outputs data from I2S_IN3
	3	Outputs data from I2S_IN4
	4	Outputs data from P-S conversion 1 (refer to &h09[7])

P-S conversion 1 converts 24bit parallel data to I²C format serial data.**2-11. Output Selection to DATAOB Pin (SEL6, SEL9)**

Default = 0

Select Address	Value	Operation Description
&h08 [2 : 0]	0	Outputs data from I2S_IN1
	1	Outputs data from I2S_IN2
	2	Outputs data from I2S_IN3
	3	Outputs data from I2S_IN4
	4	Outputs data from P-S conversion 1 (refer to &h09[7])

2-12. Output Selection to DATAOC Pin (SEL2)

Default = 0

Select Address	Value	Operation Description
&h09 [4]	0	Inputs data before DSP processing
	1	Outputs data after DSP processing

2-13. Input Selection to P-S Conversion 1 (SEL10)

Default = 0

Select Address	Value	Operation Description
&h09 [7]	0	Outputs data from AD conversion
	1	Outputs data after conversion to fs=48kHz at ASRC

2-15. Output Selection When Configuring AMCLK4S Pin to S/PDIF Output (SEL2, SEL6, SEL11)

Default = 0

Select Address	Value	Operation Description
&h09 [2 : 0]	0	Inputs data before DSP processing
	1	Outputs data after DSP processing
	2	Outputs data from I2S_IN1 (Only output data in S/PDIF format)
	3	Outputs data from I2S_IN2 (Only output data in S/PDIF format)
	4	Outputs data from I2S_IN3 (Only output data in S/PDIF format)
	5	Outputs data from I2S_IN4 (Only output data in S/PDIF format)

2-16. AMCLK4S Pin In/Output Switching (SEL2)

Default = 0

Select Address	Value	Operation Description
&h09 [3]	0	Clock input
	1	S/PDIF data output (refer to &h11, &h12 and &h13)

There are three types of system clocks used by the DSP or DF+DAC sections of BU9406KS2.

One is the 24.576MHz (512fs) system clock from the XI pin, and the other two are 512fs clocks generated by PLL1 and PLL2 from the input clocks BCK11~3.

2-17. System Clock Selection of ASRC Input Section (used for up-sampling) (Dotted line ①)

Default = 0

Select Address	Value	Operation Description
&h0A [7 : 6]	0	24.576MHz (512fs) system clock from XI pin
	1	512fs clock extracted from S-P conversion 1 PLL1
	2	512fs clock extracted from S-P conversion 2 PLL2

2-18. System Clock Selection for ASRC Output Section (used for down-sampling), P-S Conversion 2 and S/PDIF Output (Dotted line ③)

Default = 0

Select Address	Value	Operation Description
&h0A [1 : 0]	0	24.576MHz (512fs) system clock from XI pin
	1	512fs clock extracted from S-P conversion 1 PLL1
	2	512fs clock extracted from S-P conversion 2 PLL2

2-19. System Clock Selection for P-S Conversion 1 (Dotted line ②)

Default = 0

Select Address	Value	Operation Description
&h0A [5 : 4]	0	24.576MHz (512fs) system clock from XI pin
	1	512fs clock extracted from S-P conversion 1 PLL1
	2	512fs clock extracted from S-P conversion 2 PLL2

2-20. System Clock Selection of DF1 and $\Delta\Sigma$ DAC 1 (Dotted line ④)

Default = 0

Select Address	Value	Operation Description
&h0B[7 : 6]	0	24.576MHz (512fs) system clock from XI pin
	1	512fs clock extracted from S-P conversion 1 PLL1
	2	512fs clock extracted from S-P conversion 2 PLL2

2-21. System Clock Selection of DF2 and $\Delta\Sigma$ DAC2 (Dotted line ⑤)

Default = 0

Select Address	Value	Operation Description
&h0B[5 : 4]	0	24.576MHz (512fs) system clock from XI pin
	1	512fs clock extracted from S-P conversion 1 PLL1
	2	512fs clock extracted from S-P conversion 2 PLL2

2-22. System Clock Selection of DF3 and 16bit DAC (Dotted line ⑥)

Default = 0

Select Address	Value	Operation Description
&h0B[3 : 2]	0	24.576MHz (512fs) system clock from XI pin
	1	512fs clock extracted from S-P conversion 1 PLL1
	2	512fs clock extracted from S-P conversion 2 PLL2

3. S-P Conversion 1 and S-P Conversion 2

BU9406KS2 has two built-in serial-parallel conversion circuits. (S-P Conversion 1 and S-P Conversion 2)

S-P conversions 1 and 2 are blocks which receive 3-line serial input audio data from pins and convert it to parallel data.

Input from DATA1, BCKI1 and LRCKI1 (pins 52,53 and 54), DATA2, BCKI2 and LRCKI2 (pins 55, 56, and 57), DATA3, BCKI3 and LRCKI3 (pins 58, 63 and 64), and DATA4, BCKI4 and LRCKI4 (pins 65, 66 and 67) are selected.

The three input formats are IIS, left-justified and right-justified. The bit clock frequency may be selected from either 64fs or 48fs, but when 48fs is selected, the input format is always right-justified. 16bit, 20bit and 24bit output may be selected for each format.

Below are the timing charts for each transfer format.

IIS Format

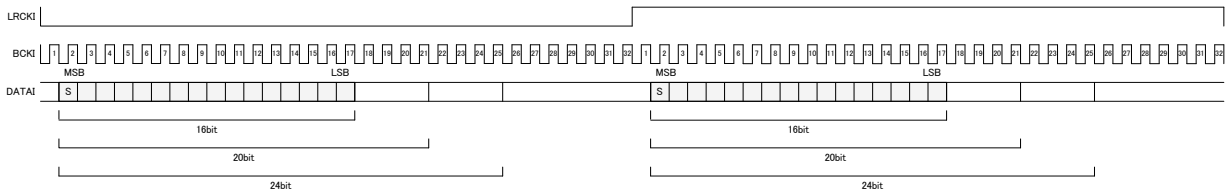

Left-Justified Format

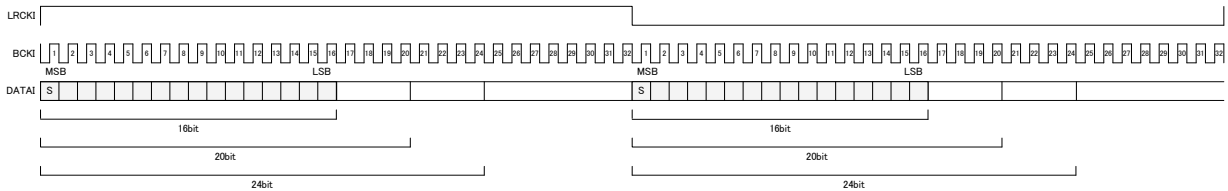

Right-Justified Format

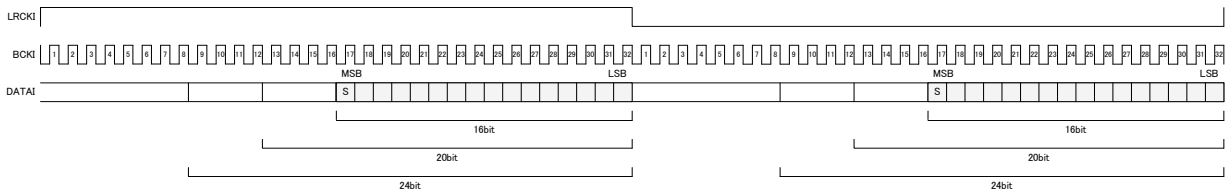

48fs

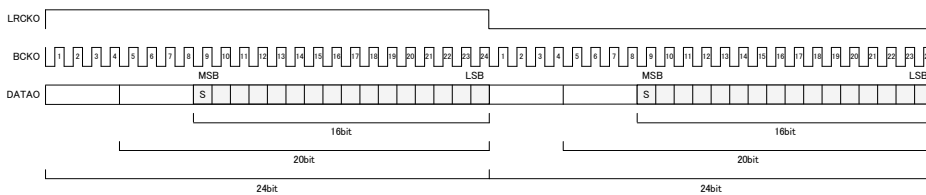

3-1. Input Selection for S-P Conversions 1 and 2

Default = 0

Select Address	Value	Operation Description
S-P Conversion 1 &h05[5:4]	0	Input data from I2S_IN1
S-P Conversion 2 &h05[1:0]	1	Input data from I2S_IN2
	2	Input data from I2S_IN3
	3	Input data from I2S_IN4

3-2. Bit Clock Frequency Configuration for 3-line Serial Input

Default = 0

Select Address	Value	Operation Description
S-P Conversion 1 &h0C [4]	0	64fs format
S-P Conversion 2 &h0D [4]	1	48fs format

3-3. Format Configuration for 3-line Serial Input

Default = 0

Select Address	Value	Operation Description
S-P Conversion 1 &h0C[3:2]	0	IIS format
S-P Conversion 2 &h0D[3:2]	1	Left-justified format
	2	Right-justified format

3-4. Data Bit Width Configuration for 3-line Serial Input

Default = 0

Select Address	Value	Operation Description
S-P Conversion 1 &h0C[1:0]	0	16 bit
S-P Conversion 2 &h0D[1:0]	1	20 bit
	2	24 bit

4. Digital Sound Processing (DSP)

BU9406KS2's digital sound processing (DSP) section is constructed with specific hardware optimal for FPD TVs. BU9406KS2 uses this special DSP to perform the following processes:

Pre-scaler, Channel Mixer, Pseudo-Stereo, Surround, P²Bass, P²Treble, Parametric Equalizer, EVR & Balance, Compression, Post-scaler, Clipper

4-1. Overview and Signal Flow of DSP Section

- Word length: 28 bit (DATA RAM)
- Machine Cycle: 40.7ns (512fs, fs=48kHz)
- Multiplier: 28×24 → 52 bit
- Adder: 28+28 → 28 bit
- Data RAM: 256×28 bit
- Coefficient RAM: 128×24 bit
- Sampling Frequency: fs=48kHz
- Master Clock: 512fs (24.576MHz, fs=48kHz)

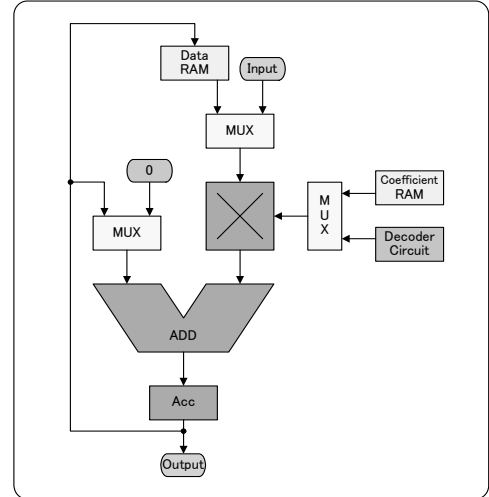

16bit and 24bit digital signals are input to the DSP, but there is an overflow margin of +4bit (+24dB) on the top side.

For processes that exceed this range, there is a clipping process within the DSP.

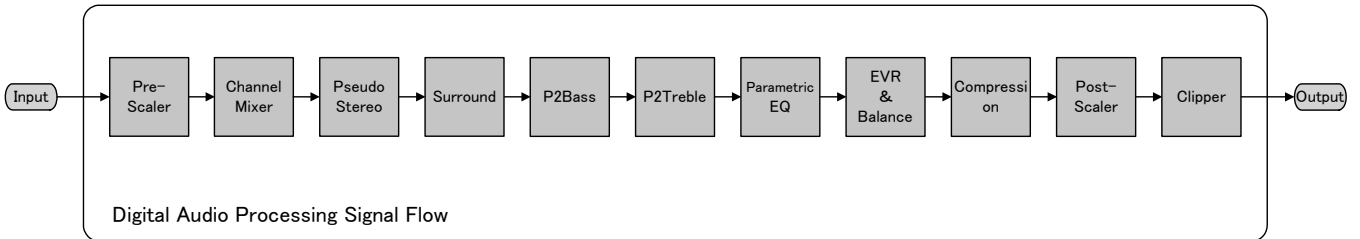

4-2. Pre-Scaler

When the digital signals are input to the sound DSP the level may be full-scale input, causing overflow from surround or equalizer treatment, so the pre-scaler adjusts the input gain.

Analog signals are changed to digital values with the A/D converter, and the gain can be adjusted with the pre-scaler even when the input level is low.

The adjustment range can be configured in 2dB increments from +16dB to -44dB.

Default = 00

Select Address	Operation Description							
&h20 [4 : 0]	Command Value	Gain	Command Value	Gain	Command Value	Gain	Command Value	Gain
	00	0dB	08	-16dB	10	-32dB	18	+16dB
	01	-2dB	09	-18dB	11	-34dB	19	+14dB
	02	-4dB	0A	-20dB	12	-36dB	1A	+12dB
	03	-6dB	0B	-22dB	13	-38dB	1B	+10dB
	04	-8dB	0C	-24dB	14	-40dB	1C	+8dB
	05	-10dB	0D	-26dB	15	-42dB	1D	+6dB
	06	-12dB	0E	-28dB	16	-44dB	1E	+4dB
	07	-14dB	0F	-30dB	17	-∞	1F	+2dB

4-3. Channel Mixer

Performs the mixing configuration of the left and right channel sounds of digital signals input to the sound DSP. Stereo signals can be changed to monaural here.

Mixes DSP Lch input data.

Default = 0

Select Address	Value	Operation Description
&h2A [7 : 6]	0	Inputs Lch data
	1	Inputs (Lch+Rch)/2 data
	2	Inputs (Lch+Rch)/2 data
	3	Inputs Rch data

Mixes DSP Rch input data.

Default = 0

Select Address	Value	Operation Description
&h2A [5 : 4]	0	Inputs Rch data
	1	Inputs (Lch+Rch)/2 data
	2	Inputs (Lch+Rch)/2 data
	3	Inputs Lch data

4-4. Pseudo-Stereo 2

Recreates stereo feel in monaural sound through signal treatment.

The quality of this pseudo-stereo treatment is higher than that of the pseudo-stereo of “5-5 Surround and Pseudo-Stereo 1”.

Selection of Pseudo-Stereo 2 Filter Effect

Default = 0

Select Address	Value	Operation Description
&h71 [1 : 0]	0	Pseudo-stereo OFF
	1	Effect configured to “weak”
	2	Effect configured to “strong”

Sound is further enhanced when used together with surround (&h70[7]=1).

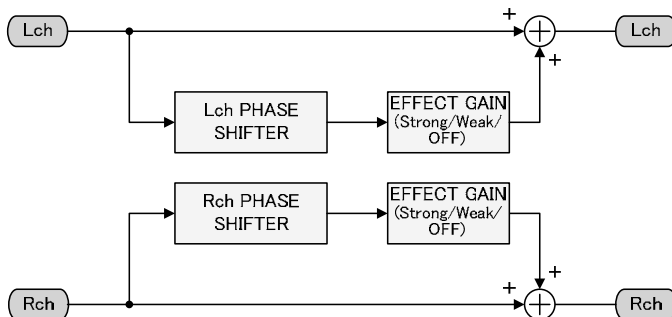

4-5. Surround (Matrix Surround 3D) and Pseudo-Stereo 1

Actualizes surround sound with a vast sweet spot, which allows longer viewing with less fatigue.

Recreates natural mid- and high-range sound, actualizing sound field that does not take away from the stability of the vocal.

Using the loop function simulates extra steps of the phase shifter.

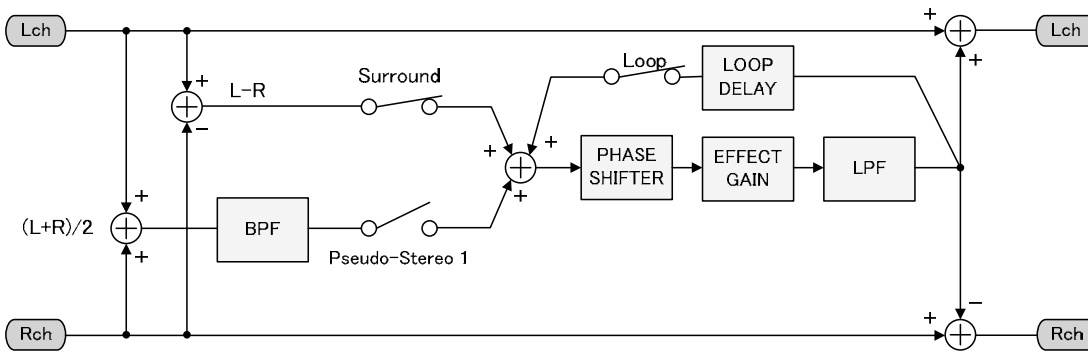

Turning Surround Function ON/OFF

Default = 0

Select Address	Value	Operation Description
&h70 [7]	0	Turns surround effect OFF
	1	Turns surround effect ON

Turning Pseudo-Stereo Function 1 ON/OFF (Different function from 5-4 pseudo-stereo 2)

Default = 0

Select Address	Value	Operation Description
&h70 [6]	0	Turns pseudo-stereo effect OFF
	1	Turns pseudo-stereo effect ON

Loop Usage Configuration

Default = 0

Select Address	Value	Operation Description
&h70 [5]	0	Loop OFF
	1	Loop ON

Delay Length Configuration in Loop use

Default = 0

Select Address	Value	Operation Description
&h71 [7 : 6]	0	1 sample
	1	64 samples
	2	128 samples
	3	255 samples

Surround Gain Configuration

Default = 0

Select Address	Operation Description																																							
&h70 [3 : 0]	<table border="1"> <thead> <tr> <th>Command Value</th> <th>Gain</th> <th>Command Value</th> <th>Gain</th> </tr> </thead> <tbody> <tr> <td>0</td> <td>0dB</td> <td>8</td> <td>-8dB</td> </tr> <tr> <td>1</td> <td>-1dB</td> <td>9</td> <td>-9dB</td> </tr> <tr> <td>2</td> <td>-2dB</td> <td>A</td> <td>-10dB</td> </tr> <tr> <td>3</td> <td>-3dB</td> <td>B</td> <td>-11dB</td> </tr> <tr> <td>4</td> <td>-4dB</td> <td>C</td> <td>-12dB</td> </tr> <tr> <td>5</td> <td>-5dB</td> <td>D</td> <td>-13dB</td> </tr> <tr> <td>6</td> <td>-6dB</td> <td>E</td> <td>-14dB</td> </tr> <tr> <td>7</td> <td>-7dB</td> <td>F</td> <td>-15dB</td> </tr> </tbody> </table>				Command Value	Gain	Command Value	Gain	0	0dB	8	-8dB	1	-1dB	9	-9dB	2	-2dB	A	-10dB	3	-3dB	B	-11dB	4	-4dB	C	-12dB	5	-5dB	D	-13dB	6	-6dB	E	-14dB	7	-7dB	F	-15dB
Command Value	Gain	Command Value	Gain																																					
0	0dB	8	-8dB																																					
1	-1dB	9	-9dB																																					
2	-2dB	A	-10dB																																					
3	-3dB	B	-11dB																																					
4	-4dB	C	-12dB																																					
5	-5dB	D	-13dB																																					
6	-6dB	E	-14dB																																					
7	-7dB	F	-15dB																																					

Simultaneous use of surround (Matrix Surround 3D) and pseudo-stereo 1 will not produce optimal results.

4-6. P²Bass (Perfect Pure Bass: Deep Bass Equalizer)

The deep bass equalizer recreates dynamic bass and realistic sound, even with FPD TVs which have limited speaker enclosure.

It actualizes clear, heavy bass with low distortion. Rich and natural bass is obtained, and the vocal range is not affected even when with bass boost.

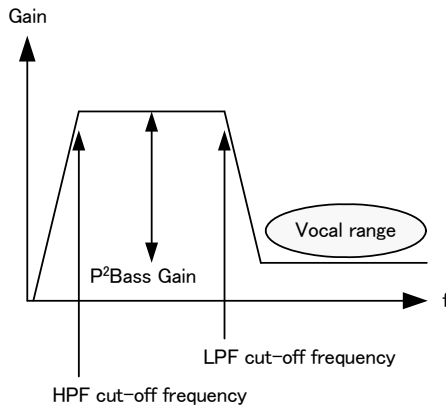

Turning P²Bass Function ON/OFF

Default = 0

Select Address	Value	Operation Description
&h72 [7]	0	P ² Bass function OFF
	1	P ² Bass function ON

P²Bass HPF Cut-off Frequency Configuration

Default = 0

Select Address	Value	Operation Description
&h72 [3 : 2]	0	60Hz
	1	80Hz
	2	100Hz
	3	120Hz

P²Bass LPF Cut-off Frequency Configuration

Default = 0

Select Address	Value	Operation Description
&h72 [1 : 0]	0	120Hz
	1	160Hz
	2	200Hz
	3	240Hz

P²Bass Deep Bass Gain Configuration

Default = 0

Select Address	Operation Description			
&h73 [6 : 4]	Command Value	Gain	Command Value	Gain
	0	+6dB	4	+10dB
	1	+7dB	5	+11dB
	2	+8dB	6	+12dB
	3	+9dB	7	+13dB

4-7. P²Treble (Perfect Pure Treble: Mid-/High-range equalizer)

Actualizes clear, crisp and extensive sound.

With sets which have speakers placed near the bottom, the effect will allow the sound to feel “lifted”.

Turning P²Treble Function ON/OFF

Default = 0

Select Address	Value	Operation Description
&h72 [6]	0	SAS function OFF
	1	SAS function ON

P²Treble Mid-/High-Range Gain Configuration

Default = 0

Select Address	Operation Description			
&h73 [3 : 0]	Command Value	Gain	Command Value	Gain
	0	+1dB	8	+9dB
	1	+2dB	9	+10dB
	2	+3dB	A	+11dB
	3	+4dB	B	+12dB
	4	+5dB	C	+13dB
	5	+6dB	D	+14dB
	6	+7dB	E	+15dB
	7	+8dB		

4-8. Parametric Equalizer

BU9406KS2 has a 2-channel, 12-band parametric equalizer. This is used either to control bass and treble or as an equalizer to improve the frequency characteristics of speakers.

Data Width: 28 bit

Coefficient:: 24 bit (-4~+4)

The first 5 bands configure common coefficients for both Lch and Rch. They are used chiefly to control tone.

The latter 7 bands are used as independent parametric equalizers for Lch and Rch.

There is a built-in soft transition function to change the audio characteristics while sound is being played back.

The configuration diagrams of Lch and Rch parametric equalizers are on the following page.

Collective Load of Coefficients to Coefficient RAM

Default = 0

Select Address	Value	Operation Description
&h40 [7]	0	Load stop
	1	Load start

Monitor for State of Parametric Equalizer (for read-out)

Select Address	Definition	State
&h46 [7]	BUSY signal monitor during coefficient transition	Displays “H” during transition
&h46 [6]	BUSY monitor during coefficient load	Displays “H” during load

Time Configuration for Soft Transition Completion

Default = 0

Select Address	Value	Operation Description
&h45 [5 : 4]	0	21.3ms (1024fs)
	1	42.6ms (2048fs)
	2	10.6ms (512fs)
	3	5.3ms (256fs)

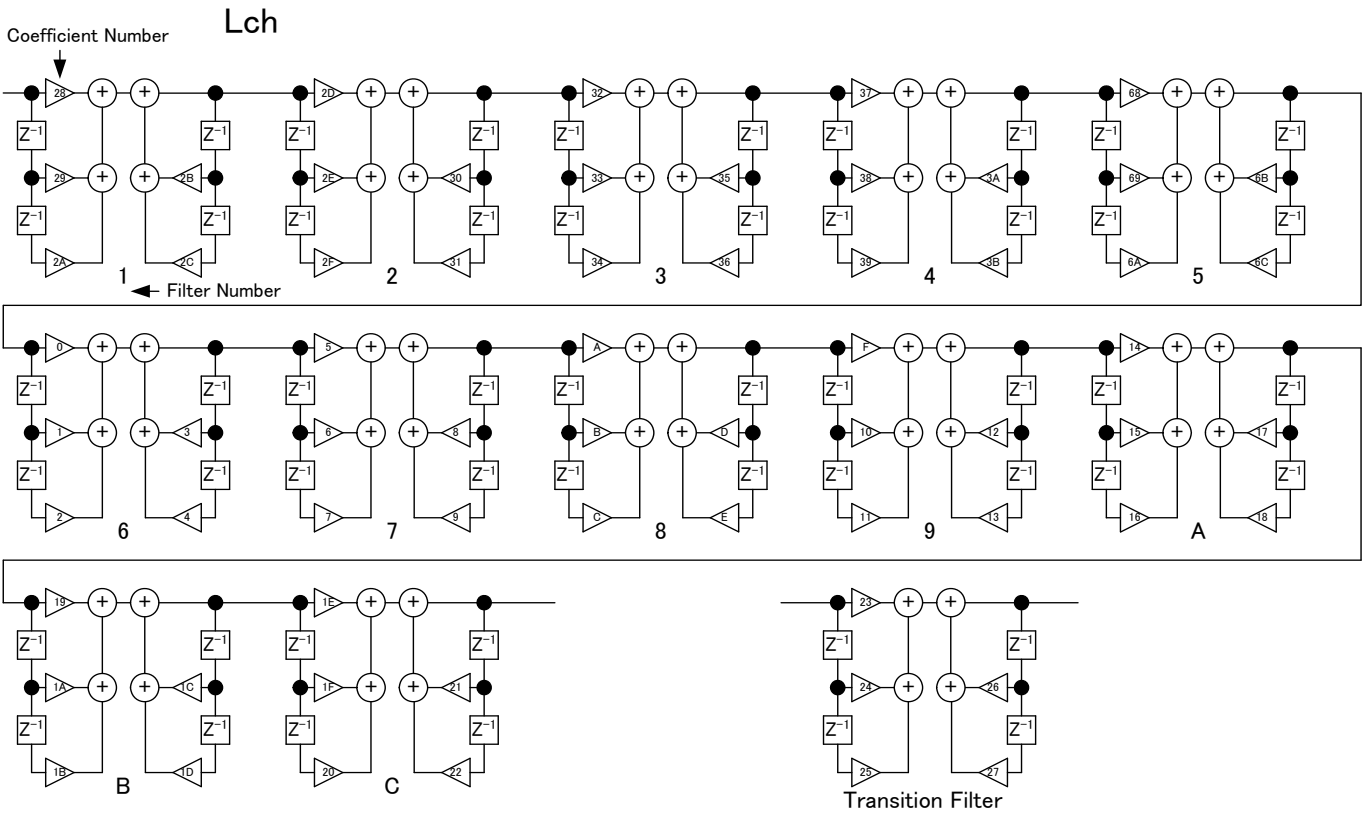

※Coefficient Numbers and Filter Numbers are hexadecimal

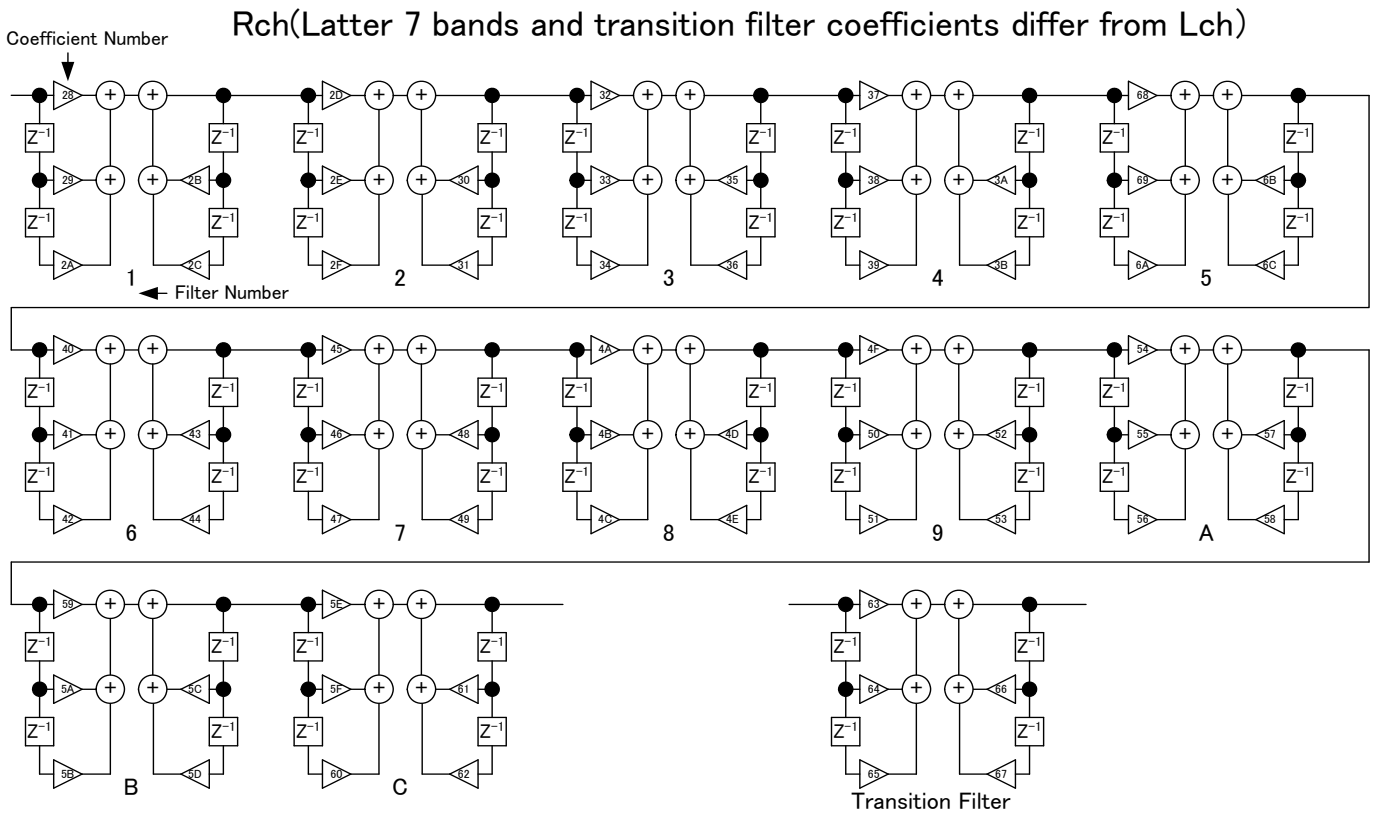

※Coefficient Number and Filter Numbers are hexadecimal

4-8-1. Parametric EQ Coefficient Configuration Method

- ① Set &h40[7] to "L".
- ② Configure the address (7bits) of the coefficient number to be converted at &h41[6:0].
Configure the data (24bits) at &h42[7:0], &h43[7:0] and &h44[7:0].
- ③ Set &h40[7] to "H". Data can be collectively written into the coefficient RAM of the appointed coefficient numbers.
- ④ The write-in to the coefficient RAM completes when &h46[6] is read out and confirmed to be "L", or after a 20μs wait.
Afterwards, set &h40[7] to "L".
- ⑤ With coefficients, h7FFFFFF (maximum value) refers to +4-1LSB and h800000 (minimum value) refers to -4. In addition, h200000 refers to +1, h000000 refers to 0, and hE00000 refers to -1.

4-8-2. Soft Transition Usage Method During Coefficient Switching of Parametric EQ

- ① Configure the transition time at &h45[5:4].
- ② New coefficients are set to the transition filters of two channels. To transit the first 5 bands (same coefficients for both channels), the same coefficients must be set to the transition filters of both channels.
- ③ Set the filter number to transit at &h45[3:0]. Transition begins.
- ④ seni_busy (signal read out at &h46[7]) becomes "H", and turns to "L" when transition is complete.
- ⑤ 0 must be set to &h45[3:0] when transition is complete, finishing the soft transition operation.

4-9. EVR (Electrical Volume) and Balance

The volume can be selected in 0.5dB increments from +24dB to -103dB.

Soft transition is performed when volume is changed. It takes approximately 21ms to go from 0dB to mute.

The balance can be decreased in 1dB increments from the volume configuration value. Soft transition is performed at switch.

Volume Configuration

Default = 00h

Select Address	Operation Description																				
&h24 [7 : 0]	<table border="1"> <thead> <tr> <th>Command Value</th> <th>Gain</th> </tr> </thead> <tbody> <tr><td>00</td><td>+24dB</td></tr> <tr><td>01</td><td>+23.5dB</td></tr> <tr><td>⋮</td><td>⋮</td></tr> <tr><td>30</td><td>0dB</td></tr> <tr><td>31</td><td>-0.5dB</td></tr> <tr><td>32</td><td>-1dB</td></tr> <tr><td>⋮</td><td>⋮</td></tr> <tr><td>FE</td><td>-103dB</td></tr> <tr><td>FF</td><td>-∞</td></tr> </tbody> </table>	Command Value	Gain	00	+24dB	01	+23.5dB	⋮	⋮	30	0dB	31	-0.5dB	32	-1dB	⋮	⋮	FE	-103dB	FF	-∞
Command Value	Gain																				
00	+24dB																				
01	+23.5dB																				
⋮	⋮																				
30	0dB																				
31	-0.5dB																				
32	-1dB																				
⋮	⋮																				
FE	-103dB																				
FF	-∞																				

L/R Balance Configuration

Default = 80h

Select Address	Operation Description																																	
&h25 [7 : 0]	<p>Balance Configuration</p> <table border="1"> <thead> <tr> <th>Command Value</th> <th>Lch</th> <th>Rch</th> </tr> </thead> <tbody> <tr><td>00</td><td>0dB</td><td>-∞</td></tr> <tr><td>01</td><td>0dB</td><td>-126dB</td></tr> <tr><td>⋮</td><td>⋮</td><td>⋮</td></tr> <tr><td>7E</td><td>0dB</td><td>-1dB</td></tr> <tr><td>7F</td><td>0dB</td><td>0dB</td></tr> <tr><td>80</td><td>0dB</td><td>0dB</td></tr> <tr><td>81</td><td>-1dB</td><td>0dB</td></tr> <tr><td>⋮</td><td>⋮</td><td>⋮</td></tr> <tr><td>FE</td><td>-126dB</td><td>0dB</td></tr> <tr><td>FF</td><td>-∞</td><td>0dB</td></tr> </tbody> </table>	Command Value	Lch	Rch	00	0dB	-∞	01	0dB	-126dB	⋮	⋮	⋮	7E	0dB	-1dB	7F	0dB	0dB	80	0dB	0dB	81	-1dB	0dB	⋮	⋮	⋮	FE	-126dB	0dB	FF	-∞	0dB
Command Value	Lch	Rch																																
00	0dB	-∞																																
01	0dB	-126dB																																
⋮	⋮	⋮																																
7E	0dB	-1dB																																
7F	0dB	0dB																																
80	0dB	0dB																																
81	-1dB	0dB																																
⋮	⋮	⋮																																
FE	-126dB	0dB																																
FF	-∞	0dB																																

4-10. Compression

This function automatically adjusts the volume when sound suddenly increases, such as with explosion sounds in TV commercials or movies, in order to prevent shocking the listener.

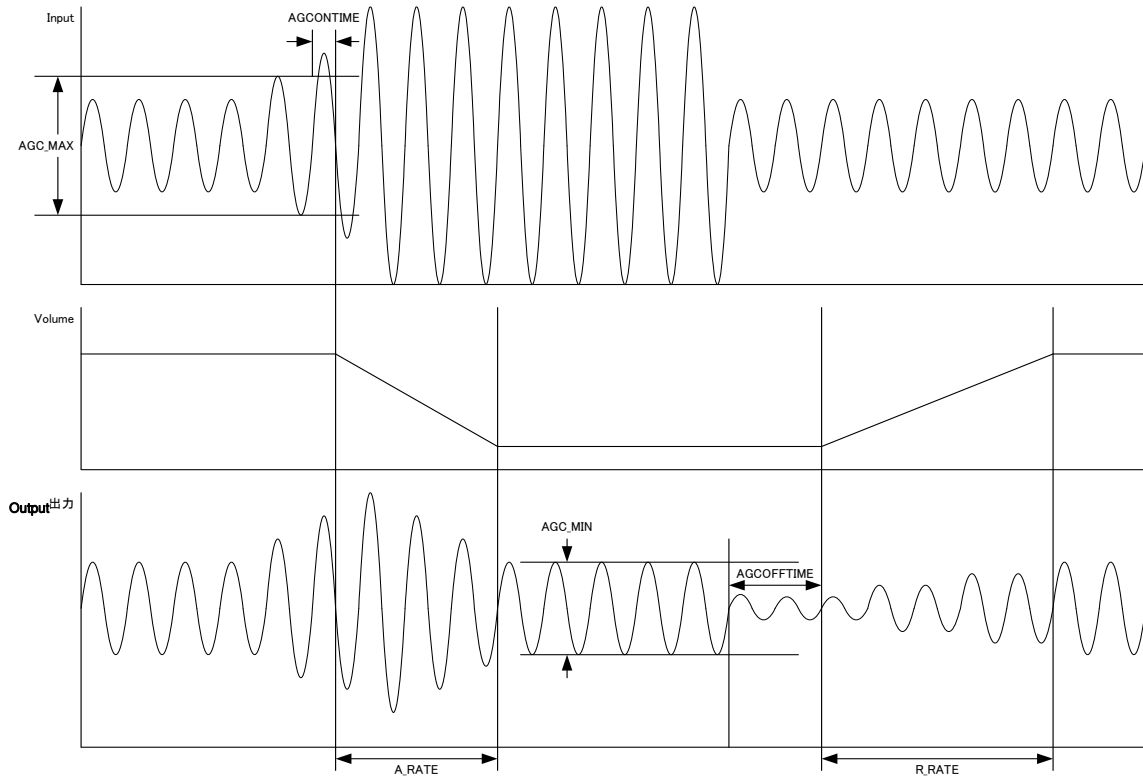

&h21[7] should be set to “H” when the compression function is used.

Default = 0

Select Address	Value	Operation Description
&h21 [7]	0	Compression function OFF
	1	Compression function ON

AGC_MAX is the input level configuration for turning compression ON. It is configured at &h21[6:4].

Default = 0

Select Address	Operation Description			
&h26 [6 : 4]	Command Value	Gain	Command Value	Gain
	0	0dB	4	-12dB
	1	-3dB	5	-18dB
	2	-6dB	6	-24dB
	3	-9dB	7	-30dB

When the time and input level configured at AGCONTIME exceeds AGC_MAX, compression is turned ON. AGCONTIME is configured at &h22[6:4].

Default = 0

Select Address	Operation Description			
&h22 [6 : 4]	Command Value	Time	Command Value	Time
	0	0.5ms	4	3ms
	1	1ms	5	4ms
	2	1.5ms	6	5ms
	3	2ms	7	6ms