



Chipsmall Limited consists of a professional team with an average of over 10 year of expertise in the distribution of electronic components. Based in Hongkong, we have already established firm and mutual-benefit business relationships with customers from,Europe,America and south Asia,supplying obsolete and hard-to-find components to meet their specific needs.

With the principle of “Quality Parts,Customers Priority,Honest Operation,and Considerate Service”,our business mainly focus on the distribution of electronic components. Line cards we deal with include Microchip,ALPS,ROHM,Xilinx,Pulse,ON,Everlight and Freescale. Main products comprise IC,Modules,Potentiometer,IC Socket,Relay,Connector.Our parts cover such applications as commercial,industrial, and automotives areas.

We are looking forward to setting up business relationship with you and hope to provide you with the best service and solution. Let us make a better world for our industry!



Contact us

Tel: +86-755-8981 8866 Fax: +86-755-8427 6832

Email & Skype: info@chipsmall.com Web: www.chipsmall.com

Address: A1208, Overseas Decoration Building, #122 Zhenhua RD., Futian, Shenzhen, China



LCD Segment Drivers

Multi-function LCD Segment Drivers

BU97520AKV-M

MAX 276 Segment(69SEG x 4COM)

General Description

The BU97520AKV-M is 1/4 or 1/3-Duty general-purpose LCD driver that can be used for frequency display in electronic tuners under the control of a microcontroller. The BU97520AKV-M can drive up to 276 LCD Segments directly. The BU97520AKV-M can also control up to 6 general-purpose output ports. These products also incorporate a key scan circuit that accepts input from up to 30 keys to reduce printed circuit board wiring.

Features

- AEC-Q100 Qualified (Note1)
 - Key input function for up to 30 keys. (A key scan is performed only when a key is pressed.)
 - Either 1/4 or 1/3-Duty can be selected with the serial control data.
 - 1/4-Duty drive: Up to 276 segments
 - 1/3-Duty drive: Up to 207 segments
 - Serial data control of frame frequency for common and segment output waveforms.
 - Serial data control of switching between the segment output port, PWM output port and general-purpose output port functions.(Max 6 port)
 - Built-in OSC circuit
 - The INHb pin can force the display to the off state.
 - Integrated Power-on Reset circuit
 - No external component required
 - Low power consumption design
 - Supports Line and Frame Inversion
- (Note1) Grade 3

Applications

- Car audio, Home electrical appliance, Meter equipment etc.

Typical Application Circuit

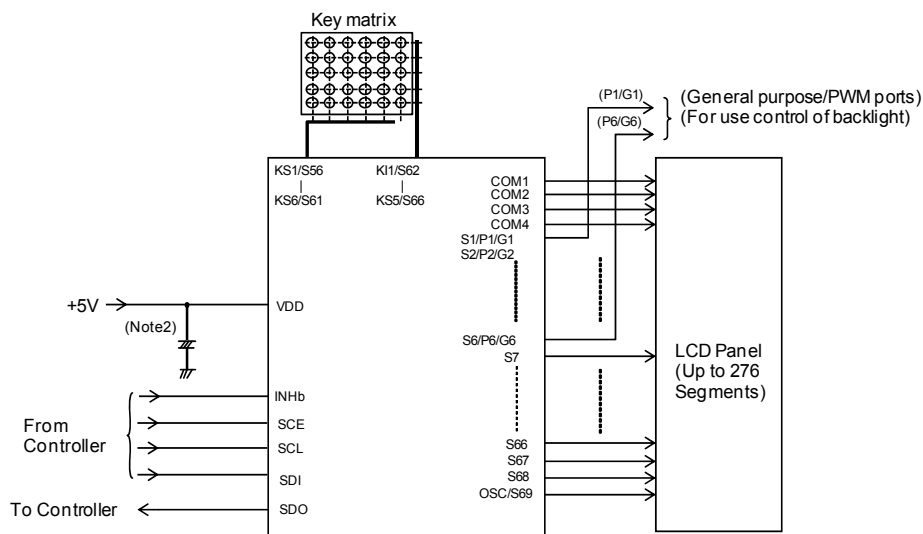

(Note2) Insert capacitors between VDD and VSS C > 0.1uF.

Figure 1. Typical Application Circuit

Key Specifications

- Supply Voltage Range: +2.7V to +6.0V
- Operating Temperature Range: -40°C to +85°C
- Max Segments: 276 Segments
- Display Duty: 1/3, 1/4 selectable
- Bias: 1/2, 1/3 selectable
- Interface: 3wire serial interface

Packages

VQFP80

W(Typ.)×D(Typ.)×H(Max.)



Block Diagram

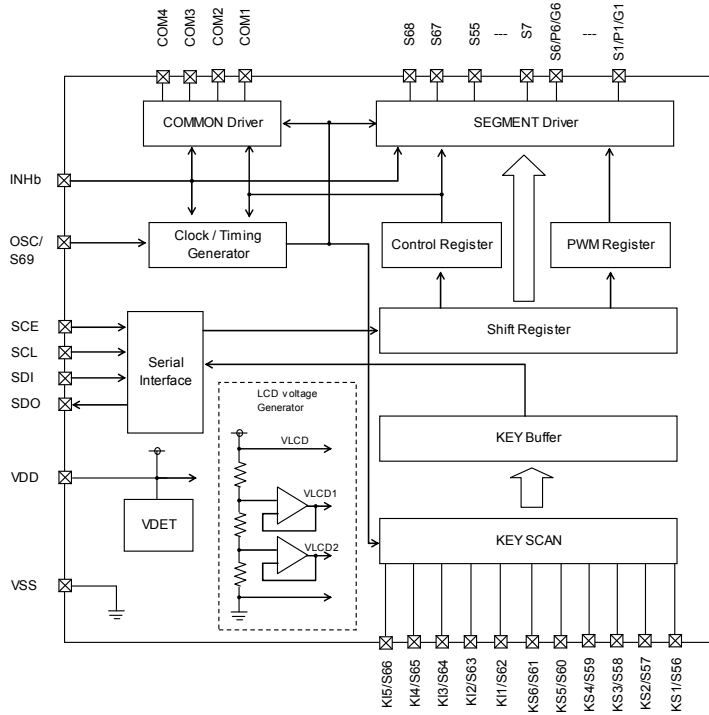

Figure 2. Block Diagram

Pin Configuration

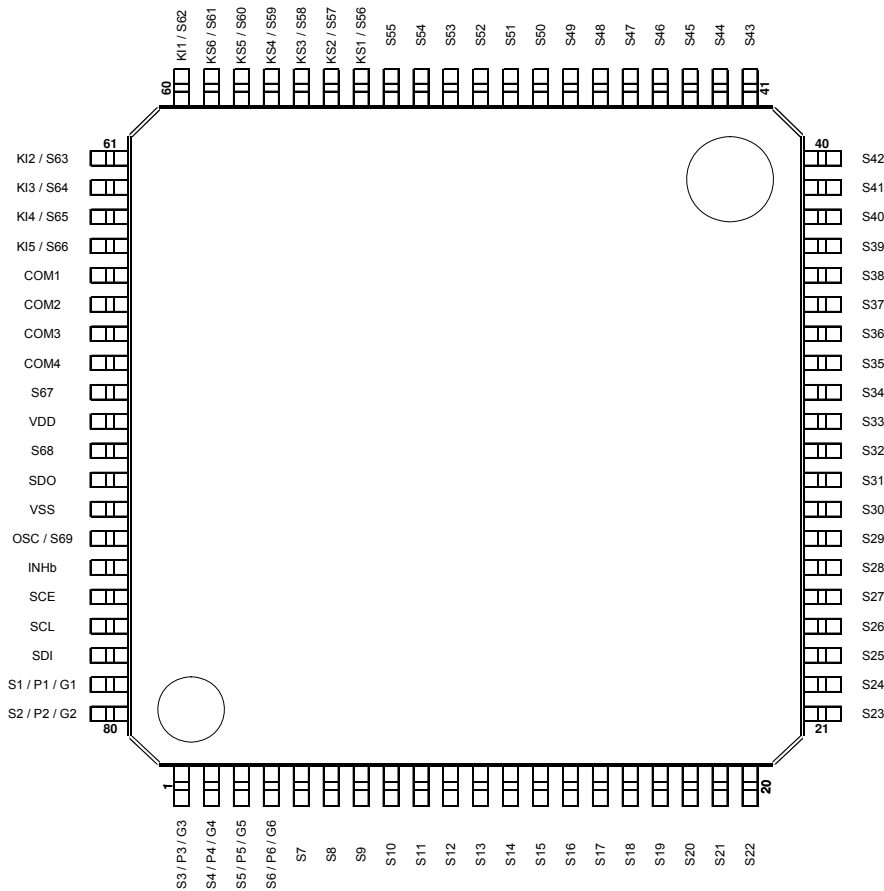

Figure 3. Pin Configuration (TOP VIEW)

Absolute Maximum Ratings (Ta = 25°C, VSS = 0V)

Parameter	Symbol	Conditions	Rating	Unit
Maximum Supply Voltage	VDD max	VDD	-0.3 to +6.5	V
Input Voltage	VIN1	SCE, SCL, SDI, INHb	-0.3 to +6.5	V
	VIN2	KI1 to KI5	-0.3 to +6.5	V
Allowable Loss	Pd		1.20 ^(Note3)	W
Operating Temperature	Topr		-40 to +85	°C
Storage Temperature	Tstg		-55 to +125	°C

(Note3) Derate by 12.0mW/°C when operating above Ta=25°C (when mounted in ROHM's standard board).

Caution: Operating the IC over the absolute maximum ratings may damage the IC. The damage can either be a short circuit between pins or an open circuit between pins and the internal circuitry. Therefore, it is important to consider circuit protection measures, such as adding a fuse, in case the IC is operated over the absolute maximum ratings.

Recommended Operating Conditions (Ta = -40°C to 85°C, VSS = 0V)

Parameter	Symbol	Conditions	Rating			Unit
			Min	Typ	Max	
Supply Voltage	VDD		2.7	5.0	6.0	V

Electrical Characteristics (Ta = -40°C to 85°C, VDD = 2.7V to 6.0V, VSS = 0V)

Parameter	Symbol	Pin	Conditions	Limit			Unit
				Min	Typ	Max	
Hysteresis	VH1	SCE, SCL, SDI, INHb		-	0.03VDD	-	V
	VH2	KI1 to KI5		-	0.1VDD	-	V
Power-on Detection Voltage	VDET	VDD		1.4	1.8	2.2	V
"H" Level Input Voltage	VIH1	SCE,SCL,SDI,INHb	4.0V ≤ VDD ≤ 6.0V	0.4VDD	-	VDD	V
	VIH2	SCE,SCL,SDI,INHb	2.7V ≤ VDD < 4.0V	0.8VDD	-	VDD	
	VIH3	KI1 to KI5		0.7VDD	-	VDD	
"L" Level Input Voltage	VIL1	SCE,SCL,SDI,INHb KI1 to KI5		0	-	0.2VDD	V
Input Floating Voltage	VIF	KI1 to KI5		-	-	0.05VDD	V
Pull-down Resistance	RPD	KI1 to KI5	VDD=5.0V	50	100	250	KΩ
Output Off Leakage Current	IOFFH	SDO	VO=6.0V	-	-	6.0	μA
"H" Level Input Current	IiH1	SCE,SCL,SDI,INHb	VI = 5.5V	-	-	5.0	μA
"L" Level Input Current	IiL1	SCE,SCL,SDI,INHb	VI = 0V	-5.0	-	-	μA
"H" Level Output Voltage	VOH1	S1 to S69	IO = -20μA	VDD-0.9	-	-	V
	VOH2	COM1 to COM4	IO = -100μA	VDD-0.9	-	-	
	VOH3	P1/G1 to P6/G6	IO = -1mA	VDD-0.9	-	-	
	VOH4	KS1 to KS6	IO = -500μA	VDD-1.0	VDD-0.5	VDD-0.2	
"L" Level Output Voltage	VOL1	S1 to S69	IO = 20μA	-	-	0.9	V
	VOL2	COM1 to COM4	IO = 100μA	-	-	0.9	
	VOL3	P1/G1 to P6/G6	IO = 1mA	-	-	0.9	
	VOL4	KS1 to KS6	IO = 25μA	0.2	0.5	1.5	
	VOL5	SDO	IO = 1mA	-	0.1	0.5	
Middle Level Output Voltage	VMID1	S1 to S69	1/2-Bias IO = ±20μA	1/2VDD -0.9	-	1/2VDD +0.9	V
	VMID2	COM1 to COM4	1/2-Bias IO = ±100μA	1/2VDD -0.9	-	1/2VDD +0.9	
	VMID3	S1 to S69	1/3-Bias IO = ±20μA	2/3VDD -0.9	-	2/3VDD +0.9	
	VMID4	S1 to S69	1/3-Bias IO = ±20μA	1/3VDD -0.9	-	1/3VDD +0.9	
	VMID5	COM1 to COM4	1/3-Bias IO = ±100μA	2/3VDD -0.9	-	2/3VDD +0.9	
	VMID6	COM1 to COM4	1/3-Bias IO = ±100μA	1/3VDD -0.9	-	1/3VDD +0.9	
Current Consumption	IDD1	VDD	Power-saving mode	-	-	15	μA
	IDD2	VDD	VDD = 5.0V Output open 1/2-Bias Frame frequency = 80Hz	-	85	170	
	IDD3	VDD	VDD = 5.0V Output open 1/3-Bias Frame frequency = 80Hz	-	110	210	

Oscillation Characteristics(Ta = -40°C to 85°C, VDD = 2.7V to 6.0V , VSS = 0V)

Parameter	Symbol	Pin	Conditions	Limit			Unit
				Min	Typ	Max	
Oscillator Frequency 1	fosc1	-	VDD = 2.7V to 6.0V	300	-	720	kHz
Oscillator Frequency 2	fosc2	-	VDD = 5V	510	600	690	kHz
External Clock Frequency (Note4)	fosc3	OSC	External clock mode (OC=1)	30	-	1000	kHz
External Clock Duty	tdty	OSC	External clock mode (OC=1)	30	50	70	%

(Note4) Frame frequency is decided by external frequency and dividing ratio of FC0, FC1, FC2 setting.

【Reference Data】

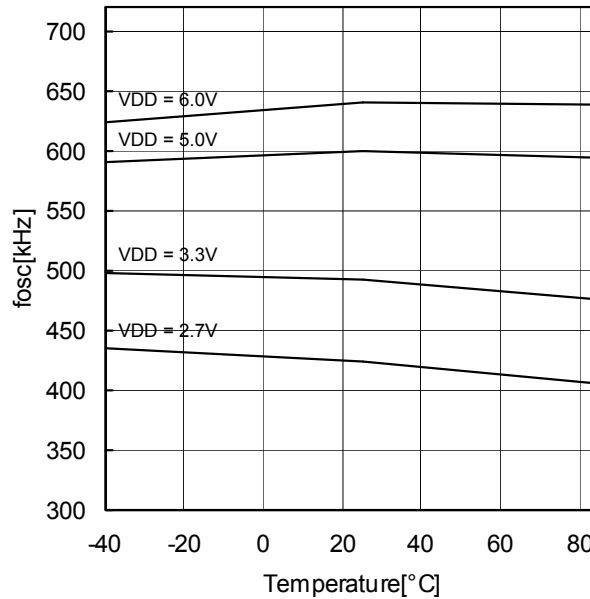

Figure 4. Typical Temperature Characteristics

MPU Interface Characteristics (Ta = -40°C to 85°C, VDD = 2.7V to 6.0V, VSS = 0V)

Parameter	Symbol	Pin	Conditions	Limit			Unit
				Min	Typ	Max	
Data Setup Time	tds	SCL, SDI		120	-	-	ns
Data Hold Time	tdh	SCL, SDI		120	-	-	ns
SCE Wait Time	tcp	SCE, SCL		120	-	-	ns
SCE Setup Time	tcs	SCE, SCL		120	-	-	ns
SCE Hold Time	tch	SCE, SCL		120	-	-	ns
Clock Cycle Time	tccyc	SCL		320	-	-	ns
High-level Clock Pulse Width	tchw	SCL		120	-	-	ns
Low-Level Clock Pulse Width (Write)	tclww	SCL		120	-	-	ns
Low-Level Clock Pulse Width (Read)	tclwr	SCL	RPU=4.7KΩ CL=10pF(Note5)	1.6	-	-	us
Rise Time	tr	SCE, SCL, SDI		-	160	-	ns
Fall Time	tf	SCE, SCL, SDI		-	160	-	ns
INH Switching Time	tc	INHb, SCE		10	-	-	μs
SDO Output Delay Time	tdc	SDO	RPU=4.7KΩ CL=10pF(Note5)	-	-	1.5	μs
SDO Rise Time	tdr	SDO	RPU=4.7KΩ CL=10pF(Note5)	-	-	1.5	μs

(Note5) Since SDO is an open-drain output, "tdc" and "tdr" depend on the resistance of the pull-up resistor RPU and the load capacitance SCL.

RPU: 1kΩ≤RPU≤10kΩ is recommended.

CL: A parasitic capacitance to VSS in an application circuit. Any component is not necessary to be attached.

Power supply for I/O level

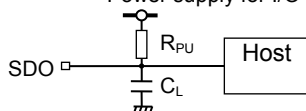

1. When SCL is stopped at the low level

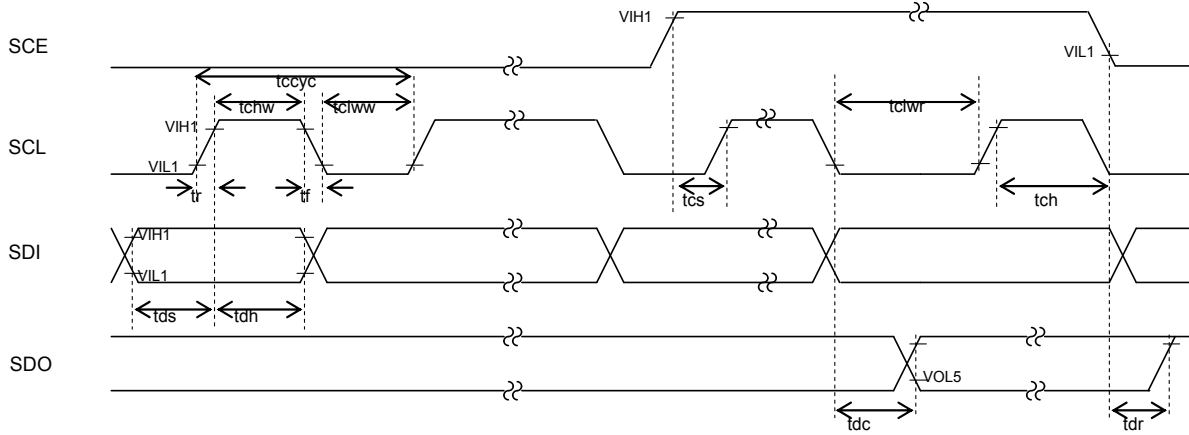

2. When SCL is stopped at the high level

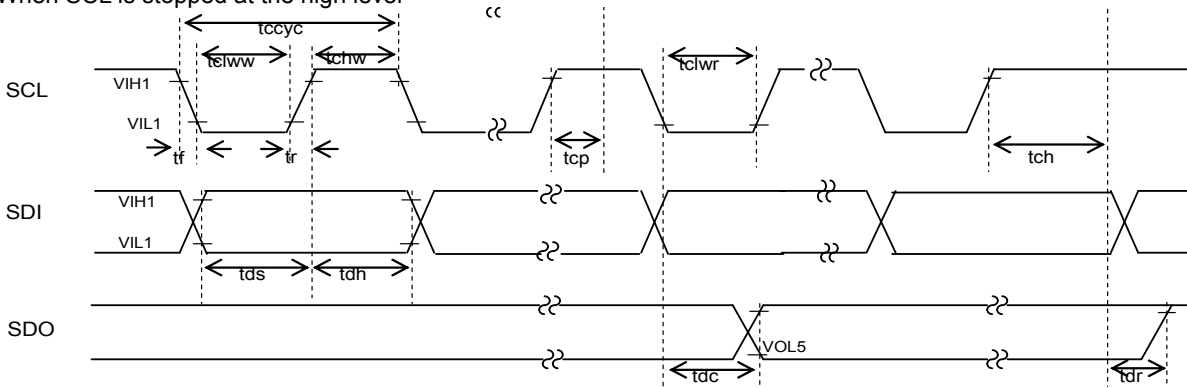

Figure 5. Serial Interface Timing

Pin Description

Symbol	Pin No.	Function	Active	I/O	Handling when unused
S1/P1/G1 to S6/P6/G6	79,80, 1 to 4,	Segment output for displaying the display data transferred by serial data input. The S1/P1/G1 to S6/P6/G6 pins can also be used as General-purpose outputs when so set up by the control data.	-	O	OPEN
S7 to S55 S67,S68	5 to 53, 69,71	Segment output for displaying the display data transferred by serial data input.	-	O	OPEN
KS1/S56 to KS6/S61	54 to 59	Key scan outputs Although normal key scan timing lines require diodes to be inserted in the timing lines to prevent shorts, since these outputs are unbalanced CMOS transistor outputs, these outputs will not be damaged by shorting when these outputs are used to form a key matrix. The KS1/S56 to KS6/S61 pins can be used as segment outputs when so specified by the control data.	-	O	OPEN
KI1/S62 to KI5/S66	60 to 64	Key scan inputs These pins have built-in pull-down resistors. The KI1/S62 to KI5/S66 pins can be used as segment outputs when so specified by the control data.	-	I/O	OPEN
COM1 to COM4	65 to 68	Common driver output pins. The frame frequency is f_o [Hz].	-	O	OPEN
S69/OSC	74	Segment output for displaying the display data transferred by serial data input. The pin S69/OSC can be used external frequency input pin when set up by the control data.	-	I/O	OPEN
SCE SCL SDI	76 77 78	Serial data transfer inputs. Must be connected to the controller. SCE: Chip enable SCL: Clock for serial data transfer. SDI: Transfer data	H - -	I I I	GND
SDO	72	Output data	-	O	OPEN

INHb	75	Display off control input. When INHb = low (VSS), Display forced off S1/P1/G1 to S6/P6/G6 = low (VSS) S7 to S69 = low (VSS) COM1 to COM4 = low (VSS) Stop the LCD drive bias voltage generation divider resistors. Stop the internal oscillation circuit. When INHb = high (VDD), Display on However, serial data transfer is possible when the display is forced off.	L	I	VDD
VDD	70	Power supply pin. A supply voltage of 2.7V to 6.0V must be applied to this pin.	-	-	-
VSS	73	Power supply pin. Must be connected to ground.	-	-	-

IO Equivalence Circuit

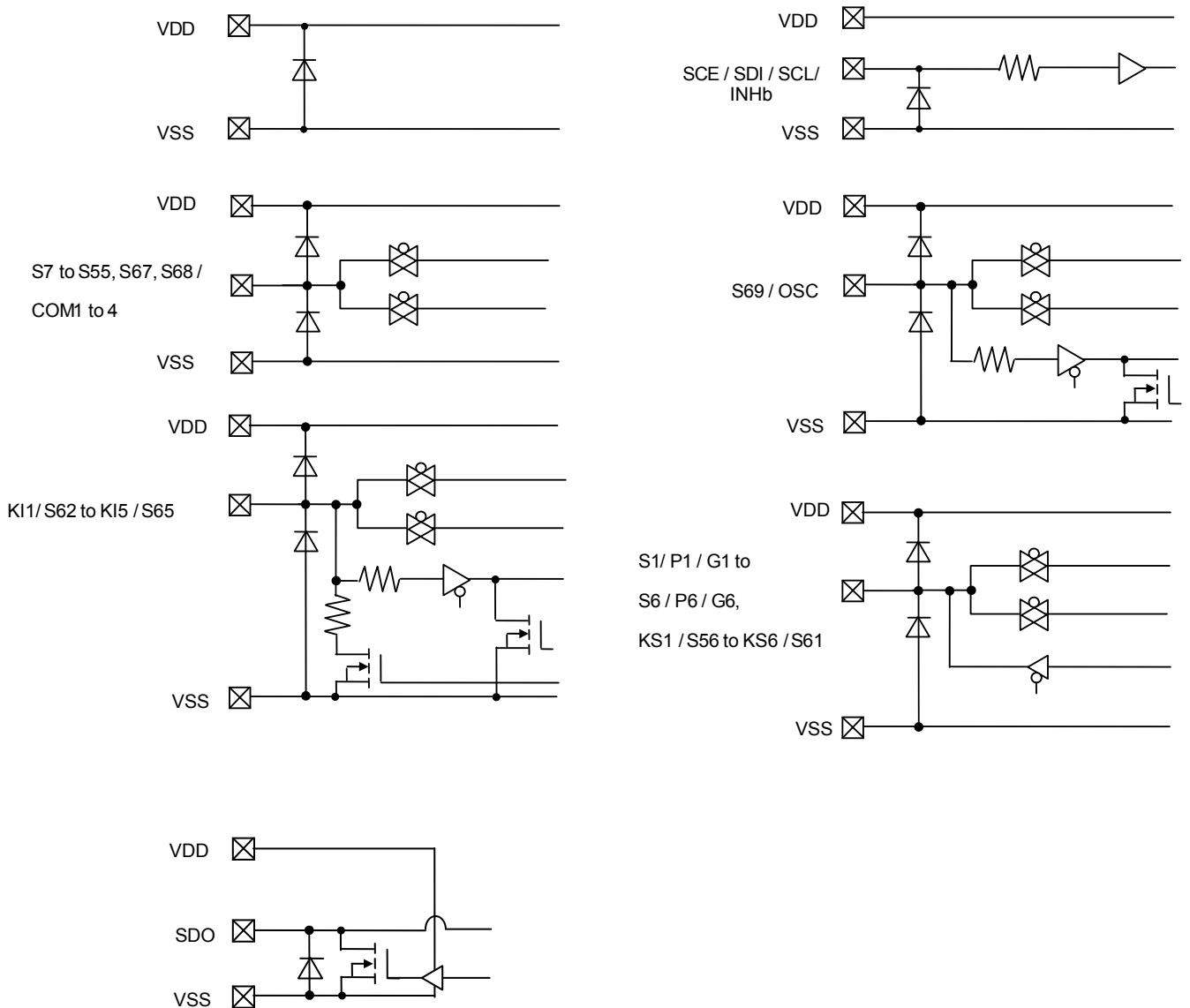

Figure 6. I/O Equivalence Circuit

Serial Data Transfer Formats

1. 1/4-Duty

17. When SCL is stopped at the low level

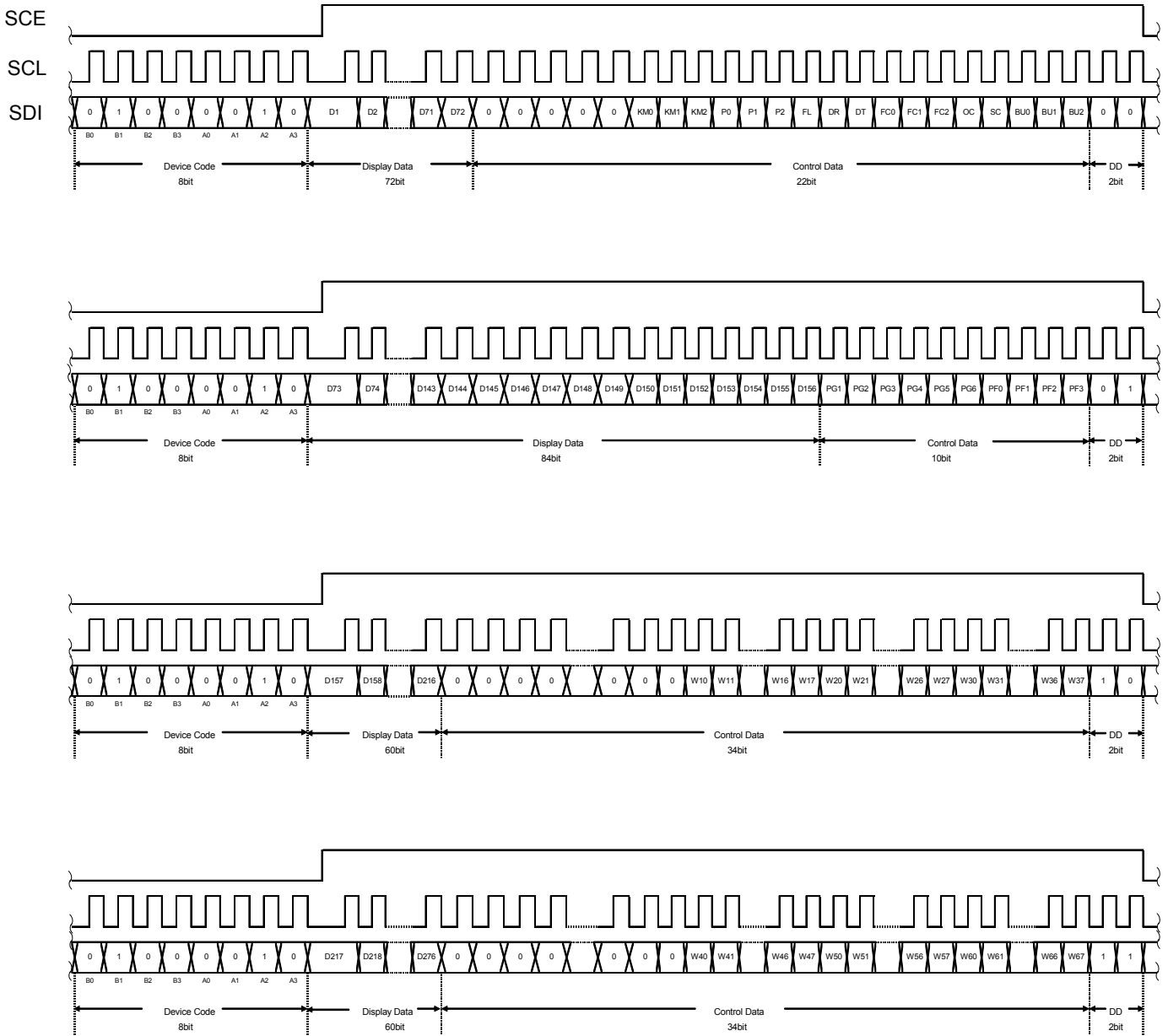

Figure 7. 3-SPI Data Transfer Format^(Note6)

(Note6) DD is direction data.

(2) When SCL is stopped at the high level

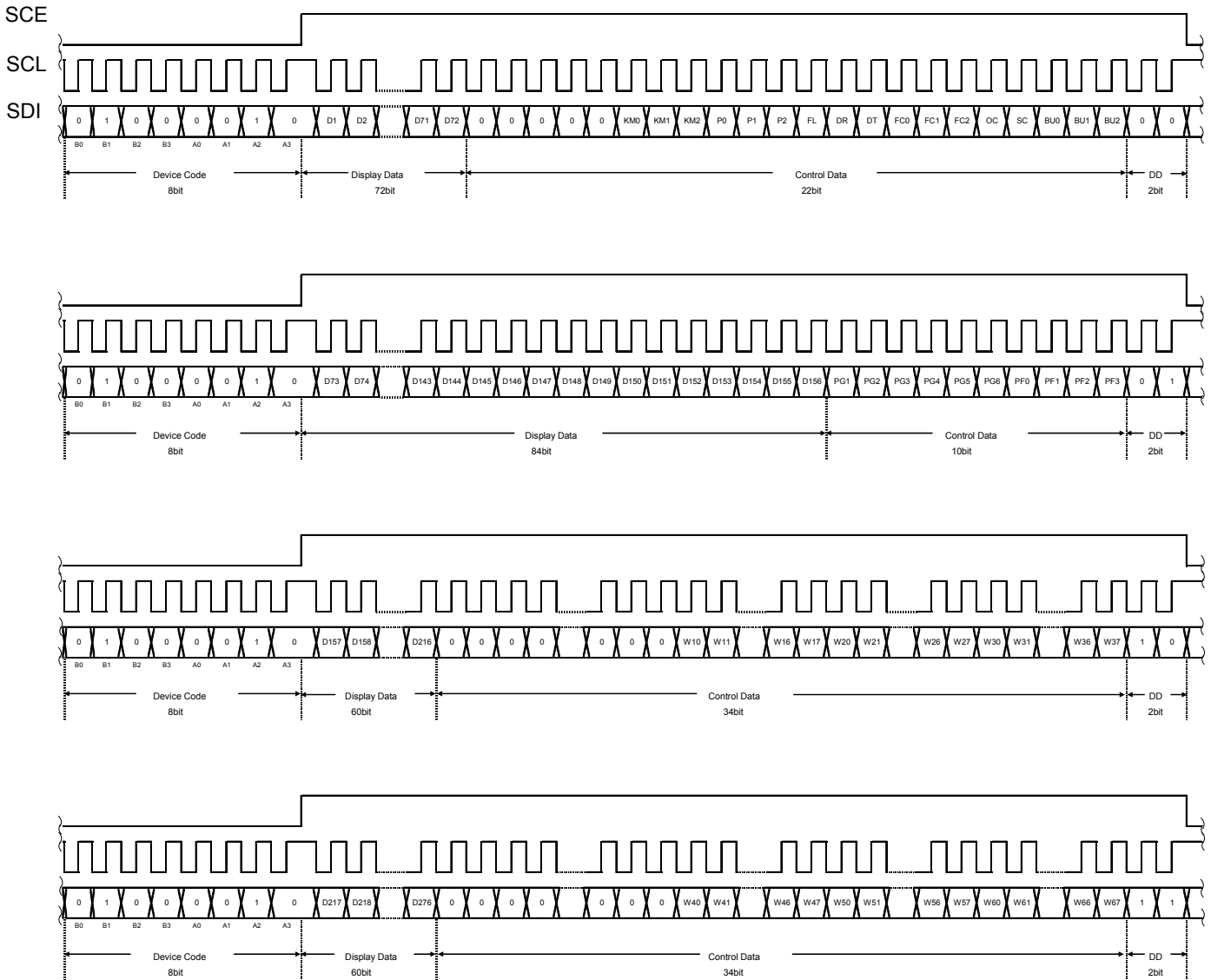

Figure 8. 3-SPI Data Transfer Format^(Note7)

(Note7) DD is direction data.

- Device code ----- "42H"
- D1 to D162 ----- Display data
- KM0 to KM2 ----- Key Scan output port/Segment output port switching control data
- P0 to P2 ----- Segment output port/general-purpose output port switching control data
- FL ----- Inversion type select control data
- DR ----- 1/3-Bias or 1/2-Bias drive switching control data
- DT ----- 1/4-Duty or 1/3-Duty drive switching control data
- FC0 to FC2 ----- Common/segment output waveform frame frequency setting control data
- OC ----- Internal oscillator operating mode/External clock operating mode switching control data
- SC ----- Segment on/off control data
- BU0 to BU2 ----- Normal mode/power-saving mode control data
- PG1 to PG6 ----- PWM/General Purpose output select data
- PF0 to PF3 ----- PWM output waveform frame frequency setting control data.
- Wn0 to Wn7 (n=1 to 6) ----- PWM output duty setting control data

2. 1/3-Duty

(1) When SCL is stopped at the low level

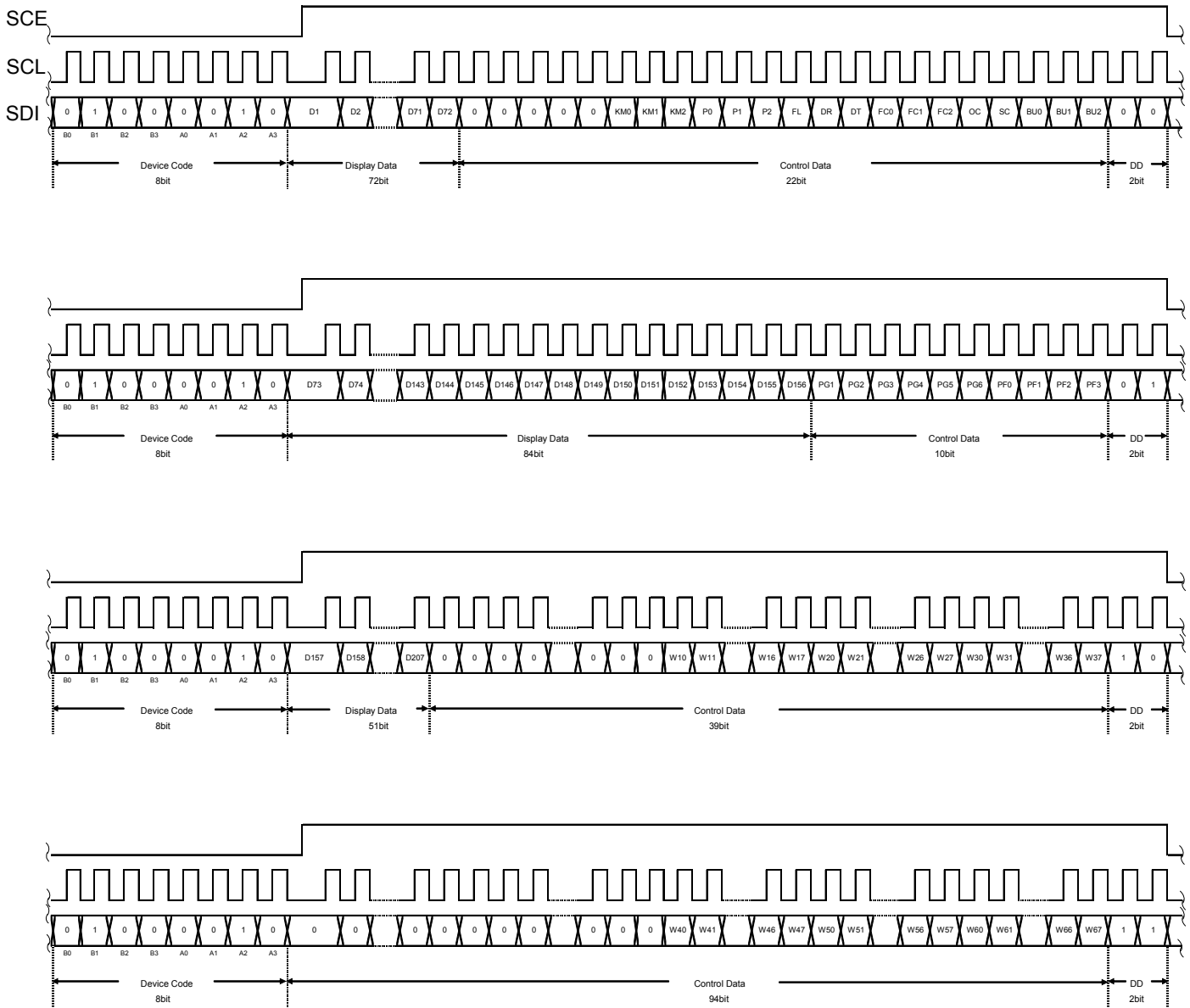

Figure 9. 3-SPI Data Transfer Format^(Note8)

(Note8) DD is direction data.

(2) When SCL is stopped at the high level

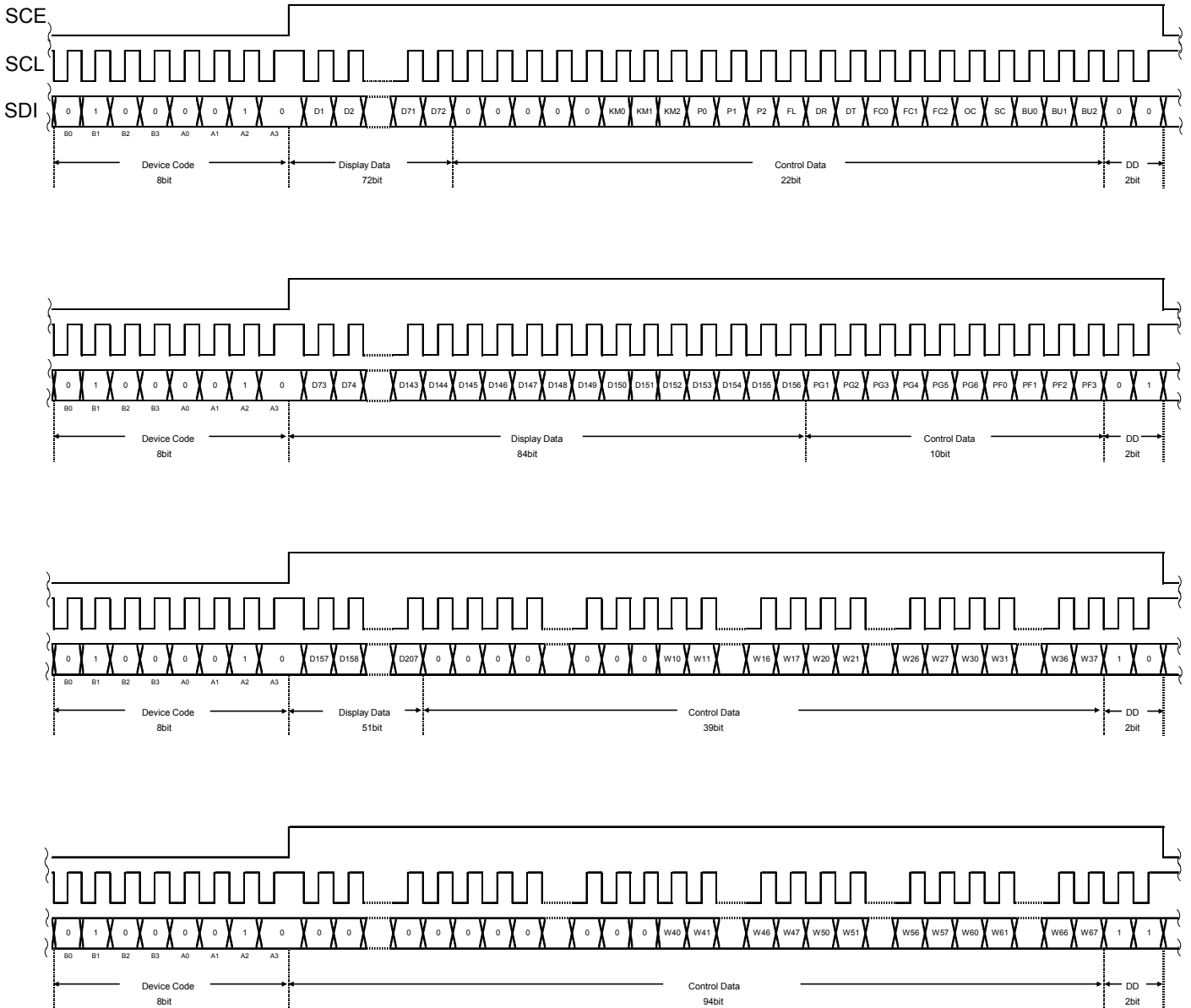

Figure 10. 3-SPI Data Transfer Format^(Note9)

(Note9) DD is direction data.

- Device code ----- "42H"
- D1 to D162 ----- Display data
- KM0 to KM2 ----- Key Scan output port/Segment output port switching control data
- P0 to P2 ----- Segment output port/general-purpose output port switching control data
- FL ----- Inversion type select control data
- DR ----- 1/3-Bias or 1/2-Bias drive switching control data
- DT ----- 1/4-Duty or 1/3-Duty drive switching control data
- FC0 to FC2 ----- Common/segment output waveform frame frequency setting control data
- OC ----- Internal oscillator operating mode/External clock operating mode switching control data
- SC ----- Segment on/off control data
- BU0 to BU2 ----- Normal mode/power-saving mode control data
- PG1 to PG6 ----- PWM/General Purpose output select data
- PF0 to PF3 ----- PWM output waveform frame frequency setting control data.
- Wn0 to Wn7 (n=1 to 6) ----- PWM output duty setting control data

Control Data Functions

17. KM0 to KM2: Key Scan output port/Segment output port control data

These control data bits switch the functions of the KS1/S56 to KS6/S61 output pins between key scan output and segment output.

KM0	KM1	KM2	Output Pin State						Maximum Number of Input keys
			KS1/S56	KS2/S57	KS3/S58	KS4/S59	KS5/S60	KS6/S61	
0	0	0	KS1	KS2	KS3	KS4	KS5	KS6	30
0	0	1	S56	KS2	KS3	KS4	KS5	KS6	25
0	1	0	S56	S57	KS3	KS4	KS5	KS6	20
0	1	1	S56	S57	S58	KS4	KS5	KS6	15
1	0	0	S56	S57	S58	S59	KS5	KS6	10
1	0	1	S56	S57	S58	S59	S60	KS6	5
1	1	0	S56	S57	S58	S59	S60	S61	0
1	1	1	S56	S57	S58	S59	S60	S61	0

2. P0 to P2: Segment / PWM / General Purpose output port control data

These control bits are used to select the function of the S1/P1 to S6/P6 output pins (Segment Output Pins or PWM Output Pins or General Purpose Output Pins).

P0	P1	P2	S1/P1/G1	S2/P2/G2	S3/P3/G3	S4/P4/G4	S5/P5/G5	S6/P6/G6
0	0	0	S1	S2	S3	S4	S5	S6
0	0	1	P1/G1	S2	S3	S4	S5	S6
0	1	0	P1/G1	P2/G2	S3	S4	S5	S6
0	1	1	P1/G1	P2/G2	P3/G3	S4	S5	S6
1	0	0	P1/G1	P2/G2	P3/G3	P4/G4	S5	S6
1	0	1	P1/G1	P2/G2	P3/G3	P4/G4	P5/G5	S6
1	1	0	P1/G1	P2/G2	P3/G3	P4/G4	P5/G5	P6/G6
1	1	1	S1	S2	S3	S4	S5	S6

PWM output or General Purpose output is selected by PGx (x=1 to 6) control data bit.

When the General Purpose Output Port Function is selected, the correspondence between the output pins and the respective display data is given in the table below.

Output Pins	Corresponding Display Data	
	1/4-Duty mode	1/3-Duty mode
S1/P1/G1	D1	D1
S2/P2/G2	D5	D4
S3/P3/G3	D9	D7
S4/P4/G4	D13	D10
S5/P5/G5	D17	D13
S6/P6/G6	D21	D16

When the General Purpose Output Port Function is selected, the respective output pin outputs a "HIGH" level when its corresponding display data is set to "1". Likewise, it will output a "LOW" level, if its corresponding display data is set to "0". For example, S4/P4/G4 is used as a General Purpose Output Port in case of 1/4-Duty, if its corresponding display data – D13 is set to "1", then S4/P4/G4 will output "HIGH" level. Likewise, if D13 is set to "0", then S4/P4/G4 will output "LOW" level.

3. DR: 1/3-Bias drive or 1/2-Bias drive control data

This control data bit selects either 1/3-Bias drive or 1/2-Bias drive.

DR	Bias Drive Scheme
0	1/3-Bias drive
1	1/2-Bias drive

4. FL: Line Inversion or Frame Inversion control data

This control data but selects either Line Inversion or Frame Inversion.

FL	Inversion Setting
0	Line
1	Frame

5. DT: 1/4-Duty drive or 1/3-Duty drive control data

This control data bit selects either 1/4-Duty drive or 1/3-Duty drive.

DT	Duty Drive Scheme
0	1/4-Duty drive
1	1/3-Duty drive

6. FC0, FC1, FC2: Common/segment output waveform frame frequency control data

These control data bits set the frame frequency for common and segment output waveforms.

FC0	FC1	FC2	Frame Frequency fo(Hz)
0	0	0	fosc ^(Note10) /12288
0	0	1	fosc/10752
0	1	0	fosc/9216
0	1	1	fosc/7680
1	0	0	fosc/6144
1	0	1	fosc/4608
1	1	0	fosc/3840
1	1	1	fosc/3072

(Note10) fosc: Internal oscillation frequency (600 [kHz] typ.)

7. OC: Internal oscillator operating mode/External clock operating mode control data

This control data bit selects the oscillation mode.

OC	Operating Mode	In/Out Pin(S69/OSC) Status
0	Internal oscillator	S69 (segment output)
1	External Clock	OSC (clock input)

8. SC: Segment on/off control data

This control data bit controls the on/off state of the segments.

SC	Display State
0	On
1	Off

Note that when the segments are turned off by setting SC to "1", the segments are turned off by outputting segment off waveforms from the segment output pins.

9. BU: Normal mode/power-saving mode control data

This control data bit selects either normal mode or power-saving mode.

BU0	BU1	BU2	Mode	OSC Oscillator	Segment outputs Common outputs	Output Pin States During Key Scan Standby					
						KS1	KS2	KS3	KS4	KS5	KS6
0	0	0	Normal	Operating	Operating	H	H	H	H	H	H
0	0	1				L	L	L	L	L	L
0	1	0	Power-saving	Stopped	Low(VSS)	L	L	L	L	H	H
0	1	1				L	L	L	H	H	H
1	0	0				L	L	H	H	H	H
1	0	1				L	H	H	H	H	H
1	1	0				H	H	H	H	H	H
1	1	1				H	H	H	H	H	H

Power-saving mode status:

S1/P1/G1 to S6/P6/G6 = active only General Purpose output

S7 to S69 = low(VSS)

COM1 to COM4 = low(VSS)

Stop the LCD drive bias voltage generation circuit

Stop the Internal oscillation circuit

However, serial data transfer is possible during Power-saving mode.

10. PG1, PG2, PG3, PG4, PG5, PG6: PWM/General Purpose output control data

This control data bit select either PWM output or General Purpose output of Sx/Px/Gx pins.(x=1 to 6)

PGx(x=1 to 6)	Mode
0	PWM output
1	General Purpose output

<PWM->GPO Changing function>

Normal behavior of changing GPO to PWM is below.

- PWM operation is started by command import timing of DD: 01 during GPO -> PWM change.
- Please take care of reflect timing of new duty setting of DD: 10 and DD: 11 is from the next PWM.

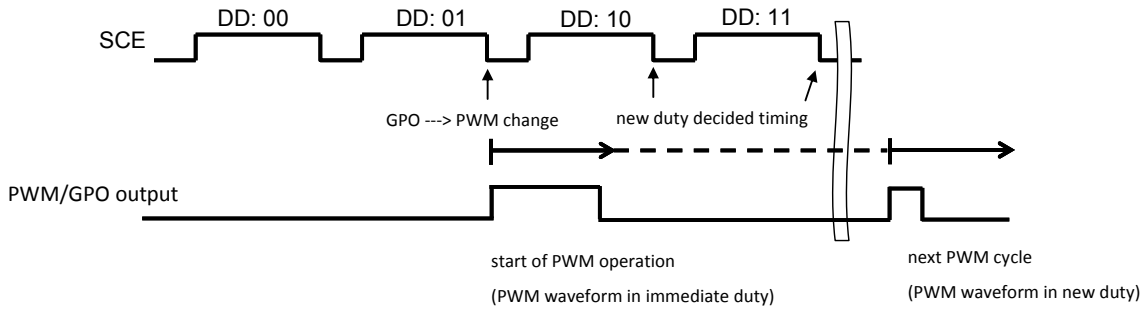

In order to avoid this operation, please input commands in reverse as below.

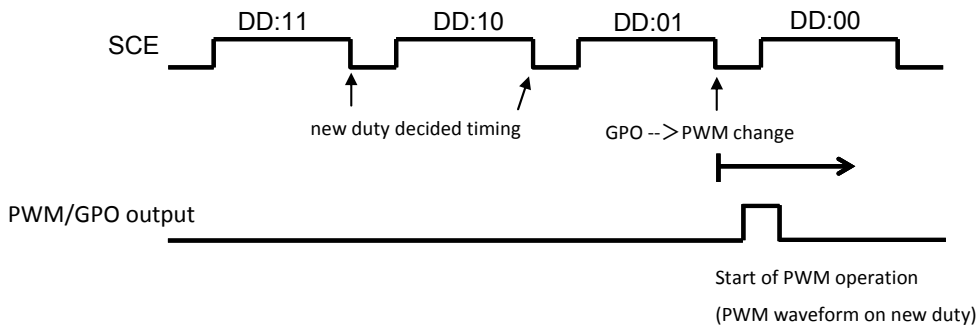

11. PF0, PF1, PF2, PF3: PWM output waveform frame frequency control data

These control data bits set the frame frequency for PWM output waveforms.

PF0	PF1	PF2	PF3	PWM output Frame Frequency fp(Hz)
0	0	0	0	fosc/4096
0	0	0	1	fosc/3840
0	0	1	0	fosc/3584
0	0	1	1	fosc/3328
0	1	0	0	fosc/3072
0	1	0	1	fosc/2816
0	1	1	0	fosc/2560
0	1	1	1	fosc/2304
1	0	0	0	fosc/2048
1	0	0	1	fosc/1792
1	0	1	0	fosc/1536
1	0	1	1	fosc/1280
1	1	0	0	fosc/1024
1	1	0	1	fosc/768
1	1	1	0	fosc/512
1	1	1	1	fosc/256

12. W10 to W17^(Note11), W20 to W27, W30 to W37, W40 to W47, W50 to W57, W60 to W67: PWM output waveform duty control data.

These control data bits set the high level pulse width(duty) for PWM output waveforms.

N = 1 to 6, $T_p = 1/f_p$

Wn0	Wn1	Wn2	Wn3	Wn4	Wn5	Wn6	Wn7	PWM Duty
0	0	0	0	0	0	0	0	(1/256) x T_p
0	0	0	0	0	0	0	1	(2/256) x T_p
0	0	0	0	0	0	1	0	(3/256) x T_p
0	0	0	0	0	0	1	1	(4/256) x T_p
0	0	0	0	0	1	0	0	(5/256) x T_p
0	0	0	0	0	1	0	1	(6/256) x T_p
0	0	0	0	0	1	1	0	(7/256) x T_p
0	0	0	0	0	1	1	1	(8/256) x T_p
0	0	0	0	1	0	0	0	(9/256) x T_p
0	0	0	0	1	0	0	1	(10/256) x T_p
0	0	0	0	1	0	1	0	(11/256) x T_p
0	0	0	0	1	0	1	1	(12/256) x T_p
0	0	0	0	1	1	0	0	(13/256) x T_p
0	0	0	0	1	1	0	1	(14/256) x T_p
0	0	0	0	1	1	1	0	(15/256) x T_p
0	0	0	0	1	1	1	1	(16/256) x T_p
0	0	0	1	0	0	0	0	(17/256) x T_p
0	0	0	1	0	0	0	1	(18/256) x T_p
0	0	0	1	0	0	1	0	(19/256) x T_p
0	0	0	1	0	0	1	1	(20/256) x T_p
0	0	0	1	0	1	0	0	(21/256) x T_p
0	0	0	1	0	1	0	1	(22/256) x T_p
0	0	0	1	0	1	1	0	(23/256) x T_p
0	0	0	1	0	1	1	1	(24/256) x T_p
0	0	0	1	1	0	0	0	(25/256) x T_p
0	0	0	1	1	0	0	1	(26/256) x T_p
0	0	0	1	1	0	1	0	(27/256) x T_p

1	1	1	0	0	1	0	1	(230/256) x T_p
1	1	1	0	0	1	1	0	(231/256) x T_p
1	1	1	0	0	1	1	1	(232/256) x T_p
1	1	1	0	1	0	0	0	(233/256) x T_p
1	1	1	0	1	0	0	1	(234/256) x T_p
1	1	1	0	1	0	1	0	(235/256) x T_p
1	1	1	0	1	0	1	1	(236/256) x T_p
1	1	1	0	1	1	0	0	(237/256) x T_p
1	1	1	0	1	1	0	1	(238/256) x T_p
1	1	1	0	1	1	1	0	(239/256) x T_p
1	1	1	0	1	1	1	1	(240/256) x T_p
1	1	1	1	0	0	0	0	(241/256) x T_p
1	1	1	1	0	0	0	1	(242/256) x T_p
1	1	1	1	0	0	1	0	(243/256) x T_p
1	1	1	1	0	0	1	1	(244/256) x T_p
1	1	1	1	0	1	0	0	(245/256) x T_p
1	1	1	1	0	1	0	1	(246/256) x T_p
1	1	1	1	0	1	1	0	(247/256) x T_p
1	1	1	1	0	1	1	1	(248/256) x T_p
1	1	1	1	1	0	0	0	(249/256) x T_p
1	1	1	1	1	0	0	1	(250/256) x T_p
1	1	1	1	1	0	1	0	(251/256) x T_p
1	1	1	1	1	0	1	1	(252/256) x T_p
1	1	1	1	1	1	0	0	(253/256) x T_p
1	1	1	1	1	1	0	1	(254/256) x T_p
1	1	1	1	1	1	1	0	(255/256) x T_p
1	1	1	1	1	1	1	1	(256/256) x T_p

(Note11):W10 to W17:S1/P1/G1 PWM duty data
 W20 to W27:S2/P2/G2 PWM duty data
 W30 to W37:S3/P3/G3 PWM duty data
 W40 to W47:S4/P4/G4 PWM duty data
 W50 to W57:S5/P5/G5 PWM duty data
 W60 to W67:S6/P6/G6 PWM duty data

Display Data and Output Pin Correspondence

17. 1/4-Duty

Output Pin ^(Note12)	COM1	COM2	COM3	COM4
S1/P1/G1	D1	D2	D3	D4
S2/P2/G2	D5	D6	D7	D8
S3/P3/G3	D9	D10	D11	D12
S4/P4/G4	D13	D14	D15	D16
S5/P5/G5	D17	D18	D19	D20
S6/P6/G6	D21	D22	D23	D24
S7	D25	D26	D27	D28
S8	D29	D30	D31	D32
S9	D33	D34	D35	D36
S10	D37	D38	D39	D40
S11	D41	D42	D43	D44
S12	D45	D46	D47	D48
S13	D49	D50	D51	D52
S14	D53	D54	D55	D56
S15	D57	D58	D59	D60
S16	D61	D62	D63	D64
S17	D65	D66	D67	D68
S18	D69	D70	D71	D72
S19	D73	D74	D75	D76
S20	D77	D78	D79	D80
S21	D81	D82	D83	D84
S22	D85	D86	D87	D88
S23	D89	D90	D91	D92
S24	D93	D94	D95	D96
S25	D97	D98	D99	D100
S26	D101	D102	D103	D104
S27	D105	D106	D107	D108
S28	D109	D110	D111	D112
S29	D113	D114	D115	D116
S30	D117	D118	D119	D120
S31	D121	D122	D123	D124
S32	D125	D126	D127	D128
S33	D129	D130	D131	D132
S34	D133	D134	D135	D136
S35	D137	D138	D139	D140
S36	D141	D142	D143	D144
S37	D145	D146	D147	D148
S38	D149	D150	D151	D152
S39	D153	D154	D155	D156
S40	D157	D158	D159	D160
S41	D161	D162	D163	D164
S42	D165	D166	D167	D168
S43	D169	D170	D171	D172
S44	D173	D174	D175	D176
S45	D177	D178	D179	D180
S46	D181	D182	D183	D184
S47	D185	D186	D187	D188
S48	D189	D190	D191	D192
S49	D193	D194	D195	D196
S50	D197	D198	D199	D200
S51	D201	D202	D203	D204
S52	D205	D206	D207	D208
S53	D209	D210	D211	D212
S54	D213	D214	D215	D216
S55	D217	D218	D219	D220
S56	D221	D222	D223	D224
S57	D225	D226	D227	D228
S58	D229	D230	D231	D232
S59	D233	D234	D235	D236
S60	D237	D238	D239	D240
S61	D241	D242	D243	D244
S62	D245	D246	D247	D248
S63	D249	D250	D251	D252

Output pin ^(Note12)	COM1	COM2	COM3	COM4
S64	D253	D254	D255	D256
S65	D257	D258	D259	D260
S66	D261	D262	D263	D264
S67	D265	D266	D267	D268
S68	D269	D270	D271	D272
S69	D273	D274	D275	D276

(Note12) The Segment Output Port function is assumed to be selected for the output pins – S1/P1/G1 to S6/P6/G6.

To illustrate further, the states of the S21 output pin is given in the table below.

Display Data				State of S21 Output Pin
D81	D82	D83	D84	
0	0	0	0	LCD Segments corresponding to COM1 to COM4 are OFF.
0	0	0	1	LCD Segment corresponding to COM4 is ON.
0	0	1	0	LCD Segment corresponding to COM3 is ON.
0	0	1	1	LCD Segments corresponding to COM3 and COM4 are ON.
0	1	0	0	LCD Segment corresponding to COM2 is ON.
0	1	0	1	LCD Segments corresponding to COM2 and COM4 are ON.
0	1	1	0	LCD Segments corresponding to COM2 and COM3 are ON.
0	1	1	1	LCD Segments corresponding to COM2, COM3 and COM4 are ON.
1	0	0	0	LCD Segment corresponding to COM1 is ON.
1	0	0	1	LCD Segments corresponding to COM1 and COM4 are ON.
1	0	1	0	LCD Segments corresponding to COM1 and COM3 are ON.
1	0	1	1	LCD Segments corresponding to COM1, COM3 and COM4 are ON.
1	1	0	0	LCD Segments corresponding to COM1 and COM2 are ON.
1	1	0	1	LCD Segments corresponding to COM1, COM2, and COM4 are ON.
1	1	1	0	LCD Segments corresponding to COM1, COM2, and COM3 are ON.
1	1	1	1	LCD Segments corresponding to COM1 to COM 4 are ON.

2. 1/3-Duty

Output Pin ^(Note13)	COM1	COM2	COM3
S1/P1/G1	D1	D2	D3
S2/P2/G2	D4	D5	D6
S3/P3/G3	D7	D8	D9
S4/P4/G4	D10	D11	D12
S5/P5/G5	D13	D14	D15
S6/P6/G6	D16	D17	D18
S7	D19	D20	D21
S8	D22	D23	D24
S9	D25	D26	D27
S10	D28	D29	D30
S11	D31	D32	D33
S12	D34	D35	D36
S13	D37	D38	D39
S14	D40	D41	D42
S15	D43	D44	D45
S16	D46	D47	D48
S17	D49	D50	D51
S18	D52	D53	D54
S19	D55	D56	D57
S20	D58	D59	D60
S21	D61	D62	D63
S22	D64	D65	D66
S23	D67	D68	D69
S24	D70	D71	D72
S25	D73	D74	D75
S26	D76	D77	D78
S27	D79	D80	D81
S28	D82	D83	D84
S29	D85	D85	D87
S30	D88	D89	D90
S31	D91	D92	D93
S32	D94	D95	D96
S33	D97	D98	D99
S34	D100	D101	D102
S35	D103	D104	D105
S36	D106	D107	D108
S37	D109	D110	D111
S38	D112	D113	D114
S39	D115	D116	D117
S40	D118	D119	D120
S41	D121	D122	D123
S42	D124	D125	D126
S43	D127	D128	D129
S44	D130	D131	D132
S45	D133	D134	D135
S46	D136	D137	D138
S47	D139	D140	D141
S48	D142	D143	D144
S49	D145	D146	D147
S50	D148	D149	D150
S51	D151	D152	D153
S52	D154	D155	D156
S53	D157	D158	D159
S54	D160	D161	D162
S55	D163	D164	D165
S56	D166	D167	D168
S57	D169	D170	D171
S58	D172	D173	D174
S59	D175	D176	D177
S60	D178	D179	D180
S61	D181	D182	D183
S62	D184	D185	D186
S63	D187	D188	D189

Output pin ^(Note13)	COM1	COM2	COM3
S64	D190	D191	D192
S65	D193	D194	D195
S66	D196	D197	D198
S67	D199	D200	D201
S68	D202	D203	D204
S69	D205	D206	D207

(Note13) The Segment Output Port function is assumed to be selected for the output pins – S1/P1/G1 to S6/P6/G6.

To illustrate further, the states of the S21 output pin is given in the table below.

Display Data			State of S21 Output Pin
D61	D62	D63	
0	0	0	LCD Segments corresponding to COM1, COM2 and COM3 are OFF.
0	0	1	LCD Segment corresponding to COM3 is ON.
0	1	0	LCD Segment corresponding to COM2 is ON.
0	1	1	LCD Segments corresponding to COM2 and COM3 are ON.
1	0	0	LCD Segment corresponding to COM1 is ON.
1	0	1	LCD Segments corresponding to COM1 and COM3 are ON.
1	1	0	LCD Segments corresponding to COM1 and COM2 are ON.
1	1	1	LCD Segments corresponding to COM1, COM2 and COM3 are ON.

Serial Data Output

17. When SCL is stopped at the low level^(Note14)

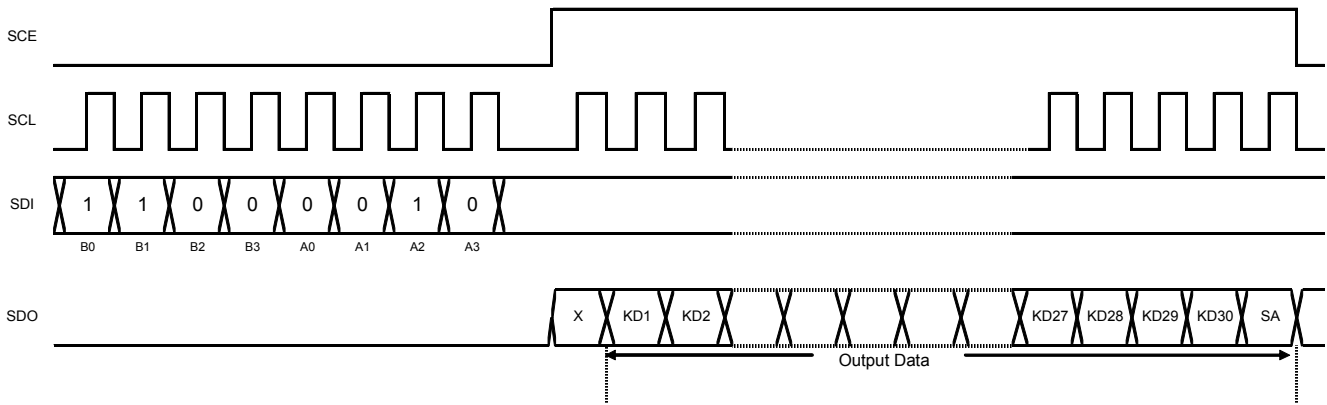

Figure 11. Serial data output format

(Note14)

- 1. X=Don't care
- 2. B0 to B3, A0 to A3: Serial Interface address

2. When SCL is stopped at the high level^(Note15)

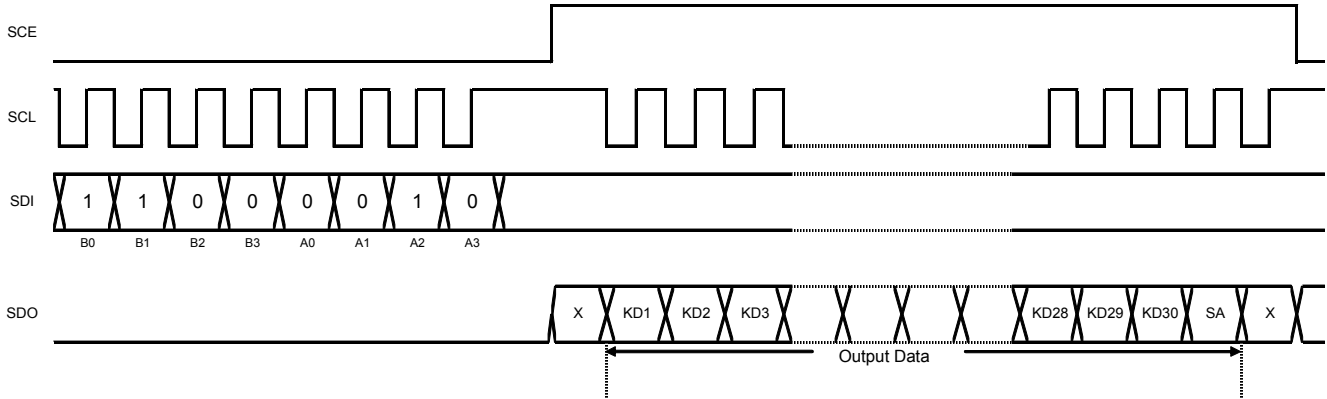

Figure 12. Serial Data Output Format

(Note15)

- 1. X=Don't care
- 2. B0 to B3, A0 to A3: Serial Interface address
- 3. Serial Interface address: 43H
- 4. KD1 to KD30: Key data
- 5. SA: Sleep acknowledge data
- 6. If a key data read operation is executed when SDO is high, the read key data (KD1 to KD30) and sleep acknowledge data (SA) will be invalid.

Output Data

17. KD1 to KD30: KEY DATA

When a key matrix of up to 30 keys is formed from the KS1 to KS6 output pins and the KI1 to KI5 input pins and one of those keys is pressed, the key output data corresponding to that key will be set to 1. The table shows the relationship between those pins and the key data bits.

Item	KI1	KI2	KI3	KI4	KI5
KS1	KD1	KD2	KD3	KD4	KD5
KS2	KD6	KD7	KD8	KD9	KD10
KS3	KD11	KD12	KD13	KD14	KD15
KS4	KD16	KD17	KD18	KD19	KD20
KS5	KD21	KD22	KD23	KD24	KD25
KS6	KD26	KD27	KD28	KD29	KD30

2. SA: Sleep Acknowledge Data

This output data is set to the state when the key was pressed. In that case SDO will go to the low level. If serial data is input during this period and the mode is set (normal mode or sleep mode), the IC will be set to that mode. SA is set to 1 in the sleep mode and to 0 in the normal mode.

Sleep Mode

Sleep mode is set up by setting the BU0 to BU2 in the control data to 1. The segment outputs will all go low and the common outputs will also go low, and the oscillator on the OSC pin will stop (it will be started by a key press). This reduces power dissipation. This mode is cleared by sending control data with all the BU0 to BU2 set to 0. However, note that the S1/P1/G1 to S6/P6/G6 outputs can be used as general-purpose output ports according to the state of the P0 to P2 control data bits, even in sleep mode. (See the control data description for details.)

Key Scan Operation Function

17. Key Scan Timing

The key scan period is 4608T(s). To reliably determine the on/off state of the keys, the BU97520AKV-M scans the keys twice and determines that a key has been pressed when the key data agrees. It outputs a key data read request (a low level on SDO) 9840T(s) after starting a key scan. If the key data does not agree and a key was pressed at that point, it scans the keys again. Thus the BU97520AKV-M cannot detect a key press shorter than 9840T(s).

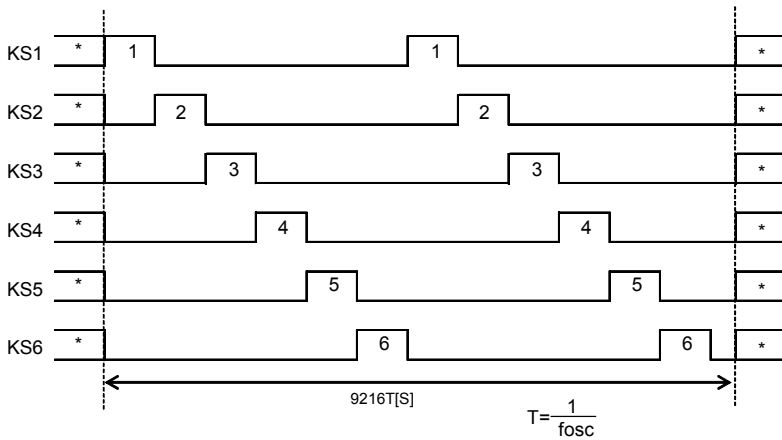

Figure 13. Key Scan Timing^(Note16)

(Note16) *: In sleep mode the high/low state of these pins is determined by the BU0 to BU2 bits in the control data. Key scan output signals are not output from pins that are set "L".

2. In Normal Mode

The pins KS1 to KS6 are set "H".

When a key is pressed a key scan is started and the keys are scanned until all keys are released. Multiple key presses are recognized by determining whether multiple key data bits are set.

If a key is pressed for longer than 9840T(s) (Where $T=1/fosc$) the BU97520AKV-M outputs a key data read request (a low level on SDO) to the controller. The controller acknowledges this request and reads the key data. However, if SCE is high during a serial data transfer, SDO will be set "H".

After the controller reads the key data, the key data read request is cleared (SDO is set high) and the BU97520AKV-M performs another key scan. Also note that SDO, being an open-drain output, requires a pull-up resistor (between 1 KΩ and 10KΩ).

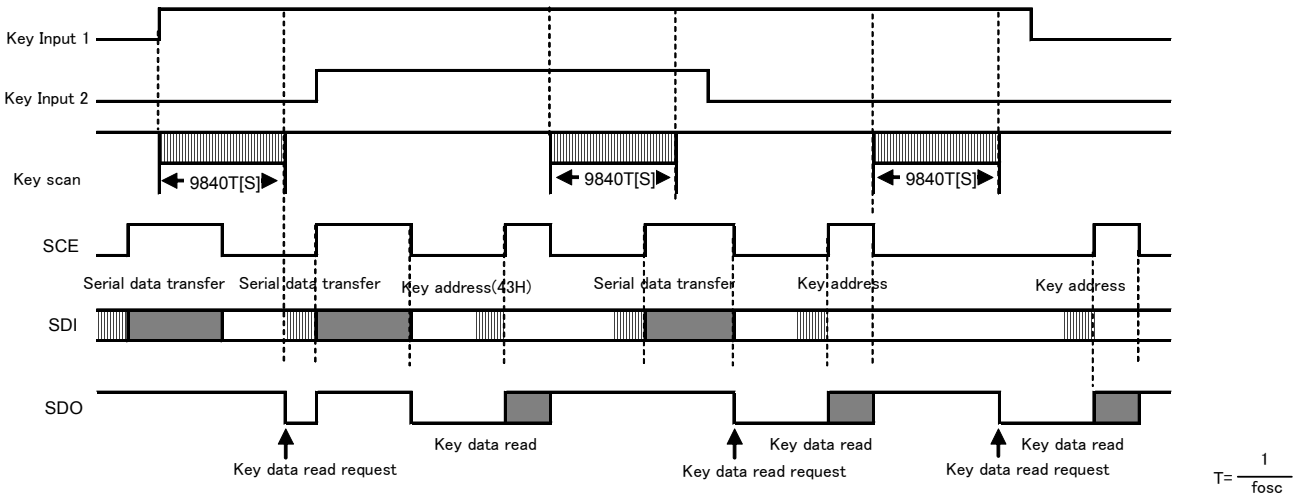

Figure 14. Key Scan Operation In Normal Mode

3. In Sleep Mode

The pins KS1 to KS6 are set to high or low by the BU0 to BU2 bits in the control data. (See the control data description for details.)

If a key on one of the lines corresponding to a KS1 to KS6 pin which is set high is pressed, the oscillator on the OSC pin is started and a key scan is performed. Keys are scanned until all keys are released. Multiple key presses are recognized by determining whether multiple key data bits are set.

If a key is pressed for longer than 9840T(s)(Where $T=1/f_{osc}$) the BU97520AKV-M outputs a key data read request (a low level on SDO) to the controller. The controller acknowledges this request and reads the key data. However, if SCE is high during a serial data transfer, SDO will be set high.

After the controller reads the key data, the key data read request is cleared (SDO is set high) and the BU97520AKV-M performs another key scan. Also note that SDO, being an open-drain output, requires a pull-up resistor (between 1 and 10KΩ).

Sleep mode key scan example

Example: BU0=0, BU1=0, BU2=1 (sleep with only KS6 high)

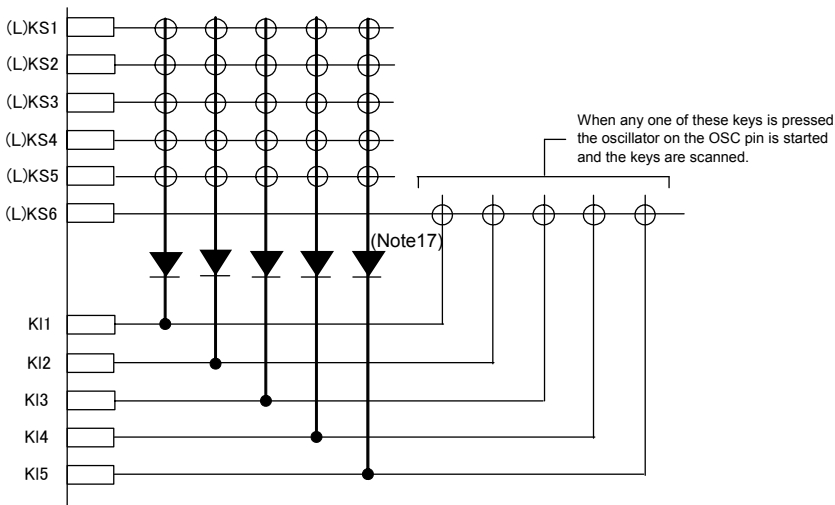

(Note17)

These diodes are required to reliably recognize multiple key presses on the KS6 line when sleep mode state with only KS6 high, as in the above example. That is, these diodes prevent incorrect operations due to sneak currents in the KS6 key scan output signal when keys on the KS1 to KS5 lines are pressed at the same time.

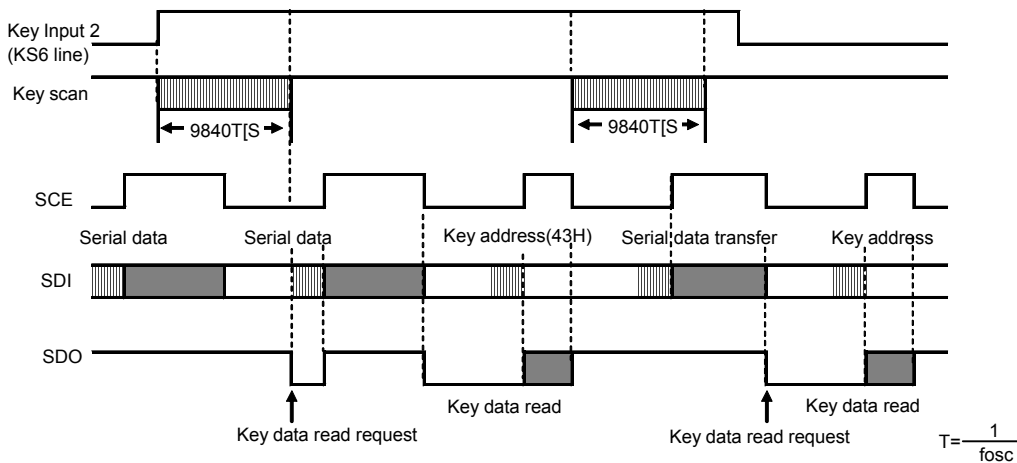

Figure 15. Key Scan Operation In Sleep Mode

Multiple Key Press

Although the BU97520AKV-M is capable of key scanning without inserting diodes for dual key presses, triple key presses on the KI1 to KI5 input pin lines, or multiple key presses on the KS1 to KS6 output pin lines, multiple presses other than these cases may result in keys that were not pressed recognized as having been pressed. Therefore, a diode must be inserted in series with each key. Applications that do not recognize multiple key presses of three or more keys should check the key data for three or more 1 bit and ignore such data.

Controller Key Data Read Technique

When the controller receives a key data read request from BU97520AKV-M, it performs a key data read acquisition operation using either the Timer Based Key Data Acquisition or the Interrupt Based Key Data Acquisition.

Timer Based Key Data Acquisition Technique

Under the Timer Based Key Data Acquisition Technique, the controller uses a timer to determine the states of the keys (ON or OFF) and read the key data. Please refer to the flowchart below.

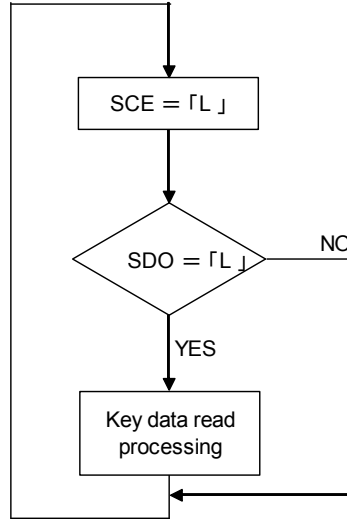

Key data read processing: Refer to “Serial Data Output”

Figure 16. Flowchart

In this technique, the controller uses a timer to determine key on/off states and read the key data. The controller must check the SDO state when SCE is low every t_7 period without fail. If SDO is low, the controller recognizes that a key has been pressed and executes the key data read operation.

The period t_7 in this technique must satisfy the following condition.
 $T_7 > t_4 + t_5 + t_6$

If a key data read operation is executed when SDO is high, the read key data (KD1 to KD30) and sleep acknowledge data (SA) will be invalid.

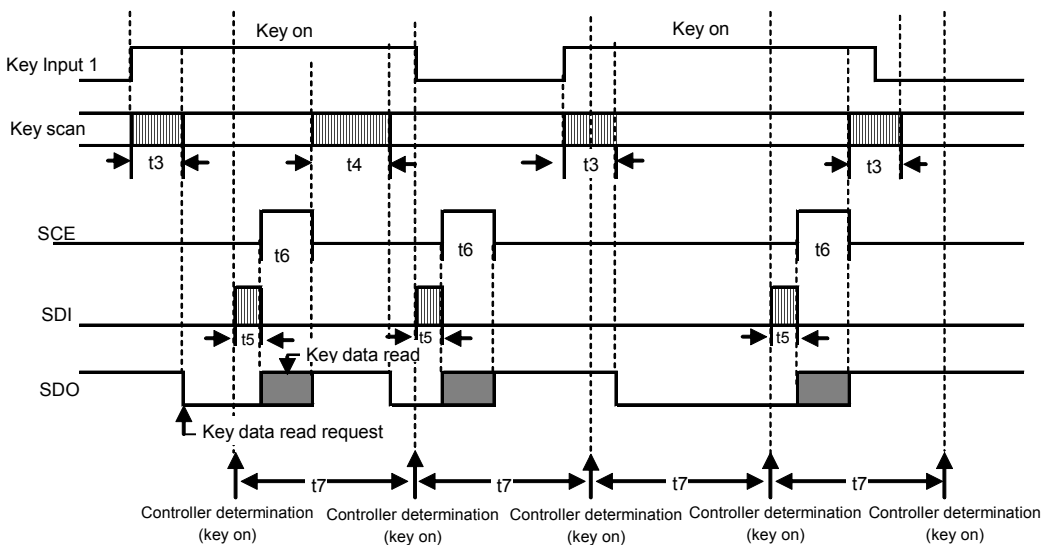

- t_3 : Key scan execution time when the key data agreed for two key scans. (9840T(s))
- t_4 : Key scan execution time when the key data did not agree for two key scans and the key scan was executed again. (19680T(s)) $T = 1 / f_{osc}$
- t_5 : Key address (43H) transfer time
- t_6 : Key data read time

Figure 17. Timer Based Key Data Read Operation

Interrupt Based Key Data Acquisition Technique

Under the Interrupt Based Key Data Acquisition Technique, the controller uses interrupts to determine the state of the keys (ON or OFF) and read the key data. Please refer to the flow chart diagram below.

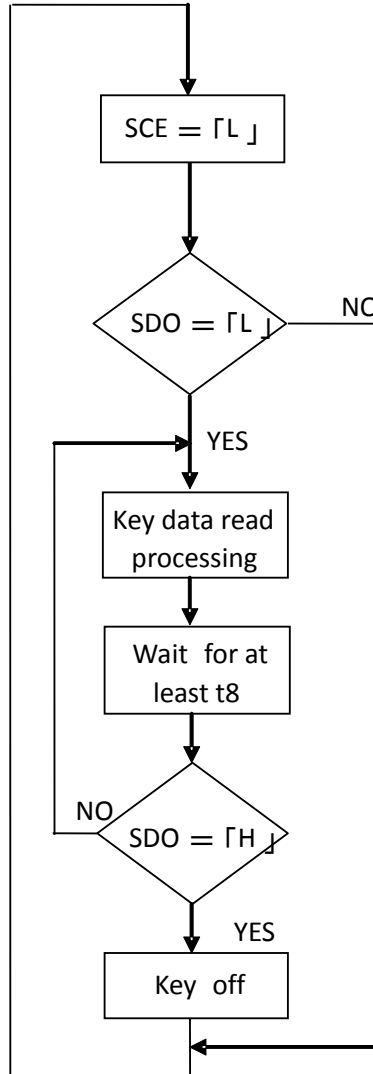

Key data read processing: Refer to “Serial Data Output”

Figure 18. Flowchart

In this technique, the controller uses interrupts to determine key on/off states and read the key data. The controller must check the SDO state when SCE is low. If SDO is low, the controller recognizes that a key has been pressed and executes the key data read operation. After that the next key on/off determination is performed after the time t_8 has elapsed by checking the SDO state when SCE is low and reading the key data. The period t_8 in this technique must satisfy $t_8 > t_4$.

If a key data read operation is executed when SDO is high, the read key data (KD1 to KD30) and sleep acknowledge data (SA) will be invalid.

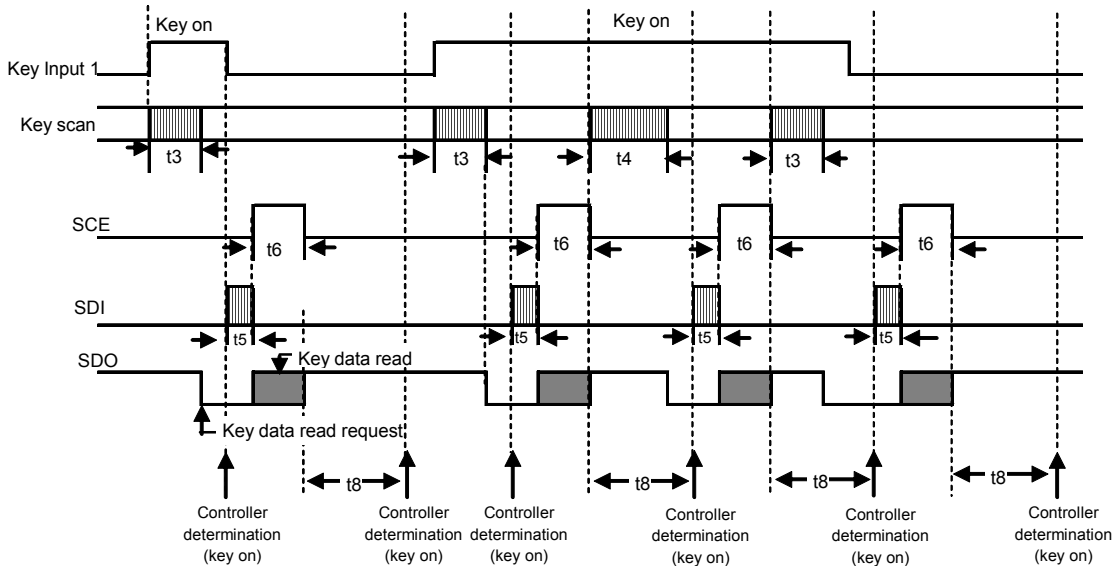

- t3: Key scan execution time when the key data agreed for two key scans. (9840T(s))
- t4: Key scan execution time when the key data did not agree for two key scans and the key scan was executed again. (19680T(s)) $T = 1 / f_{osc}$
- t5: Key address (43H) transfer time
- t6: Key data read time

Figure 19. Interrupt Based Key Data Read Operation