



Chipsmall Limited consists of a professional team with an average of over 10 year of expertise in the distribution of electronic components. Based in Hongkong, we have already established firm and mutual-benefit business relationships with customers from,Europe,America and south Asia,supplying obsolete and hard-to-find components to meet their specific needs.

With the principle of “Quality Parts,Customers Priority,Honest Operation,and Considerate Service”,our business mainly focus on the distribution of electronic components. Line cards we deal with include Microchip,ALPS,ROHM,Xilinx,Pulse,ON,Everlight and Freescale. Main products comprise IC,Modules,Potentiometer,IC Socket,Relay,Connector.Our parts cover such applications as commercial,industrial, and automotives areas.

We are looking forward to setting up business relationship with you and hope to provide you with the best service and solution. Let us make a better world for our industry!



Contact us

Tel: +86-755-8981 8866 Fax: +86-755-8427 6832

Email & Skype: info@chipsmall.com Web: www.chipsmall.com

Address: A1208, Overseas Decoration Building, #122 Zhenhua RD., Futian, Shenzhen, China





BUL742A

HIGH VOLTAGE FAST-SWITCHING NPN POWER TRANSISTOR

- HIGH VOLTAGE CAPABILITY
- LOW SPREAD OF DYNAMIC PARAMETERS
- MINIMUM LOT-TO-LOT SPREAD FOR RELIABLE OPERATION
- VERY HIGH SWITCHING SPEED

APPLICATIONS

- FOUR LAMP ELECTRONIC BALLAST FOR:
120 V MAINS IN PUSH-PULL
CONFIGURATION;
277 V MAINS IN HALF BRIDGE CURRENT
FEED CONFIGURATION.
- SWITCH MODE POWER SUPPLIES

DESCRIPTION

The BUL742A is manufactured using high voltage Multi Epitaxial Planar technology for high switching speeds and high voltage capability.

Thanks to an increased intermediate layer, it has an intrinsic ruggedness which enables the transistor to withstand an high collector current level during breakdown condition, without using the transil protection usually necessary in typical converters for lamp ballast.

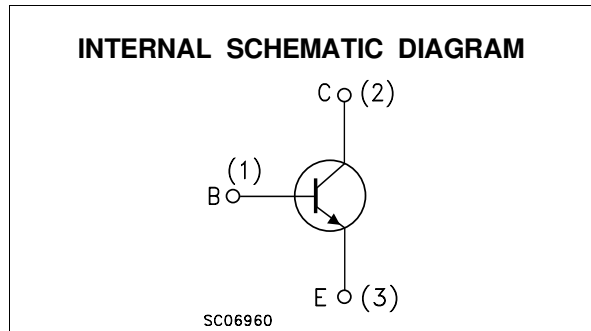
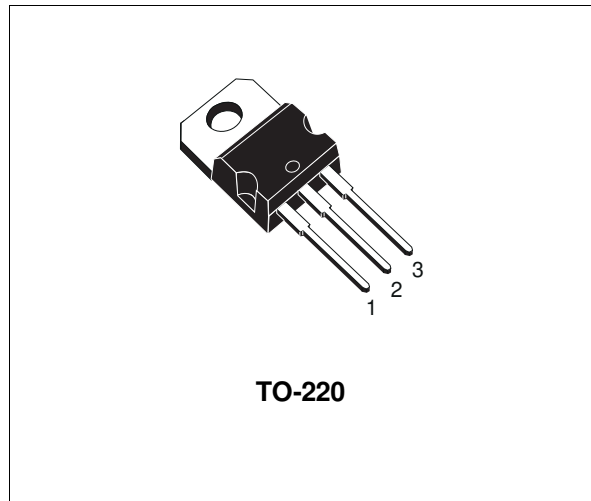

ABSOLUTE MAXIMUM RATINGS

Symbol	Parameter	Value	Unit
V_{CES}	Collector-Emitter Voltage ($V_{BE} = 0$)	950	V
V_{CEO}	Collector-Emitter Voltage ($I_B = 0$)	400	V
V_{EBO}	Emitter-Base Voltage ($I_C = 0$, $I_B \leq 2$ A, $t_p < 10\mu s$, $T_j < 150^\circ C$)	$V_{(BR)EBO}$	V
I_C	Collector Current	4	A
I_{CM}	Collector Peak Current ($t_p < 5$ ms)	8	A
I_B	Base Current	2	A
I_{BM}	Base Peak Current ($t_p < 5$ ms)	4	A
P_{tot}	Total Dissipation at $T_c = 25^\circ C$	70	W
T_{stg}	Storage Temperature	-65 to 150	$^\circ C$
T_j	Max. Operating Junction Temperature	150	$^\circ C$

BUL742A

THERMAL DATA

R _{thj-case}	Thermal Resistance Junction-Case	Max	1.78	°C/W
R _{thj-amb}	Thermal Resistance Junction-Ambient	Max	62.5	°C/W

ELECTRICAL CHARACTERISTICS (T_{case} = 25 °C unless otherwise specified)

Symbol	Parameter	Test Conditions		Min.	Typ.	Max.	Unit
I _{CES}	Collector Cut-off Current (V _{BE} = 0)	V _{CE} = 950 V				100	μA
I _{CEO}	Collector Cut-off Current (I _B = 0)	V _{CE} = 400 V				250	μA
V _{CEO(sus)*}	Collector-Emitter Sustaining Voltage (I _B = 0)	I _C = 10 mA	L = 25 mH	400			V
V _{(BR)EBO}	Emitter-Base Breakdown Voltage (I _C = 0)	I _E = 1 mA		12		24	V
V _{CE(sat)*}	Collector-Emitter Saturation Voltage	I _C = 1 A I _C = 3.5 A	I _B = 0.2 A I _B = 1 A			0.5 1.5	V V
V _{BE(sat)*}	Base-Emitter Saturation Voltage	I _C = 3.5 A	I _B = 1 A			1.5	V
h _{FE} *	DC Current Gain	I _C = 800 mA I _C = 10 mA	V _{CE} = 3 V V _{CE} = 5 V	16 10		40	
t _s t _f	RESISTIVE LOAD Storage Time Fall Time	V _{CC} = 250 V I _{B1} = 0.5 A t _p = 30 μs	I _C = 2.5 A I _{B2} = -1 A (see figure 2)		0.9 100		μs ns
E _{sb}	Avalanche Energy	L = 2 mH	(see figure 1)	6			mJ

* Pulsed: Pulse duration = 300 μs, duty cycle 1.5 %

Safe Operating Areas

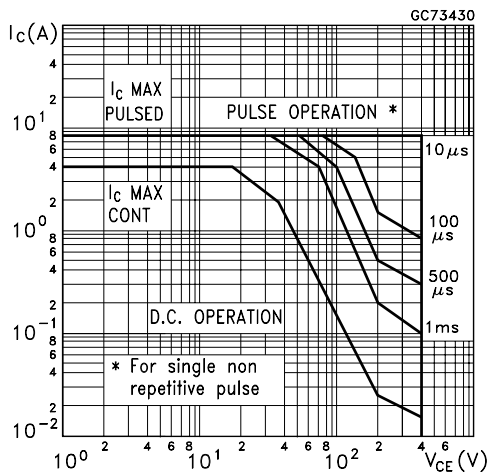

Derating Curve

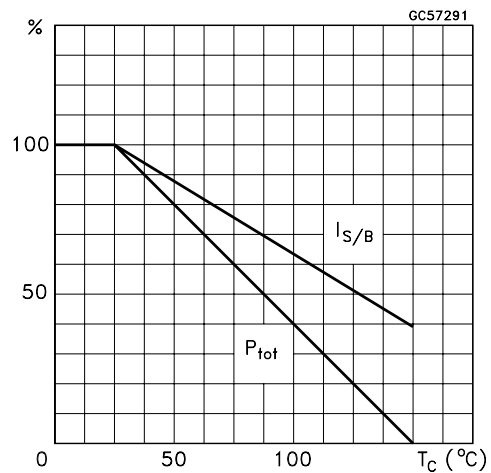

Figure 1: Energy Rating Test Circuit

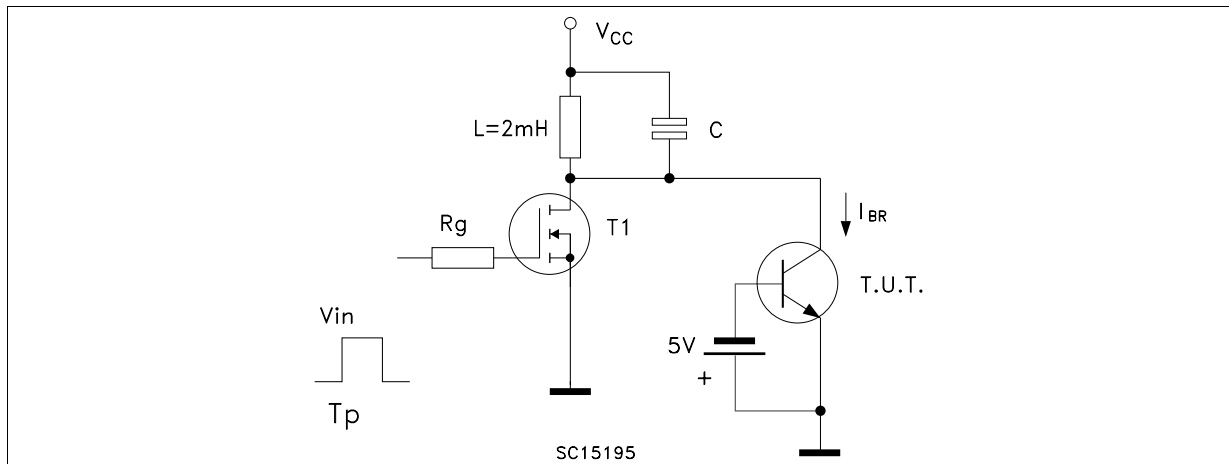
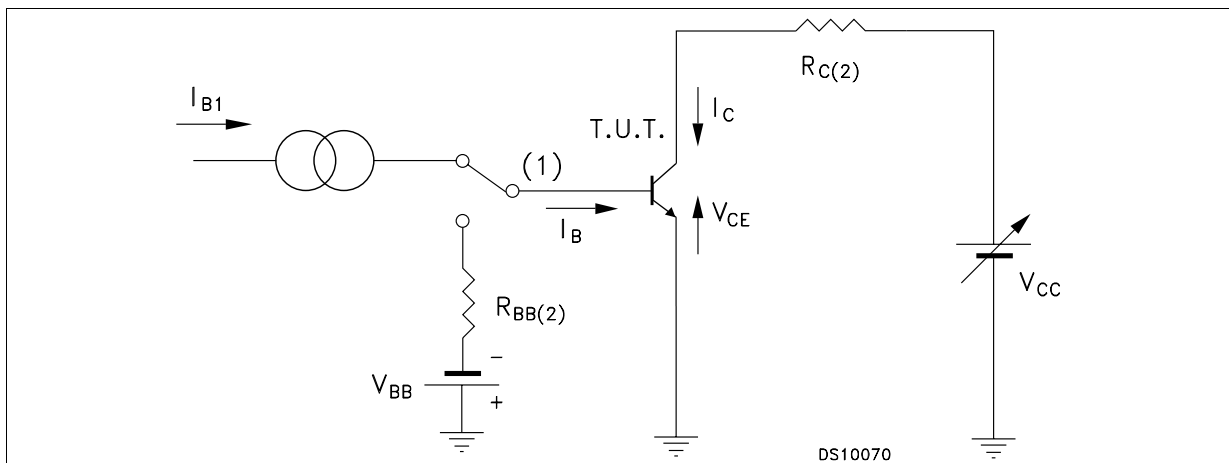
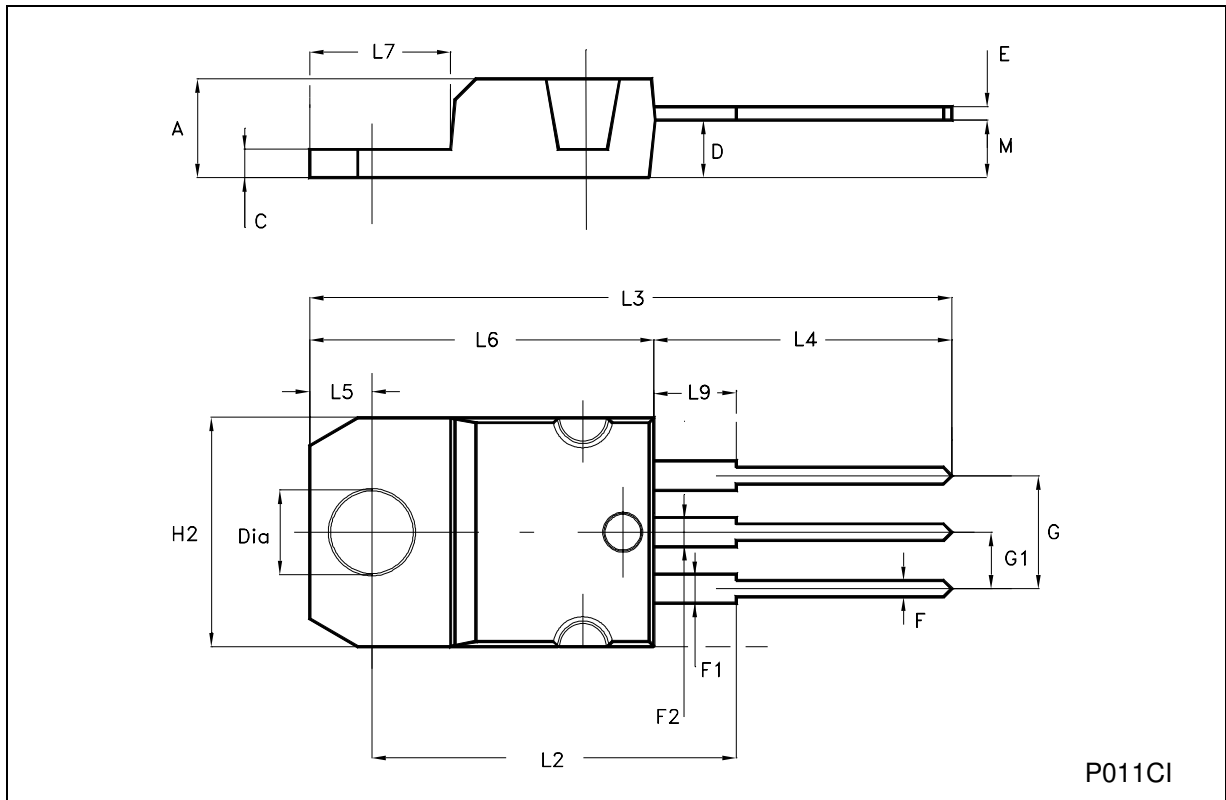

Figure 2: Resistive Load Switching Test Circuit



TO-220 MECHANICAL DATA

DIM.	mm			inch		
	MIN.	TYP.	MAX.	MIN.	TYP.	MAX.
A	4.40		4.60	0.173		0.181
C	1.23		1.32	0.048		0.052
D	2.40		2.72	0.094		0.107
E	0.49		0.70	0.019		0.027
F	0.61		0.88	0.024		0.034
F1	1.14		1.70	0.044		0.067
F2	1.14		1.70	0.044		0.067
G	4.95		5.15	0.194		0.202
G1	2.40		2.70	0.094		0.106
H2	10.00		10.40	0.394		0.409
L2		16.40			0.645	
L4	13.00		14.00	0.511		0.551
L5	2.65		2.95	0.104		0.116
L6	15.25		15.75	0.600		0.620
L7	6.20		6.60	0.244		0.260
L9	3.50		3.93	0.137		0.154
M		2.60			0.102	
DIA.	3.75		3.85	0.147		0.151



P011CI

Information furnished is believed to be accurate and reliable. However, STMicroelectronics assumes no responsibility for the consequences of use of such information nor for any infringement of patents or other rights of third parties which may result from its use. No license is granted by implication or otherwise under any patent or patent rights of STMicroelectronics. Specification mentioned in this publication are subject to change without notice. This publication supersedes and replaces all information previously supplied. STMicroelectronics products are not authorized for use as critical components in life support devices or systems without express written approval of STMicroelectronics.

The ST logo is a trademark of STMicroelectronics.

All other names are the property of their respective owners.

© 2003 STMicroelectronics – All Rights reserved

STMicroelectronics GROUP OF COMPANIES

Australia - Belgium - Brazil - Canada - China - Czech Republic - Finland - France - Germany - Hong Kong - India - Israel - Italy - Japan - Malaysia - Malta - Morocco - Singapore - Spain - Sweden - Switzerland - United Kingdom - United States.

<http://www.st.com>