



Chipsmall Limited consists of a professional team with an average of over 10 year of expertise in the distribution of electronic components. Based in Hongkong, we have already established firm and mutual-benefit business relationships with customers from,Europe,America and south Asia,supplying obsolete and hard-to-find components to meet their specific needs.

With the principle of “Quality Parts,Customers Priority,Honest Operation,and Considerate Service”,our business mainly focus on the distribution of electronic components. Line cards we deal with include Microchip,ALPS,ROHM,Xilinx,Pulse,ON,Everlight and Freescale. Main products comprise IC,Modules,Potentiometer,IC Socket,Relay,Connector.Our parts cover such applications as commercial,industrial, and automotives areas.

We are looking forward to setting up business relationship with you and hope to provide you with the best service and solution. Let us make a better world for our industry!



Contact us

Tel: +86-755-8981 8866 Fax: +86-755-8427 6832

Email & Skype: info@chipsmall.com Web: www.chipsmall.com

Address: A1208, Overseas Decoration Building, #122 Zhenhua RD., Futian, Shenzhen, China





BUT70W

HIGH POWER NPN TRANSISTOR

- STMicroelectronics PREFERRED SALESTYPE
- NPN TRANSISTOR
- HIGH CURRENT CAPABILITY
- FAST SWITCHING SPEED
- VERY LOW SATURATION VOLTAGE AND HIGH GAIN

APPLICATION

- SWITCHING REGULATORS
- MOTOR CONTROL
- HIGH FREQUENCY AND EFFICIENCY CONVERTERS

DESCRIPTION

The BUT70W is a Multiepitaxial planar NPN transistor in TO-247 plastic package.

It's intended for use in high frequency and efficiency converters such as motor controllers and industrial equipment.

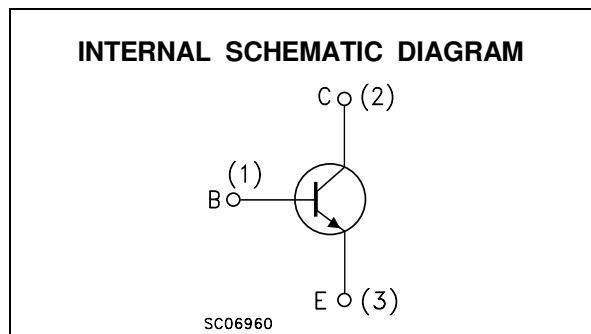
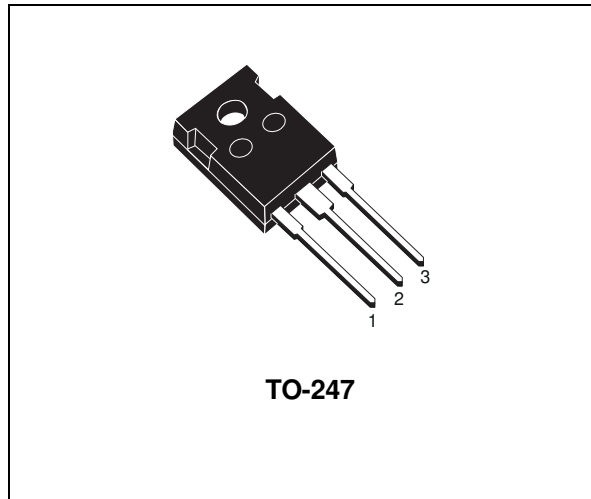

ABSOLUTE MAXIMUM RATINGS

Symbol	Parameter	Value	Unit
V_{CEV}	Collector-emitter Voltage ($V_{BE} = -1.5V$)	200	V
V_{CEO}	Collector-emitter Voltage ($I_B = 0$)	125	V
V_{EBO}	Emitter-Base Voltage ($I_C = 0$)	7	V
$I_{E(RMS)}$	Emitter Current	40	A
I_{EM}	Emitter Peak Current	120	A
I_B	Base Current	8	A
I_{BM}	Base Peak Current	24	A
P_{tot}	Total Power Dissipation at $T_{case} < 25\text{ }^\circ\text{C}$	200	W
T_{stg}	Storage Temperature	-65 to 150	$^\circ\text{C}$
T_j	Max Operating Junction Temperature	150	$^\circ\text{C}$

BUT70W

THERMAL DATA

R _{thj-case}	Thermal Resistance Junction-case	Max	0.63	°C/W
-----------------------	----------------------------------	-----	------	------

ELECTRICAL CHARACTERISTICS (T_{case} = 25 °C unless otherwise specified)

Symbol	Parameter	Test Conditions	Min.	Typ.	Max.	Unit
I _{CEr}	Collector Cut-off Current (R _{BE} = 5Ω)	V _{CE} = 200 V V _{CE} = 200 V T _C = 100°C			1 5	mA mA
I _{CEV}	Collector Cut-off Current (V _{BE} = -1.5V)	V _{CE} = 200 V V _{CE} = 200 V T _C = 100°C			1 4	mA mA
I _{EBO}	Emitter Cut-off Current (I _C = 0)	V _{EB} = 5 V			1	mA
V _{CEO(sus)*}	Collector-Emitter Sustaining Voltage (I _B = 0)	I _C = 0.2 A L = 25 mH	125			V
V _{(BR)EBO}	Emitter-Base Breakdown Voltage (I _C = 0)	I _E = 50 mA	7			V
V _{CE(sat)*}	Collector-Emitter Saturation Voltage	I _C = 70 A I _B = 7 A I _C = 70 A I _B = 7 A T _C = 100°C I _C = 35 A I _B = 1.75 A I _C = 35 A I _B = 1.75 A T _C = 100°C			0.9 1.5 0.9 1.2	V V V V
V _{BE(sat)*}	Base-Emitter Saturation Voltage	I _C = 70 A I _B = 7 A I _C = 70 A I _B = 7 A T _C = 100°C I _C = 35 A I _B = 1.75 A I _C = 35 A I _B = 1.75 A T _C = 100°C			1.8 1.9 1.4 1.4	V V V V
di _c /dt*	Rated of Rise of on-state Collector Current	V _{CC} = 100 V R _C = 0 I _{B1} = 3.5 A t _p = 3 μs T _C = 100°C	140			A/μs

* Pulsed: Pulse duration = 300 μs, duty cycle < 2 %

INDUCTIVE LOAD

Symbol	Parameter	Test Conditions	Min.	Typ.	Max.	Unit
t _s	Storage Time	I _C = 35 A V _{CC} = 90 V			1.8	μs
t _f	Fall Time	V _{BB} = -5 V R _{B2} = 1.4 Ω			0.2	μs
t _c	Cross Over Time	I _{B1} = 1.75 A L _C = 0.15 mH V _{CLAMP} = 125V T _C = 100°C			0.35	μs

Information furnished is believed to be accurate and reliable. However, STMicroelectronics assumes no responsibility for the consequences of use of such information nor for any infringement of patents or other rights of third parties which may result from its use. No license is granted by implication or otherwise under any patent or patent rights of STMicroelectronics. Specification mentioned in this publication are subject to change without notice. This publication supersedes and replaces all information previously supplied. STMicroelectronics products are not authorized for use as critical components in life support devices or systems without express written approval of STMicroelectronics.

The ST logo is a trademark of STMicroelectronics

© 2002 STMicroelectronics – Printed in Italy – All Rights Reserved

STMicroelectronics GROUP OF COMPANIES

Australia - Brazil - Canada - China - Finland - France - Germany - Hong Kong - India - Israel - Italy - Japan - Malaysia - Malta - Morocco - Singapore - Spain - Sweden - Switzerland - United Kingdom - United States.

<http://www.st.com>