



Chipsmall Limited consists of a professional team with an average of over 10 year of expertise in the distribution of electronic components. Based in Hongkong, we have already established firm and mutual-benefit business relationships with customers from,Europe,America and south Asia,supplying obsolete and hard-to-find components to meet their specific needs.

With the principle of “Quality Parts,Customers Priority,Honest Operation,and Considerate Service”,our business mainly focus on the distribution of electronic components. Line cards we deal with include Microchip,ALPS,ROHM,Xilinx,Pulse,ON,Everlight and Freescale. Main products comprise IC,Modules,Potentiometer,IC Socket,Relay,Connector.Our parts cover such applications as commercial,industrial, and automotives areas.

We are looking forward to setting up business relationship with you and hope to provide you with the best service and solution. Let us make a better world for our industry!



## Contact us

Tel: +86-755-8981 8866 Fax: +86-755-8427 6832

Email & Skype: info@chipsmall.com Web: www.chipsmall.com

Address: A1208, Overseas Decoration Building, #122 Zhenhua RD., Futian, Shenzhen, China





# BUX48/48A BUV48A/V48AFI

## HIGH POWER NPN SILICON TRANSISTORS

- STMicroelectronics PREFERRED SALESTYPES
- NPN TRANSISTOR
- HIGH VOLTAGE CAPABILITY
- HIGH CURRENT CAPABILITY
- FAST SWITCHING SPEED

### APPLICATIONS

- SWITCH MODE POWER SUPPLIES
- FLYBACK AND FORWARD SINGLE TRANSISTOR LOW POWER CONVERTERS

### DESCRIPTION

The BUX48/A, BUV48A and BUV48AFI are silicon Multiepitaxial Mesa NPN transistors mounted respectively in TO-3 metal case, TO-218 plastic package and ISOWATT218 fully isolated package. They are particularly intended for switching and industrial applications from single and three-phase mains.

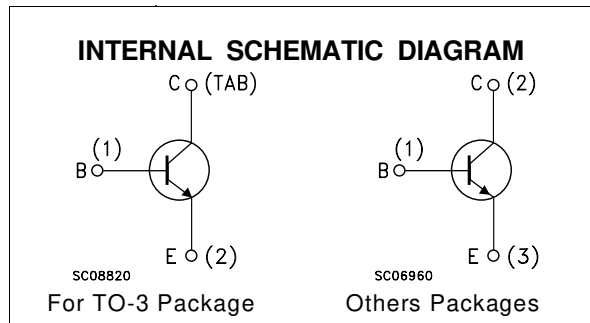
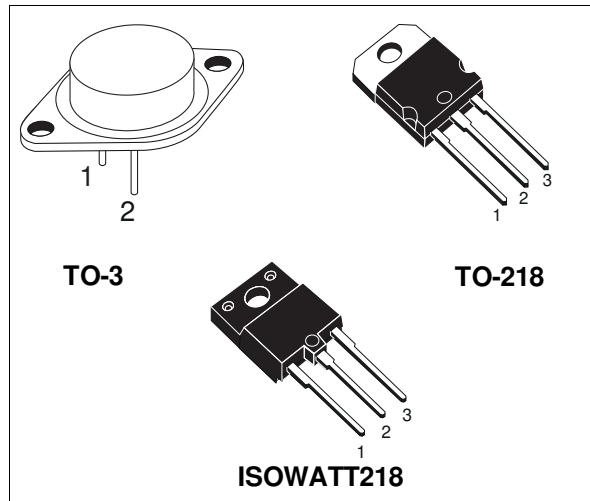

### ABSOLUTE MAXIMUM RATINGS

Symbol	Parameter	Value			Unit
		BUX48	BUX48A BUV48A BUV48AFI		
V <sub>CER</sub>	Collector-Emitter Voltage (R <sub>BE</sub> = 10Ω)	850	1000		V
V <sub>CES</sub>	Collector-Emitter Voltage (V <sub>BE</sub> = 0)	850	1000		V
V <sub>CEO</sub>	Collector-Emitter Voltage (I <sub>B</sub> = 0)	400	450		V
V <sub>EBO</sub>	Emitter-Base Voltage (I <sub>C</sub> = 0)	7			V
I <sub>C</sub>	Collector Current	15			A
I <sub>CM</sub>	Collector Peak Current	30			A
I <sub>CP</sub>	Collector Peak Current non repetitive (t <sub>p</sub> < 20μs)	55			A
I <sub>B</sub>	Base Current	4			A
I <sub>BM</sub>	Base Peak Current	20			A
		<b>TO-3</b>	<b>TO-218</b>	<b>ISOWATT218</b>	
P <sub>tot</sub>	Total Dissipation at T <sub>c</sub> = 25 °C	175	125	55	W
T <sub>stg</sub>	Storage Temperature	-65 to 200	-65 to 150	-65 to 150	°C
T <sub>j</sub>	Max. Operating Junction Temperature	200	150	150	°C

## BUX48 / BUX48A / BUV48A / BUV48AFI

### THERMAL DATA

		TO-3	TO-218	ISOWATT218	
R <sub>thj-case</sub>	Thermal Resistance Junction-case Max	1	1	2.2	°C/W

### ELECTRICAL CHARACTERISTICS (T<sub>case</sub> = 25 °C unless otherwise specified)

Symbol	Parameter	Test Conditions	Min.	Typ.	Max.	Unit
I <sub>CES</sub>	Collector Cut-off Current (V <sub>BE</sub> = 0)	V <sub>CE</sub> = rated V <sub>CES</sub> V <sub>CE</sub> = rated V <sub>CES</sub> , T <sub>c</sub> = 125 °C			200 2	μA mA
I <sub>CER</sub>	Collector Cut-off Current (R <sub>BE</sub> = 10 Ω)	V <sub>CE</sub> = rated V <sub>CER</sub> V <sub>CE</sub> = rated V <sub>CER</sub> , T <sub>c</sub> = 125 °C			500 4	μA mA
I <sub>EBO</sub>	Emitter Cut-off Current (I <sub>C</sub> = 0)	V <sub>EB</sub> = 5 V			1	mA
V <sub>CEO(SUS)</sub> *	Collector-Emitter Sustaining Voltage (I <sub>B</sub> = 0)	I <sub>C</sub> = 200 mA L = 25mH for <b>BUX48</b> for <b>BUX48A/V48A/V48AFI</b>	400 450			V V
V <sub>EBO</sub>	Emitter-Base Voltage (I <sub>C</sub> = 0)	I <sub>E</sub> = 50 mA	7		30	V
V <sub>CE(sat)</sub> *	Collector-Emitter Saturation Voltage	for <b>BUX48</b> I <sub>C</sub> = 10 A I <sub>B</sub> = 2 A I <sub>C</sub> = 15 A I <sub>B</sub> = 4 A I <sub>C</sub> = 15 A I <sub>B</sub> = 3 A for <b>BUX48A/V48A/V48AFI</b> I <sub>C</sub> = 8 A I <sub>B</sub> = 1.6 A I <sub>C</sub> = 12 A I <sub>B</sub> = 2.4 A			1.5 3.5 5 1.5 5	V V V V V
V <sub>BE(sat)</sub> *	Base-Emitter Saturation Voltage	for <b>BUX48</b> I <sub>C</sub> = 10 A I <sub>B</sub> = 2 A for <b>BUX48A/V48A/V48AFI</b> I <sub>C</sub> = 8 A I <sub>B</sub> = 1.6 A			1.6 1.6	V V

\* Pulsed: Pulse duration = 300 μs, duty cycle ≤ 2 %

### RESISTIVE SWITCHING TIMES

Symbol	Parameter	Test Conditions	Min.	Typ.	Max.	Unit
t <sub>on</sub>	Turn-on Time	for <b>BUX48</b> V <sub>CC</sub> = 150 V I <sub>C</sub> = 10 A I <sub>B1</sub> = 2 A for <b>BUX48A/V48A/V48AFI</b> V <sub>CC</sub> = 150 V I <sub>C</sub> = 8 A I <sub>B1</sub> = 1.6 A			1 1	μs μs
t <sub>s</sub>	Storage Time	for <b>BUX48</b> V <sub>CC</sub> = 150 V I <sub>C</sub> = 10 A I <sub>B1</sub> = - I <sub>B2</sub> = 2 A for <b>BUX48A/V48A/V48AFI</b> V <sub>CC</sub> = 150 V I <sub>C</sub> = 8 A I <sub>B1</sub> = - I <sub>B2</sub> = 1.6 A			3 3	μs μs
t <sub>f</sub>	Fall Time	for <b>BUX48</b> V <sub>CC</sub> = 150 V I <sub>C</sub> = 10 A I <sub>B1</sub> = - I <sub>B2</sub> = 2 A for <b>BUX48A/V48A/V48AFI</b> V <sub>CC</sub> = 150 V I <sub>C</sub> = 8 A I <sub>B1</sub> = - I <sub>B2</sub> = 1.6 A			0.8 0.8	μs μs

INDUCTIVE SWITCHING TIMES

Symbol	Parameter	Test Conditions	Min.	Typ.	Max.	Unit
t <sub>s</sub>	Storage Time	for <b>BUX48</b> V <sub>CC</sub> = 300 V      I <sub>C</sub> = 10 A L <sub>B</sub> = 3 μH V <sub>BE</sub> = -5 V      I <sub>B1</sub> = 2 A same conditions at T <sub>c</sub> = 125 °C		2.7	5	μs μs
		for <b>BUX48A/V48A/V48AFI</b> V <sub>CC</sub> = 300 V      I <sub>C</sub> = 8 A L <sub>B</sub> = 3 μH V <sub>BE</sub> = -5 V      I <sub>B1</sub> = 1.6 A same conditions at T <sub>c</sub> = 125 °C		3	5	μs μs
t <sub>f</sub>	Fall Time	for <b>BUX48</b> V <sub>CC</sub> = 300 V      I <sub>C</sub> = 10 A L <sub>B</sub> = 3 μH V <sub>BE</sub> = -5 V      I <sub>B1</sub> = 2 A same conditions at T <sub>c</sub> = 125 °C		0.16	0.4	μs μs
		for <b>BUX48A/V48A/V48AFI</b> V <sub>CC</sub> = 300 V      I <sub>C</sub> = 8 A L <sub>B</sub> = 3 μH V <sub>BE</sub> = -5 V      I <sub>B1</sub> = 1.6 A same conditions at T <sub>c</sub> = 125 °C		0.13	0.4	μs μs

**TO-3 MECHANICAL DATA**

DIM.	mm			inch		
	MIN.	TYP.	MAX.	MIN.	TYP.	MAX.
A	11.00		13.10	0.433		0.516
B	0.97		1.15	0.038		0.045
C	1.50		1.65	0.059		0.065
D	8.32		8.92	0.327		0.351
E	19.00		20.00	0.748		0.787
G	10.70		11.10	0.421		0.437
N	16.50		17.20	0.649		0.677
P	25.00		26.00	0.984		1.023
R	4.00		4.09	0.157		0.161
U	38.50		39.30	1.515		1.547
V	30.00		30.30	1.187		1.193

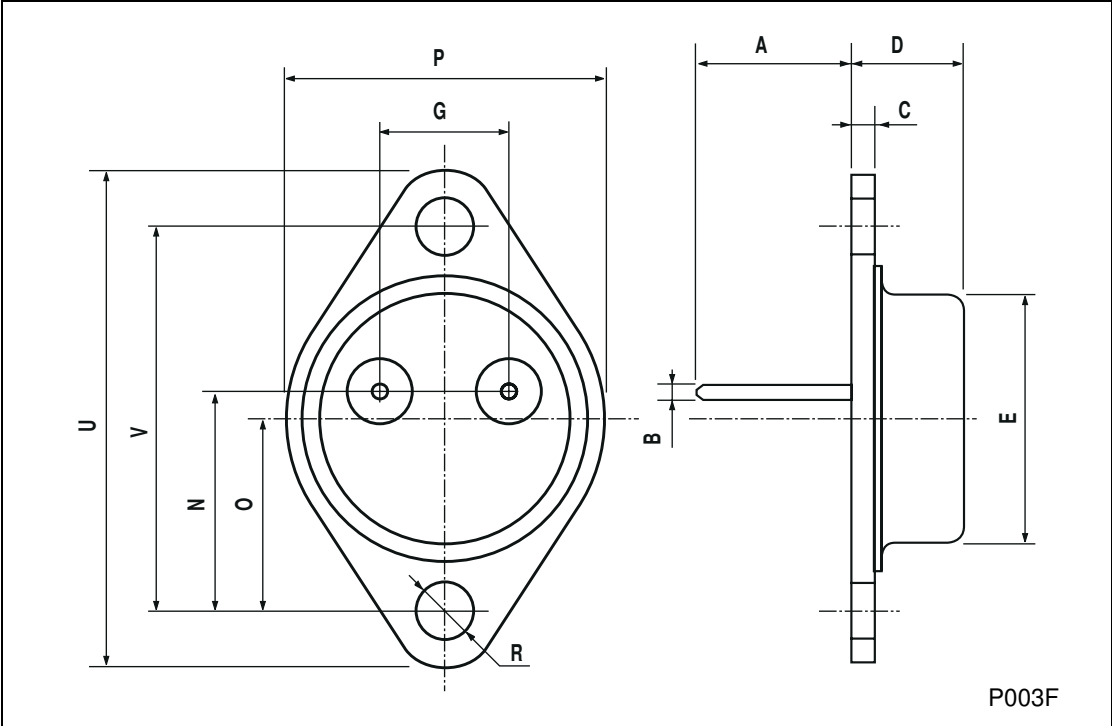

**TO-218 (SOT-93) MECHANICAL DATA**

DIM.	mm			inch		
	MIN.	TYP.	MAX.	MIN.	TYP.	MAX.
A	4.7		4.9	0.185		0.193
C	1.17		1.37	0.046		0.054
D		2.5			0.098	
E	0.5		0.78	0.019		0.030
F	1.1		1.3	0.043		0.051
G	10.8		11.1	0.425		0.437
H	14.7		15.2	0.578		0.598
L2	-		16.2	-		0.637
L3		18			0.708	
L5	3.95		4.15	0.155		0.163
L6		31			1.220	
R	-		12.2	-		0.480
Ø	4		4.1	0.157		0.161

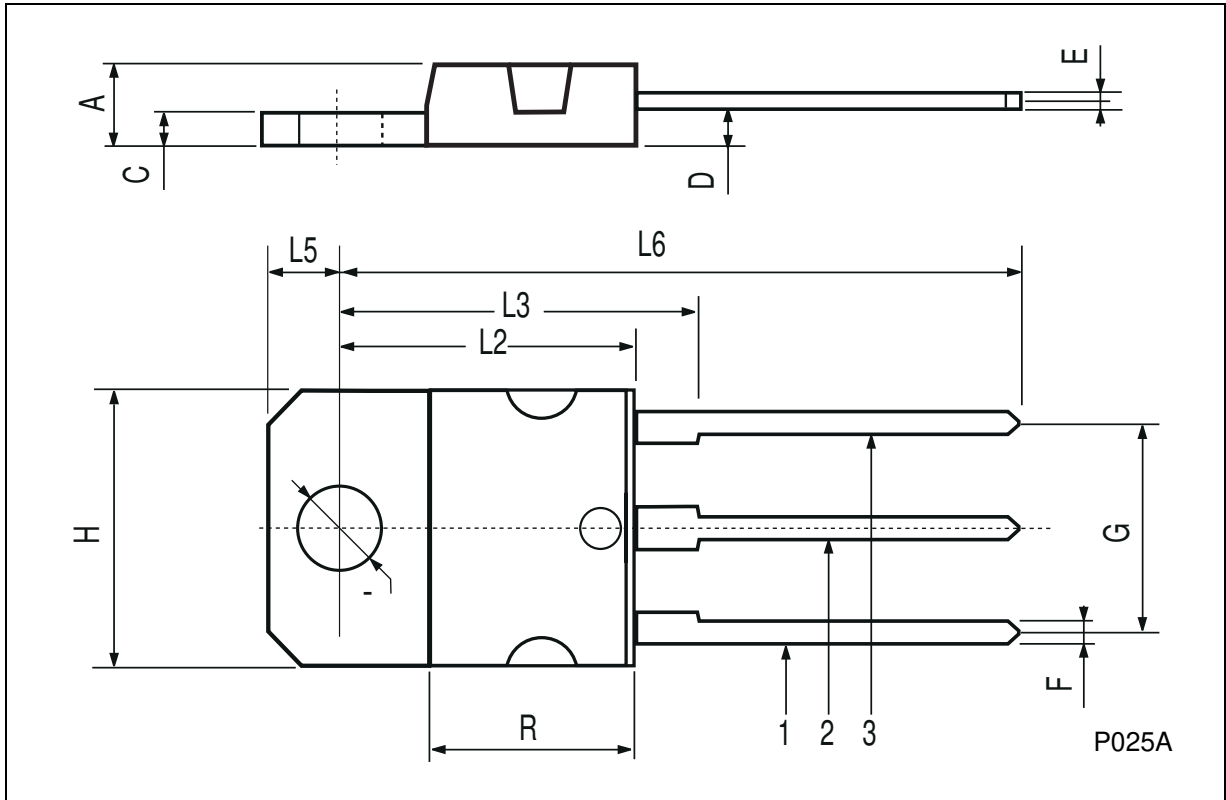

**ISOWATT218 MECHANICAL DATA**

DIM.	mm			inch		
	MIN.	TYP.	MAX.	MIN.	TYP.	MAX.
A	5.35		5.65	0.211		0.222
C	3.30		3.80	0.130		0.150
D	2.90		3.10	0.114		0.122
D1	1.88		2.08	0.074		0.082
E	0.75		0.95	0.030		0.037
F	1.05		1.25	0.041		0.049
F2	1.50		1.70	0.059		0.067
F3	1.90		2.10	0.075		0.083
G	10.80		11.20	0.425		0.441
H	15.80		16.20	0.622		0.638
L		9			0.354	
L1	20.80		21.20	0.819		0.835
L2	19.10		19.90	0.752		0.783
L3	22.80		23.60	0.898		0.929
L4	40.50		42.50	1.594		1.673
L5	4.85		5.25	0.191		0.207
L6	20.25		20.75	0.797		0.817
N	2.1		2.3	0.083		0.091
R		4.6			0.181	
DIA	3.5		3.7	0.138		0.146

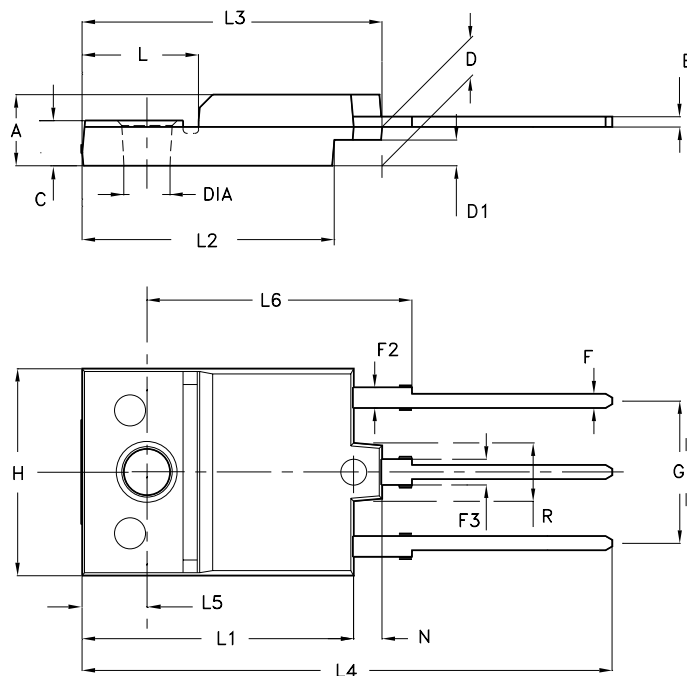

- Weight : 4.9 g (typ.)
- Maximum Torque (applied to mounting flange) Recommended: 0.8 Nm; Maximum: 1 Nm
- The side of the dissipator must be flat within 80 μm

P025C/A



Information furnished is believed to be accurate and reliable. However, STMicroelectronics assumes no responsibility for the consequences of use of such information nor for any infringement of patents or other rights of third parties which may result from its use. No license is granted by implication or otherwise under any patent or patent rights of STMicroelectronics. Specification mentioned in this publication are subject to change without notice. This publication supersedes and replaces all information previously supplied. STMicroelectronics products are not authorized for use as critical components in life support devices or systems without express written approval of STMicroelectronics.

The ST logo is a trademark of STMicroelectronics

© 2000 STMicroelectronics – Printed in Italy – All Rights Reserved

STMicroelectronics GROUP OF COMPANIES

Australia - Brazil - China - Finland - France - Germany - Hong Kong - India - Italy - Japan - Malaysia - Malta - Morocco -  
Singapore - Spain - Sweden - Switzerland - United Kingdom - U.S.A.

<http://www.st.com>