



Chipsmall Limited consists of a professional team with an average of over 10 year of expertise in the distribution of electronic components. Based in Hongkong, we have already established firm and mutual-benefit business relationships with customers from,Europe,America and south Asia,supplying obsolete and hard-to-find components to meet their specific needs.

With the principle of “Quality Parts,Customers Priority,Honest Operation,and Considerate Service”,our business mainly focus on the distribution of electronic components. Line cards we deal with include Microchip,ALPS,ROHM,Xilinx,Pulse,ON,Everlight and Freescale. Main products comprise IC,Modules,Potentiometer,IC Socket,Relay,Connector.Our parts cover such applications as commercial,industrial, and automotives areas.

We are looking forward to setting up business relationship with you and hope to provide you with the best service and solution. Let us make a better world for our industry!



Contact us

Tel: +86-755-8981 8866 Fax: +86-755-8427 6832

Email & Skype: info@chipsmall.com Web: www.chipsmall.com

Address: A1208, Overseas Decoration Building, #122 Zhenhua RD., Futian, Shenzhen, China





AirPrime BX310x Wi-Fi/BT Module

Product Technical Specification

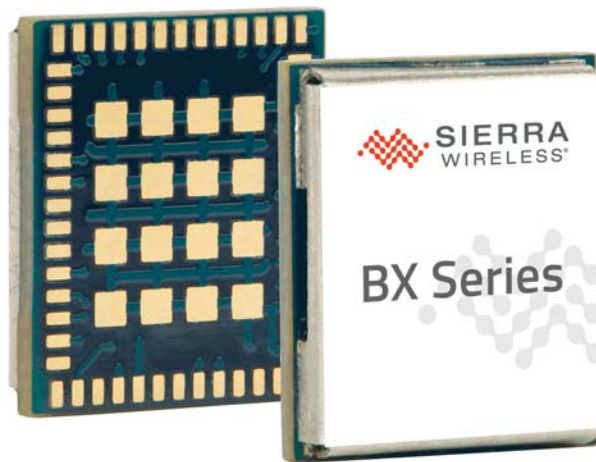

SIERRA
WIRELESS®

41111444
Rev 2

Important Notice

Due to the nature of wireless communications, transmission and reception of data can never be guaranteed. Data may be delayed, corrupted (i.e., have errors) or be totally lost. Although significant delays or losses of data are rare when wireless devices such as the Sierra Wireless modem are used in a normal manner with a well-constructed network, the Sierra Wireless modem should not be used in situations where failure to transmit or receive data could result in damage of any kind to the user or any other party, including but not limited to personal injury, death, or loss of property. Sierra Wireless accepts no responsibility for damages of any kind resulting from delays or errors in data transmitted or received using the Sierra Wireless modem, or for failure of the Sierra Wireless modem to transmit or receive such data.

Safety and Hazards

Do not operate the Sierra Wireless modem in areas where blasting is in progress, where explosive atmospheres may be present, near medical equipment, near life support equipment, or any equipment which may be susceptible to any form of radio interference. In such areas, the Sierra Wireless modem **MUST BE IN AIRPLANE MODE OR POWERED OFF**. The Sierra Wireless modem can transmit signals that could interfere with this equipment.

Do not operate the Sierra Wireless modem in any aircraft, whether the aircraft is on the ground or in flight. In aircraft, the Sierra Wireless modem **MUST BE IN AIRPLANE MODE OR POWERED OFF**. When operating, the Sierra Wireless modem can transmit signals that could interfere with various onboard systems.

Note: Some airlines may permit the use of cellular phones while the aircraft is on the ground and the door is open. Sierra Wireless modems may be used at this time.

The driver or operator of any vehicle should not operate the Sierra Wireless modem while in control of a vehicle. Doing so will detract from the driver or operator's control and operation of that vehicle. In some states and provinces, operating such communications devices while in control of a vehicle is an offence.

Limitation of Liability

The information in this manual is subject to change without notice and does not represent a commitment on the part of Sierra Wireless. SIERRA WIRELESS AND ITS AFFILIATES SPECIFICALLY DISCLAIM LIABILITY FOR ANY AND ALL DIRECT, INDIRECT, SPECIAL, GENERAL, INCIDENTAL, CONSEQUENTIAL, PUNITIVE OR EXEMPLARY DAMAGES INCLUDING, BUT NOT LIMITED TO, LOSS OF PROFITS OR REVENUE OR ANTICIPATED PROFITS OR REVENUE ARISING OUT OF THE USE OR INABILITY TO USE ANY SIERRA WIRELESS PRODUCT, EVEN IF SIERRA WIRELESS AND/OR ITS AFFILIATES HAS BEEN ADVISED OF THE POSSIBILITY OF SUCH DAMAGES OR THEY ARE FORESEEABLE OR FOR CLAIMS BY ANY THIRD PARTY.

Notwithstanding the foregoing, in no event shall Sierra Wireless and/or its affiliates aggregate liability arising under or in connection with the Sierra Wireless product, regardless of the number of events, occurrences, or claims giving rise to liability, be in excess of the price paid by the purchaser for the Sierra Wireless product.

Patents

This product may contain technology developed by or for Sierra Wireless Inc. This product is manufactured or sold by Sierra Wireless Inc. or its affiliates under one or more patents licensed from MMP Portfolio Licensing.

Copyright

©2017 Sierra Wireless. All rights reserved.

Trademarks

Sierra Wireless®, AirPrime®, AirLink®, AirVantage® and the Sierra Wireless logo are registered trademarks of Sierra Wireless, Inc.

Windows® and Windows Vista® are registered trademarks of Microsoft Corporation.

Other trademarks are the property of their respective owners.

Contact Information

Sales information and technical support, including warranty and returns	Web: sierrawireless.com/company/contact-us/ Global toll-free number: 1-877-687-7795 6:00 am to 5:00 pm PST
Corporate and product information	Web: sierrawireless.com

Revision History

Revision number	Release date	Changes
1	August 2017	Creation (limited release)
2	October 2017	General release

>> Contents

1: Introduction	8
1.1 Module Variants	8
1.2 General RF/Software Features	8
1.2.1 Wi-Fi	8
1.2.2 Bluetooth	8
1.2.3 Interfaces	9
1.2.4 Configuration Utility	9
1.3 General Hardware Features	9
1.3.1 Physical Dimensions and Connection Interface	9
2: Functional Specifications	11
2.1 Architecture	11
2.2 Features	12
3: Technical Specifications	15
3.1 Environmental	15
3.2 Power Supply Ratings	15
3.2.1 Power Management	16
3.2.2 Current Consumption	16
3.3 RF	18
3.3.1 Generic Radio	18
3.3.2 Wi-Fi Radio	18
3.3.3 Bluetooth Radio	19
3.4 Electrical Specifications	20
3.4.1 Absolute Maximum Ratings	20
3.5 Mechanical	20
3.6 Mechanical Drawings	20
3.7 Antenna	22
4: Interfaces Specification	23
4.1 Overview	23
4.2 UART	23

4.3 ADC	24
4.4 Voltage Measurement	24
4.5 I2C Interface	24
4.5.1 Application	25
4.6 I2S Interface (Digital Audio)	26
4.7 General Purpose Input/Output (GPIO)	26
4.8 SPI Bus	27
4.9 Secure Digital IO (SDIO) Interface	28
4.10 Module Enable	28
4.11 Clock	29
4.12 PWM	29
5: Regulatory Certifications	30
United States	30
Canada	31
Bluetooth Qualification Program (BQP)	31
6: Pinout	32
6.1 Pin Configuration	33
6.2 Pin Description	33
7: Abbreviations	37

>> | List of Figures

Figure 2-1: AirPrime BX310x Application Schematic	11
Figure 2-2: Block diagram	12
Figure 3-1: AirPrime BX3100 Mechanical Drawing	21
Figure 3-2: AirPrime BX3105 Mechanical Drawing	22
Figure 4-1: Example of I2C Bus Application	25
Figure 6-1: Pin Configuration (Bottom View)	33

>> | List of Tables

Table 1-1: Supported RF Frequencies.	8
Table 1-2: AirPrime BX310x Dimensions.	9
Table 1-3: LGA Pad Types	10
Table 2-1: AirPrime BX310x Capabilities.	12
Table 3-1: Environmental Specifications	15
Table 3-2: Power Supply Pins	15
Table 3-3: Power Modes—Descriptions	16
Table 3-4: Power Modes—Typical Current Consumption.	16
Table 3-5: RF Current Consumption Specifications.	17
Table 3-6: Generic Radio Characteristics	18
Table 3-7: Generic Radio Characteristics	18
Table 3-8: Generic Radio Characteristics	19
Table 3-9: Absolute Maximum Ratings	20
Table 3-10: Recommended Operating Conditions.	20
Table 4-1: UART0 Pins	23
Table 4-2: ADC Interface Pins	24
Table 4-3: Voltage-measurement GPIO Pins	24
Table 4-4: I2C Interface Pins	25
Table 4-5: I2S Interface Pins	26
Table 4-6: GPIO Pins (Dedicated)	26
Table 4-8: SPI Pin Descriptions.	27
Table 4-7: GPIO Pins (Alternate function)	27
Table 4-9: SDIO Pin Descriptions	28
Table 4-10: Enable Pin Description	28
Table 6-1: Pin Definitions.	33
Table 7-1: Acronyms and Definitions.	37

>> 1: Introduction

This document defines and illustrates the AirPrime BX310x (BX3100, BX3105) Wi-Fi/BT Host-less module's high-level product features, interfaces, and hardware features (including electrical and mechanical performance criteria).

1.1 Module Variants

AirPrime BX310x module variants include:

- AirPrime BX3100—External antenna connection
- AirPrime BX3105—Embedded antenna

1.2 General RF/Software Features

The AirPrime BX310x is a low-power, small form-factor self-contained Wi-Fi/Bluetooth (Wi-Fi/BT) module.

With an embedded software suite, the BX310x is an ideal solution for developers who want to quickly and cost-effectively integrate Wi-Fi/BT functionality into their products.

The following table summarizes the module's supported wireless frequencies:

Table 1-1: Supported RF Frequencies

Technology	RF band	Notes
Wi-Fi	• 2.4GHz (2.400–2.485 GHz)	• 802.11b/g/n/e/i
		• Max data rate—MCS7 HT40 150 Mbps
Bluetooth		• v4.2 BR/EDR and BLE compliant

1.2.1 Wi-Fi

The AirPrime BX310x supports 2.4 GHz Wi-Fi operation. Key features include:

- TCP/IP
- 802.11 b/g/n/e/i
- Connection methods—BSS STA, SoftAP, Wi-Fi Direct (Wi-Fi P2P)
- Transmit power—Adjustable, up to 21 dBm (maximum)

For a list of additional supported Wi-Fi functionality, protocols, and features, see [Features on page 12](#).

1.2.2 Bluetooth

The AirPrime BX310x supports 2.4 GHz Bluetooth classic and BLE operation. Key features include:

- Bluetooth v4.2 BR/EDR and BLE compliant
- SPP (Serial Port Profile)

For a list of additional supported Bluetooth functionality, protocols, and features, see [Features on page 12](#).

1.2.3 Interfaces

The AirPrime BX310x provides the following interfaces and peripheral connectivity:

- Power supply—See [Power Supply Ratings on page 15](#).
- RF—See [RF on page 18](#).
- UART serial link—See [UART on page 23](#).
- ADC—See [ADC on page 24](#).
- Voltage measurement—See [Voltage Measurement on page 24](#).
- I²C—See [I2C Interface on page 24](#).
- Digital audio (I²S)—See [I2S Interface \(Digital Audio\) on page 26](#).
- GPIOs—See [General Purpose Input/Output \(GPIO\) on page 26](#).
- SPI bus—See [SPI Bus on page 27](#).
- SDIO—See [Secure Digital IO \(SDIO\) Interface on page 28](#).
- Module enable—See [Module Enable on page 28](#).
- System clock outputs—See [Clock on page 29](#).
- PWM—See [PWM on page 29](#).

1.2.4 Configuration Utility

The AirPrime BX310x includes a browser-based utility for device configuration. For usage details, refer to the AirPrime BX Series Development Kit User Guide available at source.sierrawireless.com (forthcoming).

1.3 General Hardware Features

1.3.1 Physical Dimensions and Connection Interface

AirPrime BX310x modules are compact, robust, fully shielded and labeled modules with the dimensions noted in [Table 1-2](#).

Table 1-2: AirPrime BX310x Dimensions^a

Parameter	Nominal		Tolerance	Units
	BX3100 ^b	BX3105		
Length	11.5	13.5	±0.10	mm
Width	9.5	11.5	±0.10	mm
Thickness	2.4	2.4	±0.20	mm
Weight	TBD	TBD	TBD	g

a. Dimensions are accurate as of the release date of this document.

b. BX3100 is a CF3 xSmall module, which belongs to the Common Flexible Form Factor (CF3) family of WWAN modules

The AirPrime BX310x module is an LGA form factor device. All electrical and mechanical connections are made through the 70 Land Grid Array (LGA) pads on the bottom side of the PCB. (See [Figure 6-1 on page 33](#) for details.)

The LGA pads have the following distribution:

Table 1-3: LGA Pad Types

Pad Type/Quantity		Dimensions	Pitch
Signal Pads	54 outer pads	0.75x0.35 mm	0.65 mm
Ground Pads	16 inner pads	1.0x1.0 mm	1.83 mm/1.48 mm



2: Functional Specifications

2.1 Architecture

The following figure presents an overview of the AirPrime BX310x module's internal architecture and external interfaces.

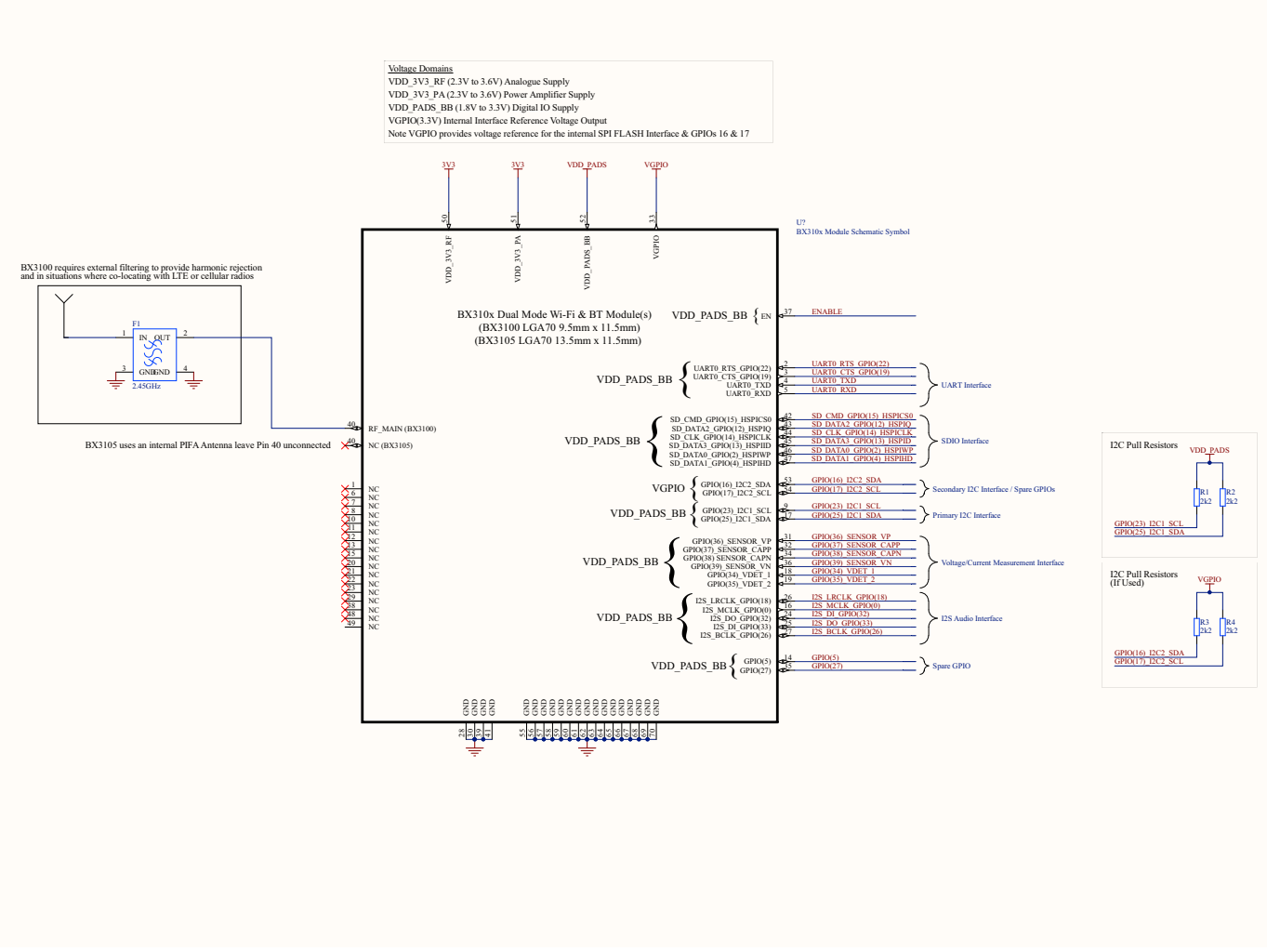

Figure 2-1: AirPrime BX310x Application Schematic

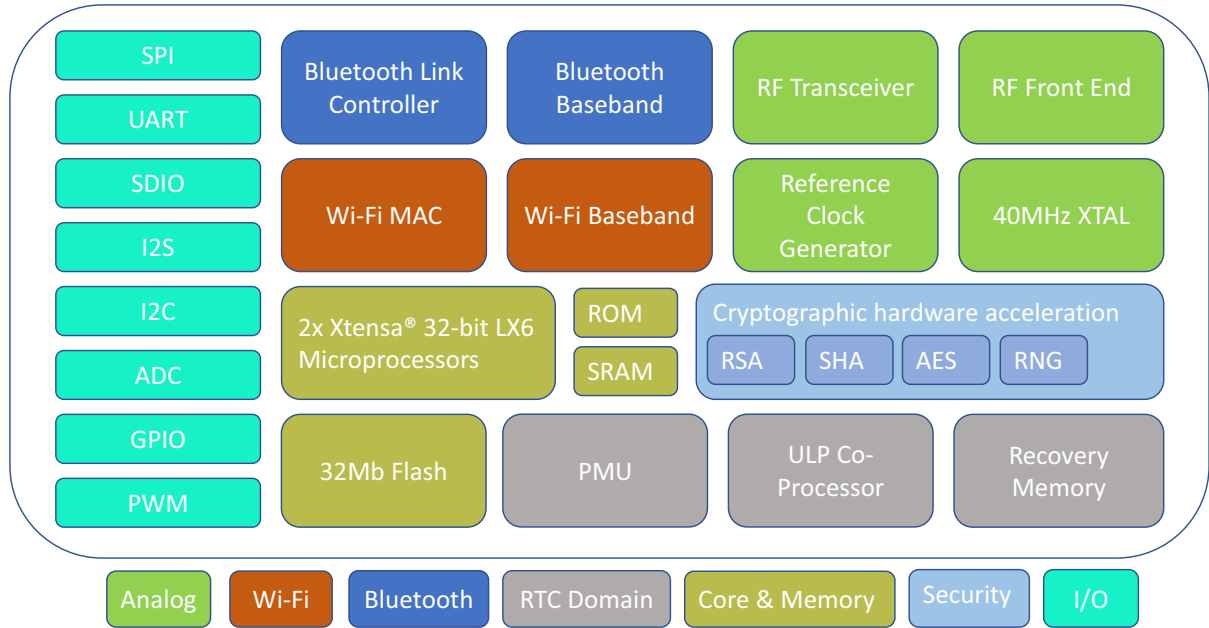

Figure 2-2: Block diagram

2.2 Features

Table 2-1 summarizes the AirPrime BX310x module’s RF (Wi-Fi and Bluetooth), Power, software, and hardware capabilities.

Note: Table contents are preliminary and subject to change.

Table 2-1: AirPrime BX310x Capabilities

Feature	Description
Module	<ul style="list-style-type: none"> Secure boot Secure update FOTA (Firmware update Over The Air) Sierra Wireless AirVantage support CF3-compliant footprint (BX3100)

Table 2-1: AirPrime BX310x Capabilities (Continued)

Feature	Description
Wi-Fi	<ul style="list-style-type: none"> • Protocols: <ul style="list-style-type: none"> • 802.11 b/g/n/e/i • 802.11 n (2.4 GHz), up to 150 Mbps; MCS0-7 in 20/40 MHz bandwidths • Receiving STBC (Space-time Block Code) 2x1 • 802.11 e: QoS for wireless multimedia technology • Additional 802.11i security features (pre-authentication, TSN, etc.) • WMM-PS, UAPSD • A-MPDU, A-MSDU aggregation • Block ACK (RTS/CTS/ACK/BA) • Fragmentation/defragmentation • CCMP (CBC-MAC, counter model), TKIP (MIC, RC4), WAPI (SMS4), WEP (RC4), CRC • Frame encapsulation (802.11h/RFC 1042) • Pre-authentication, TSN • Supported channels—1–14 • Autoconnection—After device reset, automatically connects to available AP based on previous configuration • Infrastructure BSS Station mode/SoftAP mode: AP mode, STA mode, concurrent AP/STA mode • Up to 8 simultaneous Wi-Fi clients • IP configuration—IP address in STA mode via DHCP or static assignment • Authentication (security) modes: WPA, WPA2, WPA/WPA2, WPA2 Enterprise • UMA-compliant and certified • Open interface for various upper layer authentication schemes over EAP (e.g. TLS, PEAP, LEAP, SIM, AKA, customer-specific) • Adaptive rate fallback algorithm • Automatic retransmission/response on slow hosts

Table 2-1: AirPrime BX310x Capabilities (Continued)

Feature	Description
Bluetooth	<ul style="list-style-type: none"> • Bluetooth v4.2 BR/EDR and BLE compliant • Supported channels: BT Classic—0–78; BLE—0–39 • Supported v4.2 modes: BR (Basic Rate); EDR (Enhanced Data Rate); LE (Low Energy) • BT classic mandatory features • BT low-energy mandatory features • Class 1/Class 2/Class 3 transmitter without external power amplifier • Class 1 operation without external PA • Enhanced power control (>30 dB dynamic control range) • +10 dBm transmitting power • NZIF receiver with -98 dBm sensitivity • Modulation—p/4 DQPSK, 8 DPSK • ACL, SCO, eSCO, AFH • Adaptive Frequency Hopping (AFH) • BT 4.2 controller and host stack • Service Discover Protocol (SDP) • General Access Profile (GAP) • Security Manage Protocol (SMP) • Bluetooth Low Energy (BLE) • ATT/GATT • BLE Beacon • SPP, RFCOMM • Profiles: SPPAutoconnection—After device reset, automatically connects to available AP based on previous configuration. • UART features: GATT profiles, Data transfer (HTTP, HTTPS, MQTT, TCP/UDP), Define personal services • Roles—Simultaneous Central (access point)/Peripheral (client) • Simultaneous connections: <ul style="list-style-type: none"> • Up to 7 (total) simultaneous connections, including up to 3 BLE connections • Simultaneous BT Classic and BLE connections • PCM/I2S
Configuration	Device configuration methods: <ul style="list-style-type: none"> • Built-in web-based configuration utility. See Configuration Utility on page 9. • AT commands available over UART, Wi-Fi, and BT links. Refer to AirPrime BX310x AT Command Reference at source.sierrawireless.com.
Security	<ul style="list-style-type: none"> • All standard IEEE802.11 security features, including WFA, WPA/WPA2, WAPI • Secure boot • Flash encryption • Cryptographic hardware acceleration: AES, HASH (SHA-2) library, RSA, ECC, Random Number Generator (RNG)
Power management	Multiple power modes to reduce power consumption: Active, Radio off, Light sleep, Deep sleep, Hibernation Sleep Patterns: Association sleep pattern, ULP sensor-monitored pattern

3: Technical Specifications

3.1 Environmental

The environmental specifications for operation and storage of the AirPrime BX310x are defined in Table 3-1.

Table 3-1: Environmental Specifications

Parameter	Range
Ambient Operating Temperature	-40°C to +85°C
Ambient Storage Temperature	-40°C to +105°C (Recommended)
Ambient Humidity	TBD

3.2 Power Supply Ratings

DC power is supplied via the pins described in [Table 3-2 on page 15](#).

Note: Operation above the maximum specified operating voltage (see [Table 3-10 on page 20](#)) is not recommended, and specified typical performance or functional operation of the device is neither implied nor guaranteed.

Table 3-2: Power Supply Pins

Pin	Name	Voltage	Direction	Function
33	VGPI0	3.3V	Output	Supply voltage reference for secondary I2C interface (pins 53/54)
50	VDD_3V3_RF	2.7–3.6V	Input	RF/Analog signal power supply
51	VDD_3V3_PA	2.7–3.6V	Input	Internal Power Amplifier power supply
52	VDD_3V3_BB	1.8–3.3V	Input	Baseband/Digital I/O power supply

3.2.1 Power Management

The AirPrime BX310x switches between several power modes to minimize current consumption. The following tables describe these modes and their typical current consumption:

Table 3-3: Power Modes—Descriptions

Power Mode	CPU	Wi-Fi / BT radio / baseband	RTC	ULP co-processor	Notes
Active	On	On	On	On	Fully functional
Radio off	On	Off	On	On	
Light sleep	Pause	Off	On	On	Wake up events will wake the module.
Deep sleep	Off	Off	On	On/Off	Connection data stored in RTC memory
Hibernate	Off	Off	Off	Off	Only RTC timer or specific RTC GPIOs can wake the module.

Table 3-4: Power Modes—Typical Current Consumption

Power Mode	Description	Current Consumption
Active (RF on)	Wi-Fi Tx packet 13 dB~21 dBm	160~260 mA
	Wi-Fi/BT Tx packet 0 dBm	120 mA
	Wi-Fi/BT Rx and listening	80~90 mA
	Association sleep patter (by Light-sleep)	0.9 mA@DTIM3, 1.2 mA@DTIM1
Modem-sleep	CPU is powered on.	Max speed: 20 mA
		Normal speed: 5~10 mA
		Slow speed: 3 mA
Light-sleep	-	0.8 mA
Deep-sleep	ULP processor powered on	0.15 mA
	ULP sensor-monitored pattern	25 μ A @ 1% duty
	RTC timer + RTC memory	10 μ A
Hibernation	RTC timer only	5 μ A

3.2.2 Current Consumption

Current consumption measurements are conducted at the module antenna port with 3.0 V supply at 25°C ambient temperature.

All transmitter measurements are based on 90% duty cycle and continuous transmit mode.

Table 3-5: RF Current Consumption Specifications

Mode	Min	Typ	Max	Unit
Transmit 802.11b, DSSS 1 Mbps, POUT=+18.0 dBm	-	225	-	mA
Transmit 802.11b, CCK 11 Mbps, POUT=+18.0 dBm	-	205	-	mA
Transmit 802.11g, OFDM 54 Mbps, POUT = +14 dBm	-	160	-	mA
Transmit 802.11n, MCS7 HT20, POUT=+11.5 dBm	-	152	-	mA
Transmit 802.11n, MCS7 HT40, POUT=+11.5 dBm	-	152	-	mA
Receive 802.11b, packet length=1024 bytes, -80 dBm	-	85	-	mA
Receive 802.11g, packet length=1024 bytes, -70 dBm	-	85	-	mA
Receive 802.11n HT20, packet length=1024 bytes, -65 dBm	-	80	-	mA
Receive 802.11n HT40, packet length=1024 bytes, -65 dBm	-	80	-	mA
Power Save, DTIM 1		TBD		mA
Power Save, DTIM 3		TBD		mA
Power Save, DTIM 10		TBD		mA
Continuous Transmit Bluetooth 1 Mbps		TBD		mA
Continuous Transmit Bluetooth 2 Mbps		TBD		mA
Continuous Transmit Bluetooth 3 Mbps		TBD		mA
Continuous Bluetooth Receive		TBD		mA
1.28 sec page scan (non-interlaced)		TBD		mA
1.28 sec LE ADV		TBD		mA
1.28 sec Sniff as master		TBD		mA
1.28 sec Sniff as slave		TBD		mA
Modem Sleep		10		mA
Light Sleep		0.8		mA
Deep Sleep		25		μA
Hibernation		5		μA

3.3 RF

3.3.1 Generic Radio

Measurements conducted at 25°C ambient temperature.

Table 3-6: Generic Radio Characteristics

Description	Min	Typ	Max	Unit
BX3100 RF Port Impedance		50		Ω
Frequency Band	2.4	2.45	2.485	GHz
BX3105 Antenna Gain		TBD		dBi

3.3.2 Wi-Fi Radio

Measurements conducted at 25°C ambient temperature.

Table 3-7: Generic Radio Characteristics

Description	Min	Typ	Max	Unit
Transmit 802.11b, CCK 11 Mbps, Output Power, EVM and Mask Compliant		18.0		dBm
Transmit 802.11g, OFDM 54 Mbps, Output Power, EVM and Mask Compliant		14.0		dBm
Transmit 802.11n, MCS7 HT20 72.2 Mbps, Output Power, EVM and Mask Compliant		11.5		dBm
Transmit 802.11n, MCS7 HT40 135 Mbps, Output Power, EVM and Mask Compliant		11.5		dBm
Receiver Sensitivity 11b DSSS, 1 Mbps		TBD		dBm
Receiver Sensitivity 11b CCK, 11 Mbps		TBD		dBm
Receiver Sensitivity 11g OFDM, 6 Mbps		TBD		dBm
Receiver Sensitivity 11g OFDM, 54 Mbps		TBD		dBm
Receiver Sensitivity 11n HT20 OFDM, 72.2 Mbps		TBD		dBm
Receiver Sensitivity 11n HT40 OFDM, 135 Mbps		TBD		dBm
BX3100 Harmonics 2F0		-35		dBm
BX3100 Harmonics 3F0		-50		dBm

3.3.3 Bluetooth Radio

Measurements conducted at 25°C ambient temperature.

Table 3-8: Generic Radio Characteristics

Description	Min	Typ	Max	Unit
Transmit Power BR 1 Mbps, ACR & Modulation Compliant		TBD		dBm
Transmit Power BR 2 Mbps, ACR & Modulation Compliant		TBD		dBm
Transmit Power BR 3 Mbps, ACR & Modulation Compliant		TBD		dBm
Transmit Power LE 1 Mbps, ACR & Modulation Compliant		TBD		dBm
Receiver Sensitivity BR 1 Mbps		TBD		dBm
Receiver Sensitivity EDR 2 Mbps		TBD		dBm
Receiver Sensitivity EDR 3 Mbps		TBD		dBm
Receiver Sensitivity LE 1 Mbps		TBD		dBm
Out-of-band blocking performance 30 MHz~2000 MHz		TBD		dBm
Out-of-band blocking performance 2500 MHz~3000 MHz		TBD		dBm
Out-of-band blocking performance 3000 MHz~12.5 GHz		TBD		dBm

3.4 Electrical Specifications

3.4.1 Absolute Maximum Ratings

Table 3-9: Absolute Maximum Ratings

Parameter		Min	Max	Units
V _{IL}	Input low voltage	-0.3	0.25×V _{IO}	V
V _{IH}	Input high voltage	0.75×V _{IO}	3.3	V
I _{IL}	Input leakage current	-	50	nA
V _{OL}	Output low voltage	-	0.1×V _{IO}	V
V _{OH}	Output high voltage	0.8×V _{IO}	-	V
C _{pad}	Input pin capacitance	-	2	pF
V _{IO}	VDDIO	1.8	3.3	V
I _{MAX}	Maximum drive capability	-	12	mA
T _{STR}	Storage temperature range	-40	150	°C

Table 3-10: Recommended Operating Conditions

Parameter		Min	Typ	Max	Units
V _{BAT}	Battery regulator supply voltage	2.8	3.3	3.6	V
V _{IO}	I/O supply voltage	1.8	3.3	3.3	V
T _{OPR}	Operating temperature range	-40	-	85	°C
V _{IL}	CMOS low level input voltage	0	-	0.3×V _{IO}	V
V _{IH}	CMOS high level input voltage	0.7×V _{IO}	-	V _{IO}	V
V _{TH}	CMOS threshold voltage	-	0.5×V _{IO}	-	V

3.5 Mechanical

3.6 Mechanical Drawings

The AirPrime BX310x module's LGA footprint is a 70-pad array of copper pads (see [Physical Dimensions and Connection Interface on page 9](#)). The following drawings illustrate the device footprint and dimensions.

Note: Dimensions in Figure 3-1 and Figure 3-2 are preliminary and subject to change.

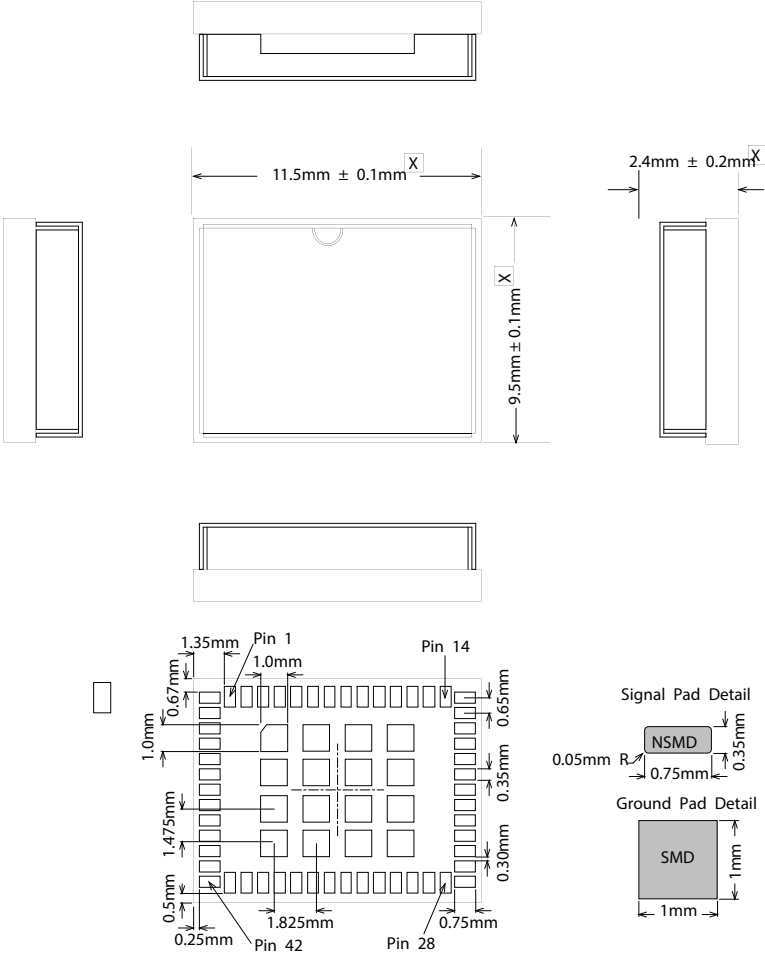

Figure 3-1: AirPrime BX3100 Mechanical Drawing

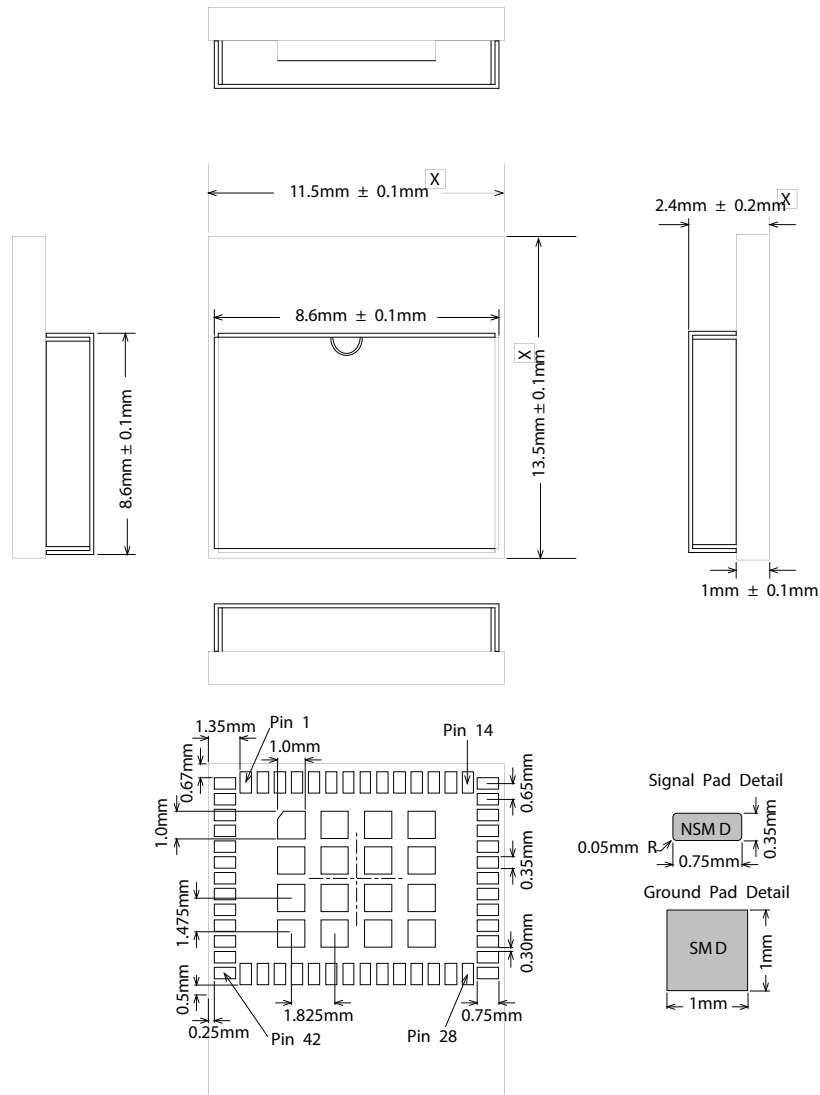

Figure 3-2: AirPrime BX3105 Mechanical Drawing

3.7 Antenna

The AirPrime BX3100 uses an LGA pad (pin 40—RF_MAIN), which the application must connect to an external antenna.

The AirPrime BX3105 includes an integrated PCB antenna. Leave the LGA pad (pin 40) unconnected.

>> 4: Interfaces Specification

4.1 Overview

This section describes the interfaces supported by the AirPrime BX310x embedded module and provides specific voltage, timing, and circuit recommendations for each interface.

4.2 UART

The AirPrime BX310x provides one UART interface for asynchronous communication between the AirPrime BX310x module and a host device (e.g. a PC or host processor):

- UART0—4-wire, RS-232-compliant interface

Note: Up to two additional UART interfaces can be added by configuring GPIOs using AT commands.

Flow control is managed using:

- RTS/CTS signals (This method is required for higher UART interface speeds.)
or
- Software XON/XOFF

[Table 4-1 on page 23](#) describes the signals used for UART0.

Note: UART signals are named with respect to the module, and directions are listed with respect to the module. For example, UART0_RXD is an output from the module to the host.

Table 4-1: UART0 Pins^a

Pin	Interface	Name	Direction	Function	Voltage Level
2	UART0	UART0_RTS	I	Ready To Send, flow control	VDD_PADS_BB
3		UART0_CTS	O	Clear To Send, flow control	
4		UART0_TXD	I	Transmit Data	
5		UART0_RXD	O	Receive Data	

a. If UART0 pins are not used, leave open.

4.3 ADC

The AirPrime BX310x provides two general purpose ADC (Analog to Digital Converter) inputs that are used to measure analog voltages.

Table 4-2: ADC Interface Pins^a

Pin	Signal name	Direction ^b	Function	Voltage Level
18	VDET_1	I	Analog to Digital Converter	VDD_PADS_BB
19	VDET_2	I		

- a. Leave open any pins that are not used.
 b. Signal direction with respect to the module.

4.4 Voltage Measurement

The AirPrime BX310x supports the measurement of analog voltages using the following methods:

- ADCs—Two input pins that can be used for direct voltage measurements. See [ADC on page 24](#).
- Combination of four GPIOs and external capacitors—Small analog signals can be measured by configuring (using AT commands) the pins in [Table 4-3](#) below to support a low-noise programmable gain amplifier with the addition of external 270 pF capacitors between pins 31/32 and pins 34/36. The internal ULP-coprocessor is also designed to measure the voltages while operating in the sleep mode, to enable low power consumption; the CPU can be woken up by a threshold setting and/or via other triggers.

Table 4-3: Voltage-measurement GPIO Pins^a

Pin	Signal Name	Direction ^b	Voltage level
31	SENSOR_VP	I	VDD_PADS_BB
32	SENSOR_CAPP	I	
34	SENSOR_CAPN	I	
36	SENSOR_VN	I	

- a. Leave open any pins that are not used.
 b. Signal direction with respect to the module.

4.5 I²C Interface

The AirPrime BX310x module provides two I²C (Inter-Integrated Circuit) dedicated serial ports (bus interface) based on [8] The I2C Bus Specification, Version 2.1, January 2000 (Phillips Semiconductor document number 9398 393 40011).

The interfaces use the pins indicated in [Table 4-4](#).

Table 4-4: I²C Interface Pins^a

Pin	Signal name	Direction	Function	Voltage Level
9	I2C1_SCL	I/O	Primary I2C interface	VDD_PADS_BB
17	I2C1_SDA	I/O	Primary I2C interface	
53	I2C2_SDA	I/O	Secondary I2C interface	VGPIO
54	I2C2_SCL	I/O	Secondary I2C interface	

a. Leave open any pins that are not used.

This implementation of the I²C interface includes the following characteristics:

- Supported voltage:
 - Primary I2C (1.8 V/3.3 V, configurable)
 - Secondary I2C (3.3 V)
- Standard-mode interface—Data transfer rates up to 100 kbit/s
- Fast-mode interface—Data transfer rates up to 400 kbit/s)
- Master mode operation
- Addressing modes—7-bit; 10-bit; Dual addressing mode

External 2.2 kΩ pull-up resistors must be applied to I²C signals (see [Figure 4-1 on page 25](#)).

For I²C bus details, including I2C bus waveform and timing details, refer to the I2C Bus Specification.

4.5.1 Application

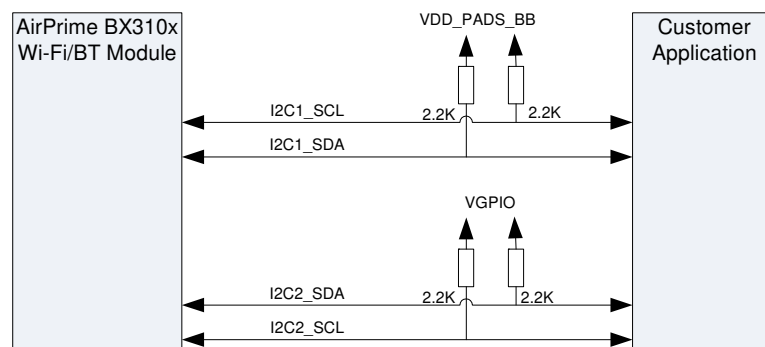

Figure 4-1: Example of I²C Bus Application