



Chipsmall Limited consists of a professional team with an average of over 10 year of expertise in the distribution of electronic components. Based in Hongkong, we have already established firm and mutual-benefit business relationships with customers from,Europe,America and south Asia,supplying obsolete and hard-to-find components to meet their specific needs.

With the principle of “Quality Parts,Customers Priority,Honest Operation,and Considerate Service”,our business mainly focus on the distribution of electronic components. Line cards we deal with include Microchip,ALPS,ROHM,Xilinx,Pulse,ON,Everlight and Freescale. Main products comprise IC,Modules,Potentiometer,IC Socket,Relay,Connector.Our parts cover such applications as commercial,industrial, and automotives areas.

We are looking forward to setting up business relationship with you and hope to provide you with the best service and solution. Let us make a better world for our industry!



## Contact us

Tel: +86-755-8981 8866 Fax: +86-755-8427 6832

Email & Skype: info@chipsmall.com Web: www.chipsmall.com



Address: A1208, Overseas Decoration Building, #122 Zhenhua RD., Futian, Shenzhen, China



# VDSL LINE TRANSFORMER

## For Use With Infineon Chipsets



-  Matched to Infineon VDSL 5000i and 6000i chipset
-  For CO applications over frequency range of 138kHz to 12MHz
-  Designed to meet EN60950 functional insulation requirements

### Electrical Specifications @ 25°C — Operating Temperature -40°C to +85°C

Part Number	Turns Ratio (Pri:Sec)	OCL Primary (mH ±30%)	THD 30kHz, 4Vp-p (dB MIN)	Isolation Voltage (Vrms)
<b>BX4107</b>	1.33:1	8.0	-70	1500

**NOTE:** Transformers are shipped in trays unless Tape & Reel packaging is specified by adding the suffix "T" to the part number (i.e. BX4107T).

### Mechanical

### Schematic

#### BX4107

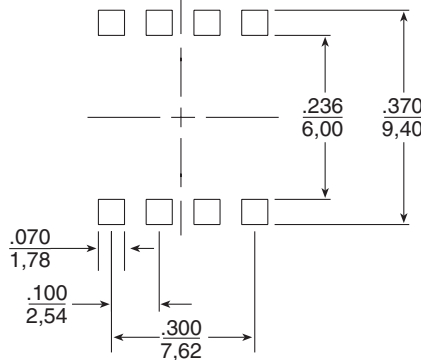
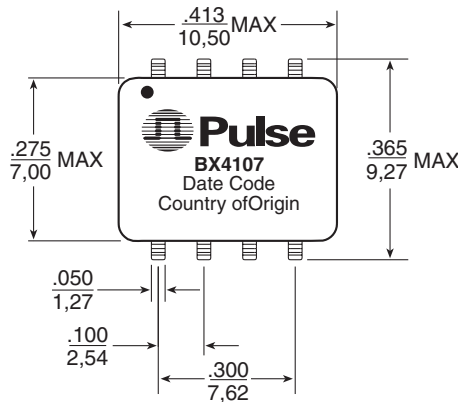

**SUGGESTED PAD LAYOUT**

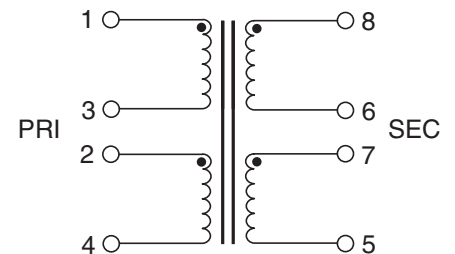

Weight .....1.8 grams  
 Tape & Reel .....300/reel  
 Tray .....95/tray

**Dimensions:**  $\frac{\text{Inches}}{\text{mm}}$   
 Unless otherwise specified,  
 all tolerances are  $\pm \frac{.010}{0.25}$

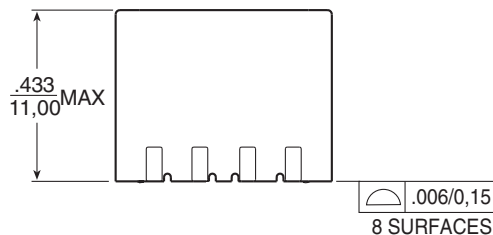

### For More Information:

UNITED STATES (Worldwide)	UNITED KINGDOM (Northern Europe)	FRANCE (Southern Europe)	SINGAPORE (Southern Asia)	TAIWAN, R.O.C. (Northern Asia)	HONG KONG (China/Hong Kong)	DISTRIBUTOR
12220 World Trade Drive San Diego, CA 92128 U.S.A. <a href="http://www.pulseeng.com">http://www.pulseeng.com</a> TEL: 858 674 8100 FAX: 858 674 8262	3 Huxley Road Surrey Research Park Guildford, Surrey GU2 5RE United Kingdom TEL: 44 1483 401700 FAX: 44 1483 401701	Zone Industrielle F-39270 Orgelet France TEL: 33 3 84 35 04 04 FAX: 33 3 84 25 46 41	150 Kampong Ampat #07-01/02 KA Centre Singapore 368324 TEL: 65 6287 8998 FAX: 65 6280 0080	3F-4, No. 81, Sec. 1 HsinTai Wu Road Hsi-Chih, Taipei Hsien Taiwan, R.O.C. Tel: 886 2 2698 0228 FAX: 886 2 2698 0948	Unit 11, 11/F Wah Lai Industrial Centre 10-14 Kwei Tei Street, Fotan, Shatin, Hong Kong TEL: 852 2788 6588 FAX: 852 2776 1055	

Performance warranty of products offered on this data sheet is limited to the parameters specified. Data is subject to change without notice. Other brand and product names mentioned herein may be trademarks or registered trademarks of their respective owners.