



Chipsmall Limited consists of a professional team with an average of over 10 year of expertise in the distribution of electronic components. Based in Hongkong, we have already established firm and mutual-benefit business relationships with customers from,Europe,America and south Asia,supplying obsolete and hard-to-find components to meet their specific needs.

With the principle of “Quality Parts,Customers Priority,Honest Operation,and Considerate Service”,our business mainly focus on the distribution of electronic components. Line cards we deal with include Microchip,ALPS,ROHM,Xilinx,Pulse,ON,Everlight and Freescale. Main products comprise IC,Modules,Potentiometer,IC Socket,Relay,Connector.Our parts cover such applications as commercial,industrial, and automotives areas.

We are looking forward to setting up business relationship with you and hope to provide you with the best service and solution. Let us make a better world for our industry!



Contact us

Tel: +86-755-8981 8866 Fax: +86-755-8427 6832

Email & Skype: info@chipsmall.com Web: www.chipsmall.com

Address: A1208, Overseas Decoration Building, #122 Zhenhua RD., Futian, Shenzhen, China





金龙机电股份有限公司

JINLONG MACHINERY & ELECTRONICS CO., LTD.

www.jinlong-machinery.com

sales@jinlong-machinery.com

PRODUCT SPECIFICATION

客户信息	客户名称/Customer	
	客户代码/Part No.	
	客户确认签章 /Customer Approved Signatures	

K O T L	文件编号/Spec No.	KOTL-S15062	
	品名描述/ Product Description	扁平振动马达 Coin type vibration motor	
	型号/Part No.	C0820B002F	
	送样日期/Date		
	设计/Designed by	审核/Checked by	批准/Approved by
	杨兰/YANG LAN	黄浦/HUANG PU	黄剑辉/HUANG JH
	2015.06.10	2015.06.10	2015.06.10

规格书内容 Contents

1. 重要提示/Importance Notes	3/9
2. 更改记录/Revised Record	3/9
3. 试用范围/Application	4/9
4. 试用条件/Operation condition	4/9
5. 测定条件/Measuring Conditions	4/9
6. 电气性能/Electrical Characteristics	5/9
7. 机械特性/Mechanical Characteristic	5/9
8. 可靠性测试/Reliability Test	6/9
9. 可靠性测试判定标准/Requirement After Reliable Test	6/9
10. 使用注意事项/Cautions for Use	7/9
11. 包装/Packing Require	8/9
12. 外形图/Motor Outline Drawing	9/9

1.重要提示 Importance Notes:

- 1) 如对电机的性能和/或寿命有任何争议，仅基于此规格书作出判断。

If there is any argument on motor performance and/or life, judgment is to be made base on this specification only.

- 2) 客户方有责任确认该电机能满足您的使用要求。

Customer has the responsibility to ensure that the motor can satisfy the requirement of your application.

- 3) 如果贵公司未提供技术规格，该文件将详细叙述与贵公司商定的技术规格。

In the event that an official specification is not present by customer; this document will specify the agreed technical specification .

- 4) 在满足规格的条件下，我司可以改变零件材料、尺寸及形状来改善品质，和/或性能，和/或生产效率。

Within the limitation to satisfy this specification, KOTL has the convenience to change the materials, sizes and shapes of components of the motor for the purpose of improving quality, and/or performance, and/or production efficiency.

- 5) 符合金龙机电股份有限公司最新版《禁用有害物质标准》。

Conform to the Standard of Prohibition in Using Hazardous Substances in new version by Jinlong Machinery & Electronics Co., Ltd

- 6) 收到此规格书后，贵司应于下订单之前将规格书副本签回以示贵司已确认。如贵司未能在规定时间内签回副本，我司将认为贵司已收到并承认该规格书。

After the receipt of this specification, customer should send a signed copy to KOTL before you issued purchase order for the confirmation on acknowledgement. KOTL regard it as the receipt of this specification acknowledged if customer fails to return the confirmation to us within the described period.

2. 更改记录/Revised Record

Rev.	日期/Date	变更点/Reason for change	设计 Designed	审核 Checked	批准 Approval

3. 试用范围/Application

本说明书适用于扁平式永磁直流电机 C0720B 系列.

This specification applies to coin type permanent-magnetic motors DC model C0720B.

4. 试用条件/Operating Condition

项目/Item		标准/Specifications
4-1	额定电压/Rated voltage	3.0V DC
4-2	使用电压/Operating voltage	2.7~3.3V DC
4-3	旋转方向/Rotation	CW (clockwise) or CCW (counter clockwise)
4-4	工作环境/ Operating environment	-20~60℃, 常湿/Ordinary Humidity:65±20%RH
4-5	存储环境/ Storage environment	-30~70℃, 常湿/Ordinary Humidity:65±20%RH

5. 测定条件/Measuring Conditions

项目/Item		标准/Specification
5-1	温度/Temperature	25±3℃
5-2	湿度/Humidity	65±20% RH
5-3	电源电压/Power supply	稳压直流电源/Constant Power supply 3.0V DC.

6. Electrical Characteristics

项目/Item		标准/Specification	条件/Condition
6-1	额定转速/ Rated speed	10000rpm MIN	额定电压下/At rated voltage.
6-2	额定电流/ Rated current	80mA Max	
6-3	启动电/ Starting voltage	2.5V DC Max	/
6-5	绝缘电/ Insulation resistance	10MΩ Min	100V 直流电压下，在线路与壳体间/At DC 100V between wire and case.
6-6	电阻/ Terminal resistance	43 Ω ± 15% (单相/single posture)	At 25°C

7. 机械特性/Mechanical Characteristic

项目/Item		标准/Specification
7-1	测量模具/using dummy set (10g) 设备/equipment: PV-90B 感测器/sensor: VM-83 输入电压: 3.0V input voltage : 3.0V 振动量/Vibrations: 0.8G (AVG.)	<p>马达/Vibration</p> <p>模板/JIG</p> <p>传感器/Sensor</p>
7-2	机械噪音/Mechanical noise	50dB (A) Max.
	在额定电压下/At rated voltage. 背景噪音/Back ground noise 28dB (A) Max.	<p>Microphone</p> <p>Motor</p> <p>Test block</p> <p>Foam</p> <p>100mm</p>

8. 可靠性试验 /Reliability Test

NO.	Item	Test condition	Requirements
8-1	寿命/Life time	额定电压/ Rated voltage: 3.0V DC 试验模式/ Test mode: 2s On, 2s Off, as one cycle. 循环次数/ Test cycle:30000 cycles	在常温常湿下放置 2 小时候后, 马达特性应符合 9-1, 9-2, 98-3 的要求./After 2 hours exposure in ordinary temperature and humidity, Motors shall be approved as specified in item 9-1, 9-2, 9-3.
8-2	低温存储 /Storage in cold	温度/Temperature: -40℃ 时间/Time: 96h	在常温常湿下放置 2 小时候后, 马达特性应符合 9-1, 9-2, 98-3 的要求./After 2 hours exposure in ordinary temperature and humidity, Motors shall be approved as specified in item 9-1, 9-2, 9-3.
8-3	高温存储 /Storage in heat	温度/Temperature: 80℃ 时间/Time: 96h	
8-4	高温高湿 /High Humidity exposure	温度/Temperature: +60℃ 湿度/Humidity: 90%RH 放置时间/ Exposure time: 168h 无水气凝结/ No condensation of moisture	
8-5	振动 /Vibration	全振幅/Displacement: 1.5mm (p-p) 频率/Frequency: 10~55Hz 加速度/Acceleration: 22m/s ² 周期/Period: 10 分钟范围内 (10~55~10Hz)/ 10 Minutes log sweep (10~55~10Hz) 条件/Condition: 在样机中, 在 3 个垂直的轴方向每个方向做 10 分钟的测试。Samples shall be applied for a period of 10 minutes in three axial directions.	在常温常湿下放置 2 小时候后, 马达特性应符合 9-1, 9-2, 98-3 的要求./After 2 hours exposure in ordinary temperature and humidity, Motors shall be approved as specified in item 9-1, 9-2, 9-3.

9. 判定标准/Requirement After Reliable Test

NO.	项目/Item	标准/Specification
9-1	额定转速/Rated speed	初始值的±30% /Initial data±30%
9-2	额定电流/Rated Current	初始值的±30% /Initial data±30%
9-3	启动电压/Starting voltage	≤ 2.5V

10.注意事项/Cautions

10-1 必须按照规格书标准使用，否则性能和寿命都将受到相当地减少，必须注意电压的使用范围。

Unless it is used in accordance with the specifications, the performance and life may be considerably reduced. Due attention should be paid to voltage and range for use.

10-2 建议马达在六个月内使用，不要在以下环境中使用及保存：

1. 高温和高湿的场所；
2. 腐蚀性气体,如：H₂S、SO₂、NO₂、Cl₂；
3. 生锈场所。

Advice uses this motor within 6 months as avoiding as possible. Avoid use or save the motor in the following environment.

1. High temperature and high humidity area
2. Corrosive gas such as H₂S, SO₂, NO₂, Cl₂.
3. Dusty area.

10-3 注意处理马达的工作环境，避免含铁质等物体被马达吸住，否则马达将会产生噪声，性能会降低，从而减少产品可靠性。

Due attention must be paid to the handling and working environments because such objects as iron powder if attracted by the motor magnet, will cause noise, characteristic deterioration thus reducing the reliability.

10-4 应确信本产品不会与相关标准、法律、政令相背。

Please confirm enough no problems of standards and laws and ordinances on your cellular phone.

10-5 拿马达时，要轻拿轻放。

To handle the motor, hold the motor case softly.

10-6 钢板面或边缘有少许锈斑是允许的。

Rust of plate (steel) and similar edge should be OK.

10-7 我司遵循持续发展的策略，在不预先通知的情况下，有对产品（部品）进行修改和改进的权利，当然这些都不会影响马达的特性及使用功能。

Our company follows the sustainable developing strategy, and have the right to make changes and improvements to our product without giving notice in advance. Of course, these changes and improvements will not affect the characteristics and function of the motor.

11. 包装/Packing Require

扁平系列马达包装
Pack drawing of coin type

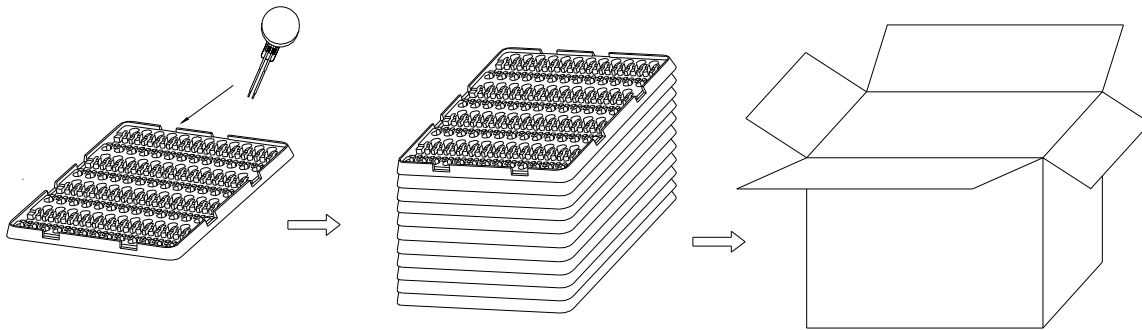

100PCS (1 tray) × 10

1000PCS (1 bundle)

1 box × 2

Remarks:

4000PCS/CTN: 45cm × 28cm × 20cm

6000PCS/CTN: 45cm × 28cm × 30cm

包装试验要求:

沿外包装箱±x, ±y和±z方向, 距水泥地面1.5m高度, 各自由跌落2次, 马达应无机械损伤, 电气性能仍符合标准要求。

Drop Test with carton:

Drop the carton in the axial directions of ±x, ±y, ±z onto the concrete floor from 1.5m height, drop twice each direction. After drop test, no mechanical damage to motors, and the electrical performances remain unchanged.

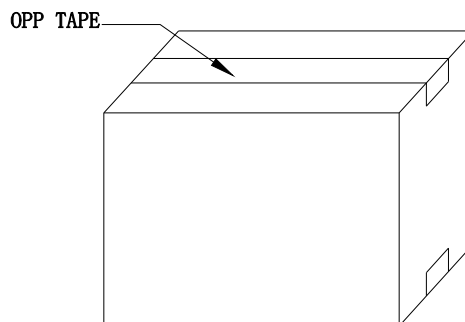

12. 外形图/Motor Outline Drawing

金龙标志

零件登记

旧底图总号

底图总号

签字

日期

档案员 日期

www.jinlong-machinery.com

尺寸: $\phi 7 \pm 0.05$, 2.1 ± 0.05 , 4.7 ± 0.1 , 5

生产代号: ["1"表示"生产一线", 以此类推]

印字/	A	B	D	E	F	I	J	R	S	T	Q	K				
数字/	1	2	3	4	5	6	7	8	9	10	11	12	13	14	15	16
字母/	J	K	L	M	N	P	Q	R	S	T	U	V	W			
日期	17	18	19	20	21	22	23	24	25	26	27	28	29	30		

马达型号

型号/	1234	1227	1034	1030	1027	0834	1020	0830	0827	0825	1030	0720
规格/												2V

生产年月: 月: [1-9月份用该月数字, 10月用"A"表示, 11月用"B"表示, 12月用"C"表示]
 年: [取末位数字(例如3表示2013年, 以此类推)]

标记	处数	更改文件号	签字	日期	图样标记	版次	比例
设计							
制图					S	S1	1:1
校对							
工艺							

<p>金龙机电股份有限公司</p> <p>www.jinlong-machinery.com</p> <p>材质:</p>	<p>外形图</p> <p>03.03.C0720</p>
共 张	第 张