



Chipsmall Limited consists of a professional team with an average of over 10 year of expertise in the distribution of electronic components. Based in Hongkong, we have already established firm and mutual-benefit business relationships with customers from,Europe,America and south Asia,supplying obsolete and hard-to-find components to meet their specific needs.

With the principle of “Quality Parts,Customers Priority,Honest Operation,and Considerate Service”,our business mainly focus on the distribution of electronic components. Line cards we deal with include Microchip,ALPS,ROHM,Xilinx,Pulse,ON,Everlight and Freescale. Main products comprise IC,Modules,Potentiometer,IC Socket,Relay,Connector.Our parts cover such applications as commercial,industrial, and automotives areas.

We are looking forward to setting up business relationship with you and hope to provide you with the best service and solution. Let us make a better world for our industry!



Contact us

Tel: +86-755-8981 8866 Fax: +86-755-8427 6832

Email & Skype: info@chipsmall.com Web: www.chipsmall.com

Address: A1208, Overseas Decoration Building, #122 Zhenhua RD., Futian, Shenzhen, China



Type C1Q

Surface Mount Very Fast-Acting Chip Fuse

HF **Pb** C1Q Series - 1206 Size

RoHS 6 Compliant

Features

- Fast Acting
- Small size, 1206 SMD
- Current rating from 250mA to 7A
- Wide operating temperature range from -55 °C to 125 °C
- Tape & Reel for automatic SMD placement
- Compatible with 260°C IR Pb-free and wave soldering process
- RoHS 6 compliant (MSL = 1)
- Halogen Free
- Leadfree

Applications

- Notebook
- LCD monitor
- PC computer
- Office electronic equipment
- Industrial equipment
- Medical equipment
- POE, POE+
- LCD / LED monitor
- Power supply
- LCD / LED TV
- DC-DC Converter

LEAD FREE = **Pb**
 HALOGEN FREE = **HF**



Electrical Characteristics (UL/CSA/STD. 248-14)

Testing Current	Blow Time	
	Minimum	Maximum
100%	4 Hrs.	N/A
200%	N/A	5 Sec
300%	N/A	0.2 Sec

Safety Agency Approvals

SAFETY AGENCY	SAFETY AGENCY CERTIFICATE	VOLTAGE RATING (V)	AMPERE RANGE / VOLT @ I.R. ABILITY*
SP	LR39772	250mA - 5A / 125V AC 63V DC 7A / 63V AC & DC	250mA - 5A / 125V AC @ 100A 63V DC @ 50A 7A / 63V AC & DC @ 50A
UL	E20624		
RU	E20624		

* I.R. = INTERRUPTING RATING = SHORT CIRCUIT RATING (AMPS)

Physical Specifications

Materials	Body : Ceramic Substrate
	Terminations : Ag / Ni / Sn (100% Lead-free)
	Element Cover Coating : Lead-free Glass
Marking	On Fuse :
	None
	On Label :
	"bel", "C1Q", "Current Rating", "Voltage Rating", "Interrupting Rating", "Appropriate Safety Logos" and "♻️", "♻️" (China RoHS compliant).

Specifications subject to change without notice



Bel Fuse Inc. +1 201.432.0463
 206 Van Vorst Street Bel.US.CS@belf.com
 Jersey City, NJ 07302 USA belfuse.com/circuit-protection

Type C1Q

Surface Mount Very Fast-Acting Chip Fuse

HF Pb C1Q Series - 1206 Size

RoHS 6 Compliant

Average Time Current Curve

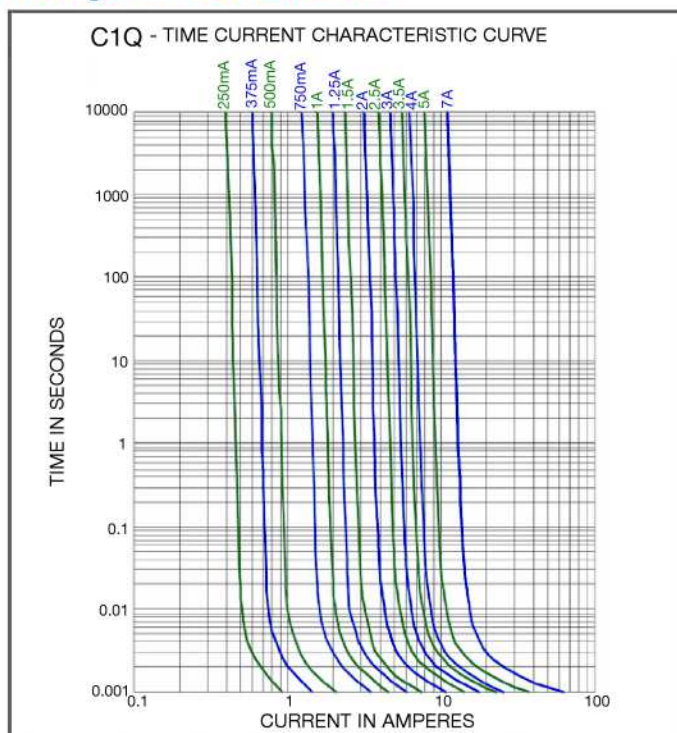

Temperature Derating Curve

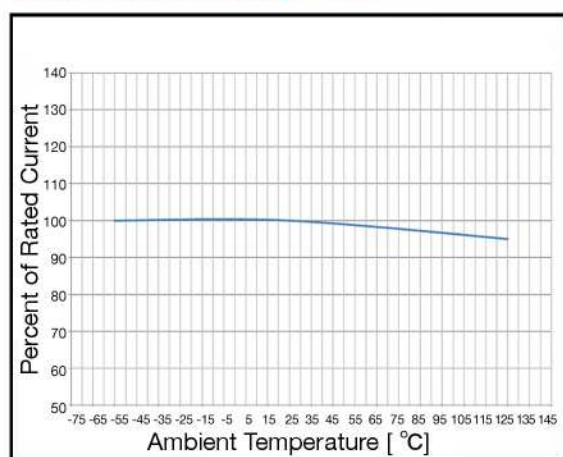

Electrical Specifications

Catalog Number	Ampere Rating (A)	Nominal Cold Resistance (ohm)	Nominal Volt-drop @100% In (Volt)	Voltage and Interrupting Ratings	Melting I ² T @10 In (A ² Sec)	Nominal Power Dissipation @100% In (W)	Agency Approvals		
							UL	CSA	SP
C1Q 250	250mA	0.85	0.250	See Table of Safety Approvals on Page 1 for Voltage and associated Interrupting Ratings	0.00003	0.06	Y		Y
C1Q 375	375mA	0.48	0.222		0.00006	0.08	Y		Y
C1Q 500	500mA	0.32	0.195		0.00011	0.10	Y		Y
C1Q 750	750mA	0.175	0.163		0.00042	0.12	Y		Y
C1Q 1	1A	0.124	0.156		0.00096	0.16	Y		Y
C1Q 1.25	1.25A	0.092	0.149		0.0020	0.19	Y		Y
C1Q 1.5	1.5A	0.075	0.142		0.0024	0.21	Y		Y
C1Q 2	2A	0.054	0.140		0.005	0.28	Y		Y
C1Q 2.5	2.5A	0.042	0.138		0.008	0.35	Y		Y
C1Q 3	3A	0.035	0.136		0.020	0.41	Y		Y
C1Q 3.5	3.5A	0.030	0.140		0.029	0.49	Y		Y
C1Q 4	4A	0.028	0.144		0.038	0.58	Y		Y
C1Q 5	5A	0.022	0.154		0.075	0.77	Y		Y
C1Q 7	7A	0.015	0.160		0.116	1.12		Y	

Consult manufacturer for other ratings

Specifications subject to change without notice



Bel Fuse Inc.
206 Van Vorst Street
Jersey City, NJ 07302 USA

+1 201.432.0463
Bel.US.CS@belf.com
belfuse.com/circuit-protection

Type C1Q

Surface Mount Very Fast-Acting Chip Fuse

HF Pb C1Q Series - 1206 Size

RoHS 6 Compliant

Environmental Specifications

Shock Resistance	MIL-STD-202G, Method 213B, Test Condition 1 (100 G's peak for 6 milliseconds; Sawtooth waveform)
Vibration Resistance	MIL-STD-202G, Method 201A(10-55 Hz,0.06 inch, total excursion).
Salt Spray Resistance	MIL-STD-202G, Method 101E, Test Condition B(48 hrs).
Insulation Resistance	MIL-STD-202G, Method 302, Test Condition A (After Opening) 10,000 ohms minimum.
Solderability	MIL-STD-202G, Method 208H
Resistance to solder Heat	MIL-STD-202G, Method 210F, Test Condition C. Top Side(260 °C, 20 sec) MIL-STD-202G, Method 210F, Test Condition D.Bottom Side(260 °C,10 sec)
Thermal Shock	MIL-STD-202G, Method 107G, Test Condition B (-65 °C to +125 °C).
Operating Temperature	-55 °C to +125 °C
Moisture Sensitivity Level	1 (According to IPC J-Std-020)

Soldering Parameters

IR Reflow Profile (IPC/JEDEC J-STD-020D)	
Preheat & Soak	
Temperature min (T_{smin})	150 °C
Temperature max (T_{smax})	200 °C
Time (T_{smin} to T_{smax}) (t_s)	60 -120 seconds
Average ramp-up rate (T_{smax} to T_p)	3 °C/second max.
Liquidous temperature (T_L)	217 °C
Time at liquidous (t_L)	60 - 150 seconds
Peak temperature (T_p)	260 °C max
Time (t_p) within 5 °C of the specified classification temperature (T_c)	30 seconds
Average ramp-down rate (T_p to T_{smax})	6 °C/second max.
Time 25 °C to peak temperature	8 minutes max.

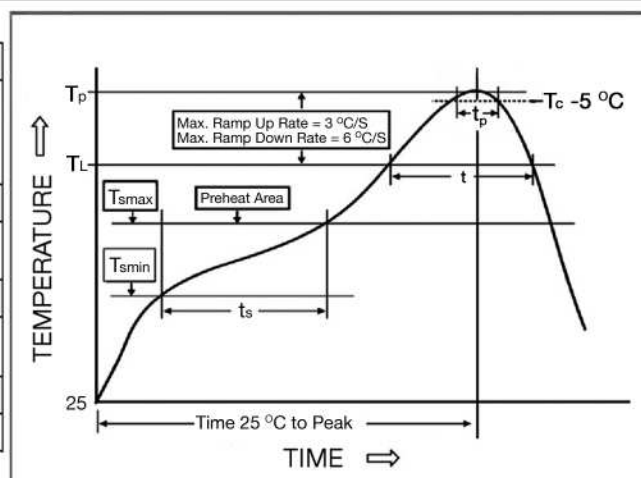

Lead-free Wave Soldering Profile	
Wave Soldering Parameter	
Average ramp-up rate	200 °C / second
Heating rate during preheat	typical 1 - 2 °C / second Max 4 °C / second
Final preheat temperature	within 125 °C of soldering temperature
Peak temperature T_p	260 °C
Time within +0 °C / -5 °C of actual peak temperature	10 seconds
Ramp-down rate	5 °C / second max.

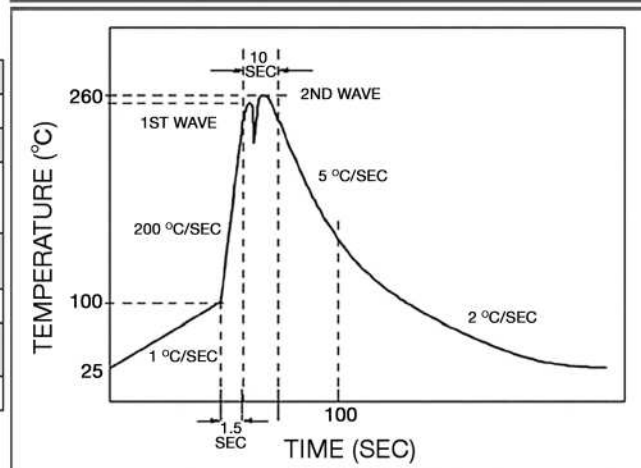

Specifications subject to change without notice



Bel Fuse Inc. +1 201.432.0463
206 Van Vorst Street Bel.US.CS@belf.com
Jersey City, NJ 07302 USA belfuse.com/circuit-protection

Type C1Q

Surface Mount Very Fast-Acting Chip Fuse

HF **Pb** C1Q Series - 1206 Size

RoHS 6 Compliant

Fuse FGNO Explanation

0685 - [XXXX] - XX

[XXXX]=Ampere Rating; XX=See Ordering Information as below

Fraction	Decimal	Milliamps	Bel FGNO[XXXX]	Fraction	Decimal	Amps	Bel FGNO[XXXX]
1/4	0.250	250	0250		1.0	1	1000
3/8	.375	375	0375	1-1/4	1.25	1.25	1250
1/2	.500	500	0500	1-1/2	1.50	1.5	1500
3/4	.750	750	0750		2.0	2	2000
				2-1/2	2.5	2.5	2500
					3.0	3	3000
				3-1/2	3.5	3.5	3500
					4.0	4	4000
					5.0	5	5000
					7.0	7	7000

Mechanical Dimensions

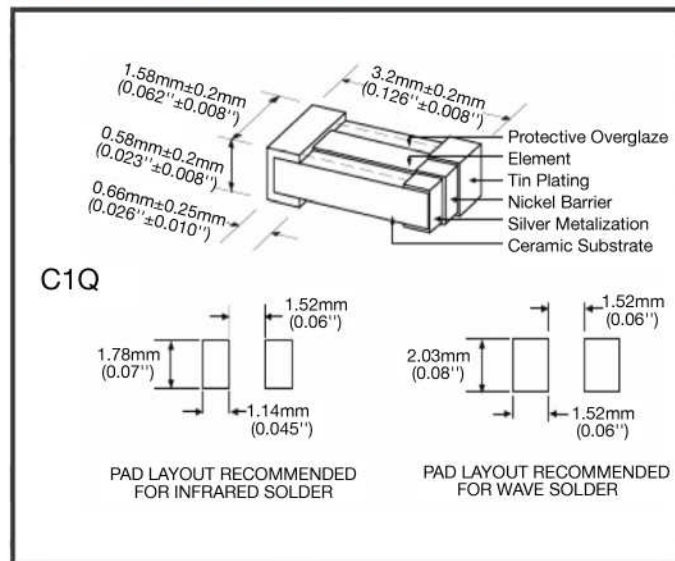

Ordering Information

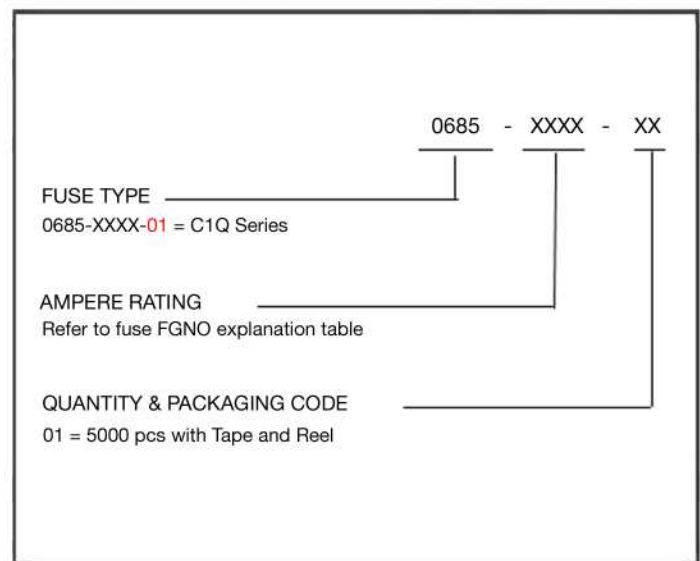

Packaging

Packaging Tape & Reel	Packaging Specification	Quantity	Quantity & Packaging Code
8 mm wide tape with 7 inches Diameter reel	EIA Standard 481-E	5000	0685-XXXX-01

Specifications subject to change without notice



Bel Fuse Inc.
206 Van Vorst Street
Jersey City, NJ 07302 USA

+1 201.432.0463
Bel.US.CS@belf.com
belfuse.com/circuit-protection