



Chipsmall Limited consists of a professional team with an average of over 10 year of expertise in the distribution of electronic components. Based in Hongkong, we have already established firm and mutual-benefit business relationships with customers from,Europe,America and south Asia,supplying obsolete and hard-to-find components to meet their specific needs.

With the principle of “Quality Parts,Customers Priority,Honest Operation,and Considerate Service”,our business mainly focus on the distribution of electronic components. Line cards we deal with include Microchip,ALPS,ROHM,Xilinx,Pulse,ON,Everlight and Freescale. Main products comprise IC,Modules,Potentiometer,IC Socket,Relay,Connector.Our parts cover such applications as commercial,industrial, and automotives areas.

We are looking forward to setting up business relationship with you and hope to provide you with the best service and solution. Let us make a better world for our industry!



Contact us

Tel: +86-755-8981 8866 Fax: +86-755-8427 6832

Email & Skype: info@chipsmall.com Web: www.chipsmall.com

Address: A1208, Overseas Decoration Building, #122 Zhenhua RD., Futian, Shenzhen, China



THIS COPY IS PROVIDED ON A RESTRICTED BASIS AND IS NOT TO BE USED IN ANY WAY DETRIMENTAL TO THE INTERESTS OF PANDUIT CORP.

NOTES:

1. DIMENSIONS IN [] ARE IN MILLIMETERS.



PANDUIT PART NO.	MATERIAL	FACE COLOR	PKG. QTY.	THICKNESS	PRODUCT TYPE
C200X100A0T	GMH3	BLACK	500	.030 +/- .010	POLYESTER/ FOAM COMPONENT LABEL
C200X100A8T		YELLOW			
C200X100AMT		SILVER			
C200X100APT	GMH3-W	WHITE			
C200X100AST	GMH3	GREEN			
C200X100AUT		ORANGE			
C200X100AWT		RED			

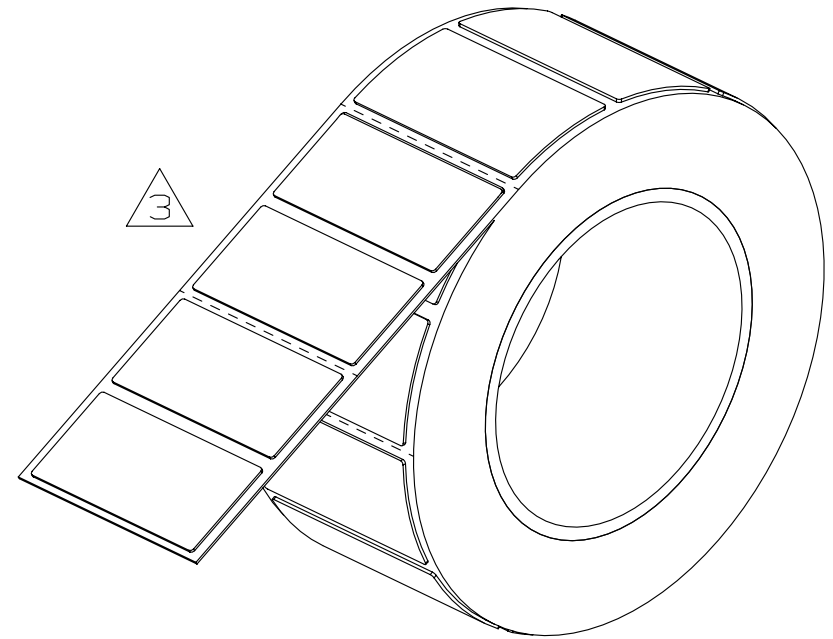
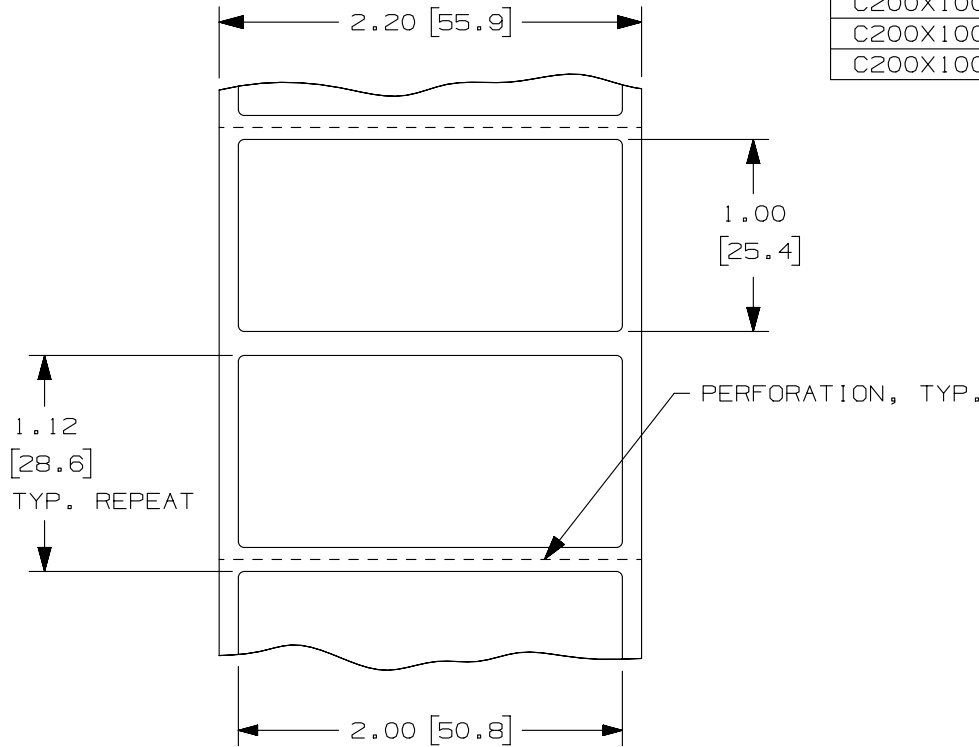

REV	DATE	BY	CHK	APR	DESCRIPTION	ECN
3	1/11/13	RVU	DAPE	SEWH	ADD material column and ISO view. Update part numbers sequence list.	GAECN00536
2	5/8/11	RVU	DAPE		TOL. SHOULD BE .12, .062, NOT .1, .050. ADD NEW PN: C200X100AUT.	6348
1	1/14/09	RVU	DAPE		ADDED "TYP. REPEAT".	5592
0	9/5/08	RVU	DAPE	PTR	DRAWING RELEASE.	5537

TITLE		RAISED PANEL PUSH BUTTON LABELS C200X100A*T		
ITEM REVISION NAME		CUSTOMER DRAWING		
DATASET FILE NAME		100491BQ/05		
MATERIAL:		SEE TABLE		
DRAWING NUMBER:		C10730		
DRAWN BY	DATE	CHK	SCALE	SIZE
RVU	9/5/08	SCWE	NTS	A

D10100DA/12